

(1) PCI-EXPRESS EDGE CONNECTOR

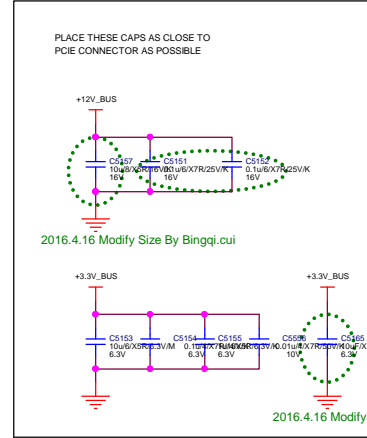
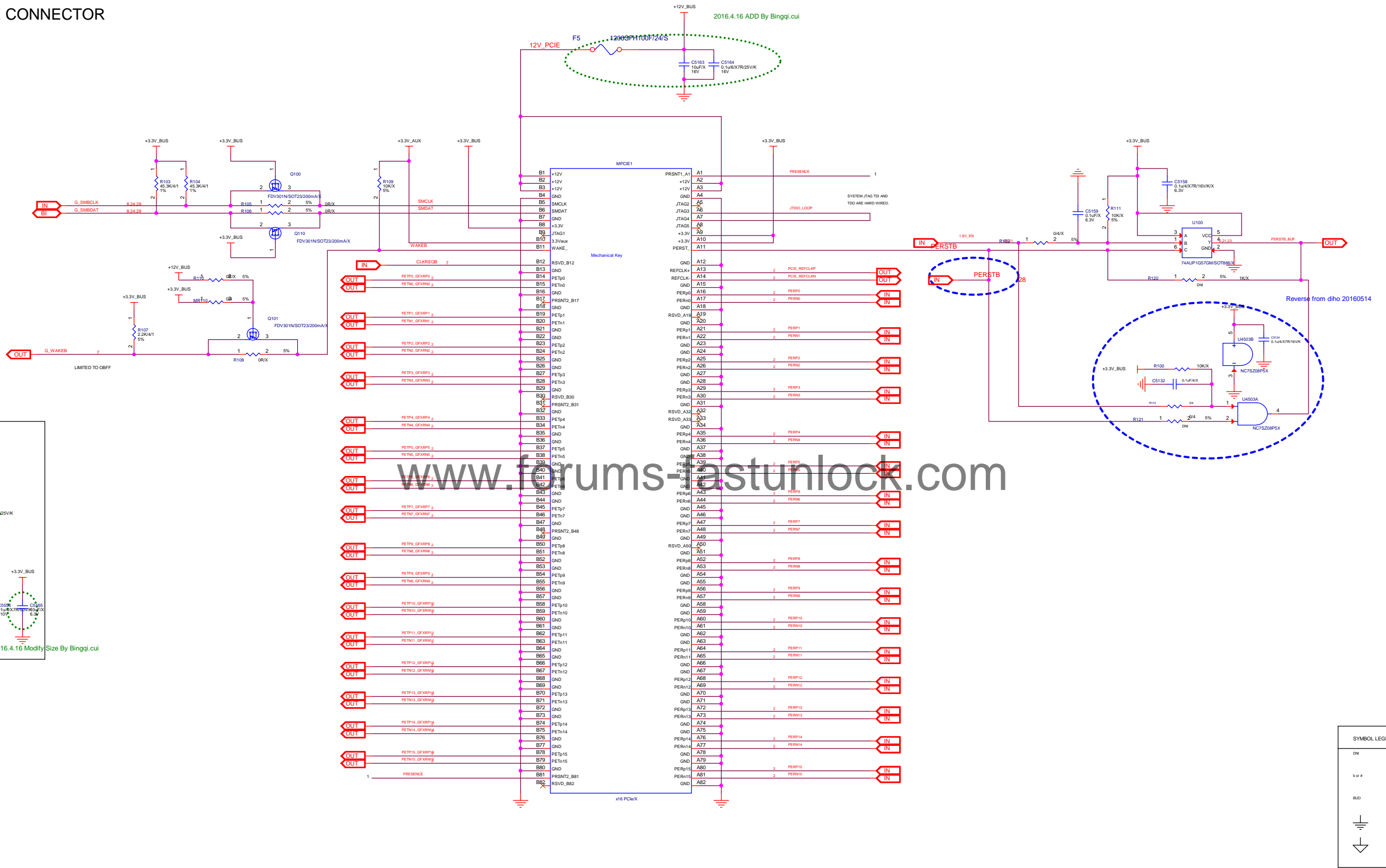

www.forums-tastinlock.com

GIGABYTE		
Title PCI Express		
Size Custom	Document Number GV-RX570GAMING-8GD-MI	Rev 1.11
Date Friday, June 01, 2018	Sheet 1	of 29

(2) ELLESMERE PCIE INTERFACE

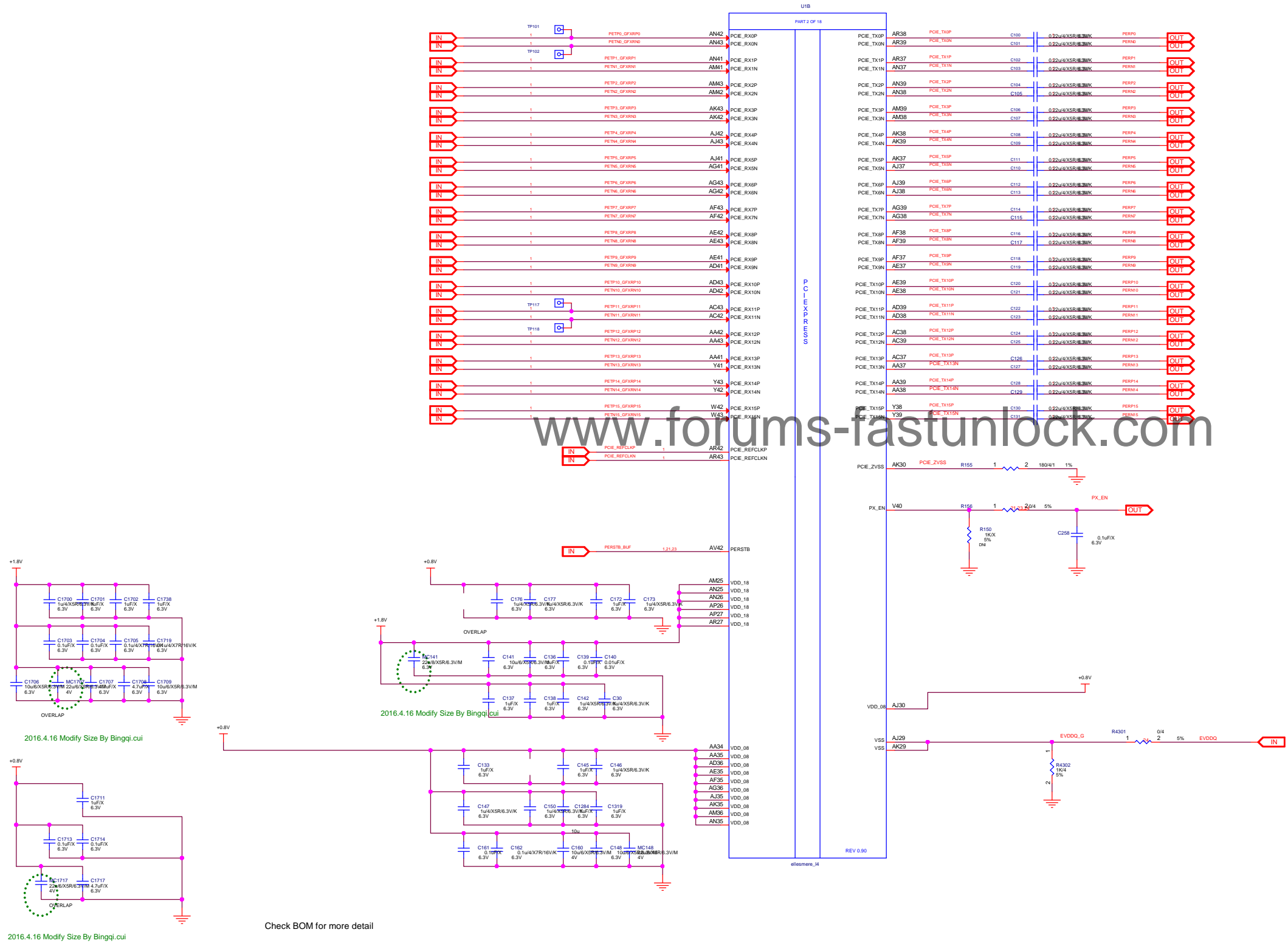

Check BOM for more detail

GIGABYTE			
Title ELLESMERE PCIE INTERFACE			
Size	Document Number	Rev	
Custom	GV-RX570GAMING-8GD-MI	1.11	
Date:	Friday, June 01, 2018	Sheet	2 of 29

(3) ELLESMERE MEM INTERFACE CH A/B

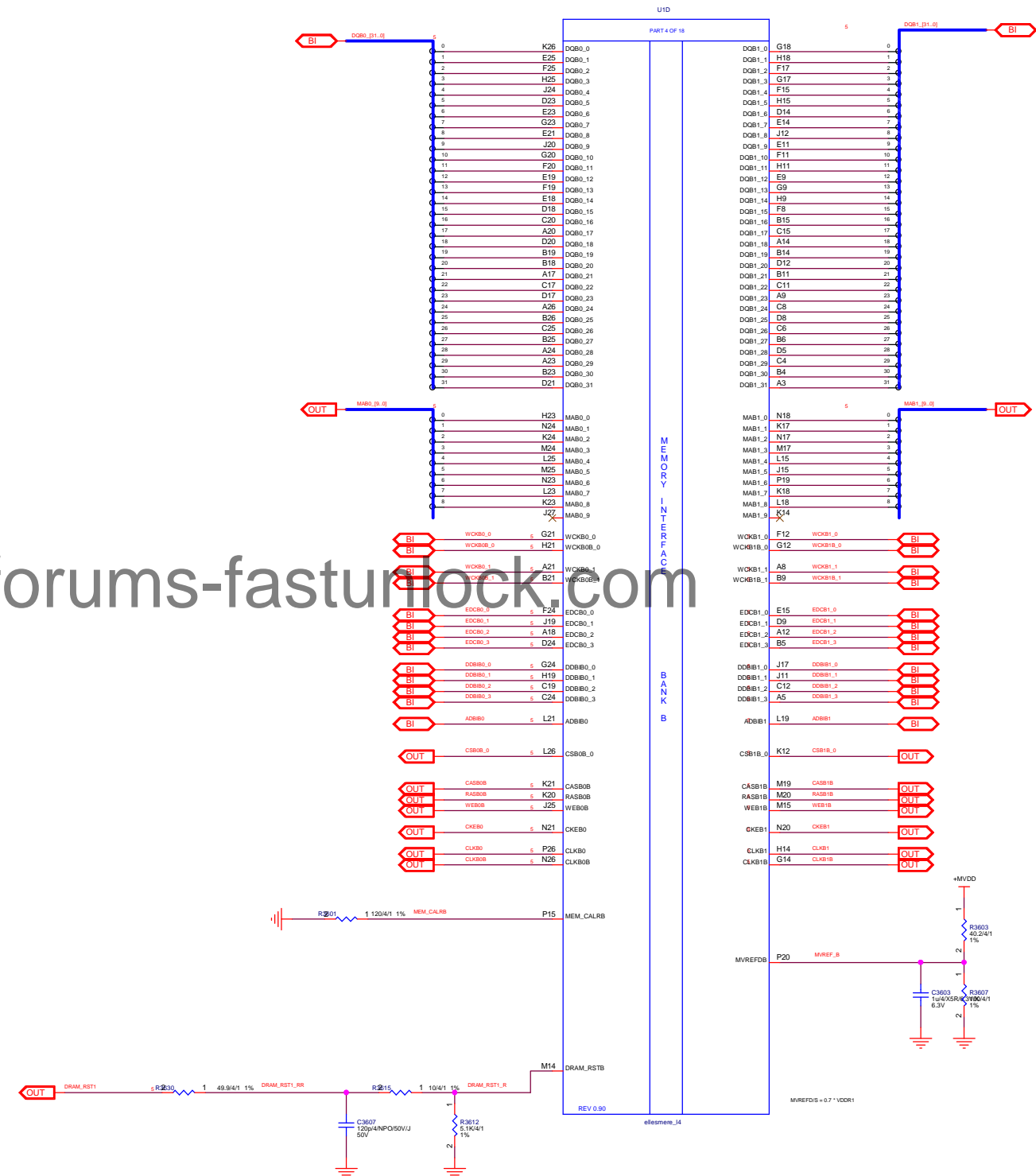
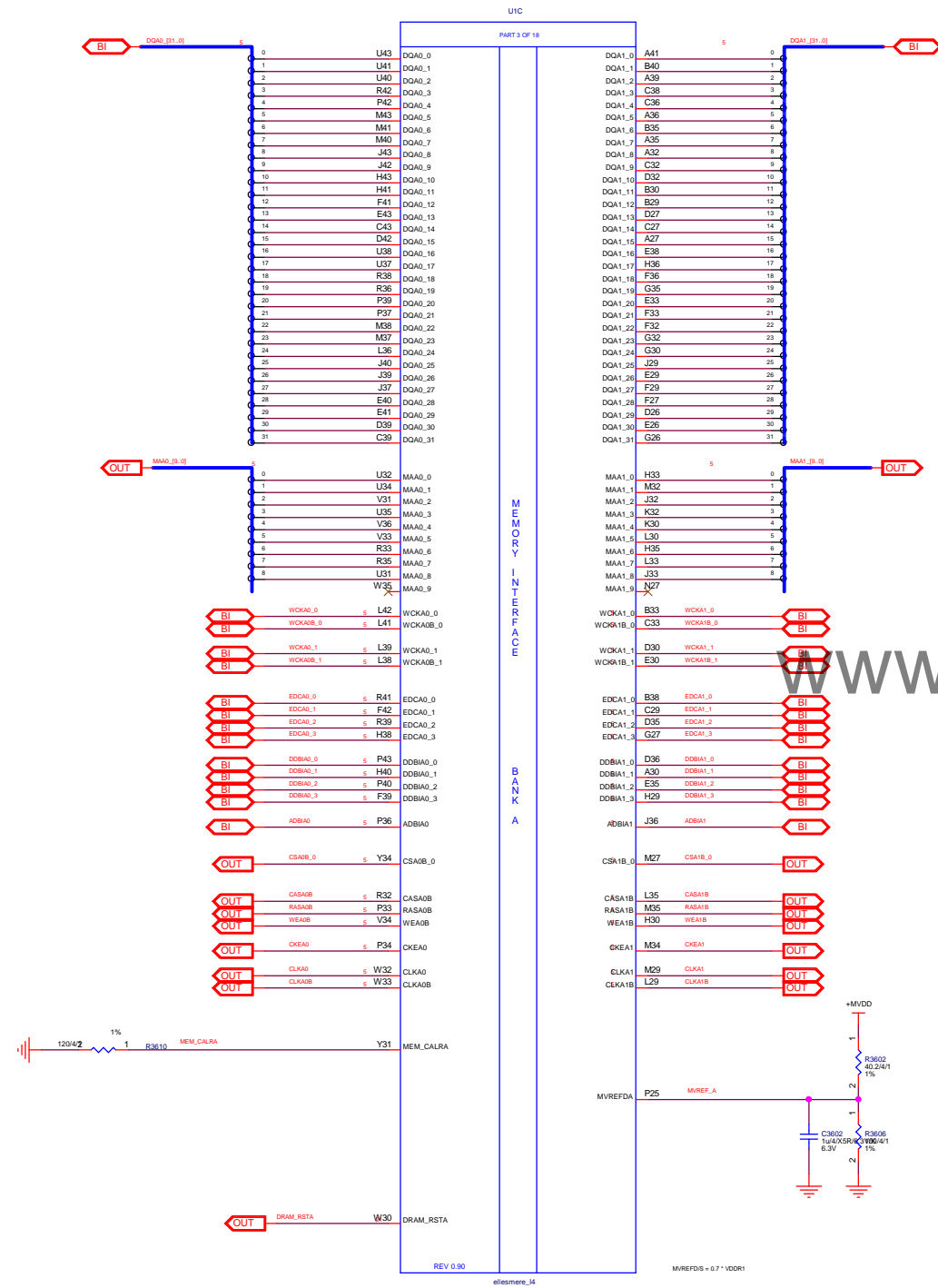

(4) ELLESMERE MEM INTERFACE CH C/D

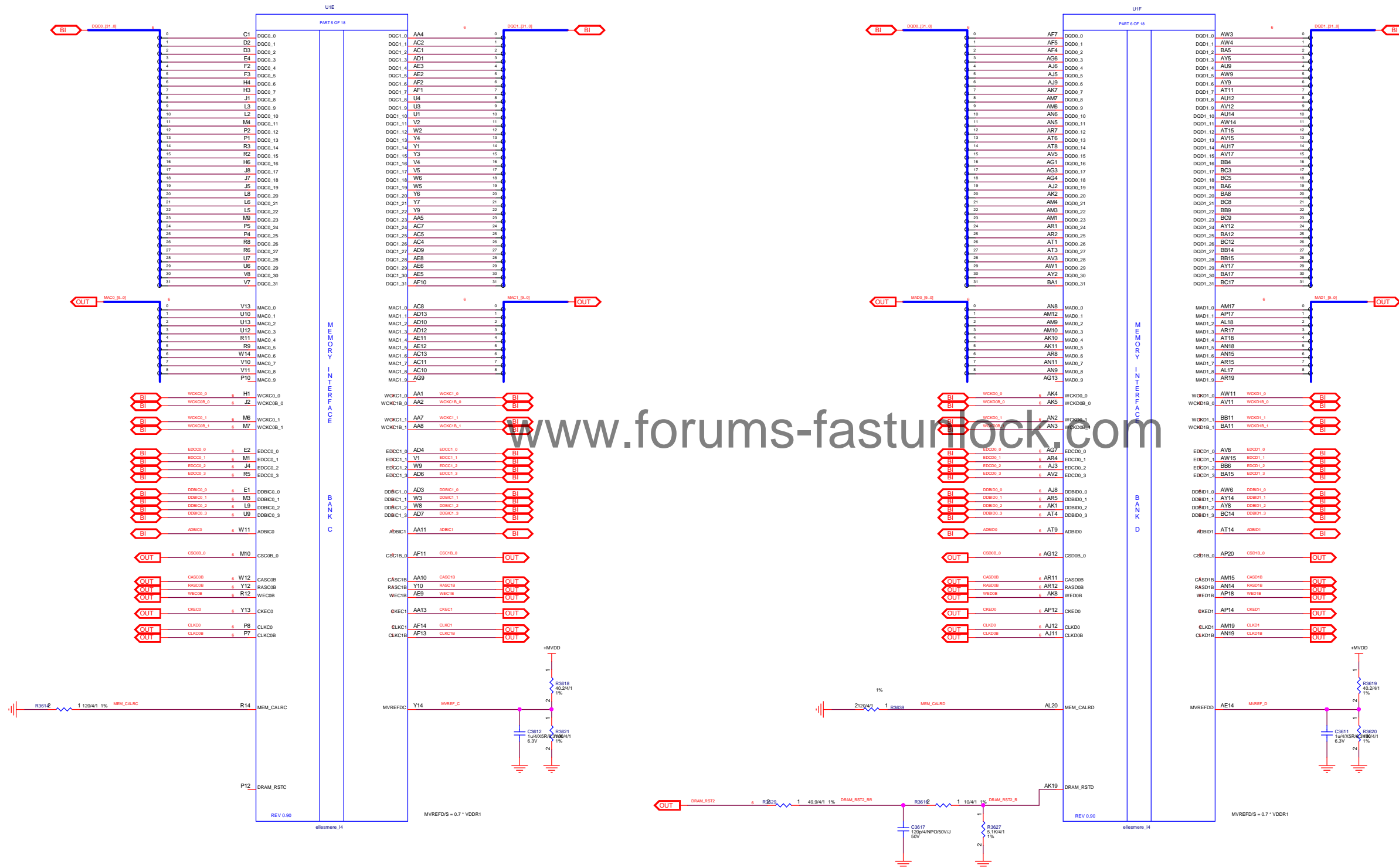

(5) GDDR5 MEMORY CH A/B

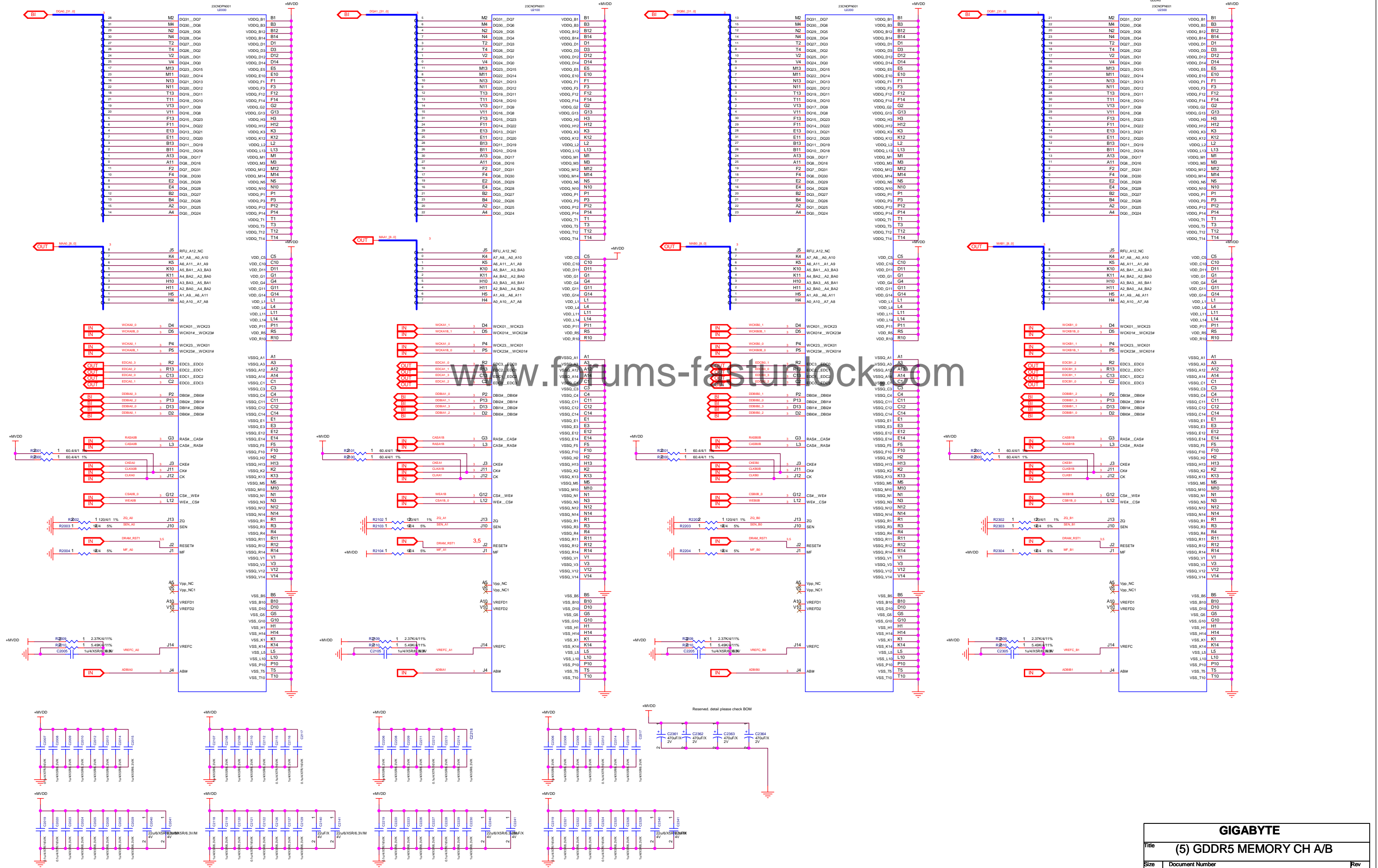

(7) ELLESMERE GPIO STRAP CF XTAL

SCLSDA BUS:		
IC ADDRESS	FUNCTION	DEVICE

DDCVGA BUS:		
IC ADDRESS	FUNCTION	DEVICE
048	EXT TEMP SENSOR	LM9603

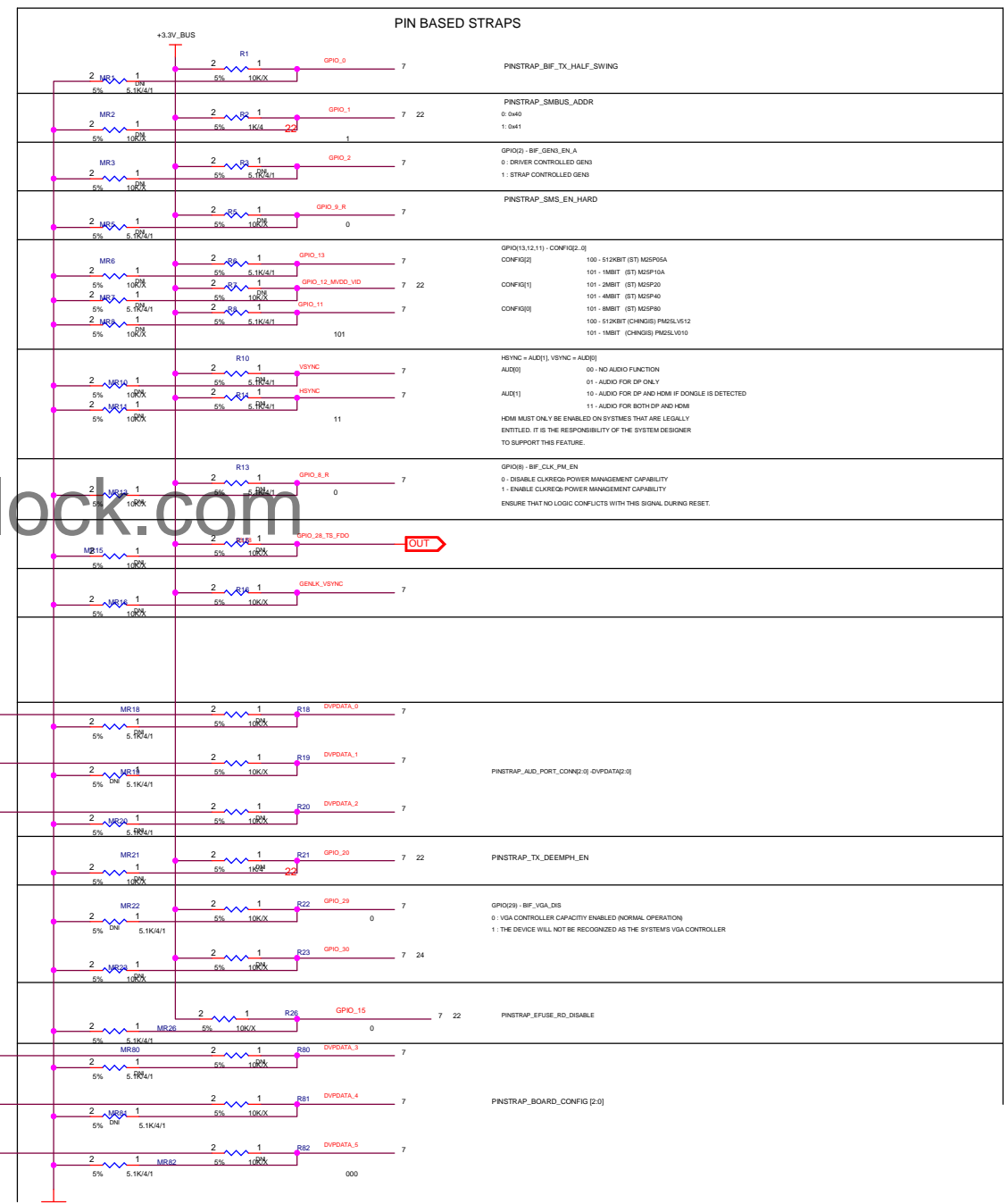
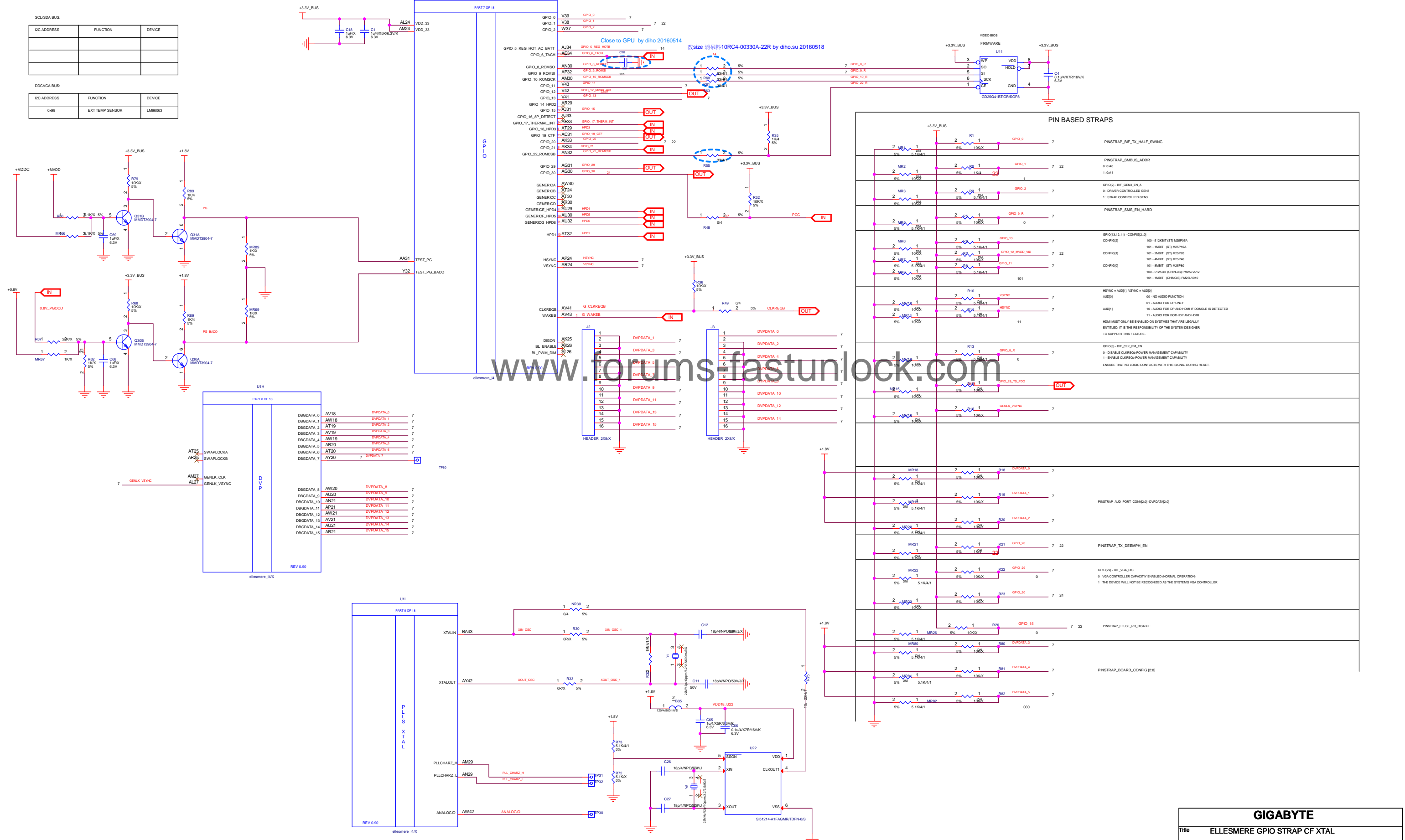

GIGABYTE			
Title ELLESMERE GPIO STRAP CF XTAL			
Size	Document Number	Rev	
Custom	GV-RX570GAMING-8GD-MI	1.11	
Date:	Friday, June 01, 2018	Sheet	7 of 29

(8) ELLESMERE DAC1 LOCK

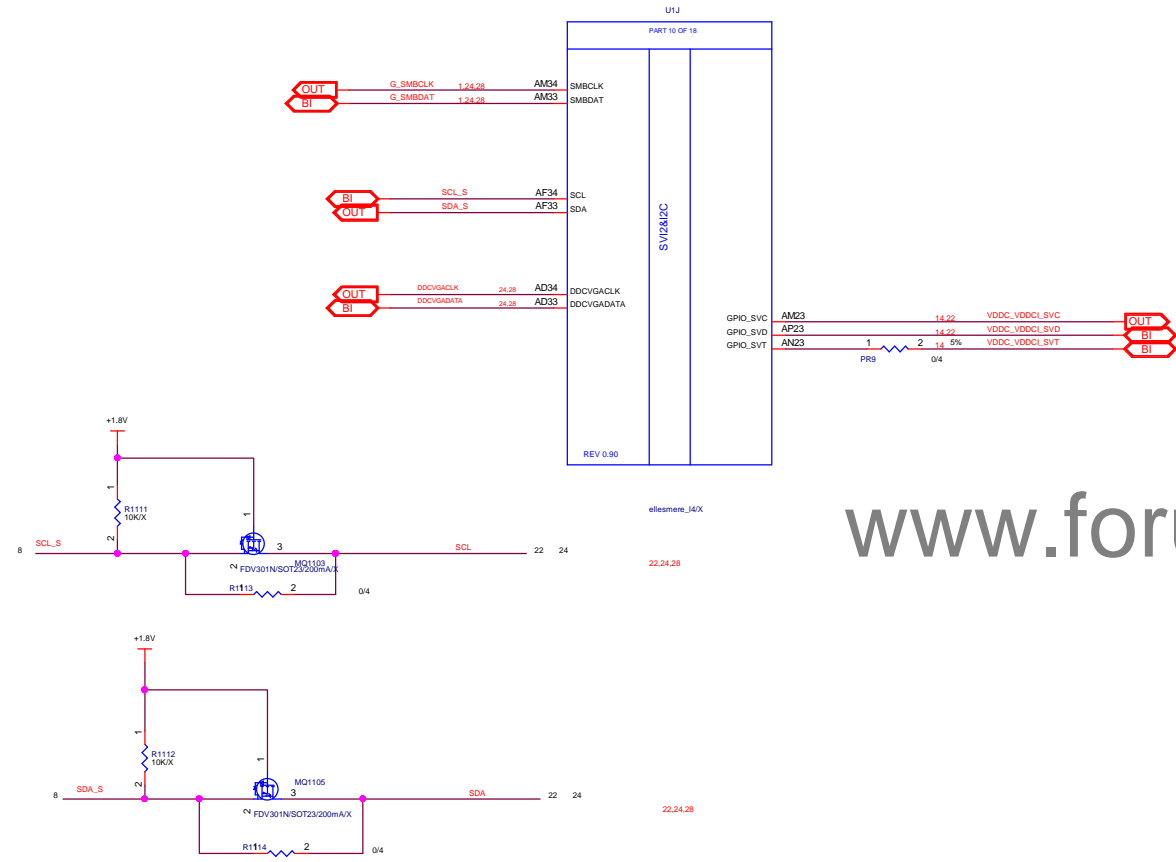

GIGABYTE		
Title ELLESMERE DAC1 LOCK		
Size	Document Number	Rev
Customer	GV-RX570GAMING-8GD-MI	1.11
Date:	Friday, June 01, 2018	Sheet 8 of 29

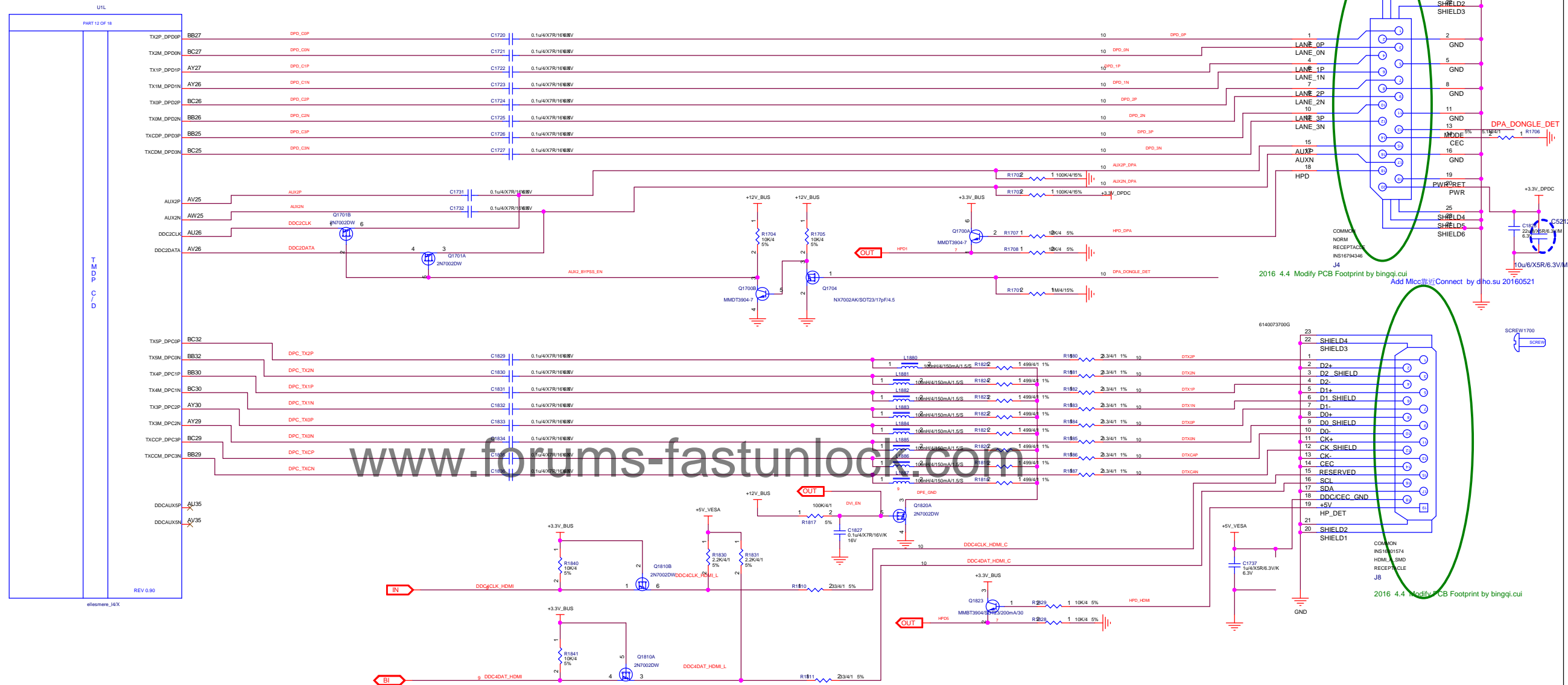

www.forums-fastunlock.com

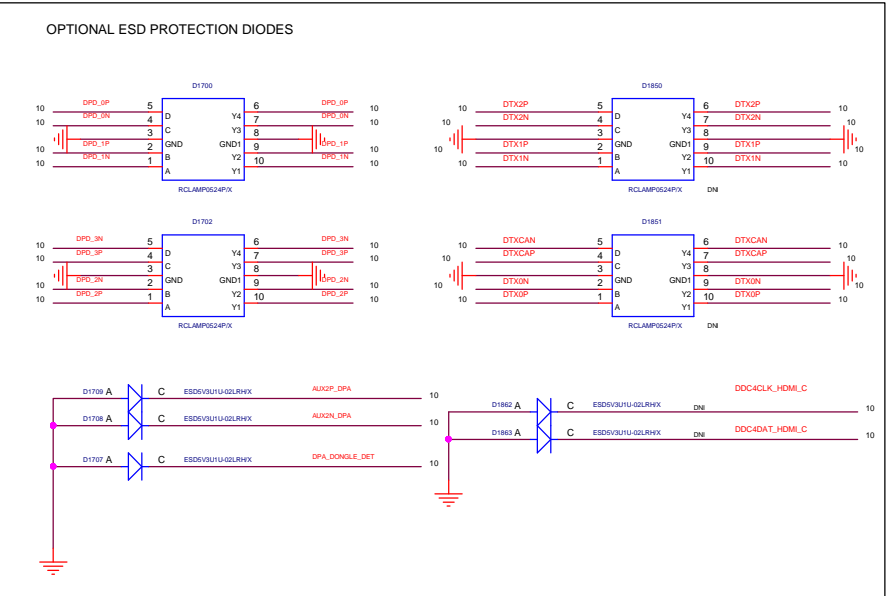

GIGABYTE		
Title ELLESMERE TMDP C/D		
Size Custom	Document Number GV-RX570GAMING-8GD-MI	Rev 1.11
Date: Friday, June 01, 2018	Sheet 10 of 29	

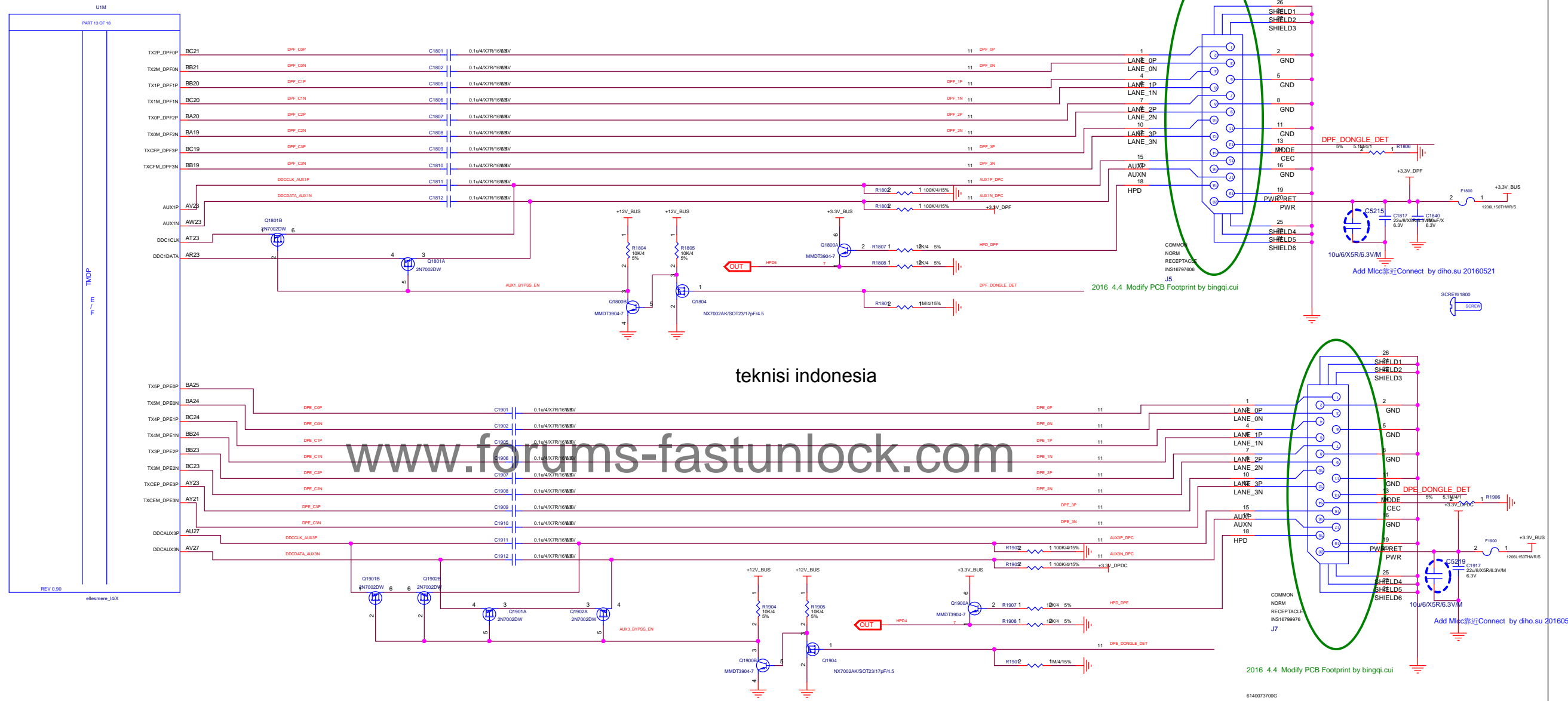

teknisi indonesia

www.forums-fastunlock.com

OPTIONAL ESD PROTECTION DIODES

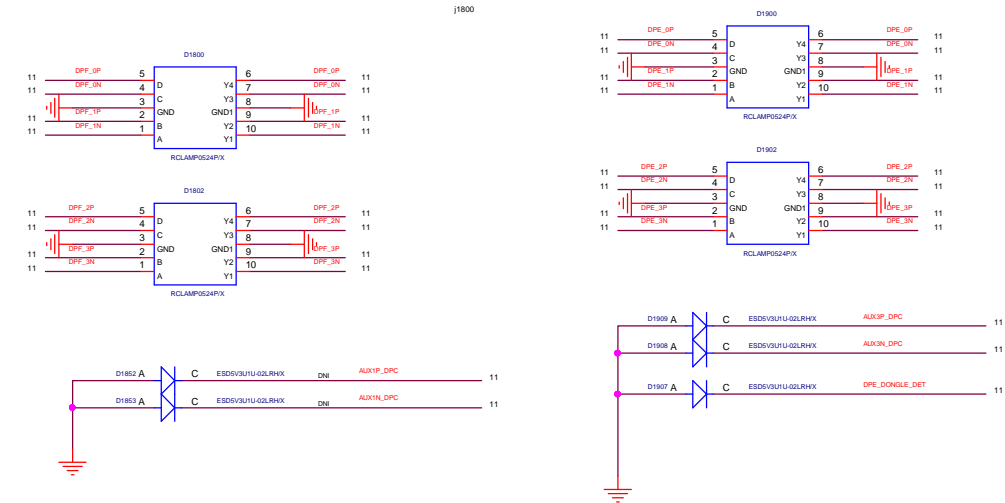

GIGABYTE			
Title ELLESMERE LVTMDP E/F			
Size	Document Number	Rev	
Custom	GV-RX570GAMING-8GD-MI	1.11	
Date:	Friday, June 01, 2018	Sheet	11 of 29

(12) ELLESMERE POWER

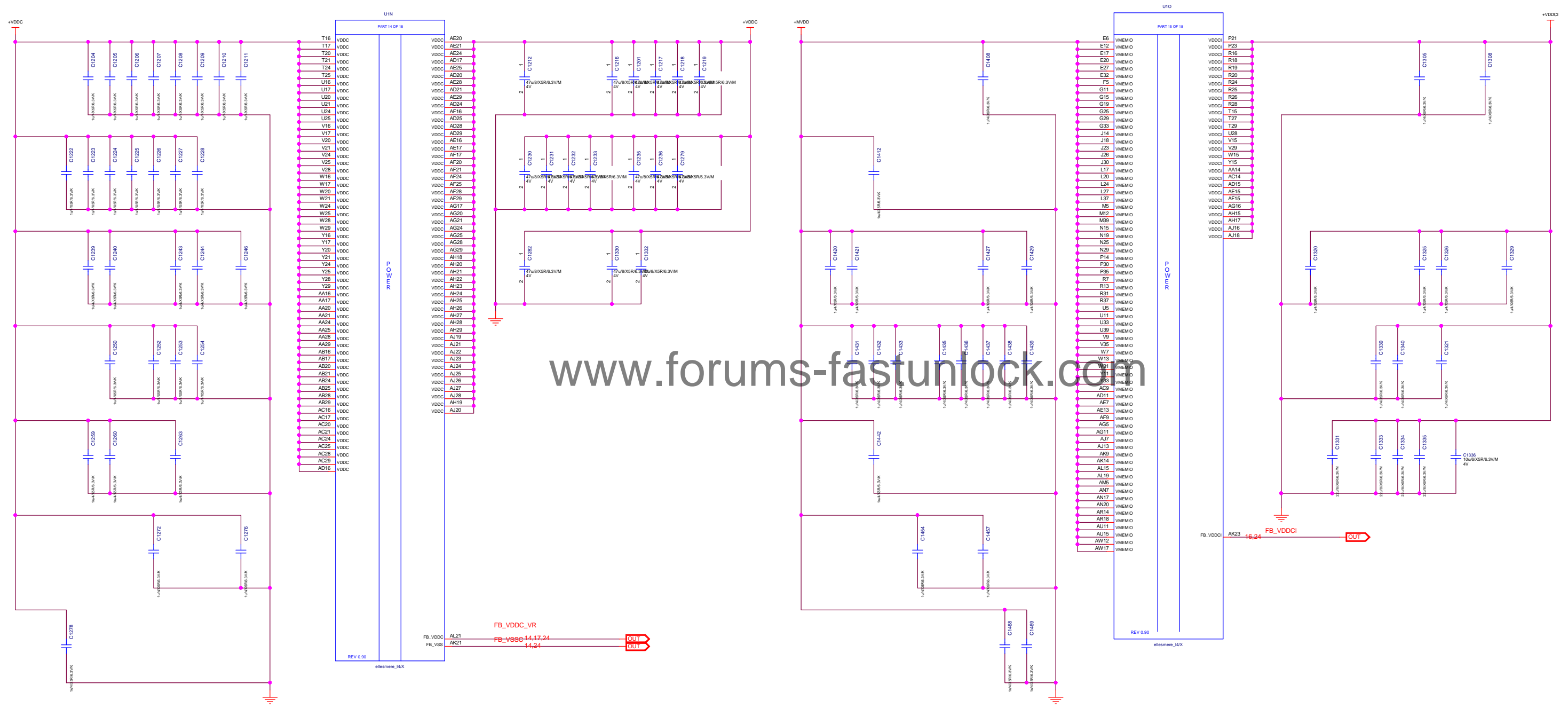

www.forums-fastunlock.com

GIGABYTE		
Title PCI Express		
Size	Document Number	Rev
Custom	GV-RX570GAMING-8GD-MI	1.11
Date:	Friday, June 01, 2018	Sheet 12 of 29

(13) ELLESMERE GROUND

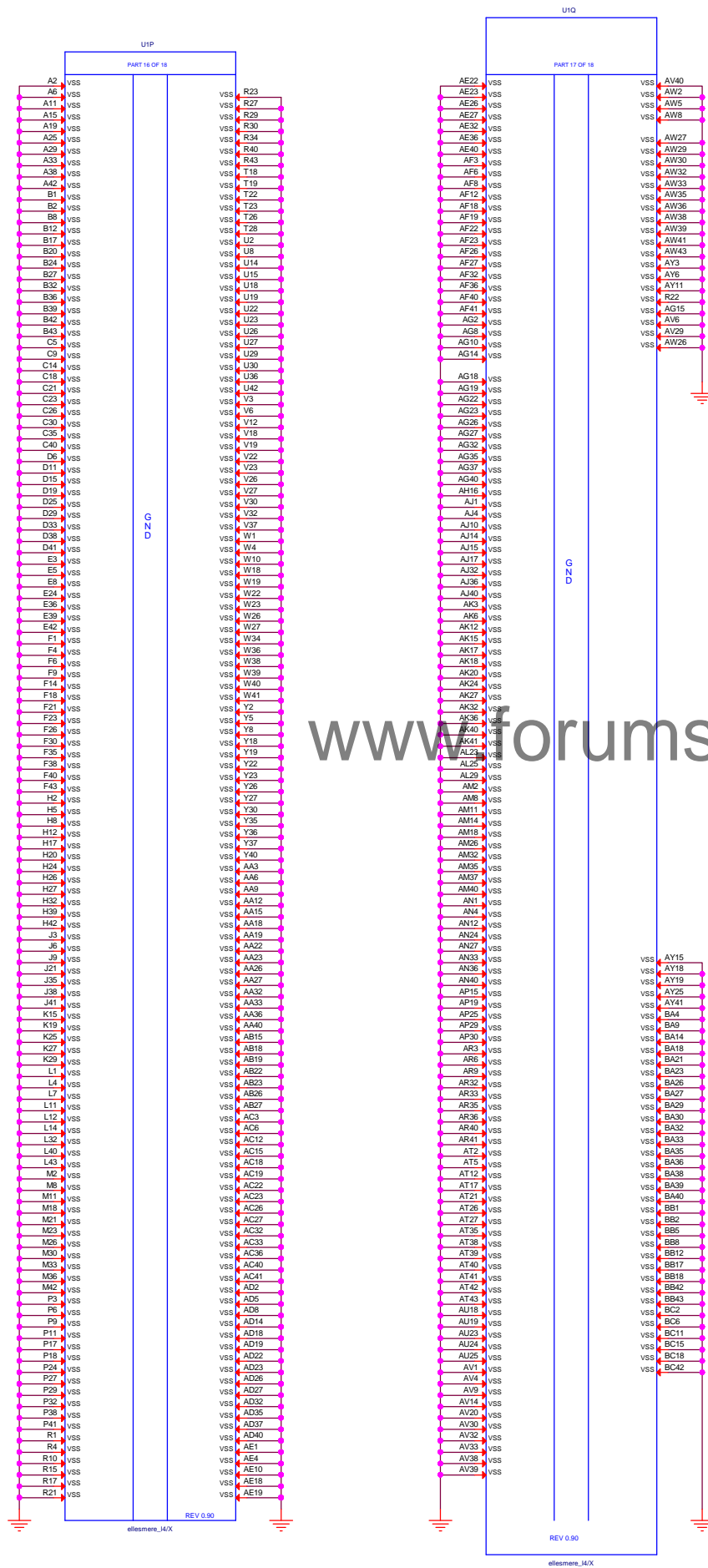

www.forums-fastunlock.com

GIGABYTE			
Title ELLESMERE GND			
Size	Document Number	Rev	
Custom	GV-RX570GAMING-8GD-MI	1.11	
Date:	Friday, June 01, 2018	Sheet	13 of 29

2017.09.21 Driver form RX580aorus-4GD Modify for Hardy

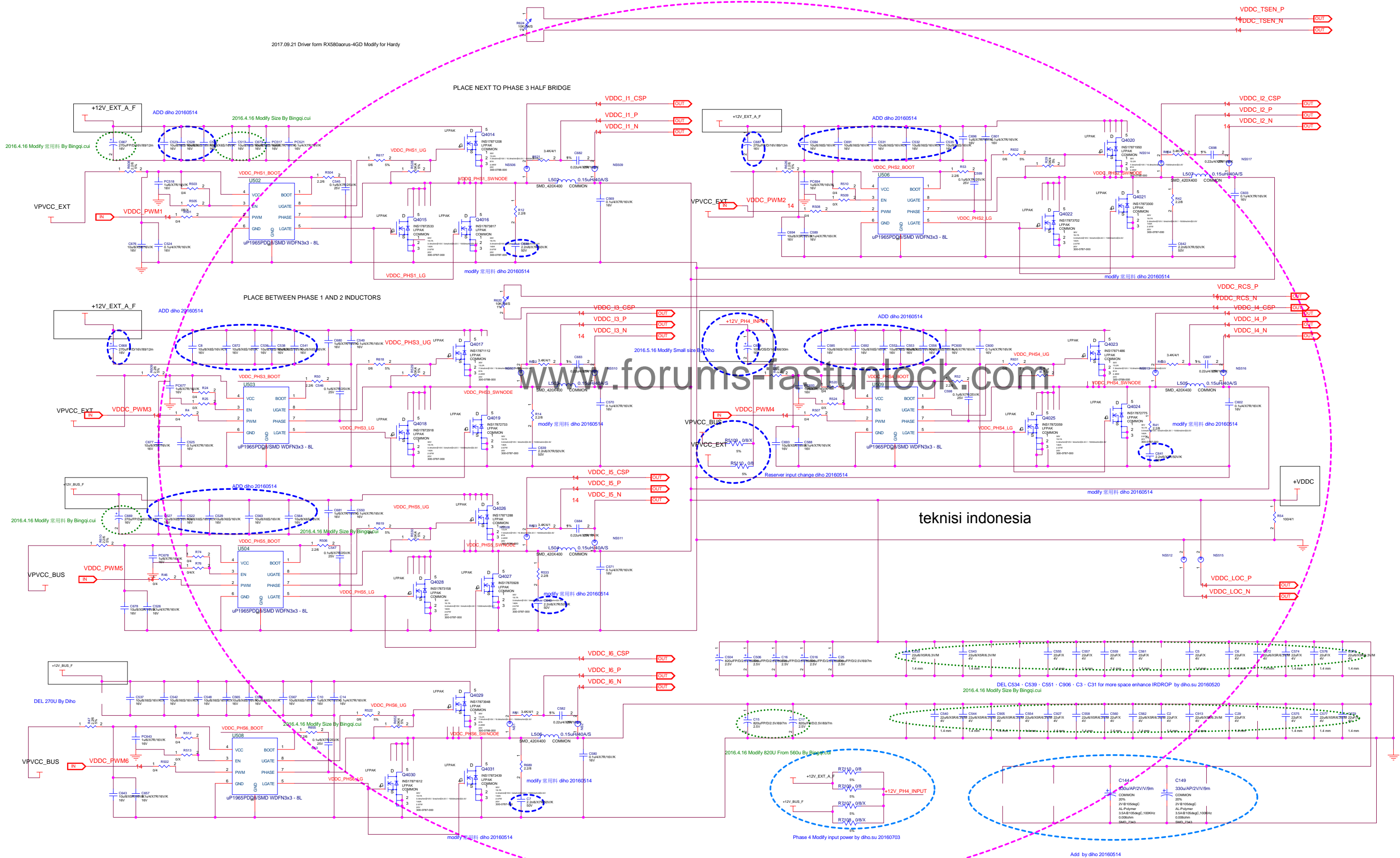

tekni indonesia

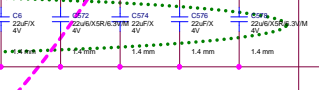
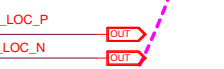
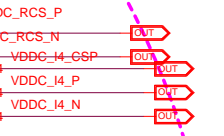
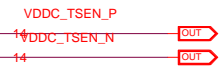

GIGABYTE			
File VDDC Driver			
Size	Document Number	Rev	
Custom	GV-RX570GAMING-8GD-MI	1.11	
Date:	Friday, June 01, 2016	Sheet	15 of 29

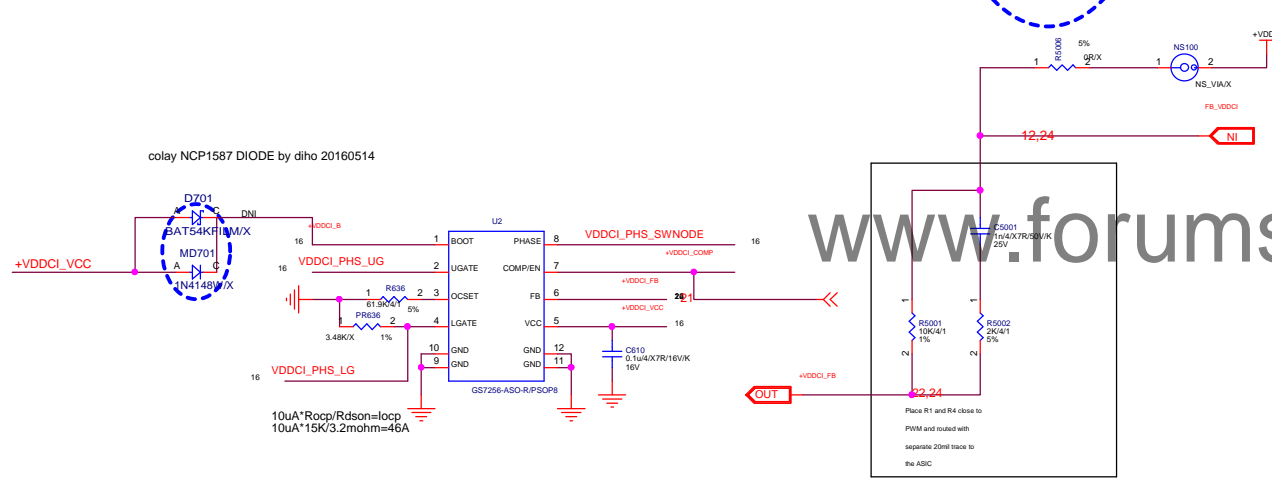
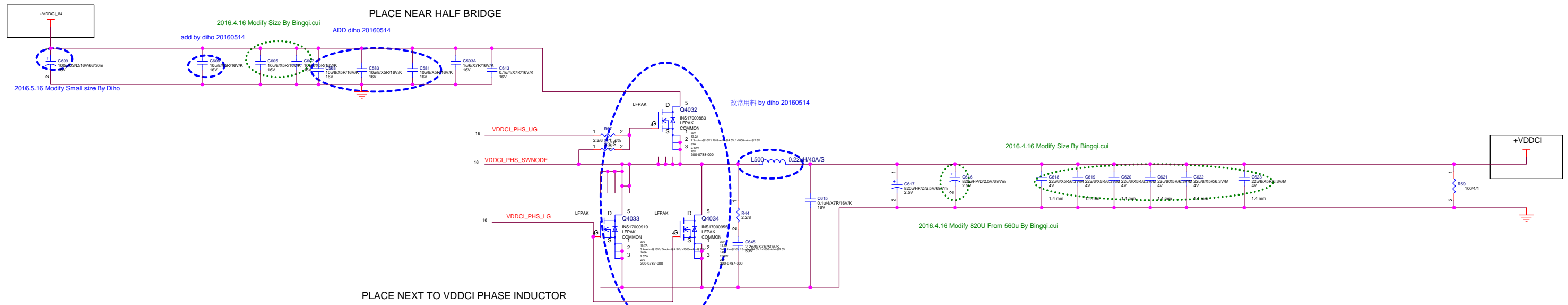

www.forums-fastunlock.com

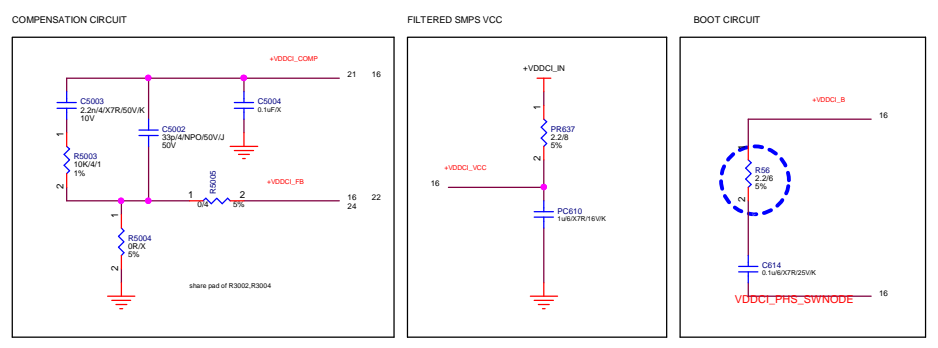

REGULATOR FOR VPVCC RAILS
IOUT MAX = 500mA

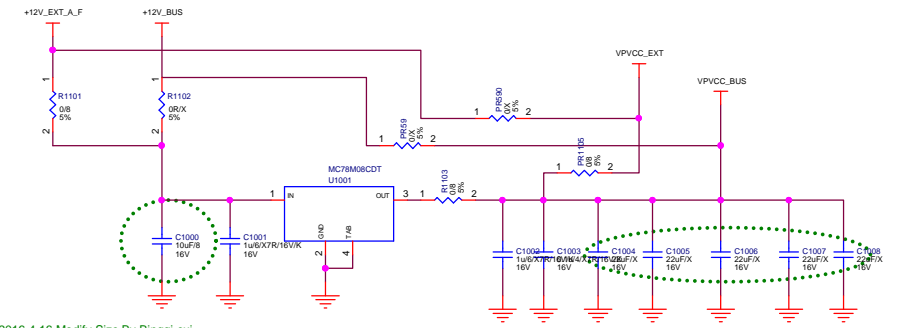

GIGABYTE			
File	VDDCI		
Size	Document Number	GV-RX570GAMING-8GD-MI	Rev 1.11
Date:	Friday, June 01, 2018	Sheet 16	of 29

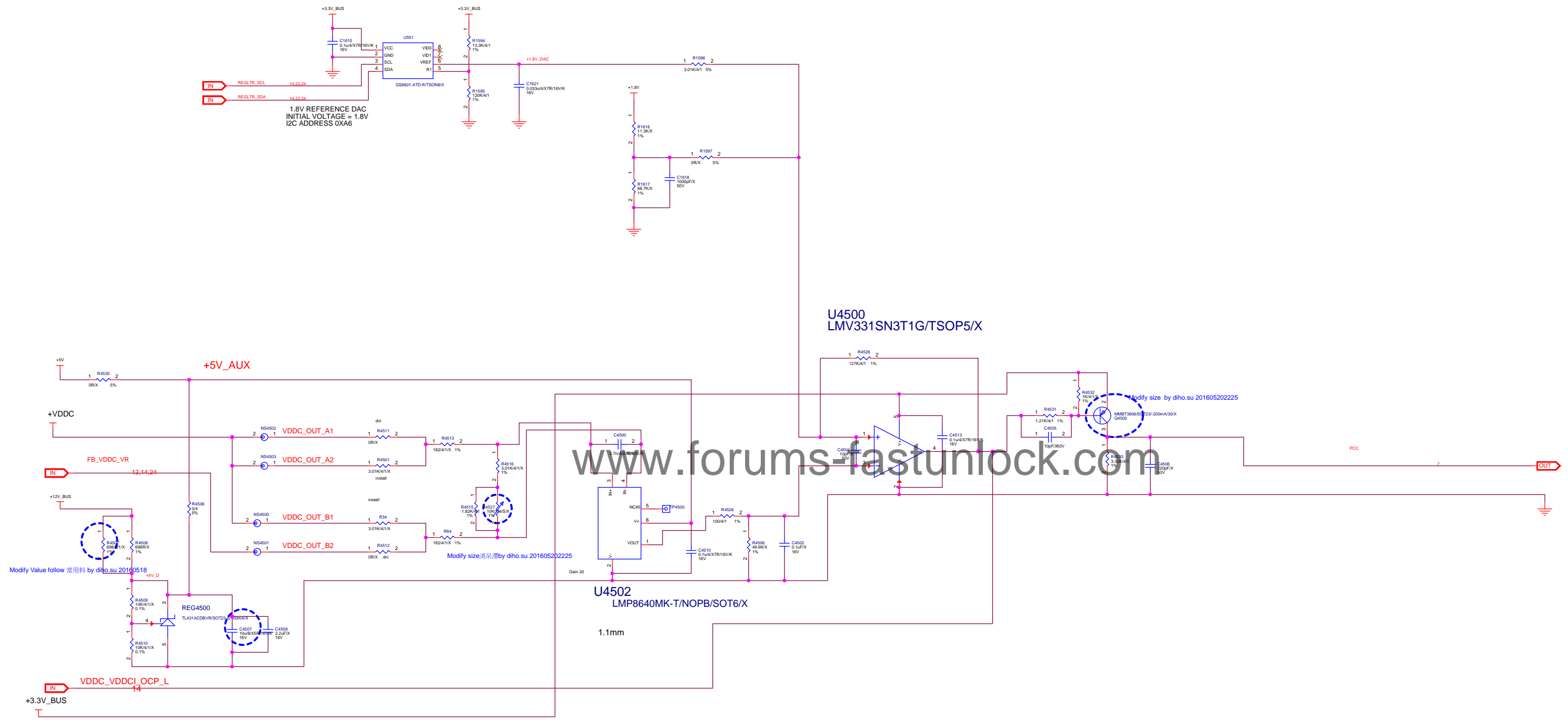

GIGABYTE			
Title		PCC VDDC	
Size	Document Number	Rev	
Custom	GV-RX570GAMING-8GD-MI	1.11	
Date:	Friday, June 01, 2018	Sheet	17 of 29

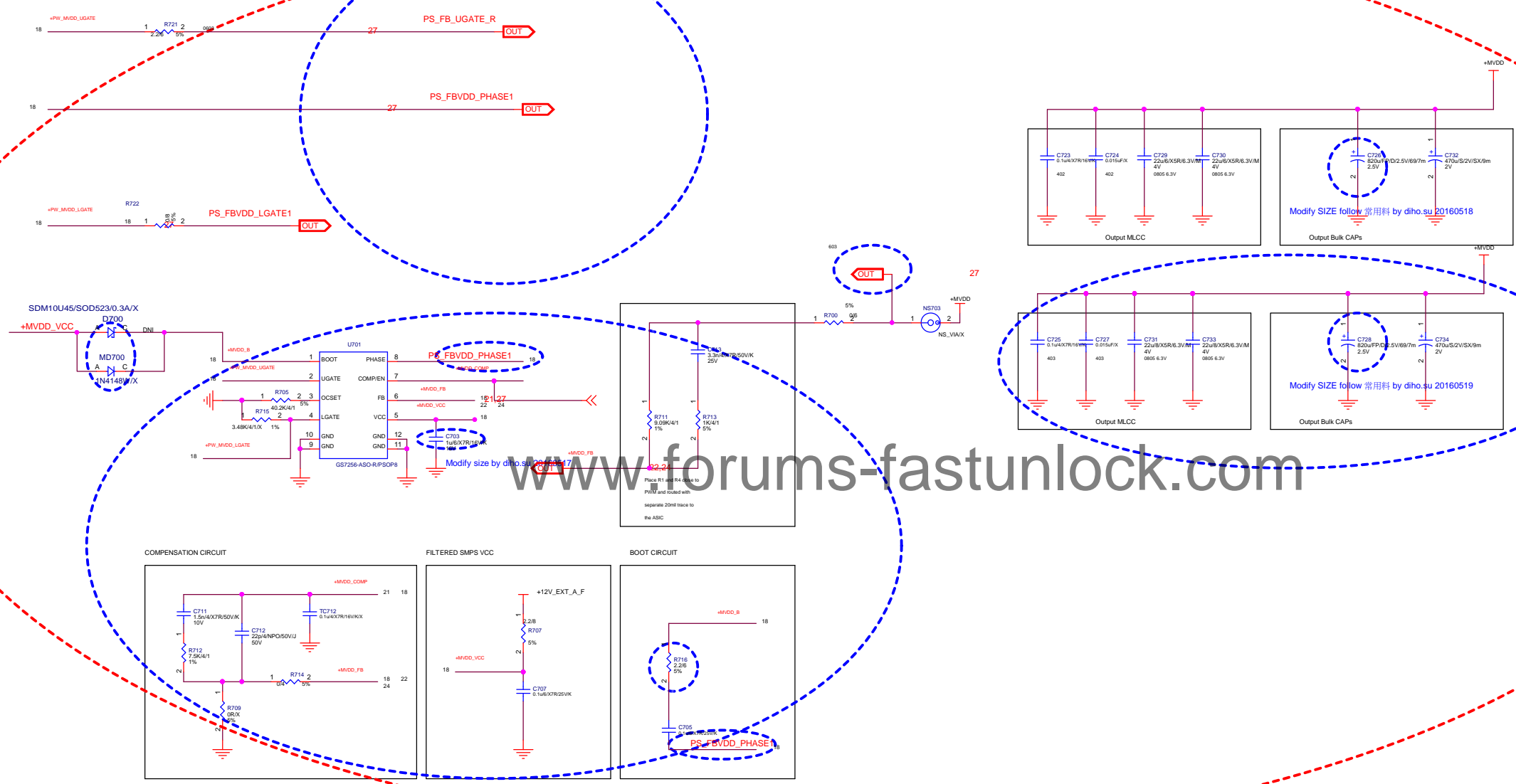

www.forums-fastunlock.com

/X Single phase power by diho.su 20160517

上件 by xiang.l@20160526

GIGABYTE			
Title		MVDD	
Size	Document Number	Rev	
Custom	GV-RX570GAMING-8GD-MI	1.11	
Date:	Friday, June 01, 2018	Sheet	18 of 29

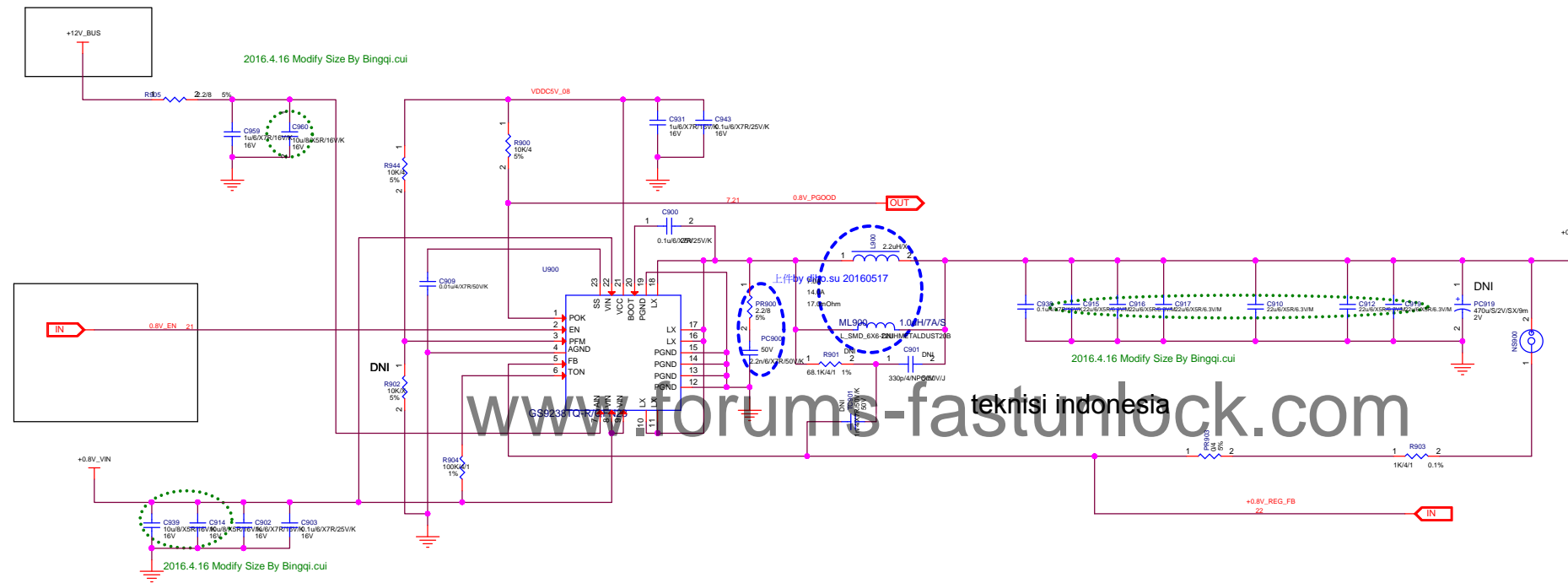

GIGABYTE			
Title	0.95V		
Size	Document Number	GV-RX570GAMING-8GD-MI	Rev 1.11
Date	Friday, June 01, 2018	Sheet 19	of 29

(18) SMALL RAIL REGULATORS

LDO #1: VIN = 3.0V TO 3.6V MAX VOUT = +1.8V +/- 2% IOUT = 1.3A RMS MAX
 PCB: 50 TO 70mm SQ. COPPER AREA FOR COOLING

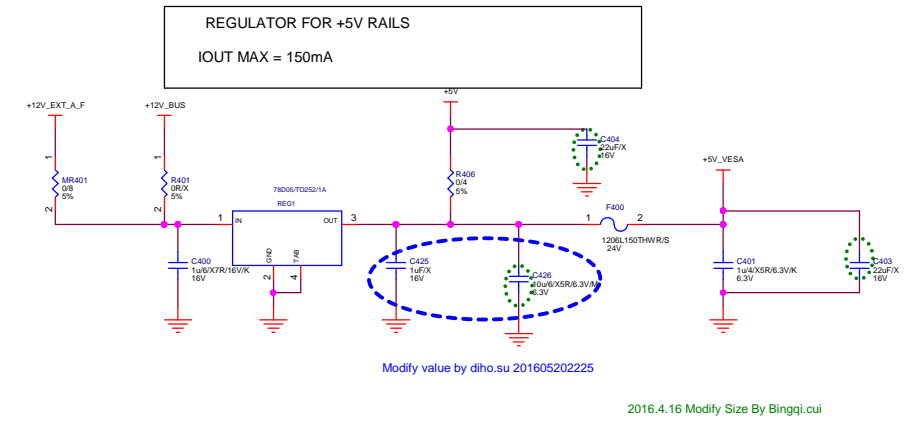
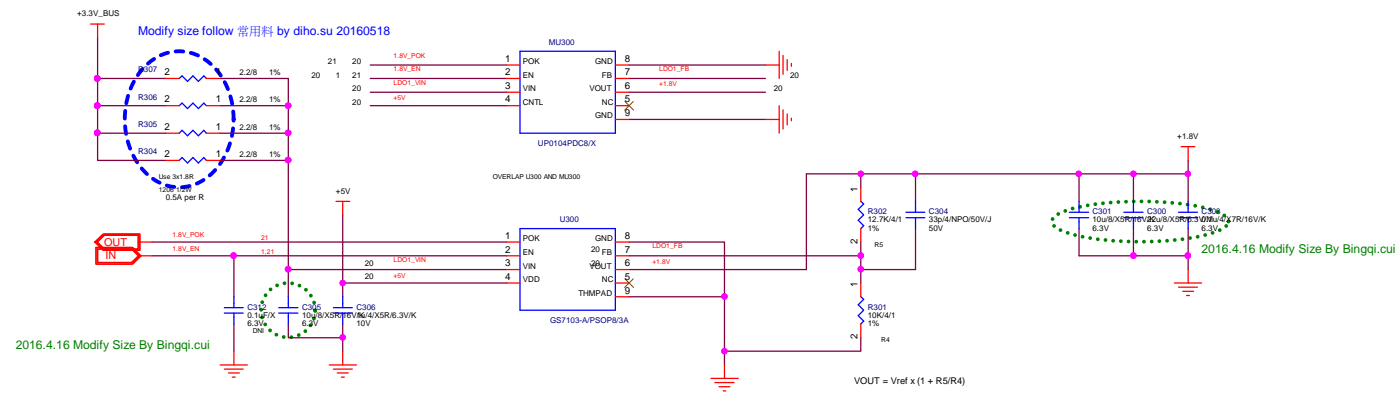

www.forums-fastunlock.com

GIGABYTE			
Title SMALL RAIL REGULATORS			
Size	Document Number	Rev	
Custom	GV-RX570GAMING-8GD-MI	1.11	
Date:	Friday, June 01, 2018	Sheet	20 of 29

(19) POWER MANAGEMENT

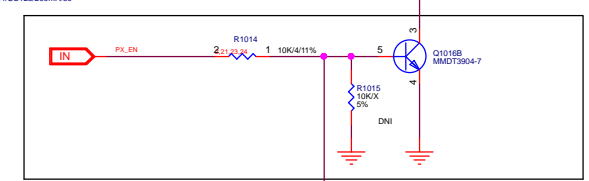
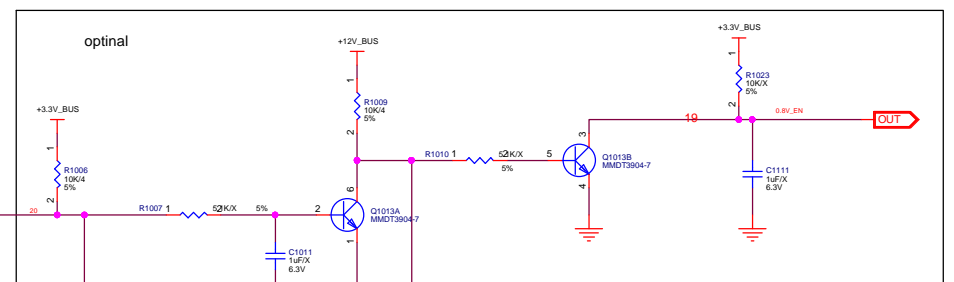
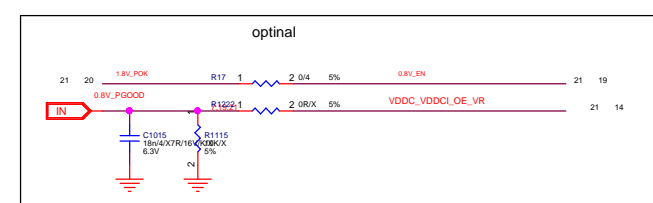
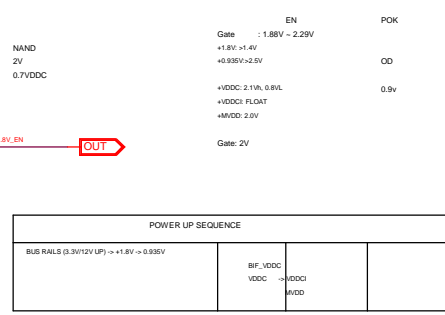
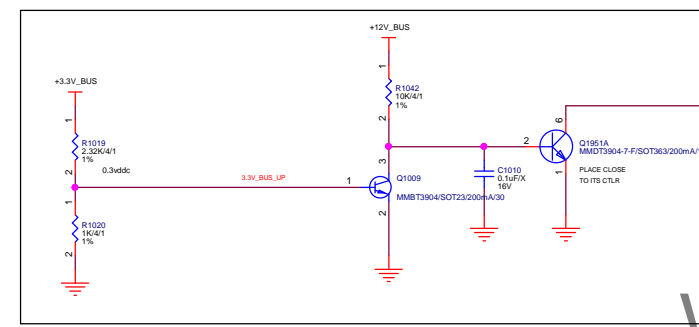
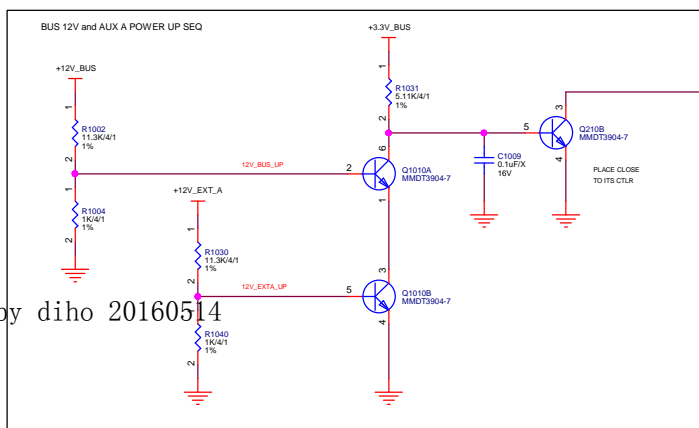
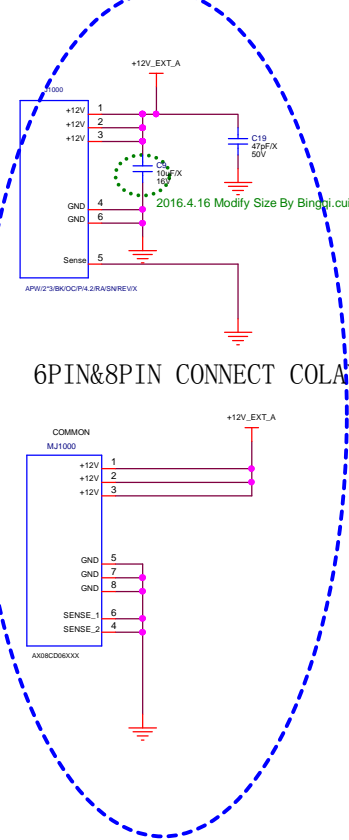

www.forums-fastunlock.com

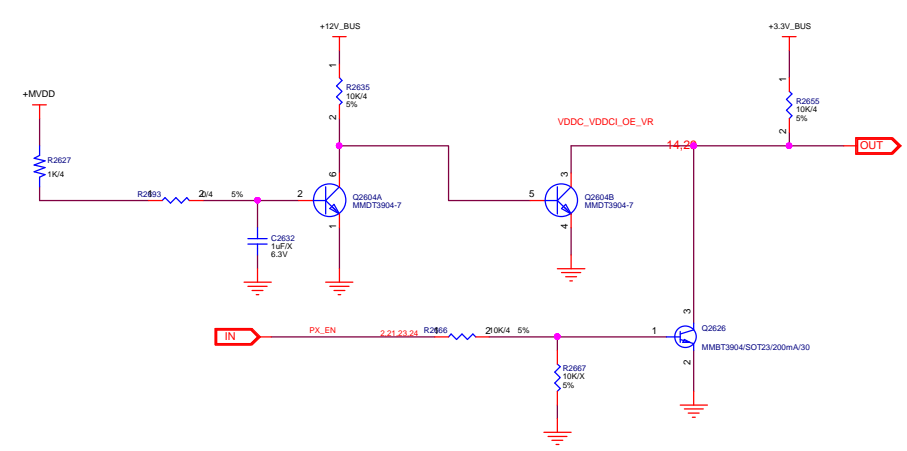
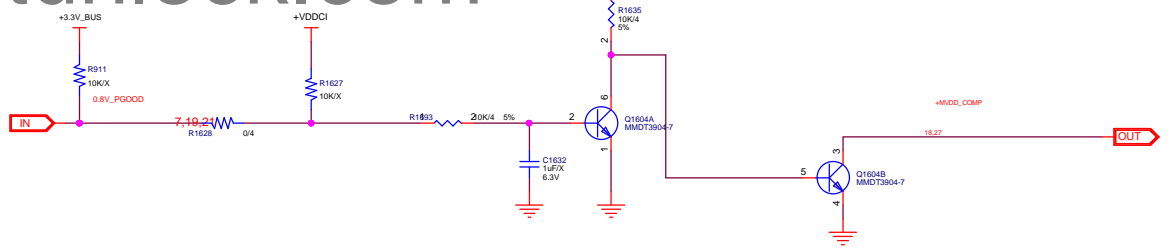
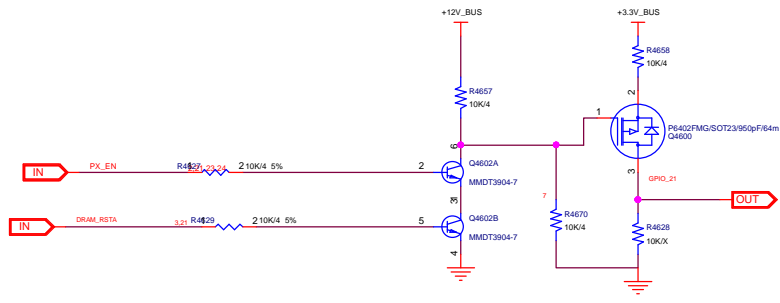
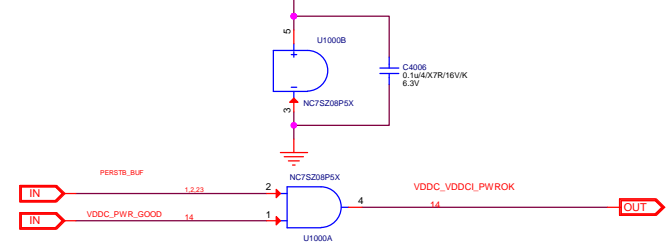
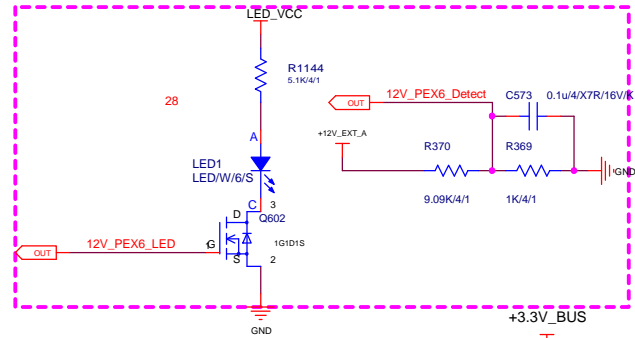
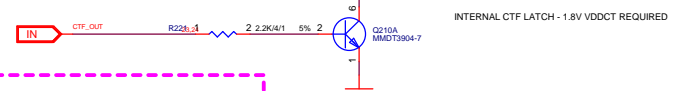

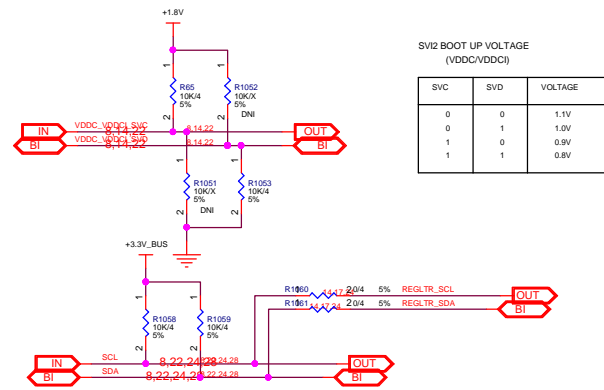

www.forums-fastunlock.com

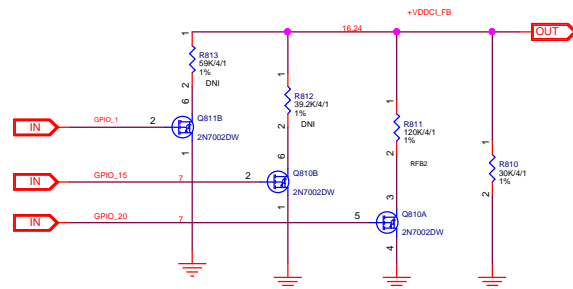
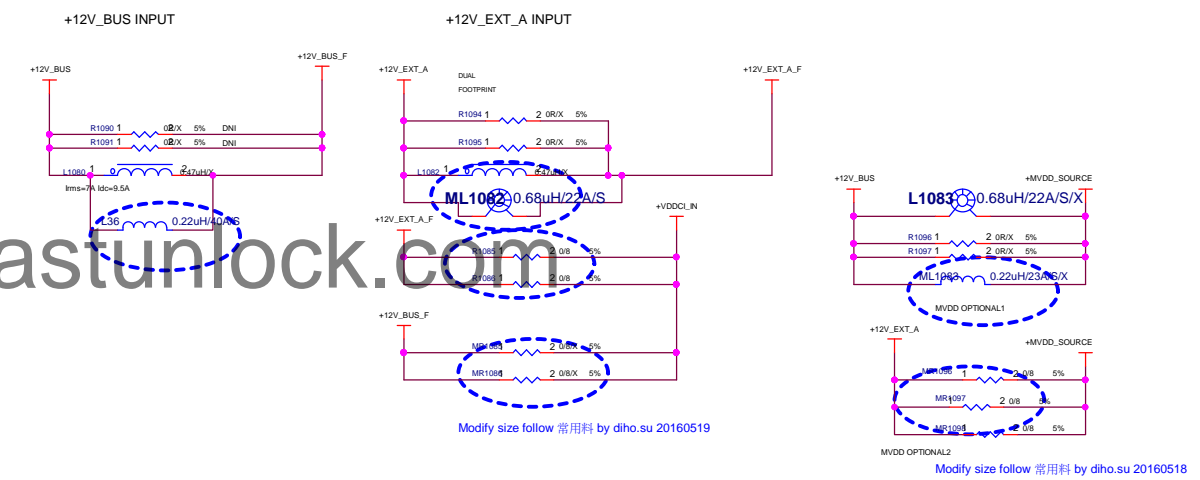

www.teknisi-indonesia.com

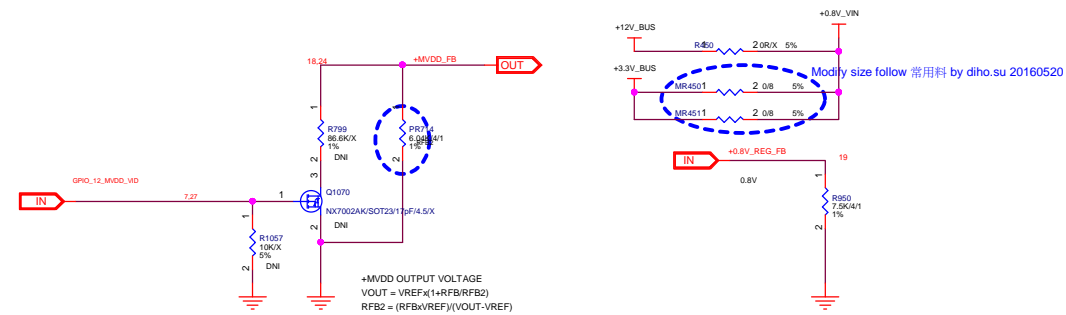

(21) DEBUG CIRCUITS

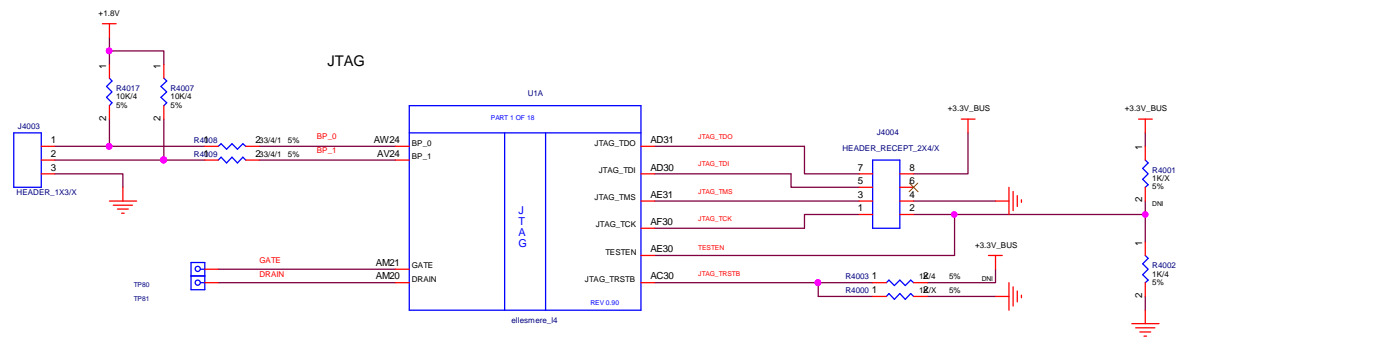

E-FUSE CAPABILITY
DEFAULT = GPIO-CONTROLLED (MANUAL OPTION AS BACK-UP)

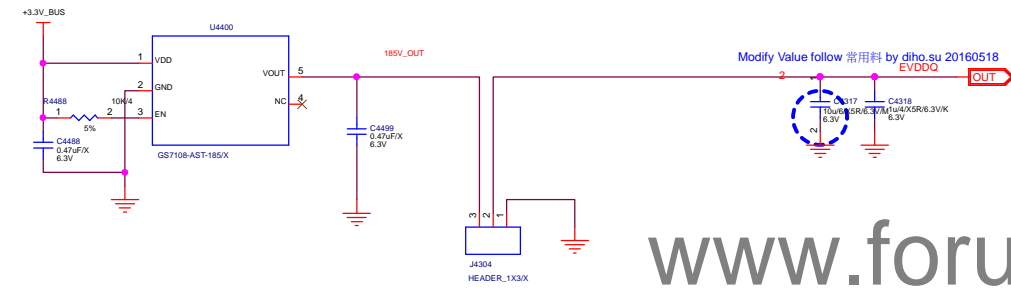

DIGITAL POTS

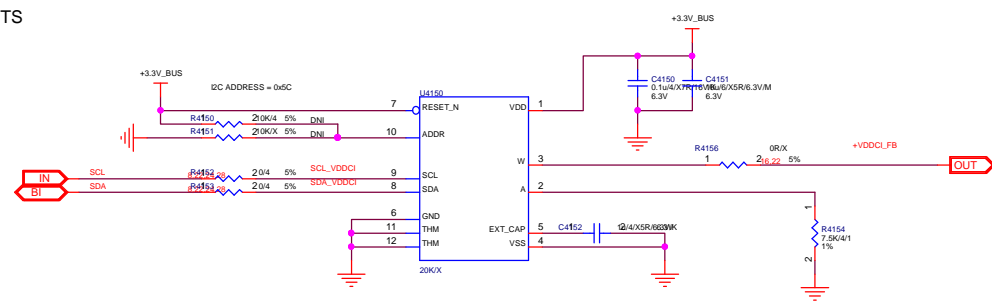

DIGITAL POTS

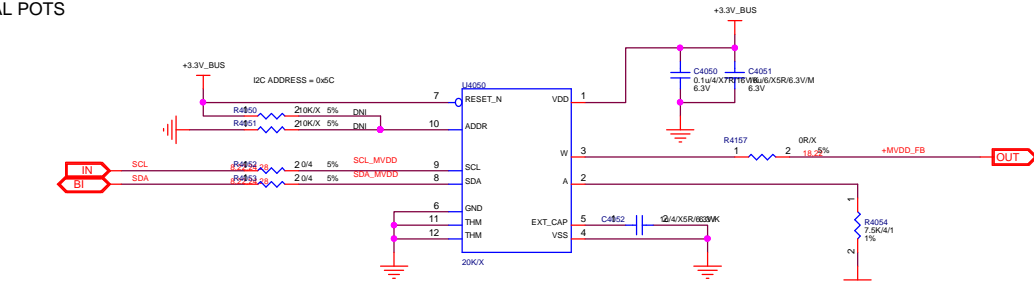

SWITCHES

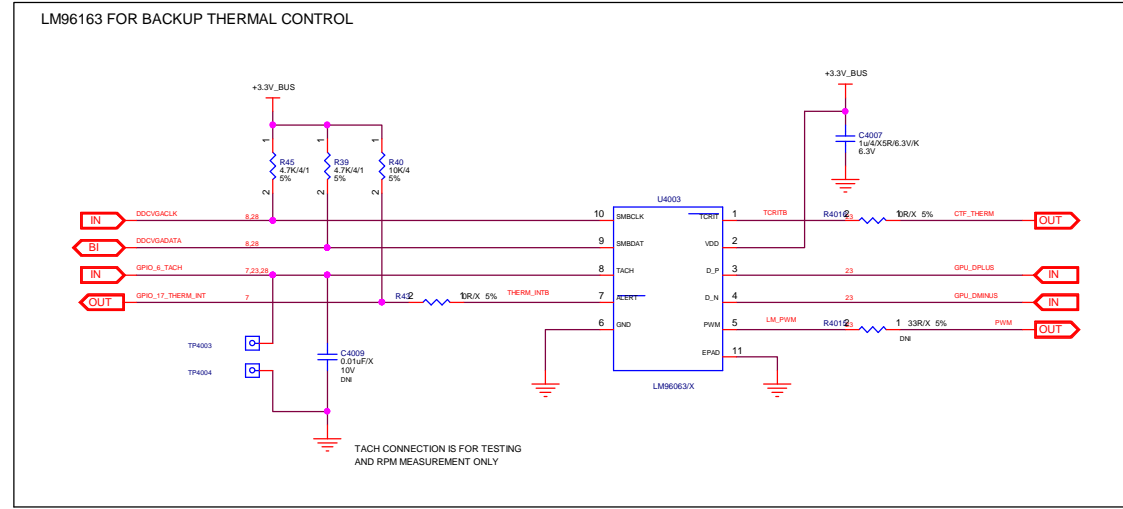
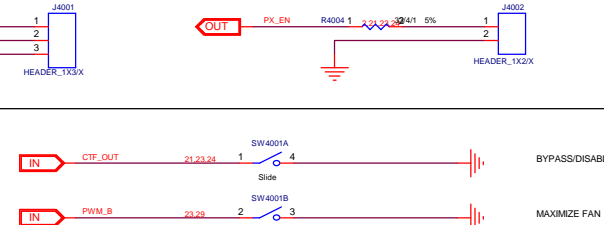

LED LIGHTS

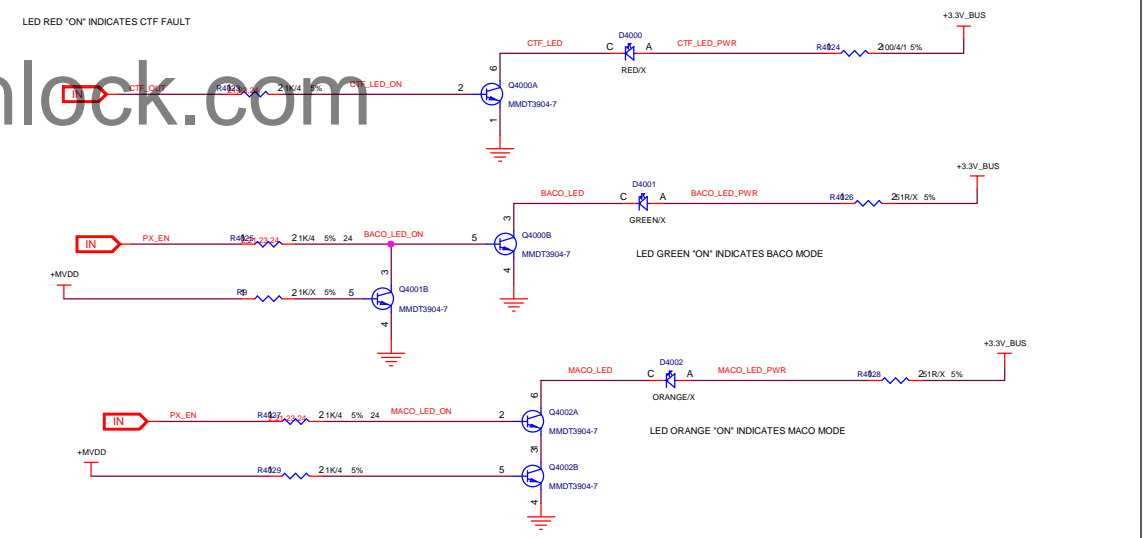

VTMM - TEST CONNECTOR FOR VOLTAGE MEASUREMENTS

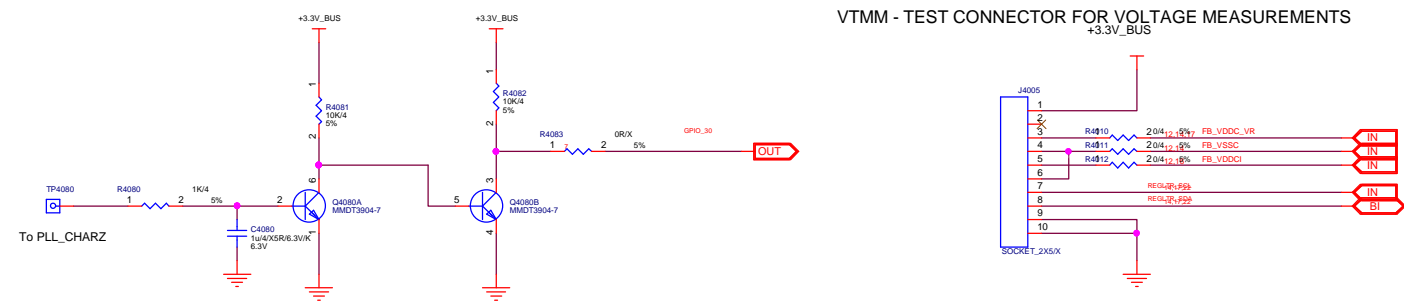

GIGABYTE			
Title	DEBUG CIRCUITS		
Size	Document Number	GV-RX570GAMING-8GD-MI	Rev 1.11
Date:	Friday, June 01, 2018	Sheet 24	of 29

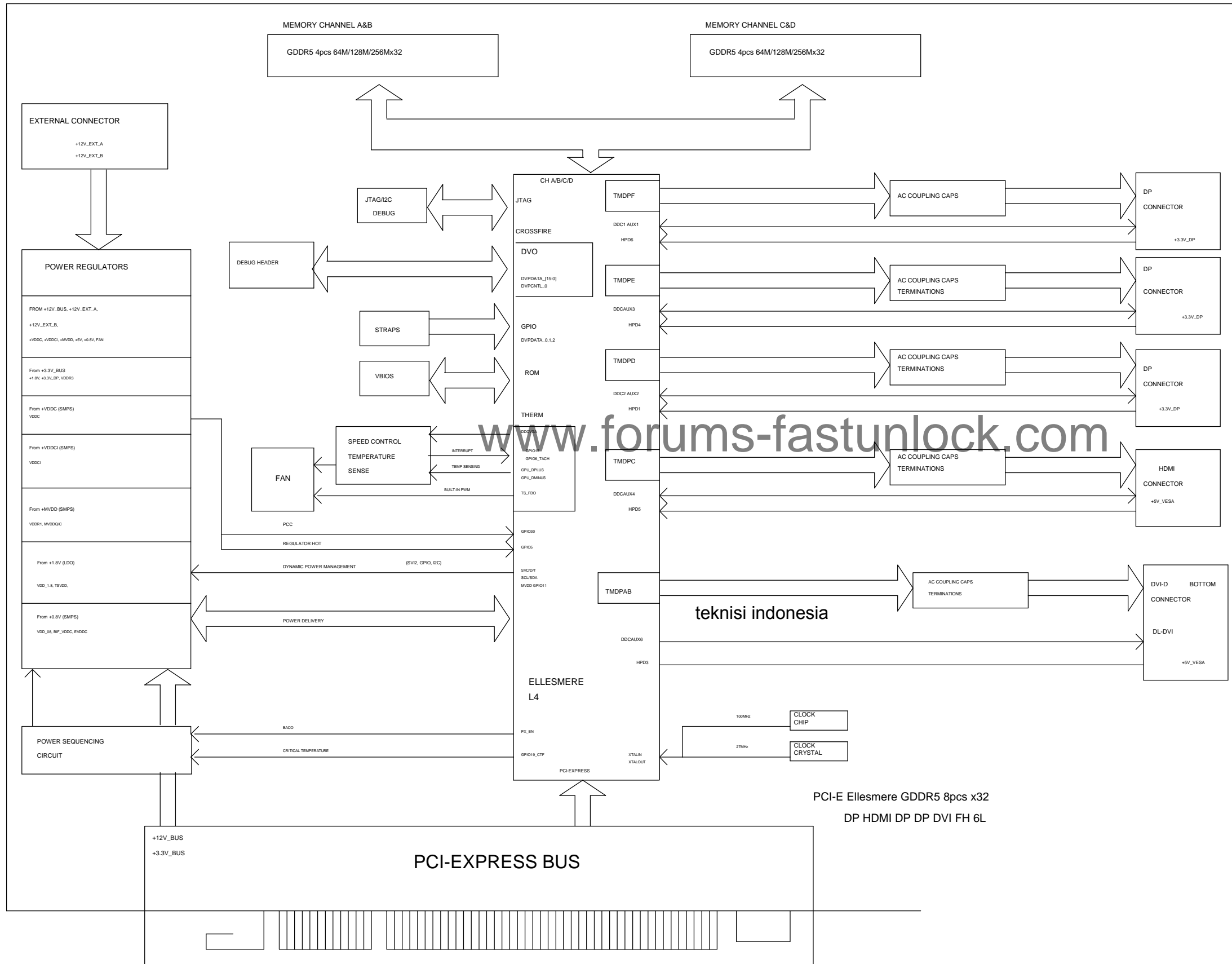

www.forums-fastunlock.com

teknisi indonesia

PCI-E Ellesmere GDDR5 8pcs x32
DP HDMI DP DP DVI FH 6L

GIGABYTE			
Title BLOCK DIAGRAM			
Size	Document Number	Rev	
Custom	GV-RX570GAMING-8GD-MI	1.11	
Date:	Friday, June 01, 2018	Sheet	25 of 29

0	00A	000001	
1	00B	100000	1. Add DPDI for dynamic VDDC 2. Update VDDC driver sequence
2	00C	000000	HDMI: - add series resistor R1880 -R1887 - add pull down inductor L1880 -L1887 remove C405, C403, VR400,C410,C414,R405
3	00D	000000	Modify GBT Design

www.forums-fastunlock.com

GIGABYTE			
Title			
BLOCK DIAGRAM			
Size	Document Number	Rev	
Custom	GV-RX570GAMING-8GD-MI	1.11	
Date:	Friday, June 01, 2018	Sheet	26 of 29

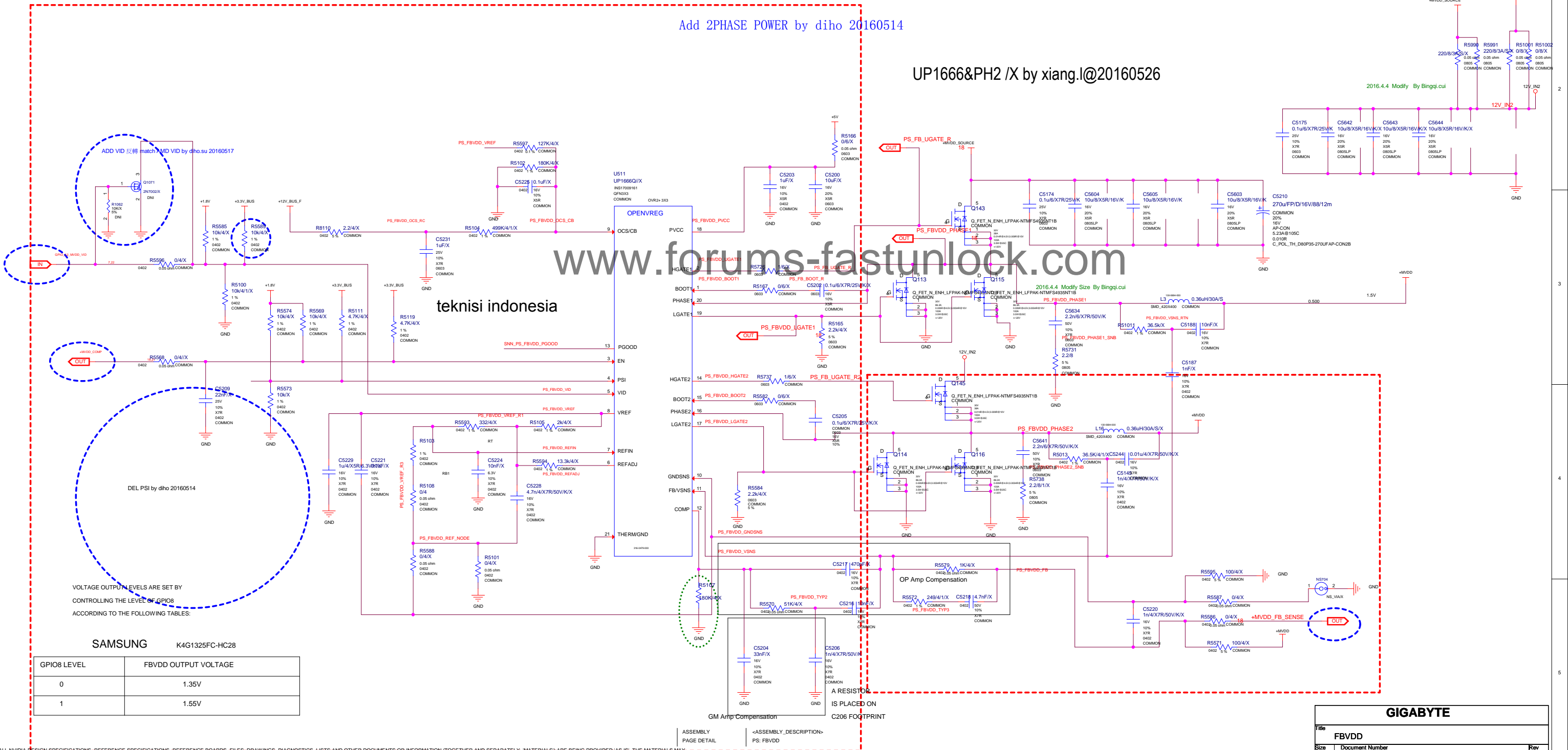

SAMSUNG K4G1325FC-HC28

GPIO8 LEVEL	FBVDD OUTPUT VOLTAGE
0	1.35V
1	1.55V

GIGABYTE		
Title	FBVDD	
Size	Document Number	Rev
Custom	GV-RX570GAMING-8GD-MI	1.11
Date	Friday, June 01, 2016	Sheet 27 of 29

ALL NVIDIA DESIGN SPECIFICATIONS, REFERENCE SPECIFICATIONS, REFERENCE BOARDS, FILES, DRAWINGS, DIAGNOSTICS, LISTS, AND OTHER DOCUMENTS OR INFORMATION TOGETHER AND SEPARATELY, MATERIALS ARE BEING PROVIDED AS IS. THE MATERIALS MAY CONTAIN KNOWN AND UNKNOWN VIOLATIONS OR DEVIATIONS OF INDUSTRY STANDARDS AND SPECIFICATIONS. NVIDIA MAKES NO WARRANTIES, EXPRESSED, IMPLIED, STATUTORY OR OTHERWISE WITH RESPECT TO THE MATERIALS OR OTHERWISE, AND EXPRESSLY DISCLAIMS ALL IMPLIED WARRANTIES INCLUDING, WITHOUT LIMITATION, THE WARRANTIES OF DESIGN, OF NON-INFRINGEMENT, MERCHANTABILITY OR FITNESS FOR A PARTICULAR PURPOSE, OR ARISING FROM A COURSE OF DEALING, TRADE USAGE, TRADE PRACTICE, OR INDUSTRY STANDARDS.

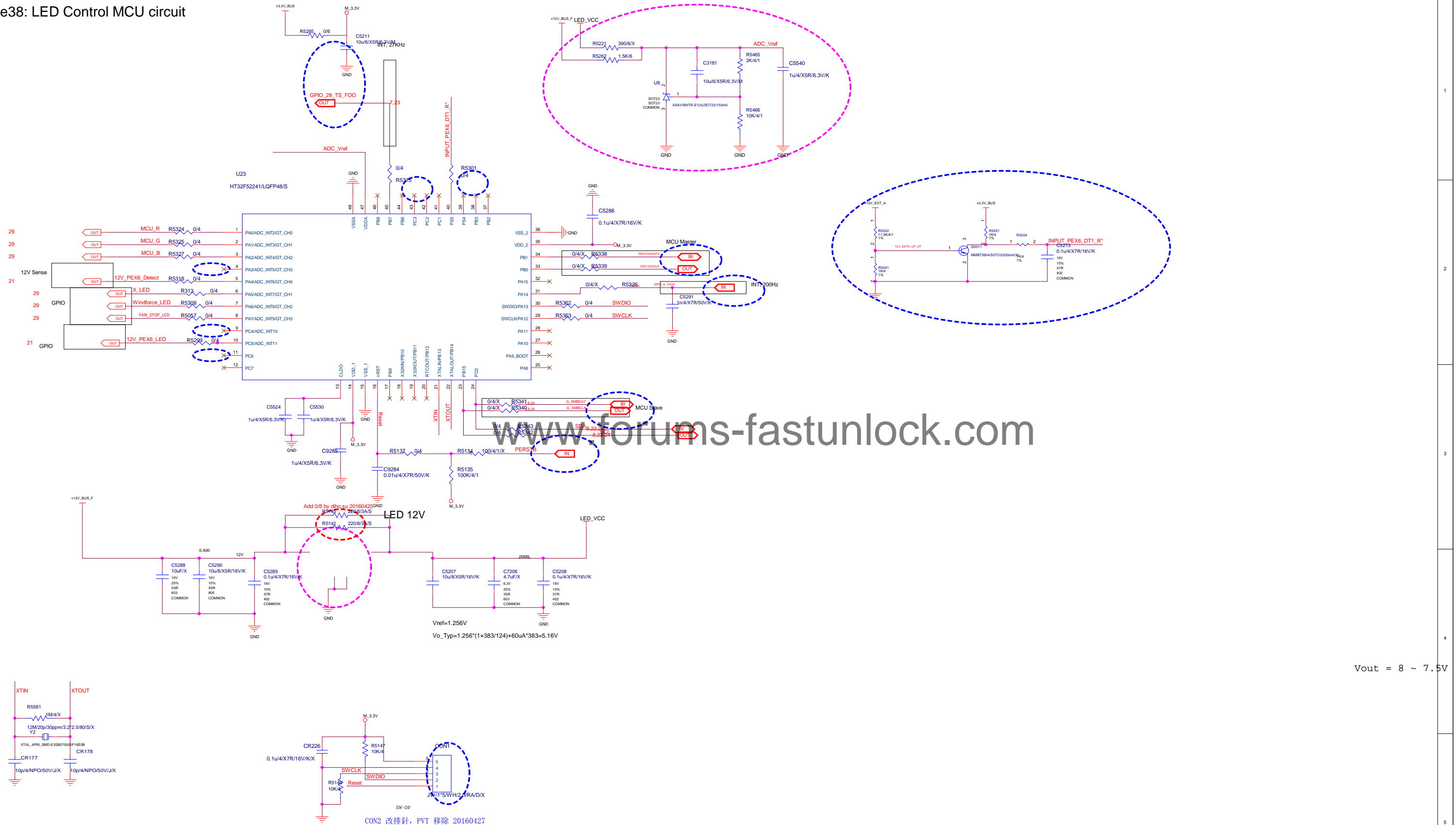

Vout = 8 ~ 7.5V

ALL NVIDIA DESIGN SPECIFICATIONS, REFERENCE SPECIFICATIONS, REFERENCE BOARDS, FILES, DRAWINGS, DIAGNOSTICS, LISTS AND OTHER DOCUMENTS OR INFORMATION (TOGETHER AND SEPARATELY, 'MATERIALS') ARE BEING PROVIDED 'AS IS'. THE MATERIALS MAY CONTAIN KNOWN AND UNKNOWN VIOLATIONS OR DEVIATIONS OF INDUSTRY STANDARDS AND SPECIFICATIONS. NVIDIA MAKES NO WARRANTIES, EXPRESSED, IMPLIED, STATUTORY OR OTHERWISE WITH RESPECT TO THE MATERIALS OR OTHERWISE, AND EXPRESSLY DISCLAIMS ALL IMPLIED WARRANTIES INCLUDING, WITHOUT LIMITATION, THE WARRANTIES OF DESIGN, OF NONINFRINGEMENT, MERCHANTABILITY OR FITNESS FOR A PARTICULAR PURPOSE, OR ARISING FROM A COURSE OF DEALING, TRADE USAGE, TRADE PRACTICE, OR INDUSTRY STANDARDS.

Title		
Size	Document Number	Rev
CustomLED	GV-RX570GAMING-8GD-MI	1.11
Date:	Friday, June 01, 2018	Sheet 28 of 29

Add MOS VRHOT CIRCUIT

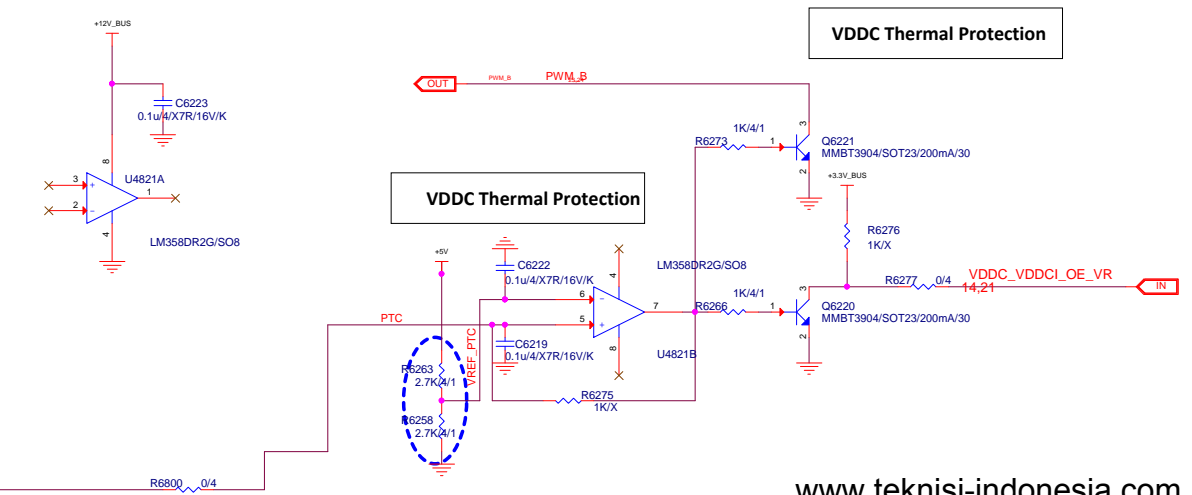
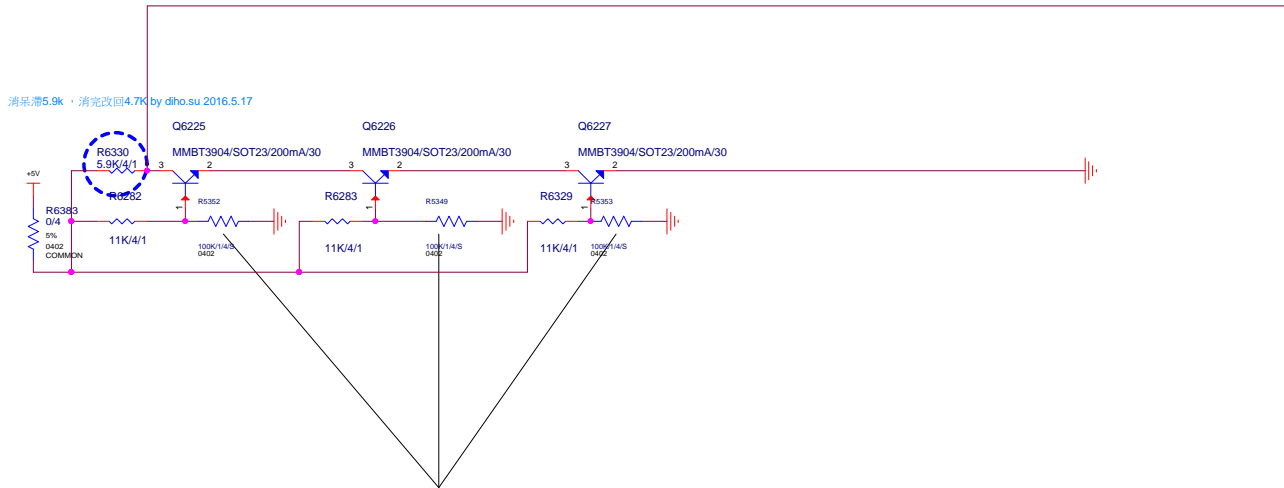

www.teknisi-indonesia.com

www.forums-fastunlock.com

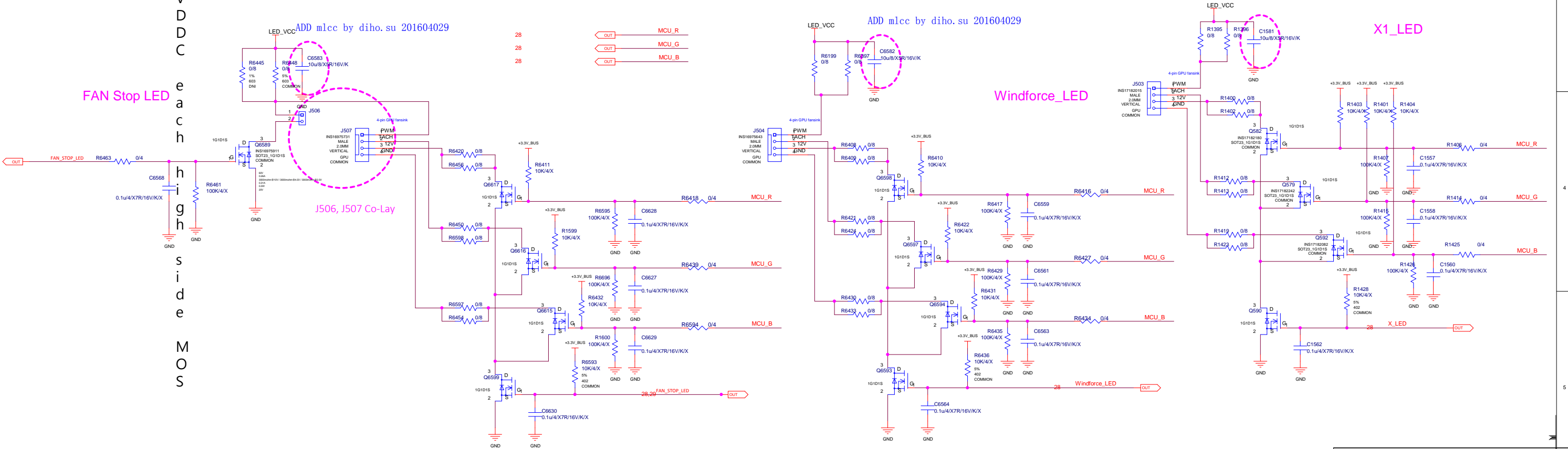

ALL NVIDIA DESIGN SPECIFICATIONS, REFERENCE SPECIFICATIONS, REFERENCE BOARDS, FILES, DIAGNOSTICS, LISTS AND OTHER DOCUMENTS (TOGETHER AND SEPARATELY, "MATERIALS") ARE BEING PROVIDED "AS IS". THE MATERIALS MAY CONTAIN KNOWN AND UNKNOWN VIOLATIONS OR DEVIATIONS OF INDUSTRY STANDARDS AND SPECIFICATIONS. NVIDIA MAKES NO WARRANTIES, EXPRESSED, IMPLIED, STATUTORY OR OTHERWISE WITH RESPECT TO THE MATERIALS OR OTHERWISE, AND EXPRESSLY DISCLAIMS ALL IMPLIED WARRANTIES INCLUDING, WITHOUT LIMITATION, THE WARRANTIES OF DESIGN, OF NONINFRINGEMENT, MERCHANTABILITY OR FITNESS FOR A PARTICULAR PURPOSE, OR ARISING FROM A COURSE OF DEALING, TRADE USAGE, TRADE PRACTICE, OR INDUSTRY STANDARDS.

Title		
Size	Document Number	Rev
Customer	FAN GV-RX570GAMING-8GD-MI	1.11
Date:	Friday, June 01, 2018	Sheet 29 of 29