

# OP9 (14")

## Intel Brasswell-M Platform Block Diagram

+3VS5/+5VS5	PG.28
MOIC	PG.30
CPU Core	PG.312,32
DDR3L	PG.29
Charger	PG.27

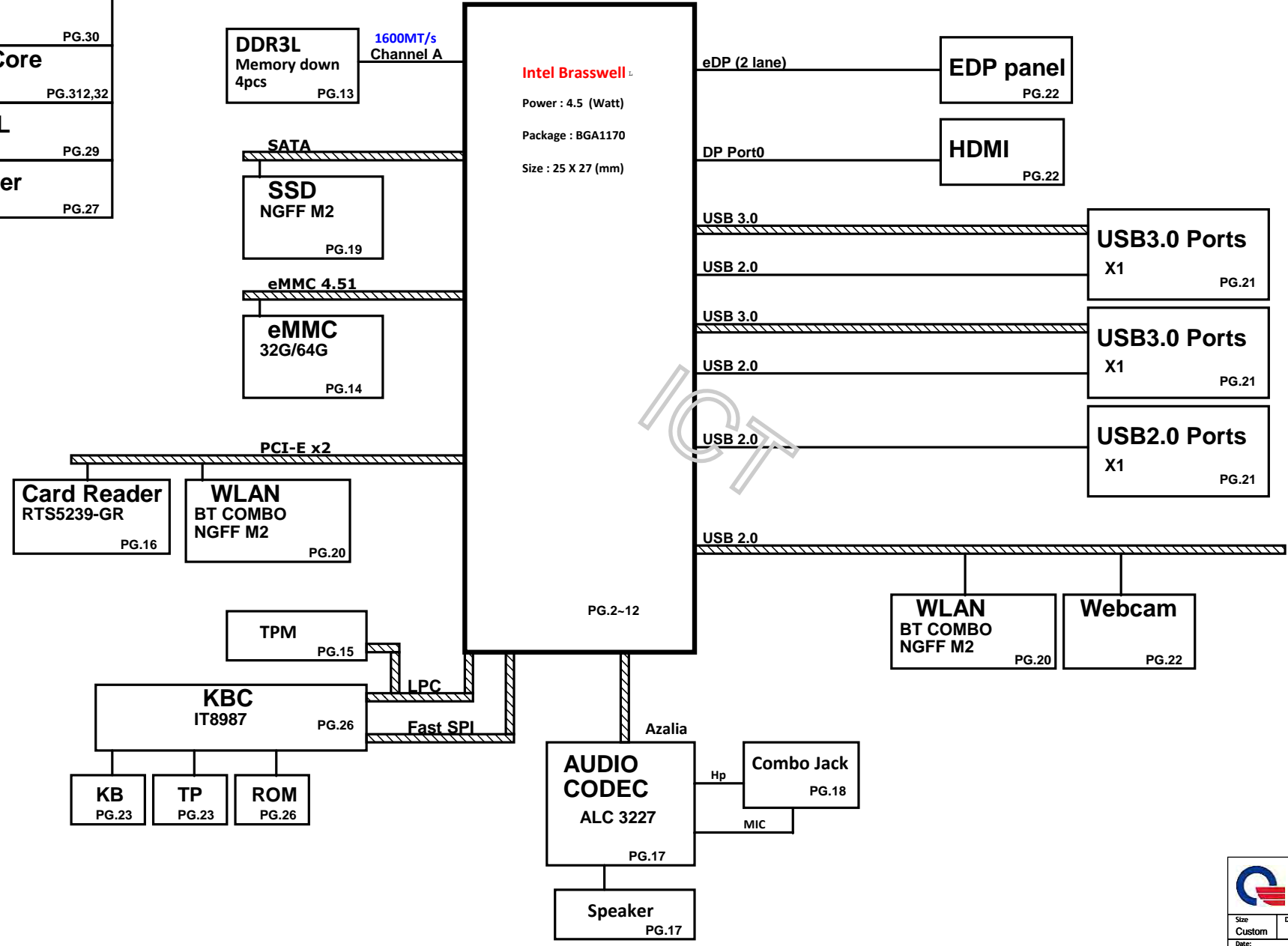

PLACE TWO 4.7K RESISTORS CLOSE TO CPU PINS ON M\_VREF  
ROUTE THE VREF POWER SIGNALS WITH THICK TRACES

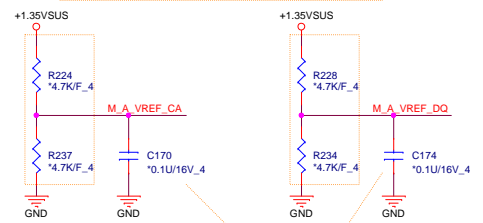

PLACE 0.1UF CAP CLOSE TO CPU

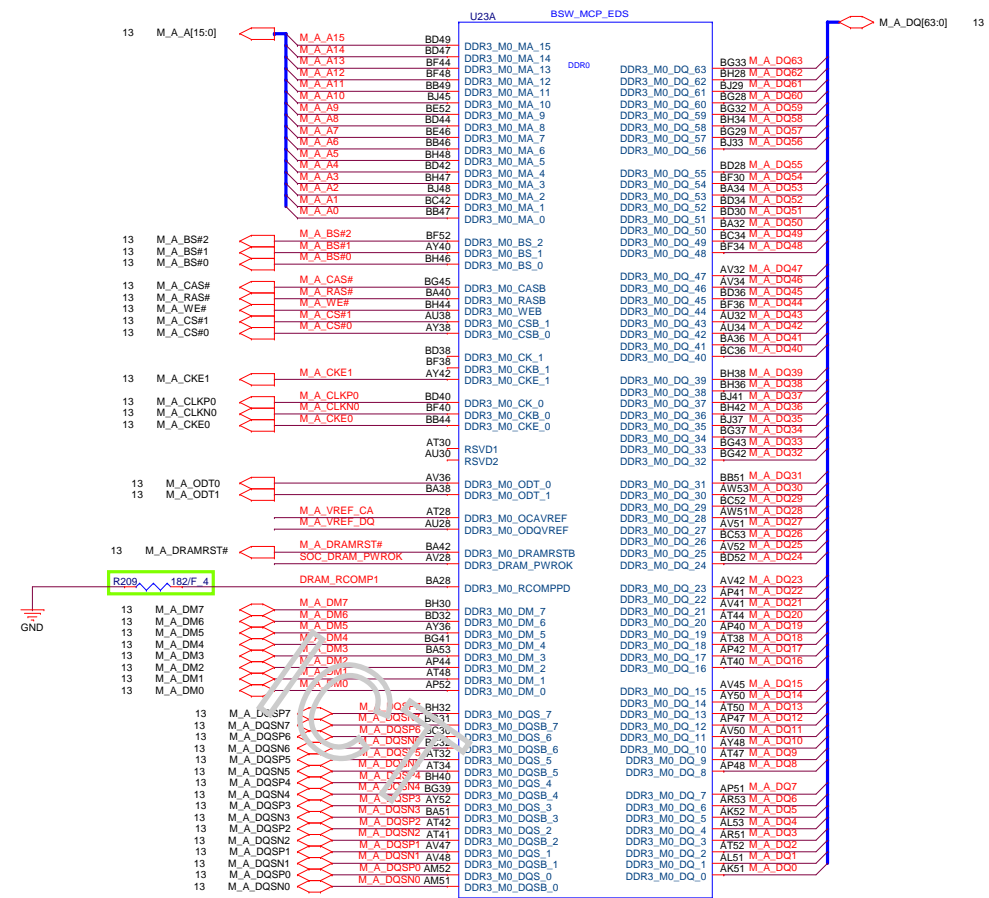

\*BSW\_MCP\_EDS 1 OF 13

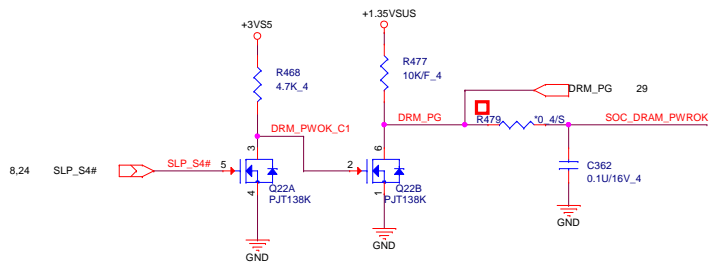

**Quanta Computer Inc.**  
PROJECT : OP9

Size Custom	Document Number <b>Braswell-1 (DDR4)</b>	Rev. 1A
Date: Tuesday, June 07, 2016	Sheet : 2 of 37	

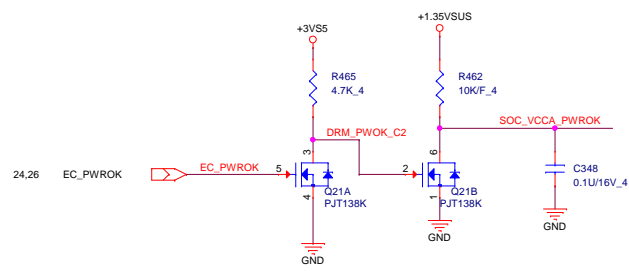
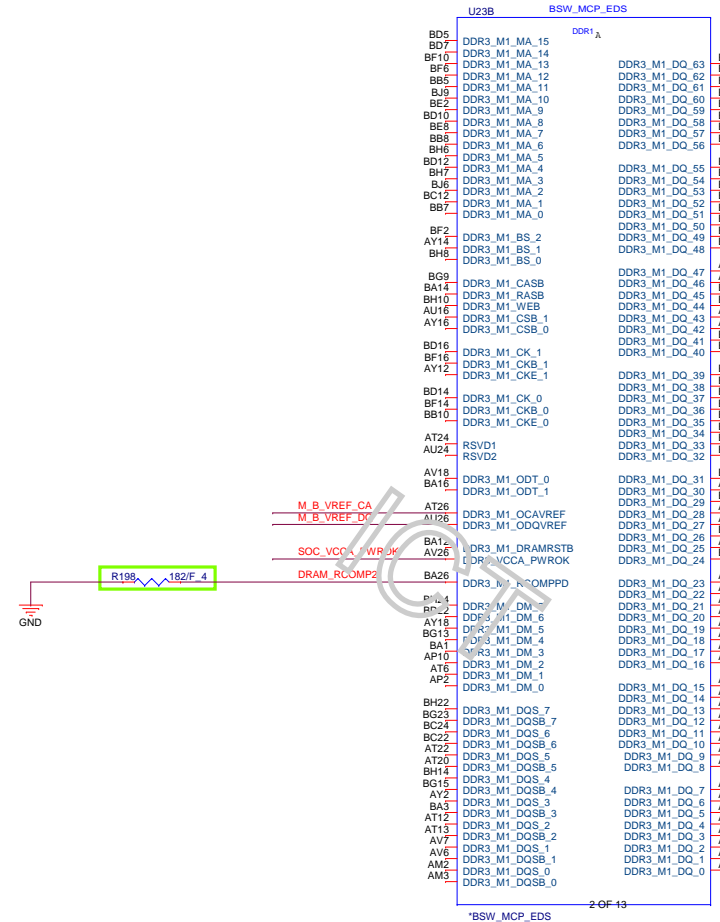
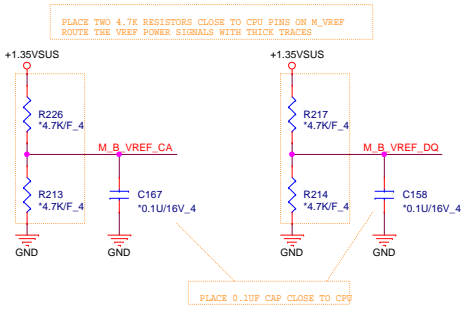

**Quanta Computer Inc.**

**PROJECT : OP9**

Size	Document Number	Rev.
Custom	Braswell-2 (DDR8)	1A
Date:	Tuesday, June 07, 2016	Sheet : 3 of 37

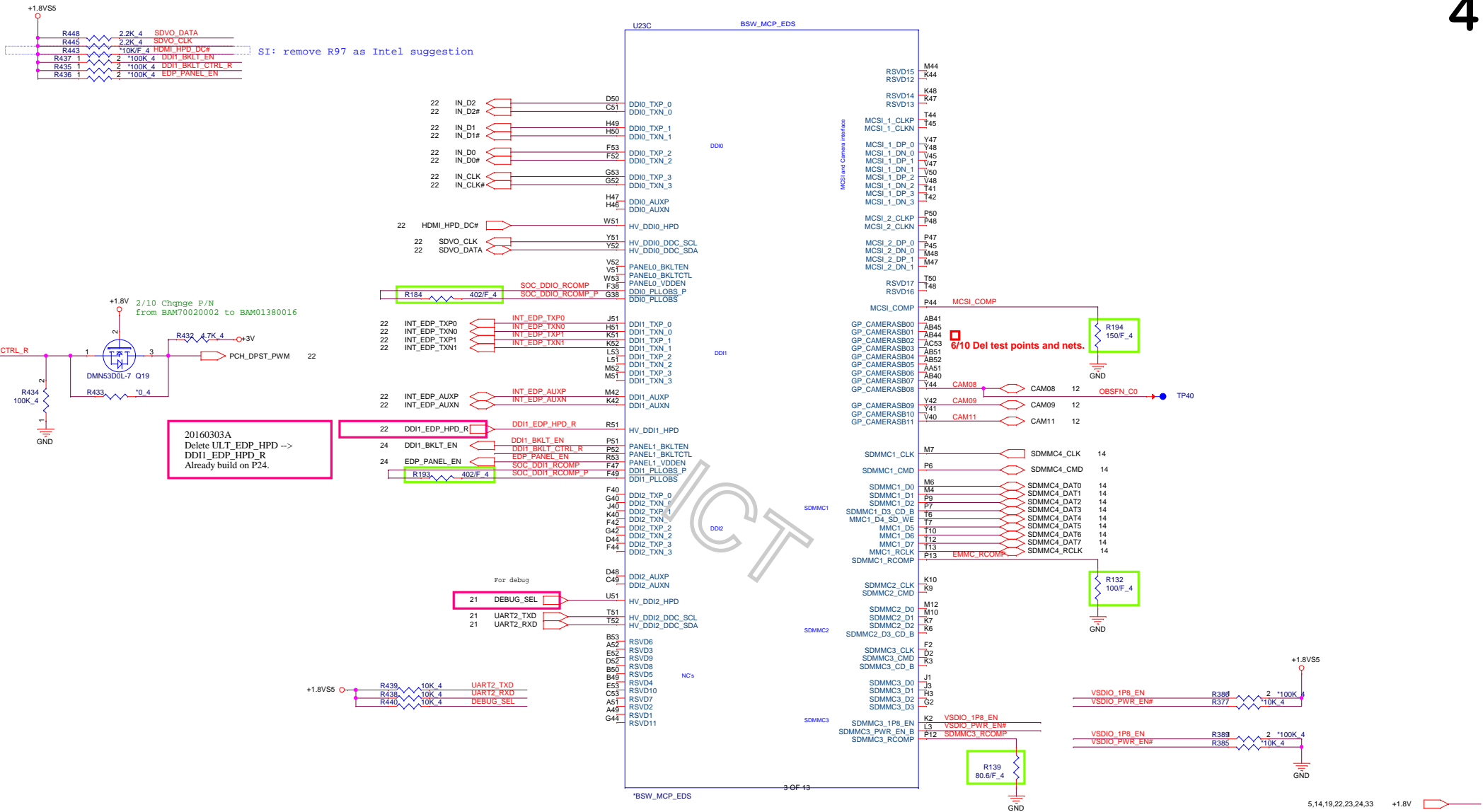

**Quanta Computer Inc.**  
**PROJECT : OP9**

Size	Document Number	Rev.
Custom	Braswell-3 (Display)	1A
Date:	Tuesday, June 07, 2016	Sheet : 4 of 37

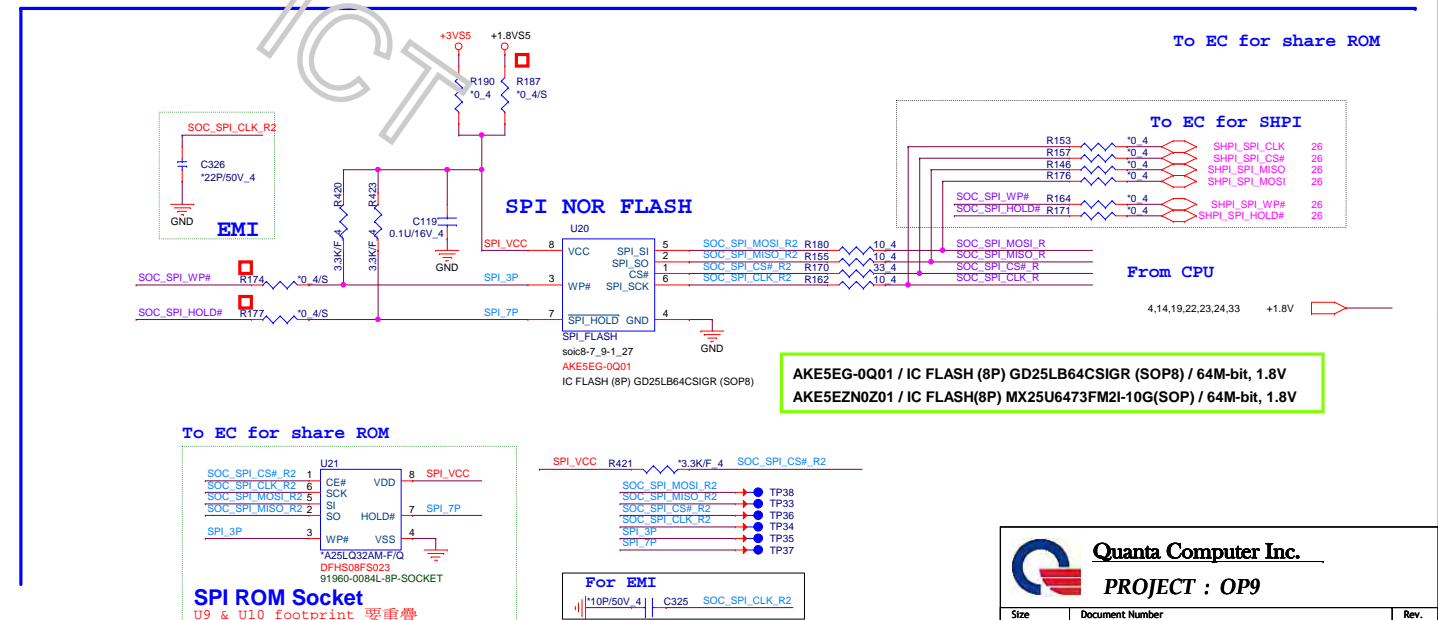
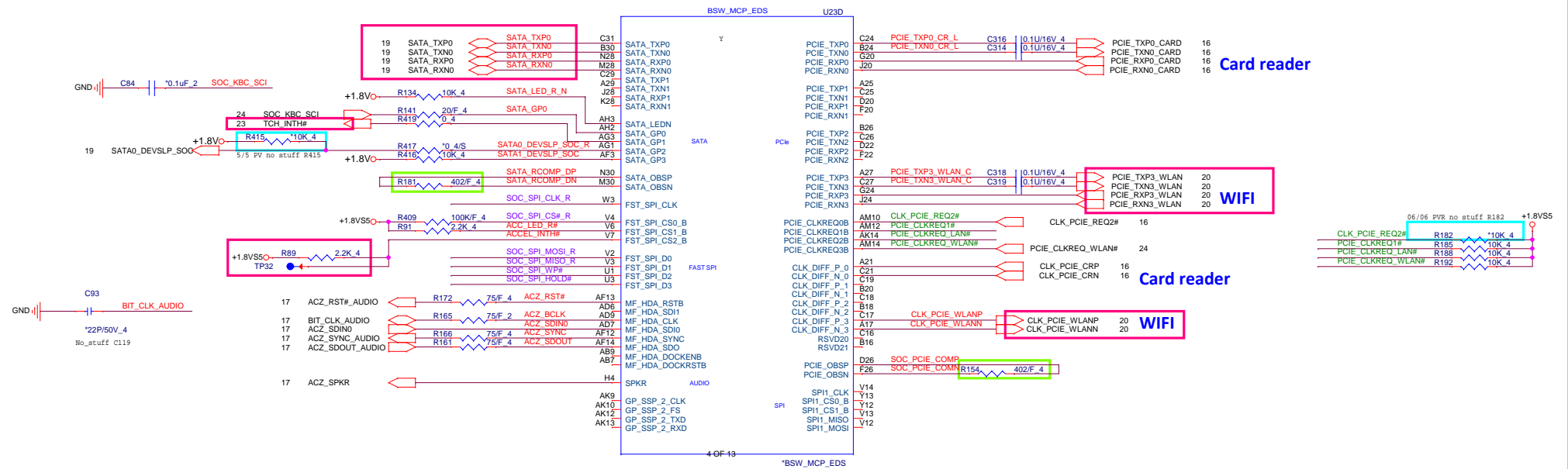

**Quanta Computer Inc.**  
**PROJECT : OP9**

Size Custom	Document Number <b>Braswell-4 (SP/PC/SA/AU)</b>	Rev. 1A
Date: Tuesday, June 07, 2016	Sheet : 5 of 37	

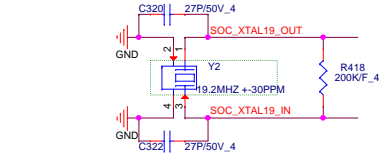

20140109:SI build C68.C69 change for Hosonic suggestion.

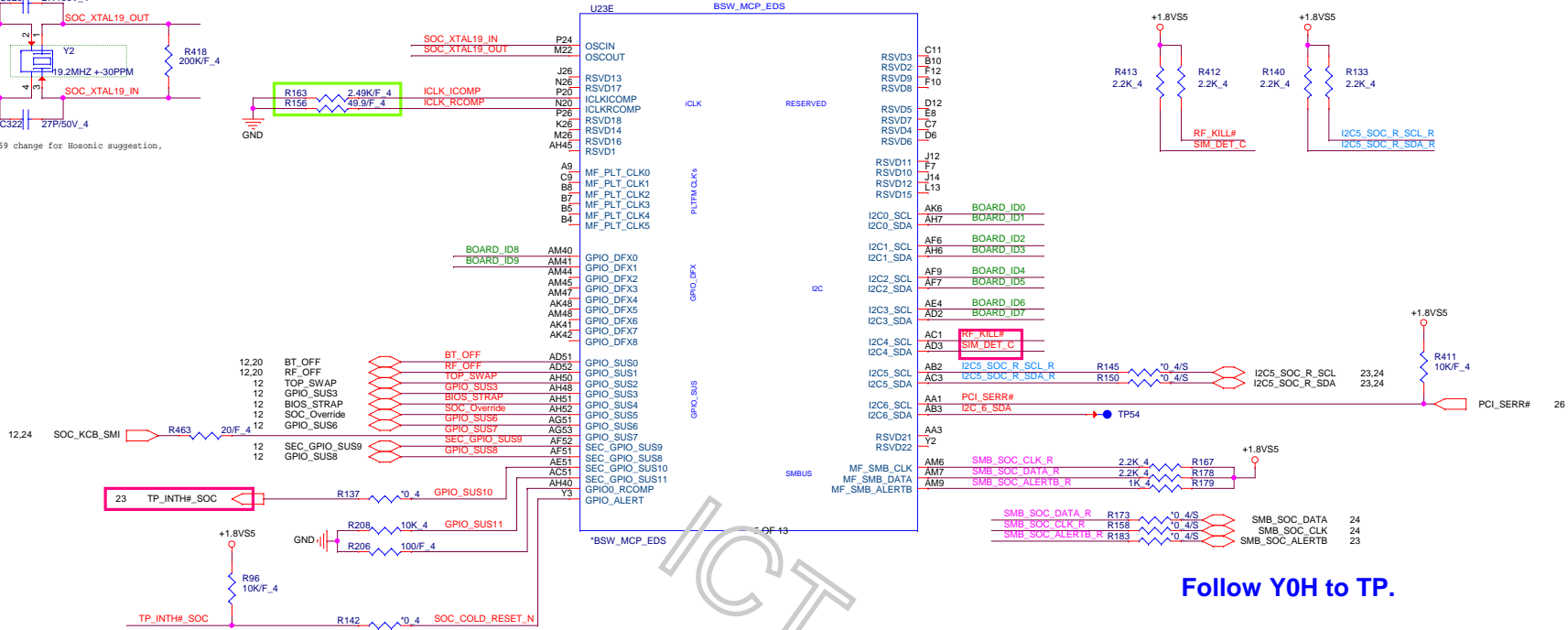

5/4 update Board ID table

Board ID	BIOS Strap Description	BOARD_ID7	BOARD_ID6	BOARD_ID5	Vender	Quanta PN	Description
BOARD_ID0	Reserve	0	0	0	Hymix-2GB	AKD5PGSTW14	IC SDRAM (96P) H5TC4G63CFR-PBA TOPBSQ
BOARD_ID1	Reserve	0	0	1	Micron-2GB		
BOARD_ID2	1 = SSD 0 = EMMC	0	1	0	Samsung-2GB Q.Dye	AKD5JG0T503	C SDRAM(96P)K484G1646E-BYK0(FBGA)TOPBSQ
BOARD_ID8	1 = SO-DIMM 0 = Memory Down <b>Burrito New Add!</b>	1	0	0	Micron-2GB P.Dye	AKD59GSLT04	C SDRAM(96P) MT41K256M16TW-107:P TOPBSQ
BOARD_ID9	1 = touch panel 0 = none touch panel <b>Burrito New Add!</b>	1	1	0			
		1	1	1			

RAM ID	BIOS Strap Description
BOARD_ID3	1 = TPM 0 = none TPM
BOARD_ID4	1 = RAM SIZE: 4G 0 = RAM SIZE: 2G

Need to discuss with BIOS

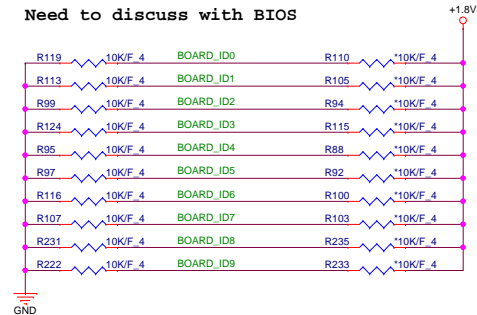

**Quanta Computer Inc.**  
PROJECT : OP9

Size Custom	Document Number <b>Braswell-5 (I2C/ePIO/CLK)</b>	Rev. 1A
Date: Tuesday, June 07, 2016	Sheet : 6 of 37	

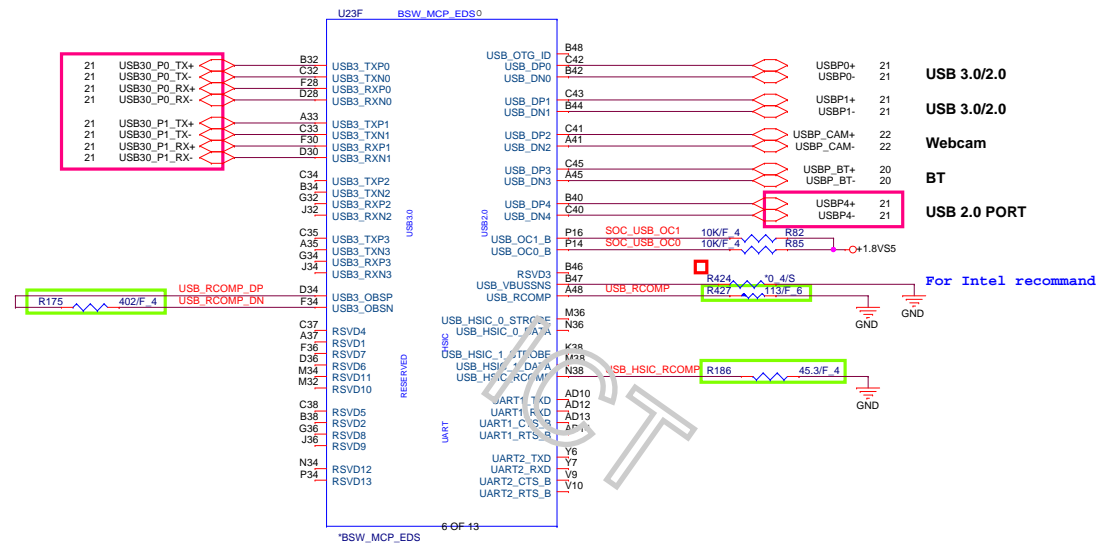

### RTC Clock 32.768KHz

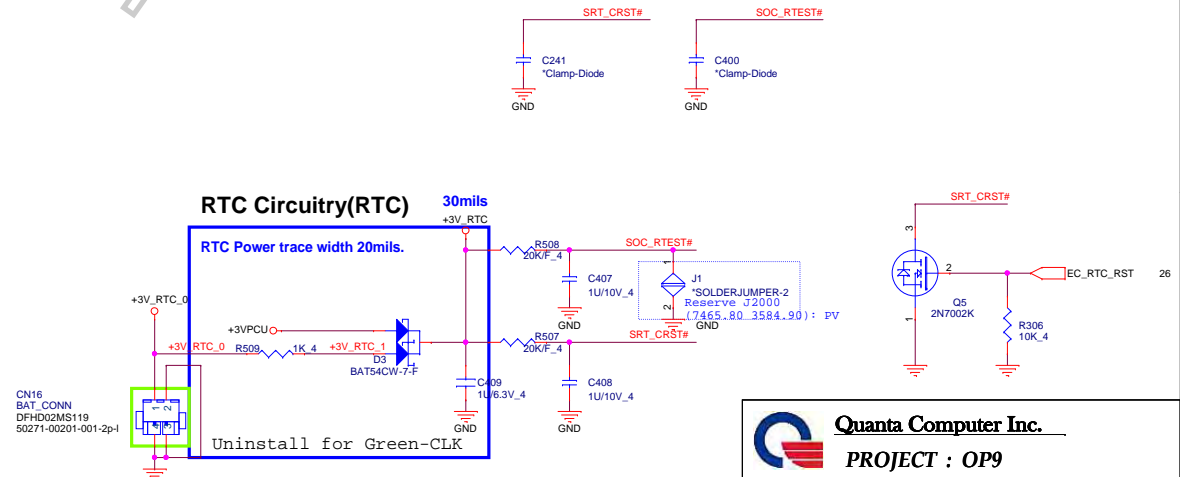
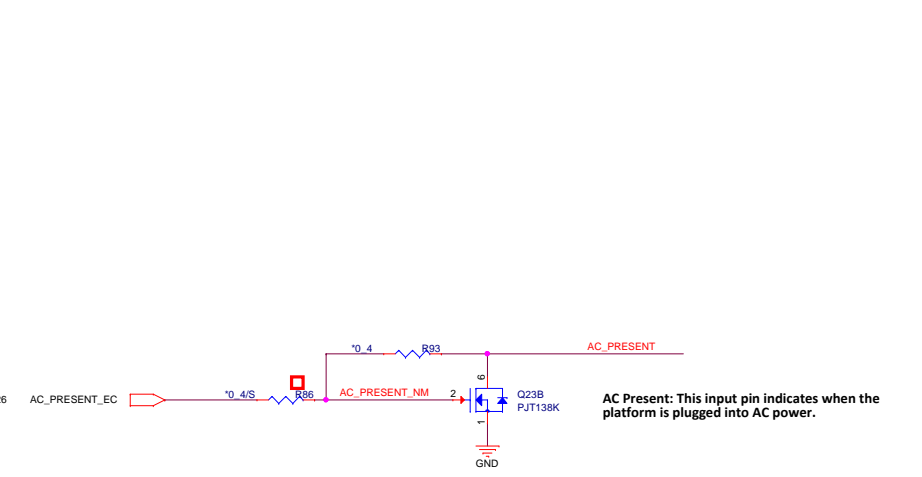
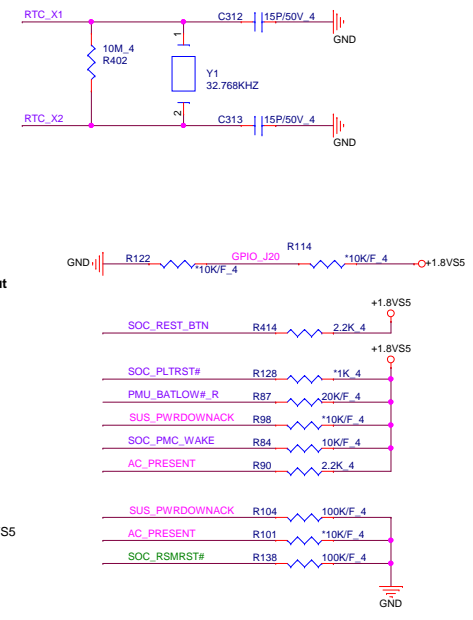
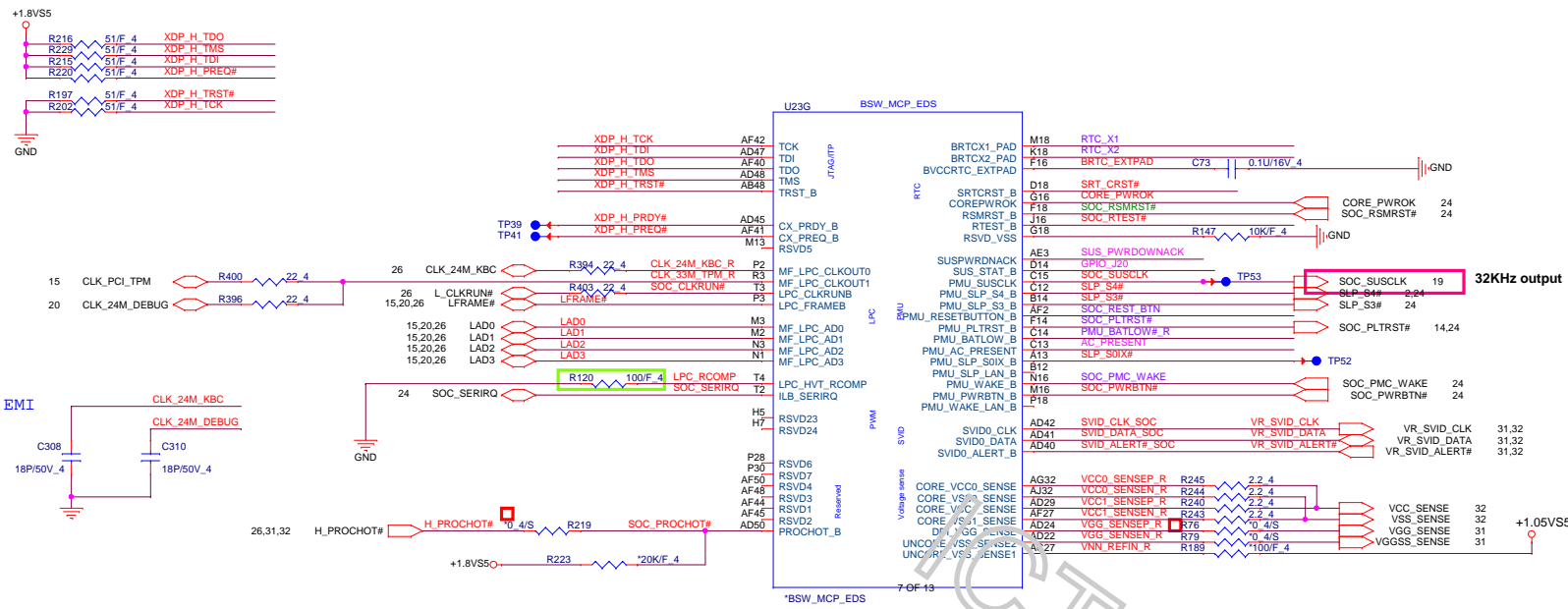

**Quanta Computer Inc.**  
**PROJECT : OP9**

Size Custom	Document Number <b>Braswell-7 (RTC/LPC/PMU)</b>	Rev. 1A
Date: Tuesday, June 07, 2016	Sheet : 8 of 37	



VNN can optionally be merged with V1P05A if display resolution is 2560 x1600 @ 60Hz or lower.

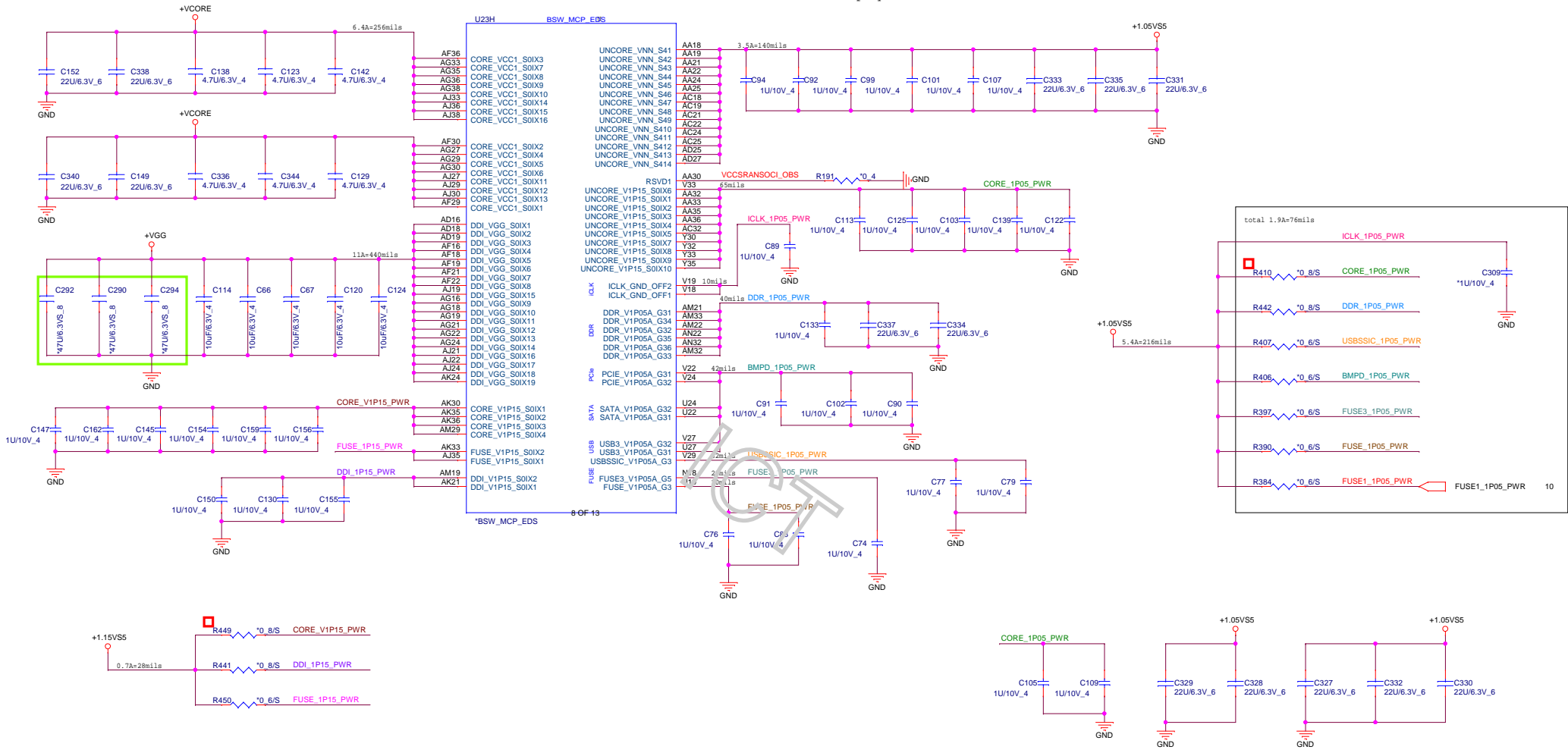

**Quanta Computer Inc.**  
**PROJECT : OP9**

Size	Document Number	Rev.
Custom	Braswell-8 (Power 1)	1A
Date:	Tuesday, June 07, 2016	Sheet : 9 of 37

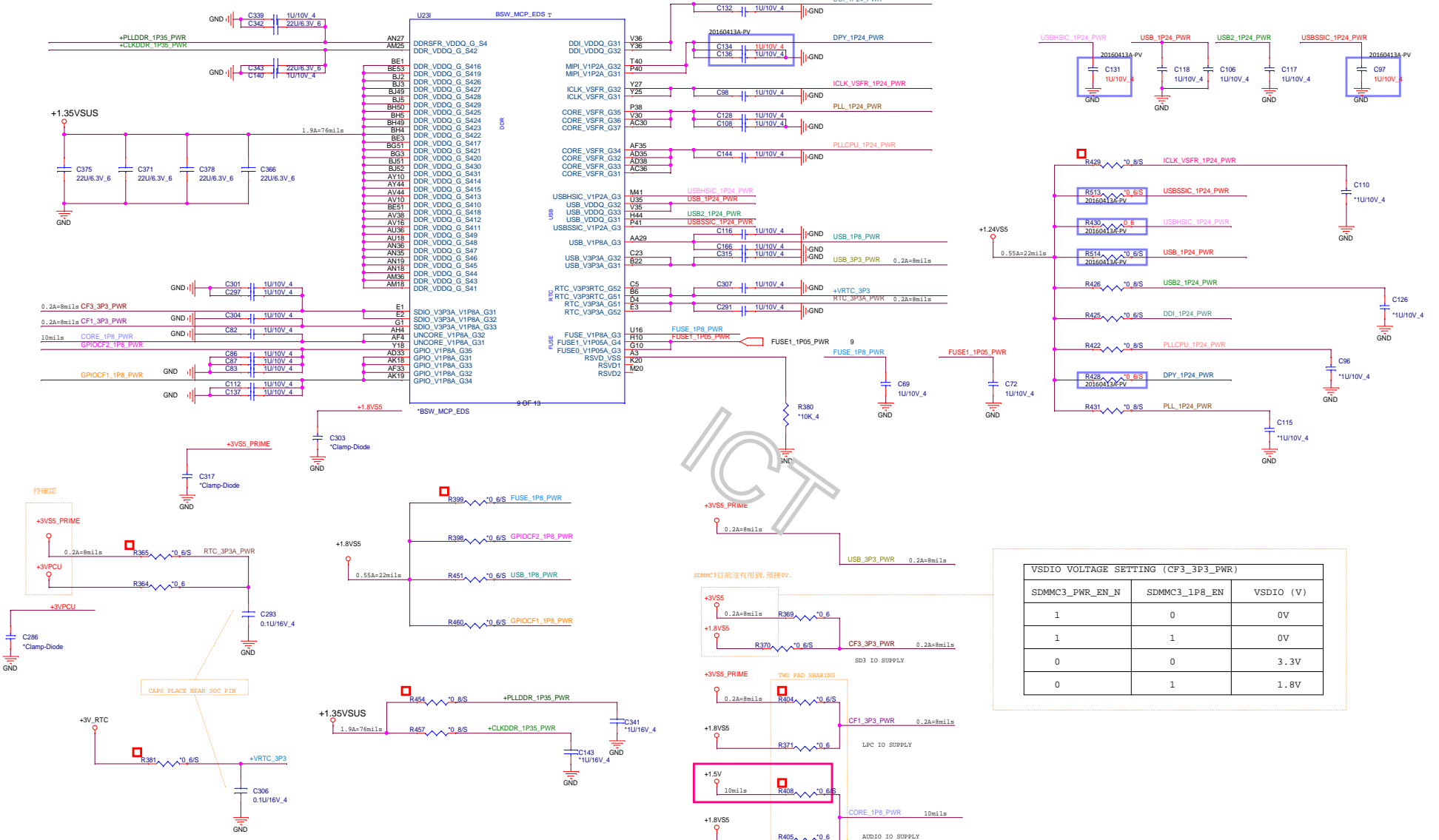

VSDIO VOLTAGE SETTING (CF3\_3P3\_PWR)

SDMMC3_PWR_EN_N	SDMMC3_1P8_EN	VSDIO (V)
1	0	0V
1	1	0V
0	0	3.3V
0	1	1.8V

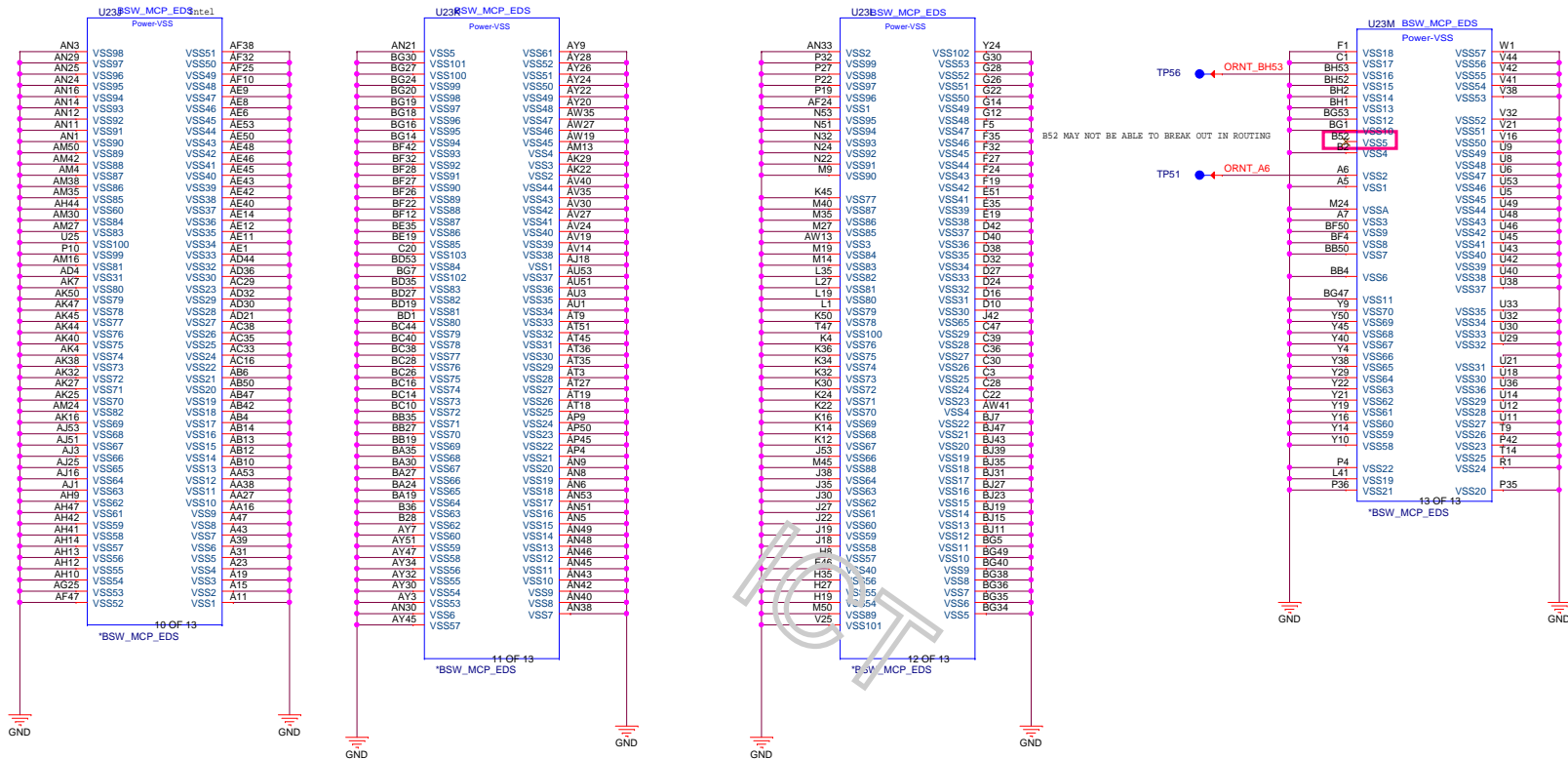

**Quanta Computer Inc.**  
**PROJECT : OP9**

Size Custom	Document Number <b>Braswell-10 (GND)</b>	Rev. 1A
Date: Tuesday, June 07, 2016	Sheet : 11 of 37	

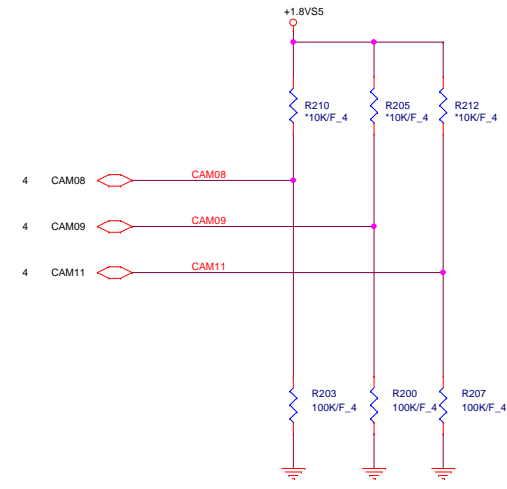
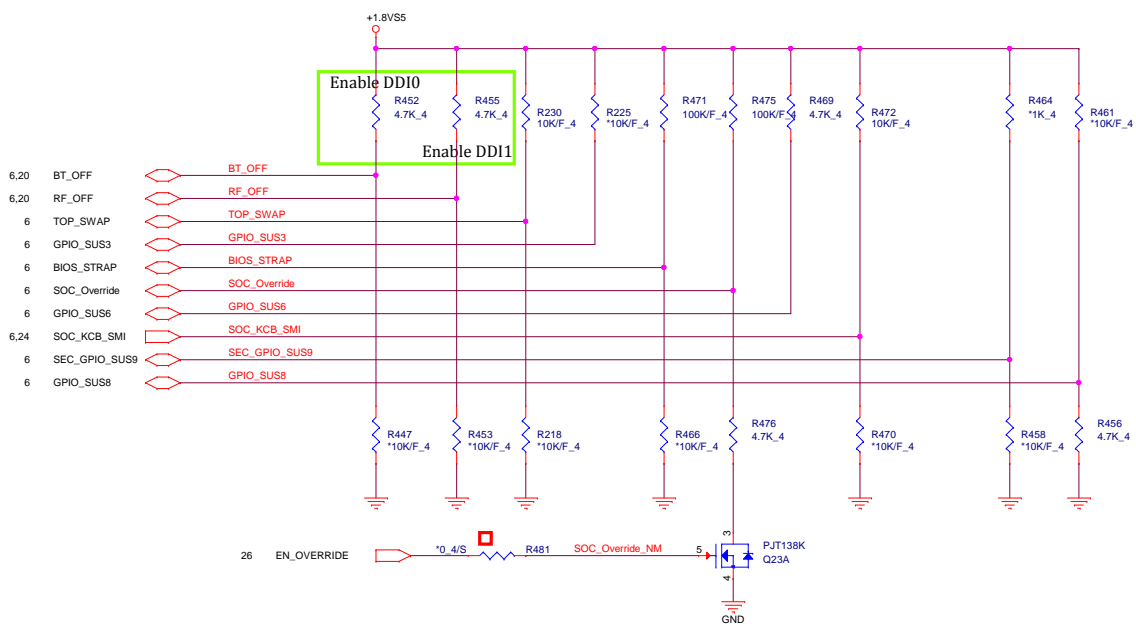

	CAM08	CAM09	CAM11
<b>PULL HIGH</b>	ICLK Xtal OSC Bypass	CCU SUS RO Bypass	RTC OSC Bypass
<b>PULL LOW</b>	ICLK Xtal OSC No Bypass DEFAULT	CCU SUS RO No Bypass DEFAULT	RTC OSC No Bypass DEFAULT

REQUIRED STRAPS

	GPIO_SUS0	GPIO_SUS1	TOP_SWAP	GPIO_SUS3	BIOS_STRAP	SOC_Override	GPIO_SUS6	SOC_KCB_SMI	GPIO_SUS8
<b>PULL HIGH</b>	DDIO detected DEFAULT	DDI1 detected DEFAULT	Normal Operation DEFAULT	Reserve 10 KΩ PU DEFAULT	SPI DEFAULT	Normal Operation	10 KΩ PU to 1.8V DEFAULT	Reserve 10 KΩ PU DEFAULT	Supply is 1.35V
<b>PULL LOW</b>	DDIO not detected	DDI1 not detected	Change Boot Loader address		LPC	Override DEFAULT			Supply is 1.25V DEFAULT

**Quanta Computer Inc.**  
**PROJECT : OP9**

Size Custom	Document Number <b>Braswell-11 (Strap)</b>	Rev. 1A
Date: Tuesday, June 07, 2016	Sheet : 12 of 37	

ICT

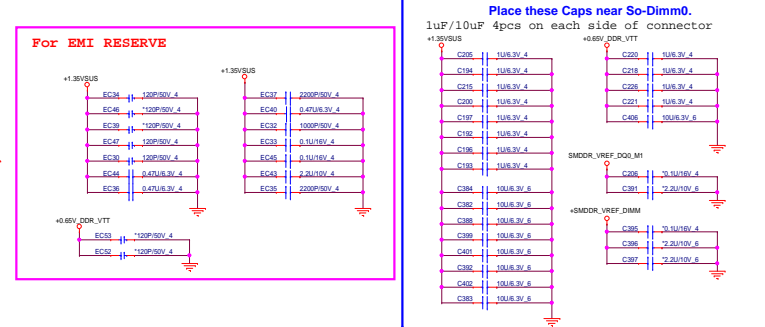
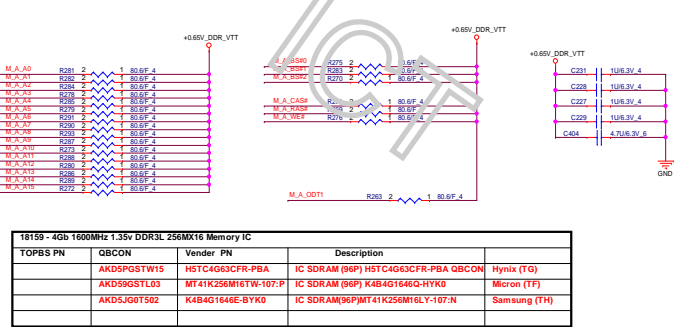
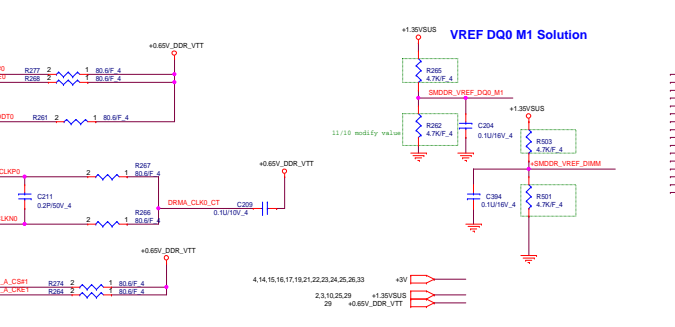
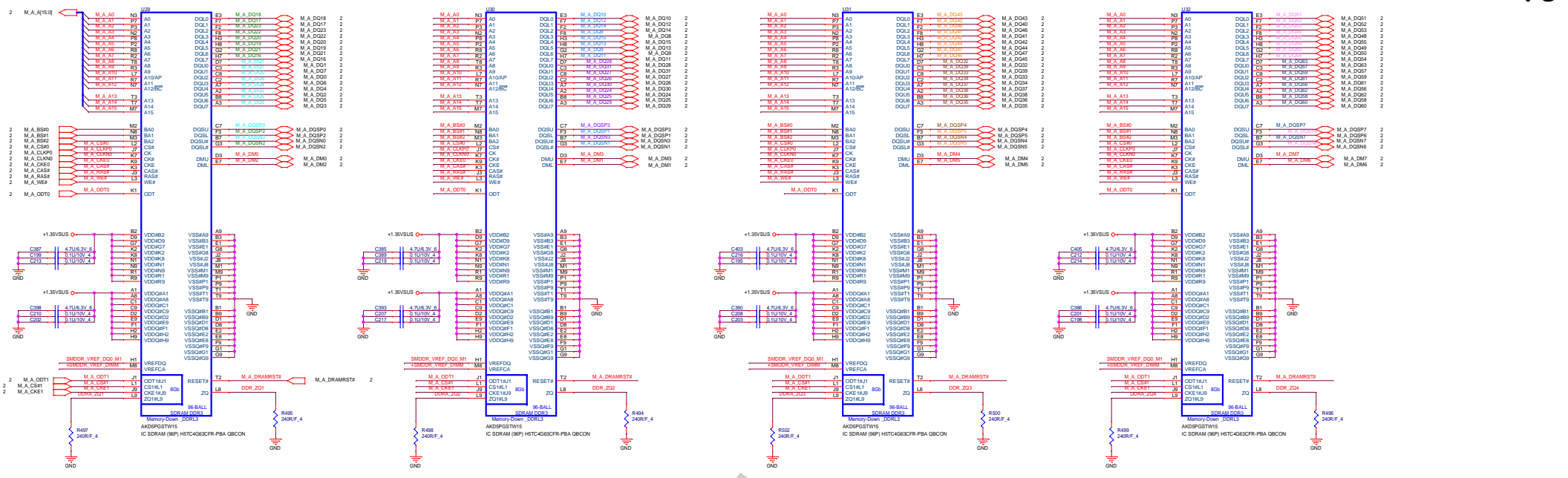

TOPB5 PN	OBCON	Vender PN	Description
AK0SPG0T515	H5TC4G63CFR-PBA	IC SDRAM (96P) H5TC4G63CFR-PBA OBCON	Hynix (TG)
AK0S9G0T3L03	MT41K25M16TW-107:P	IC SDRAM (96P) K4B4G1646E-HYKO	Micron (TF)
AK0SJ00T502	K4B4G1646E-BYK0	IC SDRAM(96P)MT41K256M16LY-107:N	Samsung (TH)

Place these Caps near So-Dimm0.

1uF/10uF 4pcs on each side of connector

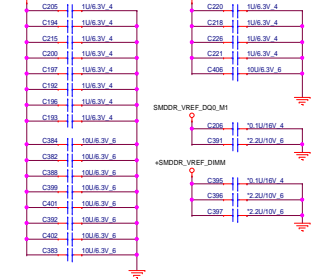

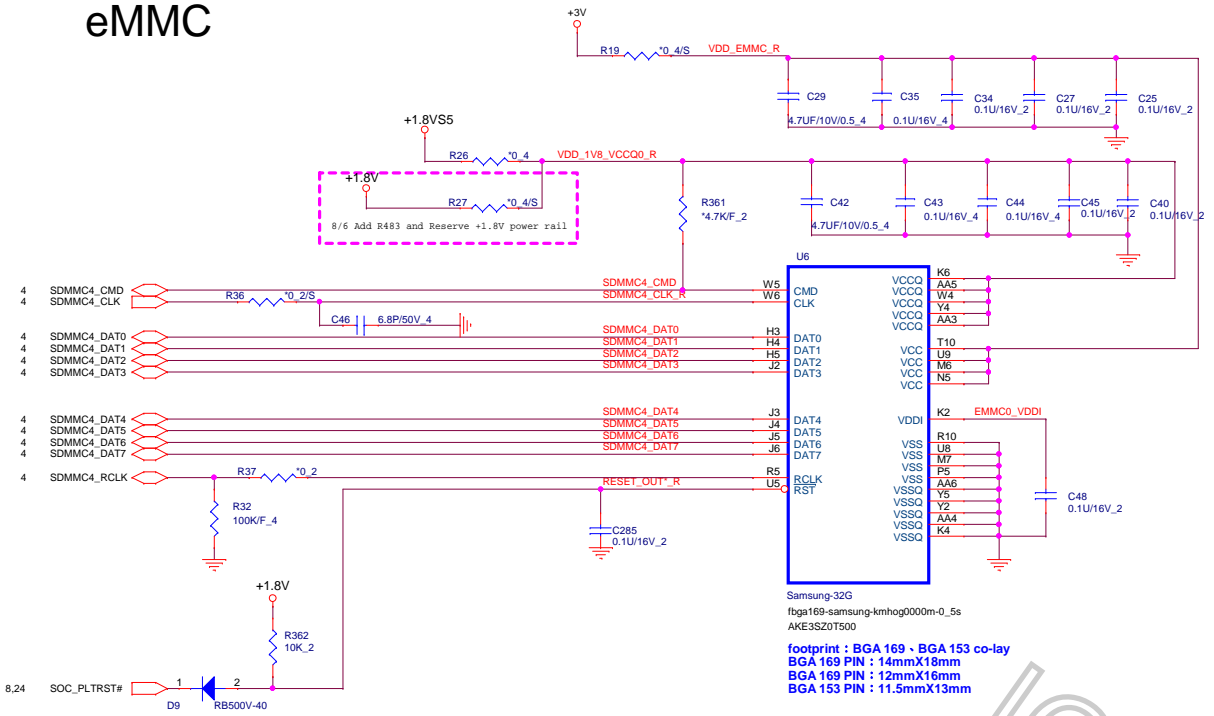

27741 - eMMC 32GB MO-276 MMCv5.0

TOPBSQ	QBCON	Description	SIZE	Vender
	AKE3SZ0T500	IC FLASH(153P) KLMBG2JENB-B041 QBCON	32G	Samsung
	AKE3SF-T106	IC FLASH(153P) SDINADF4-32G-H QBCON	32G	SanDisk

eMMC setting		Location				
Vender	SIZE	R168	R169	R160	R159	R152
Hynix	32G	1	0	0	0	0
samaung	32G	1	1	0	0	0
SanDisk	32G	1	1	1	0	0
Hynix	64G	1	1	1	1	0
samaung	64G	0	1	1	1	1
SanDisk	64G	0	0	1	1	1
Hynix (new)	32G	0	0	0	1	1
Hynix (new)	64G	0	0	0	0	1
		0	0	0	0	0
HDD		1	1	1	1	1

Memory setting		Location				
Vender	SIZE	R151	R144	R143	R136	R135
Hynix	2G	1	0	0	0	0
samaung	2G	1	1	0	0	0
Micron	2G	1	1	1	0	0
Hynix	4G	1	1	1	1	0
samaung	4G	0	1	1	1	1
Micron	4G	0	0	1	1	1
samaung E	2G	0	0	0	1	1
Micron P	2G	0	0	0	0	1
		0	0	0	0	0
		1	1	1	1	1

**Quanta Computer Inc.**  
PROJECT : OP9

Size Custom	Document Number Storage eMMC	Rev. 1A
Date: Tuesday, June 07, 2016	Sheet : 14 of 37	

# Accelerometer Sensor

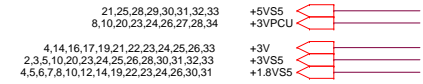

# TPM (2.0)

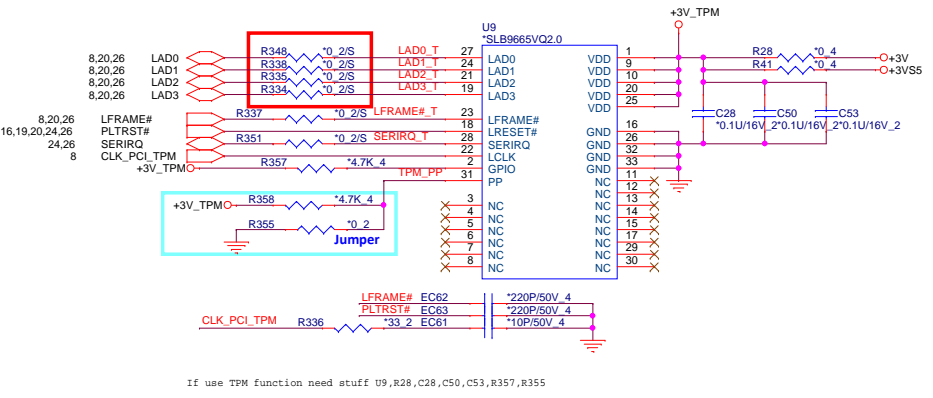

# Touch screen

# Green CLK Circuitry



CardReader

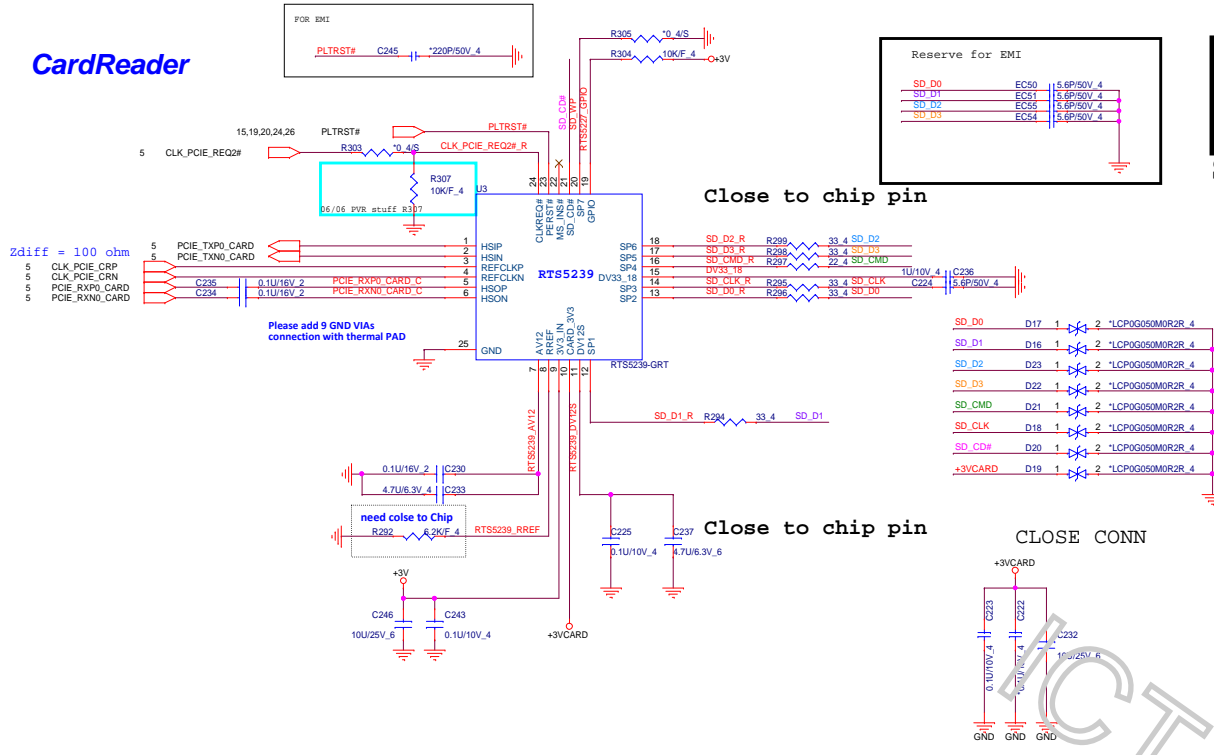

Share Pin

SP1	SD_D1	MS_D1
SP2	SD_D0	MS_D0
SP3	SD_CLK	MS_D0
SP4	SD_CMD	MS_D2
SP5	SD_D3	MS_D3
SP6	SD_D2	MS_CLK
SP7	SD_WP	MS_BS

SD CARD READER  
(CD : Normal open)

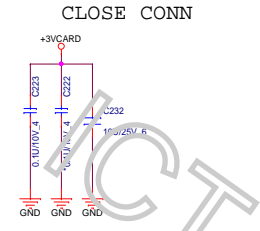
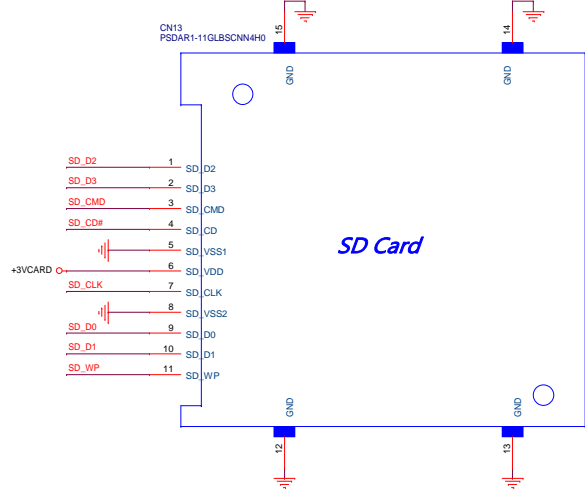



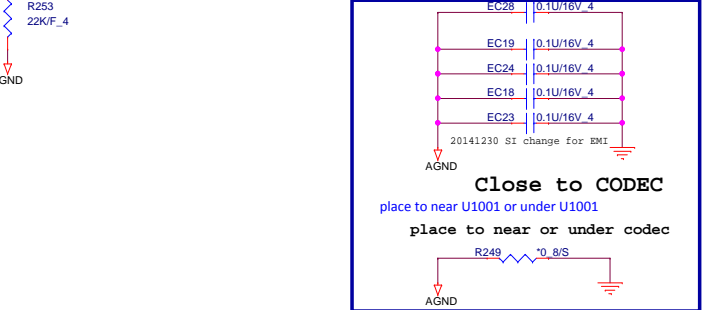
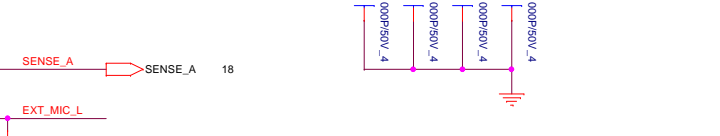
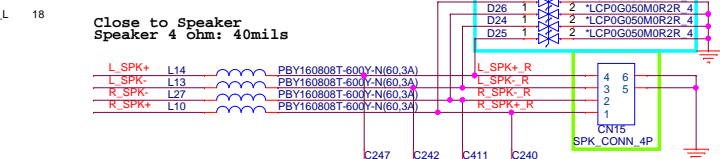
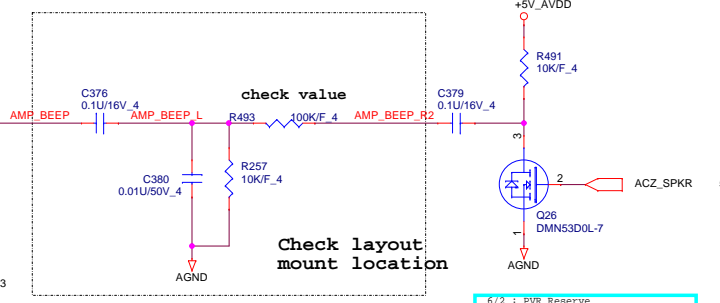
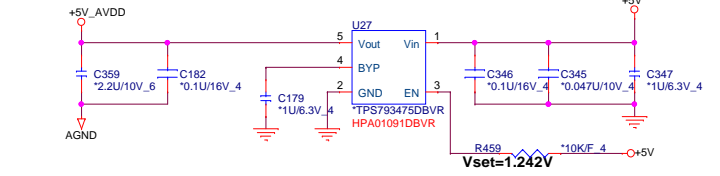
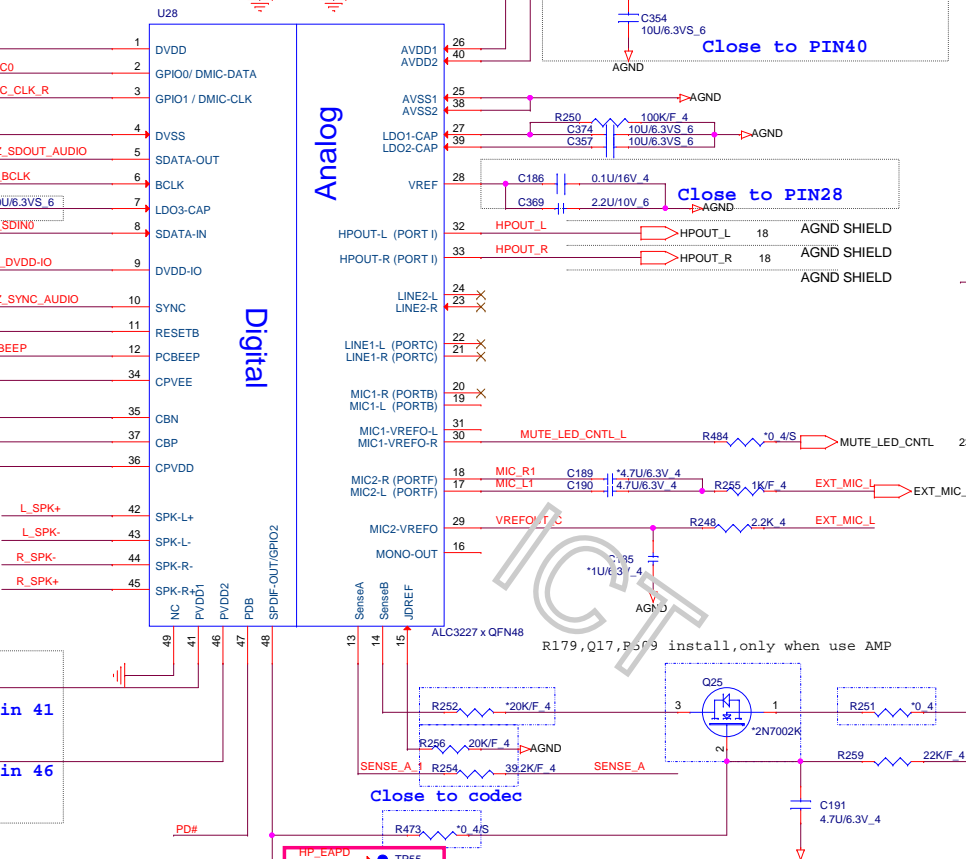
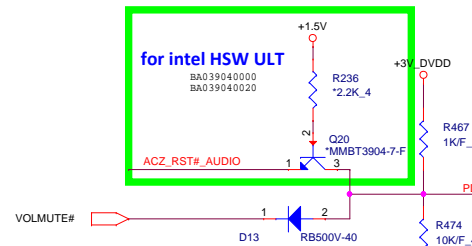
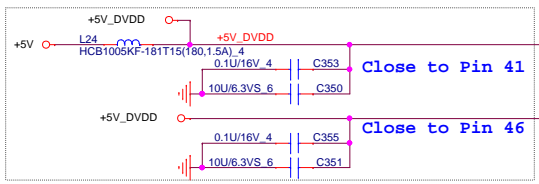
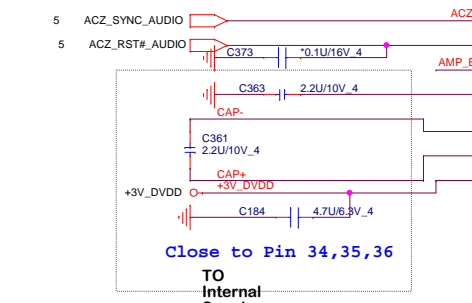
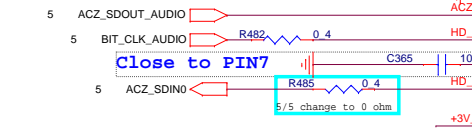
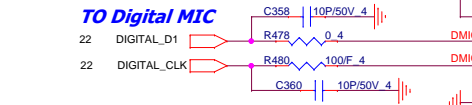
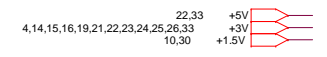
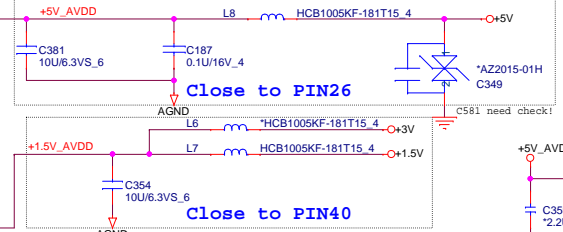
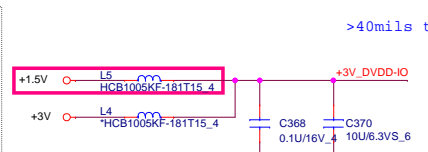
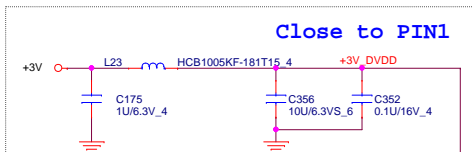

R179, Q17, B579 install, only when use AMP

R1070 install, only when remove AMP

**Quanta Computer Inc.**  
**PROJECT : OP9**

Size	Document Number	Rev.
Custom	Audio Realtek 3227	1A
Date:	Tuesday, June 07, 2016	Sheet : 17 of 37

Head Phone out

4,14,15,16,17,19,21,22,23,24,25,26,33 17,22,33 +5V  
+3V

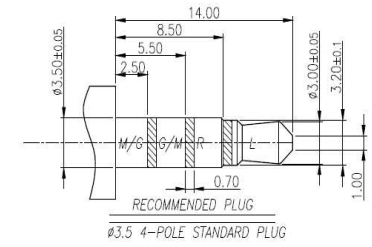
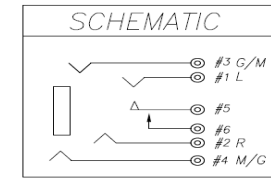
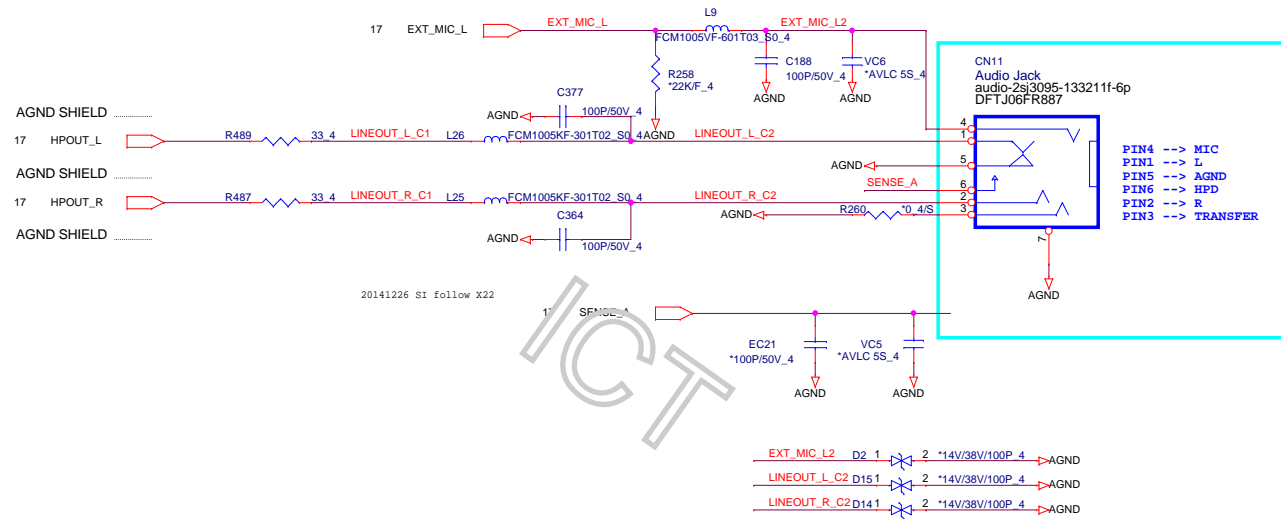

- EXT\_MIC\_L2 D2 1 2 \*14V/38V/100P\_4 -> AGND
- LINEOUT\_L\_C2 D15 1 2 \*14V/38V/100P\_4 -> AGND
- LINEOUT\_R\_C2 D14 1 2 \*14V/38V/100P\_4 -> AGND

		<b>Quanta Computer Inc.</b>	
		<b>PROJECT : OP9</b>	
Size Custom	Document Number <b>HEADPHONE</b>	Rev. 1A	
Date: Tuesday, June 07, 2016	Sheet : 18 of 37		

CONN: M KEY  
MODULE: N/A

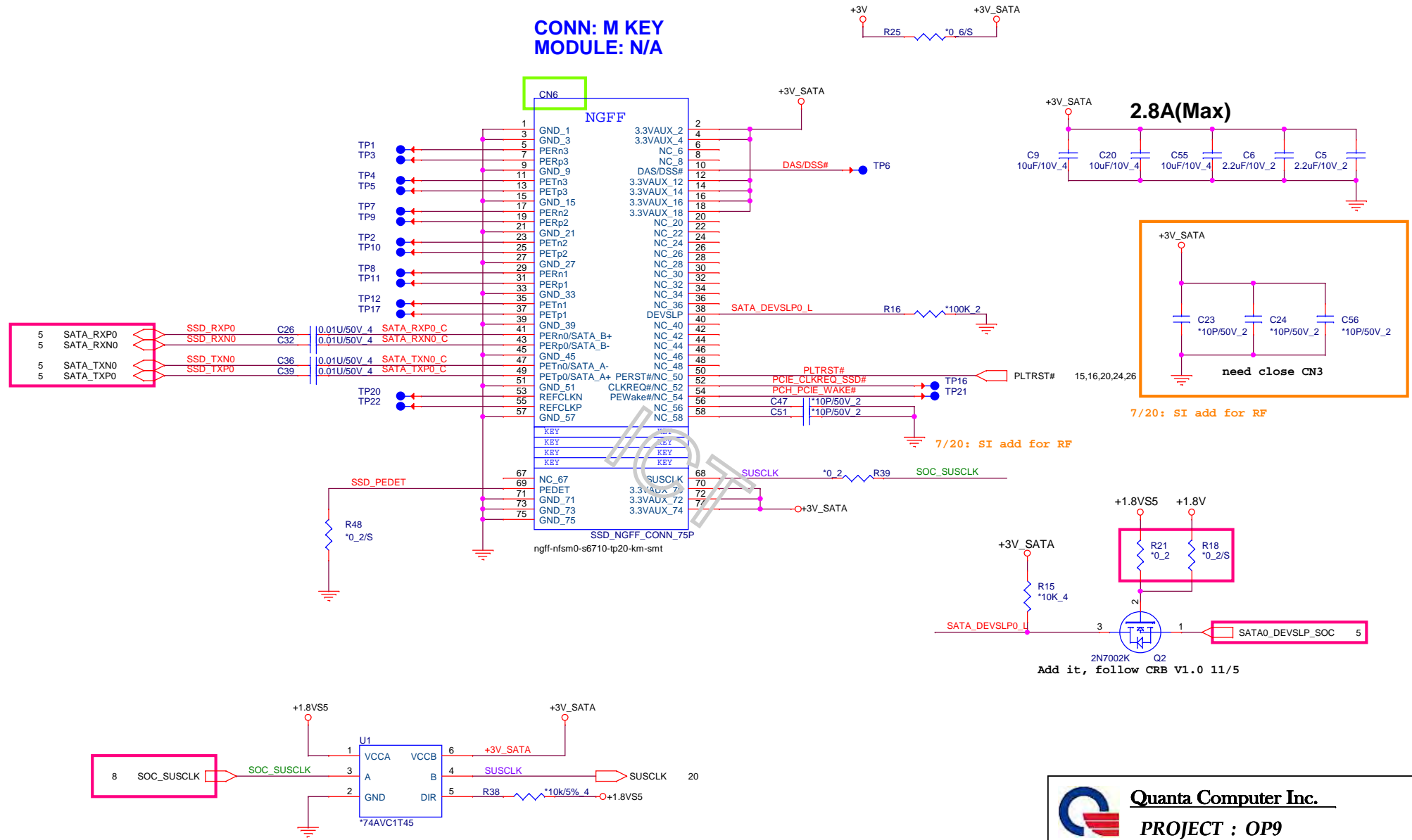

**Quanta Computer Inc.**  
**PROJECT : OP9**

Size B	Document Number <b>SSD (NGFF)</b>	Rev. 1A
Date: Tuesday, June 07, 2016	Sheet : 19 of 37	

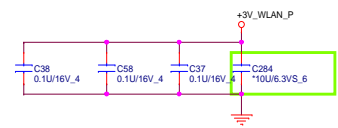
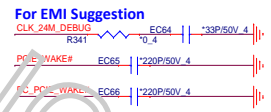
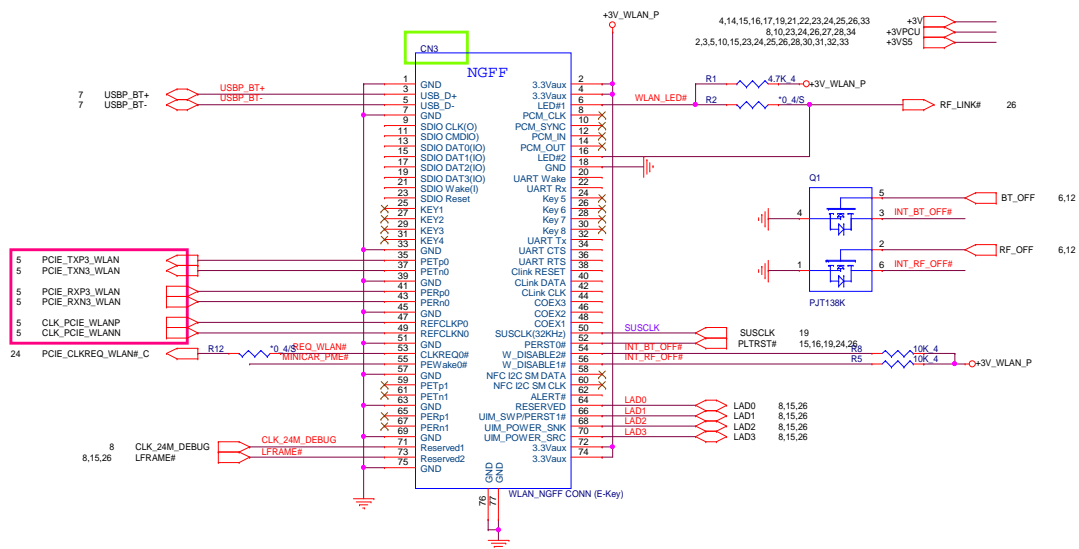
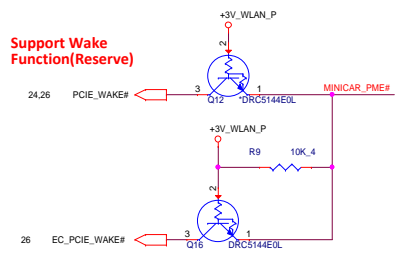
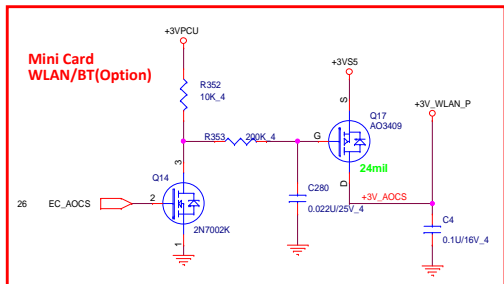

### USB 2.0/3.0 Combo PORT1

20141223: SI build  
Stuff VC2 for BSD

+3V 4,14,15,16,17,19,22,23,24,25,26,33  
+3VPCU 8,10,20,23,24,26,27,28,34  
+5VSS 25,26,29,30,31,32,33

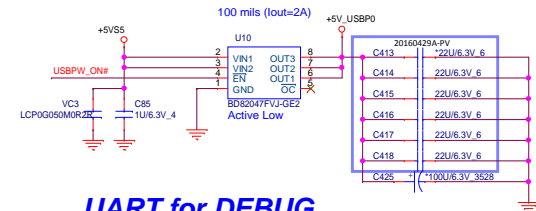

### UART for DEBUG

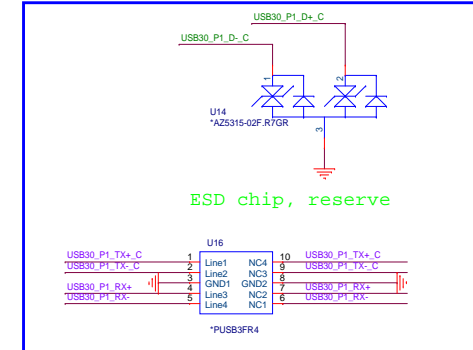
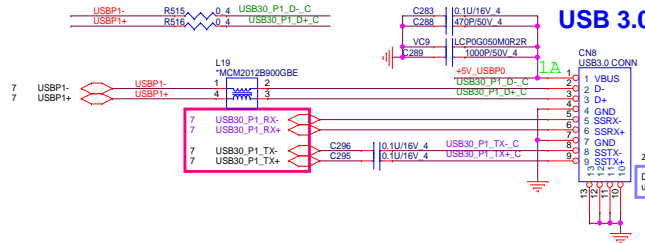
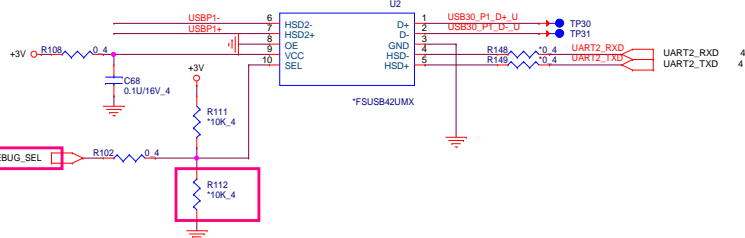

### USB 2.0/3.0 Combo PORT0

20141223: SI build  
Stuff VC2 for BSD

USBP0- R517 0.4 USB30\_P0\_D- C  
USBP0+ R516 0.4 USB30\_P0\_D+ C

+3V 4,14,15,16,17,19,22,23,24,25,26,33  
+3VPCU 8,10,20,23,24,26,27,28,34  
+5VSS 25,26,29,30,31,32,33

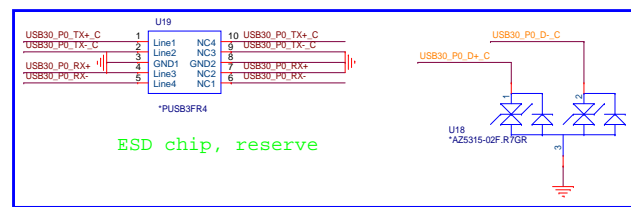
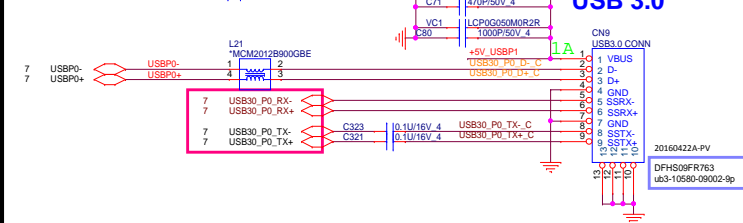

### USB 2.0 Only

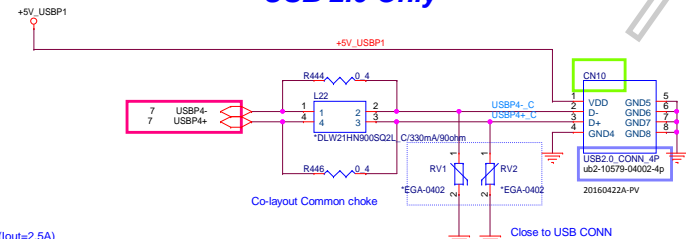

### USB POWER SWITCH

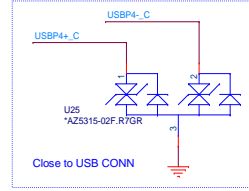
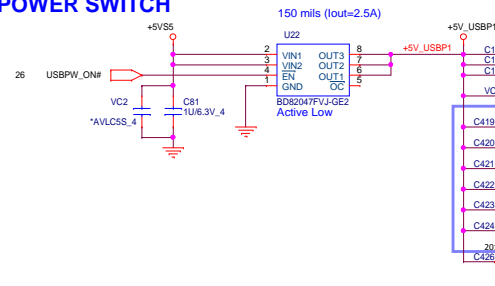

# LID Switch

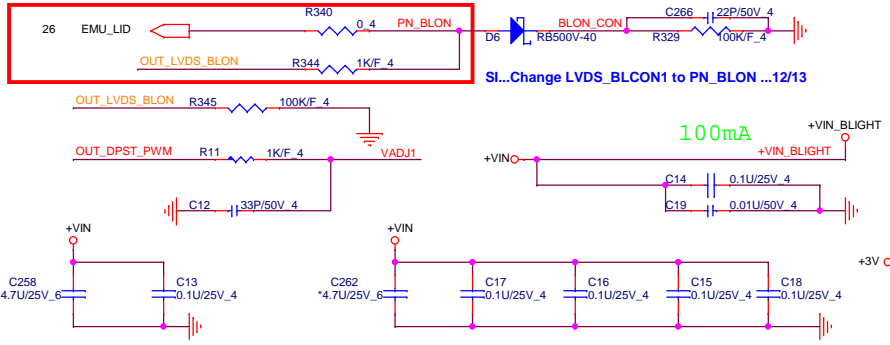

R250 can't change to shortpad

Sl...Change LVDS\_BLCON1 to PN\_BLON ...12/13

100mA

4,14,15,16,17,19,21,23,24,25,26,33  
4.5,14,19,23,24,33  
4.5,6,7,8,10,12,14,19,23,24,26,30,31  
25,27,28,29,31,32  
17,33

+3V  
+1.8V  
+1.8VSS  
+VIN  
+5V

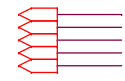

**22**  
**LVDS Conn.**  
GS12401-1011-9H  
51519-0300t-v01-30p-l

RT2136 output high  
SOC active Low

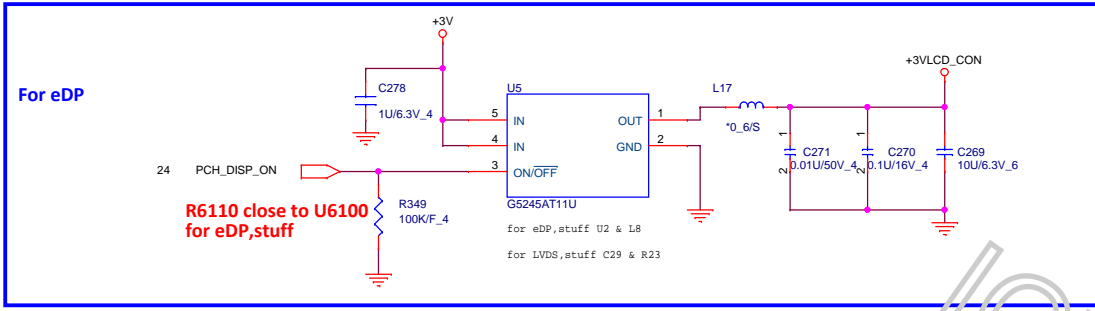
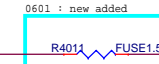
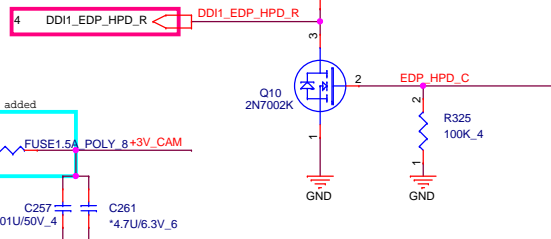

For eDP

R6110 close to U6100  
for eDP,stuff

for eDP,stuff U2 & L8  
for LVDS,stuff C29 & R23

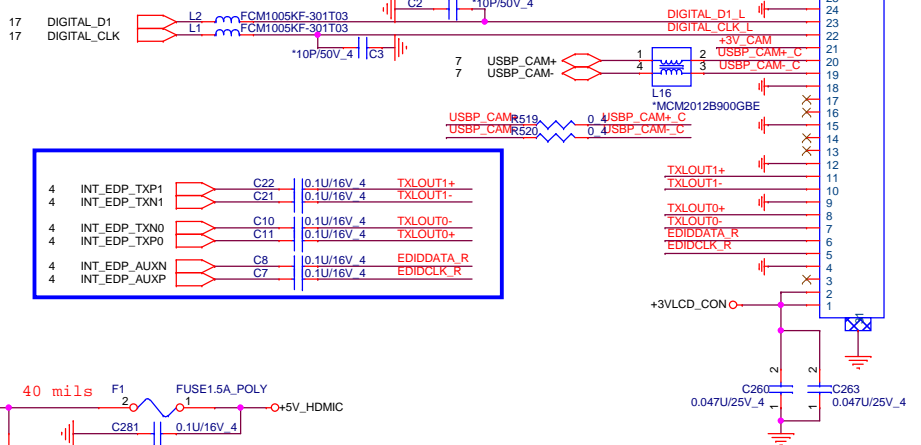

## HDMI SMBus isolation

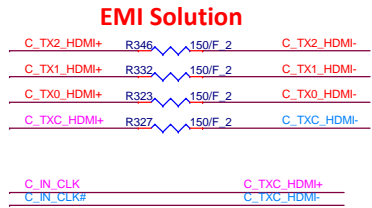

## Close to HDMI connector

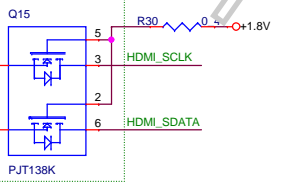
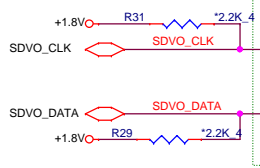

## Close to HDMI connector

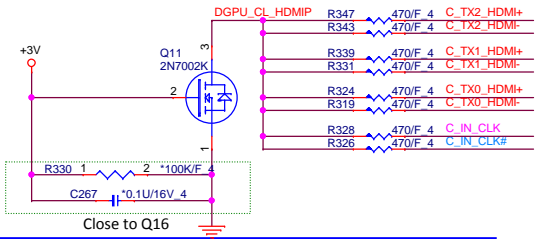

Close to Q16

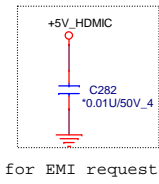
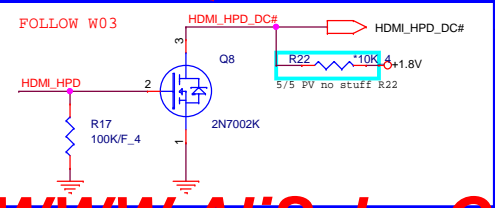

for EMI request

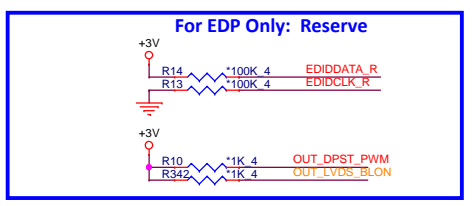
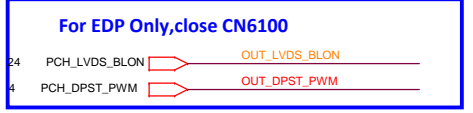
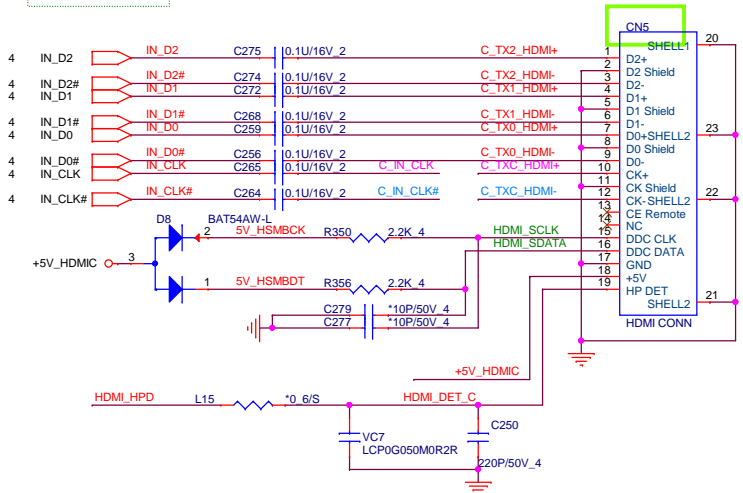

**Quanta Computer Inc.**  
**PROJECT : OP9**

Size	Document Number	Rev.
Custom	LCD CONN/LID/CAM/D-MIC	1A
Date:	Tuesday, June 07, 2016	Sheet : 22 of 37

For EMI Suggestion

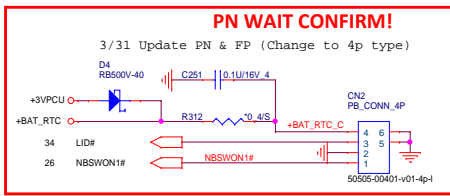
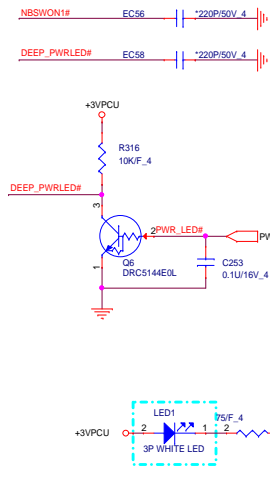

Touch Pad Connector

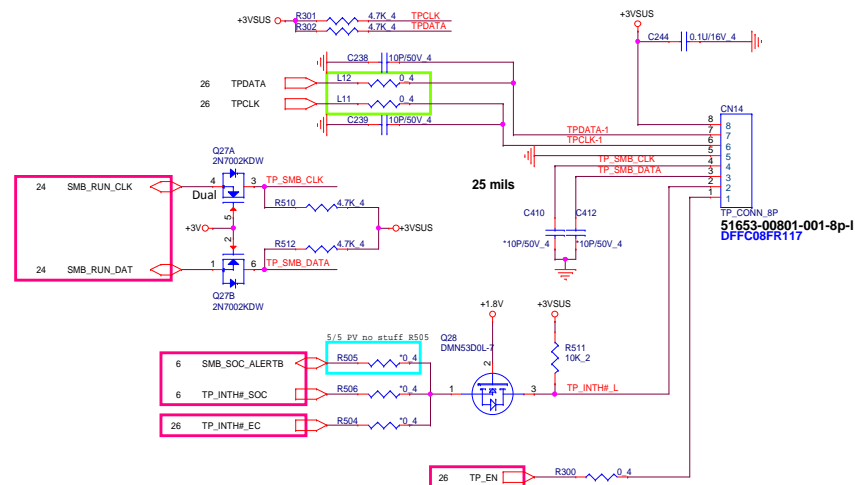

KEYBOARD Con.

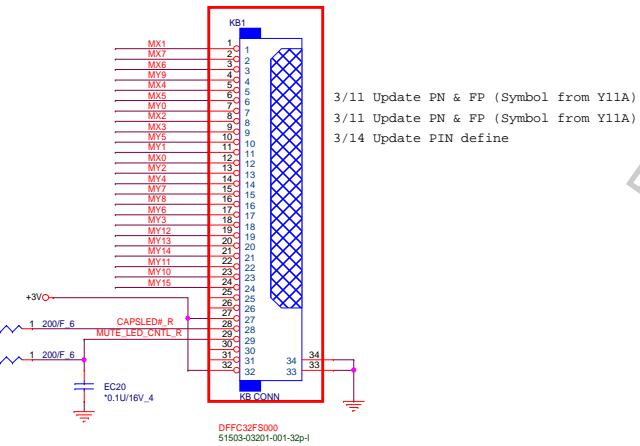
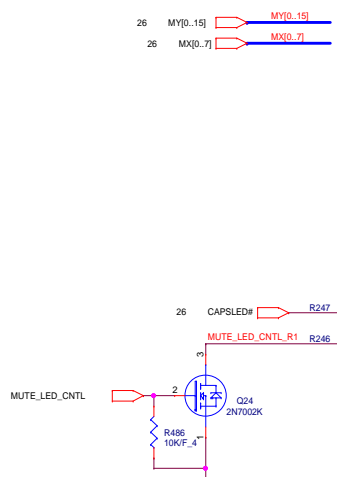

KEYBOARD PULL-UP

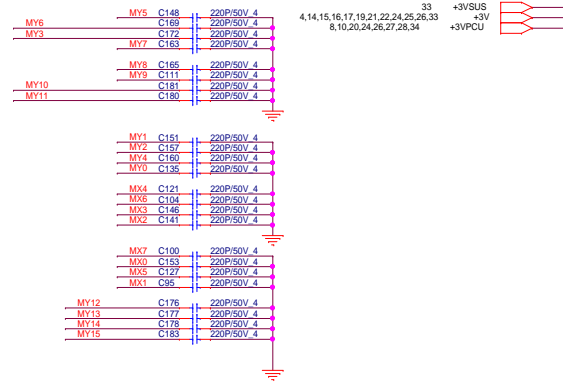
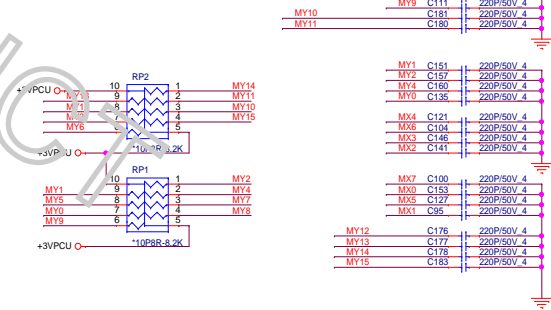

Touch Screen CN.

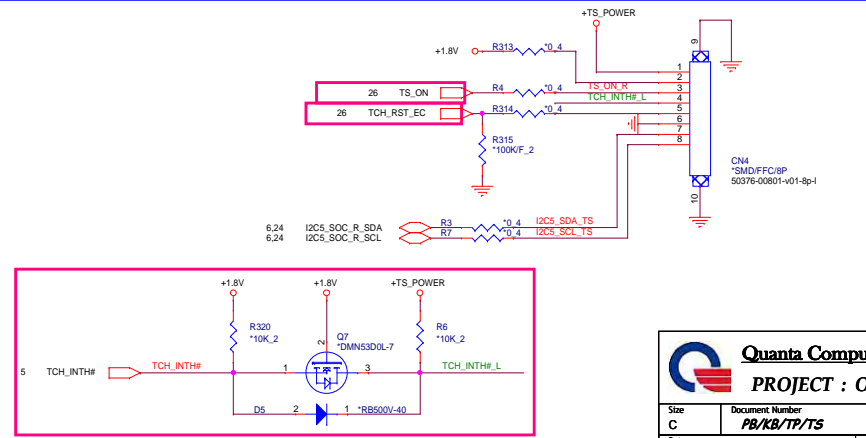
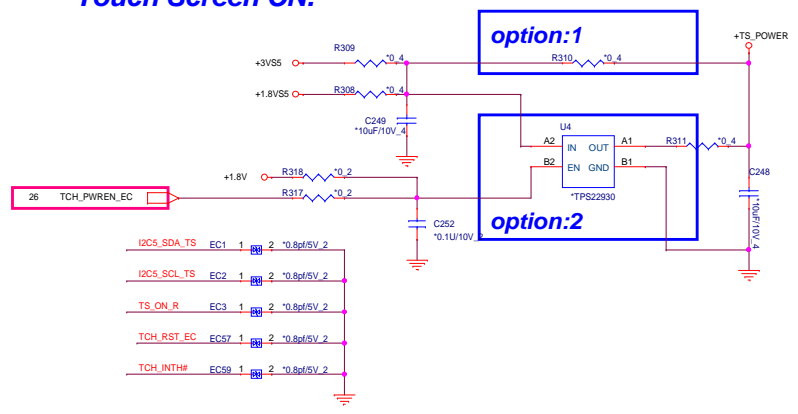

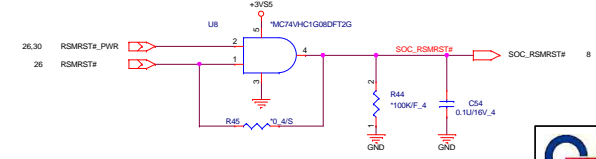
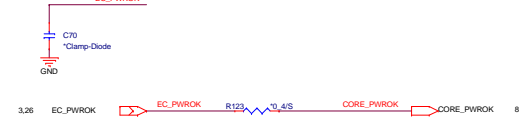
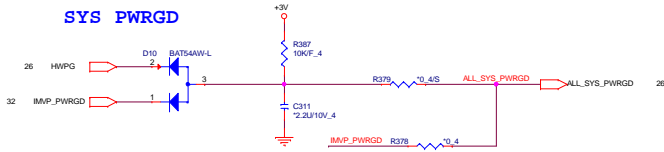
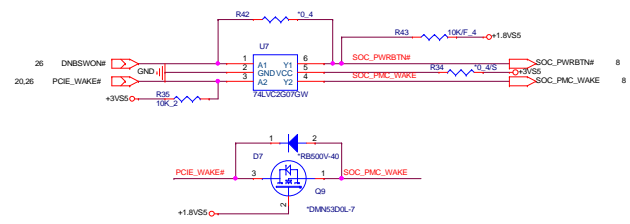
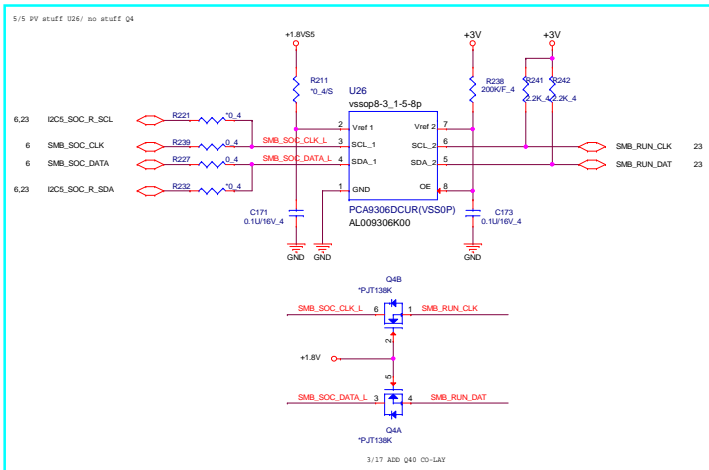
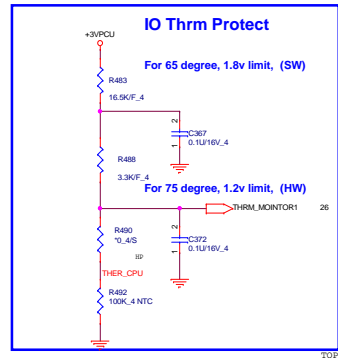
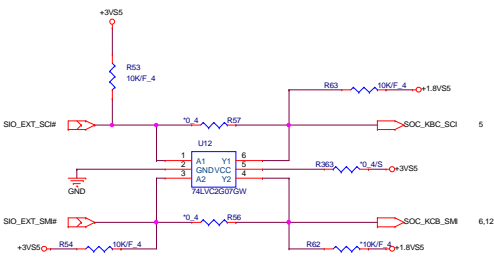
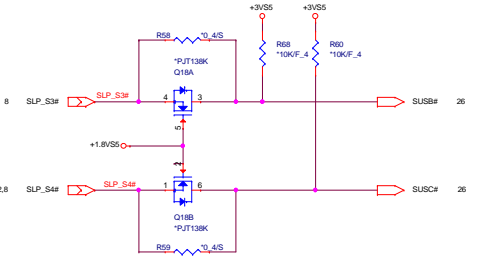
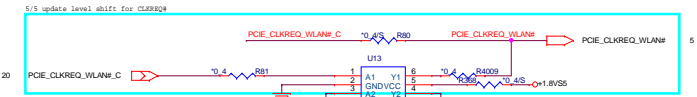
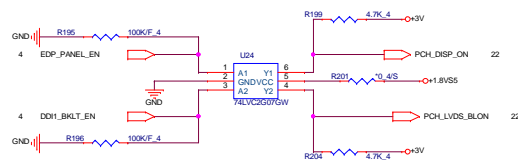
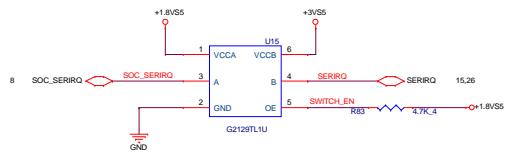

**Quanta Computer Inc.**  
**PROJECT : OP9**

Size	Document Number	Rev.
Custom	Level shift/Thermistor	1A
Date:	Tuesday, June 07, 2016	Sheet : 24 of 37

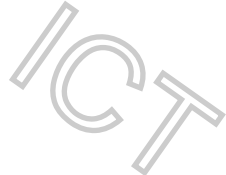



EMI Reserve

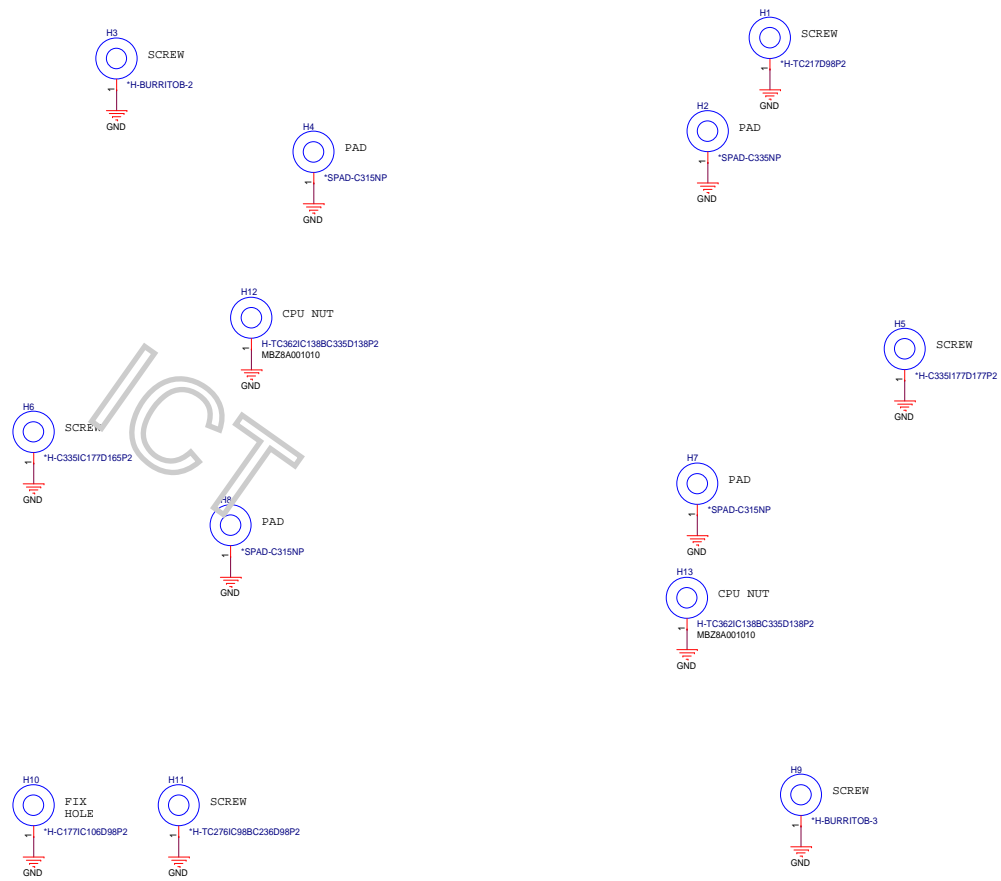
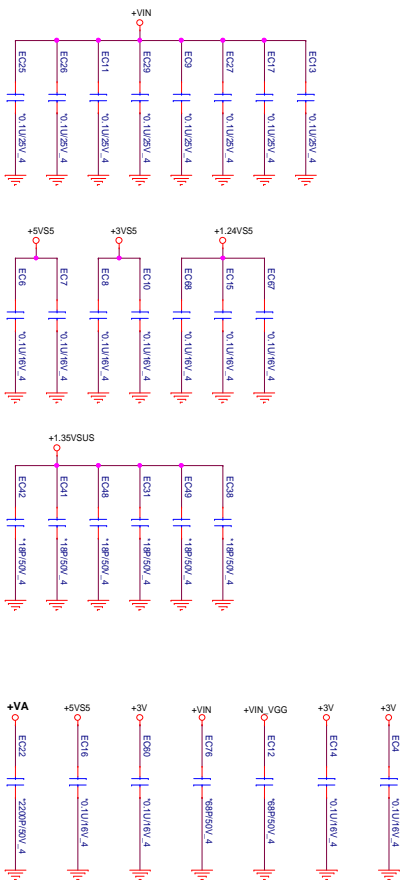

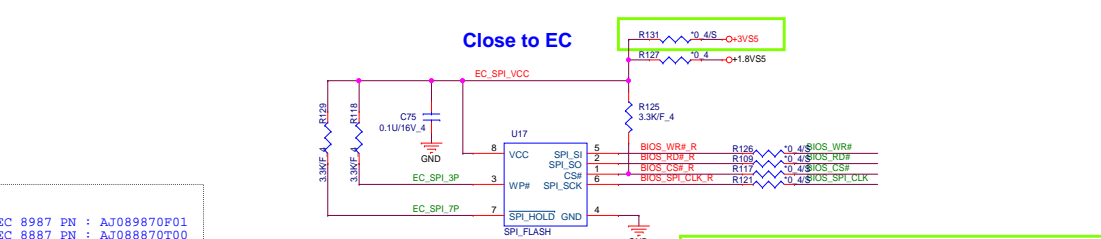
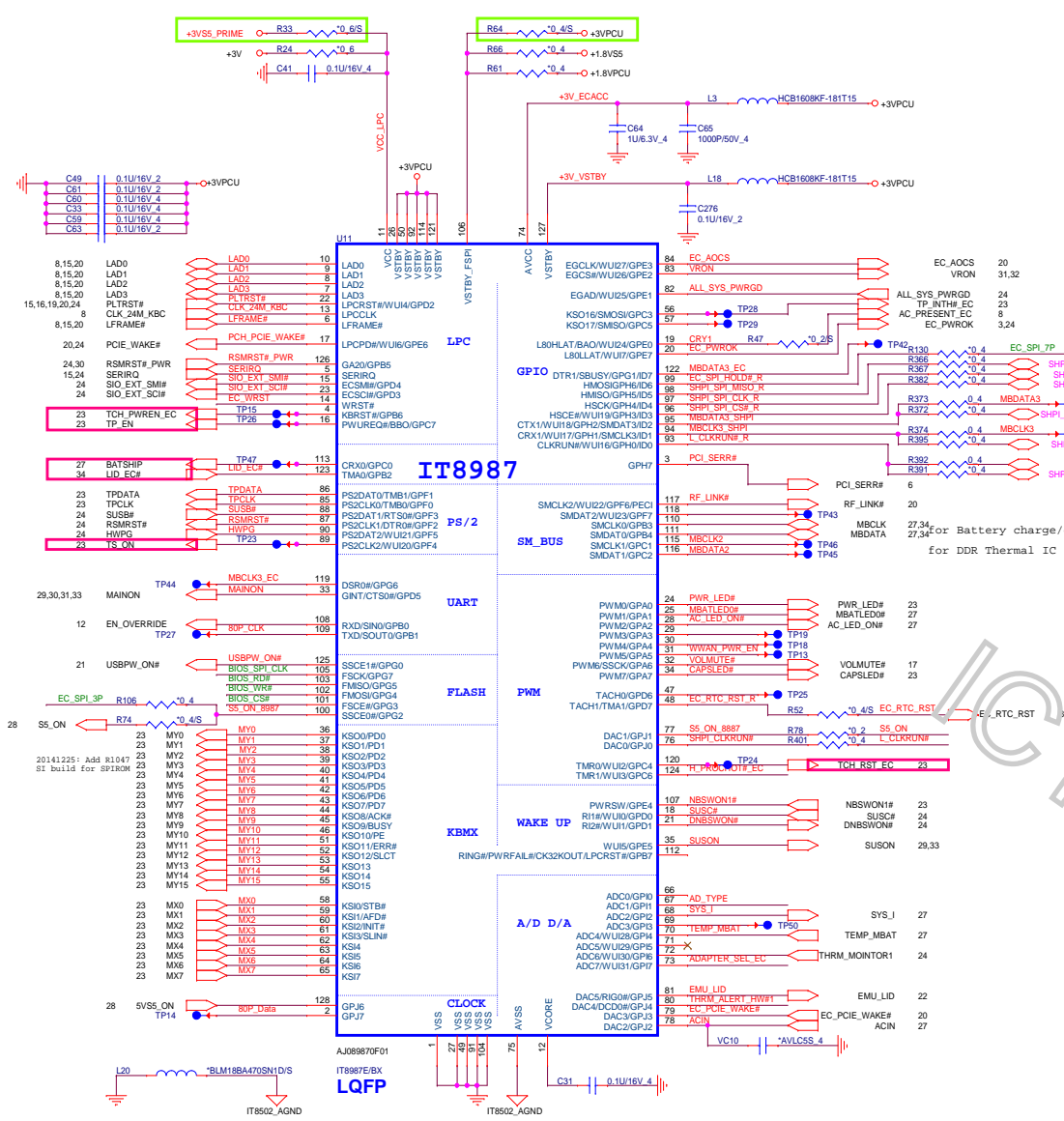

EC 8987 PN : AJ089870F01  
 EC 8887 PN : AJ088870T00  
 SI Build BOM Option

AKE5BY00000 / IC FLASH (8P) GD25D10BTIGR (SOP) / SPI, 3V, 1Mbit, SOP8 150mil.  
 AKE35ZNN000 / IC FLASH (8P) W25X10CLSNIG (SOIC) / SPI, 2.3-3.6V, 1Mbit, 8-pinSOIC 150mil.

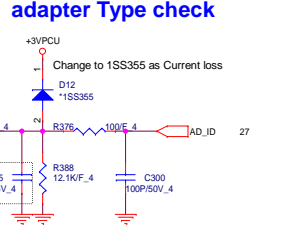
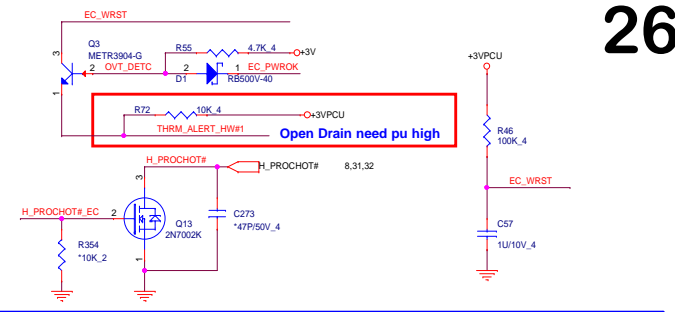

Adapter	90W	65W	45W
Ra	Stuff	Stuff	X
Rb	X	Stuff	Stuff

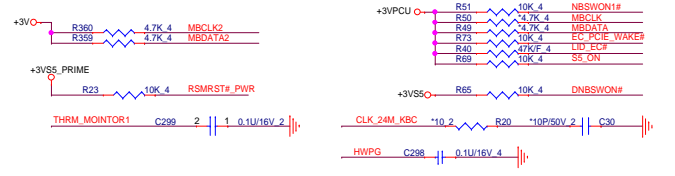

Power Button Reset

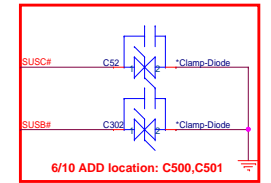

4,14,15,16,17,19,21,22,23,24,25,33  
 8,10,20,23,24,27,28,34

**Quanta Computer Inc.**  
**PROJECT : OP9**

Size	Document Number	Rev.
C	EC (IT8987)	1A
Date:	Tuesday, June 07, 2016	Sheet : 26 of 37

DC\_JACK/45/65W

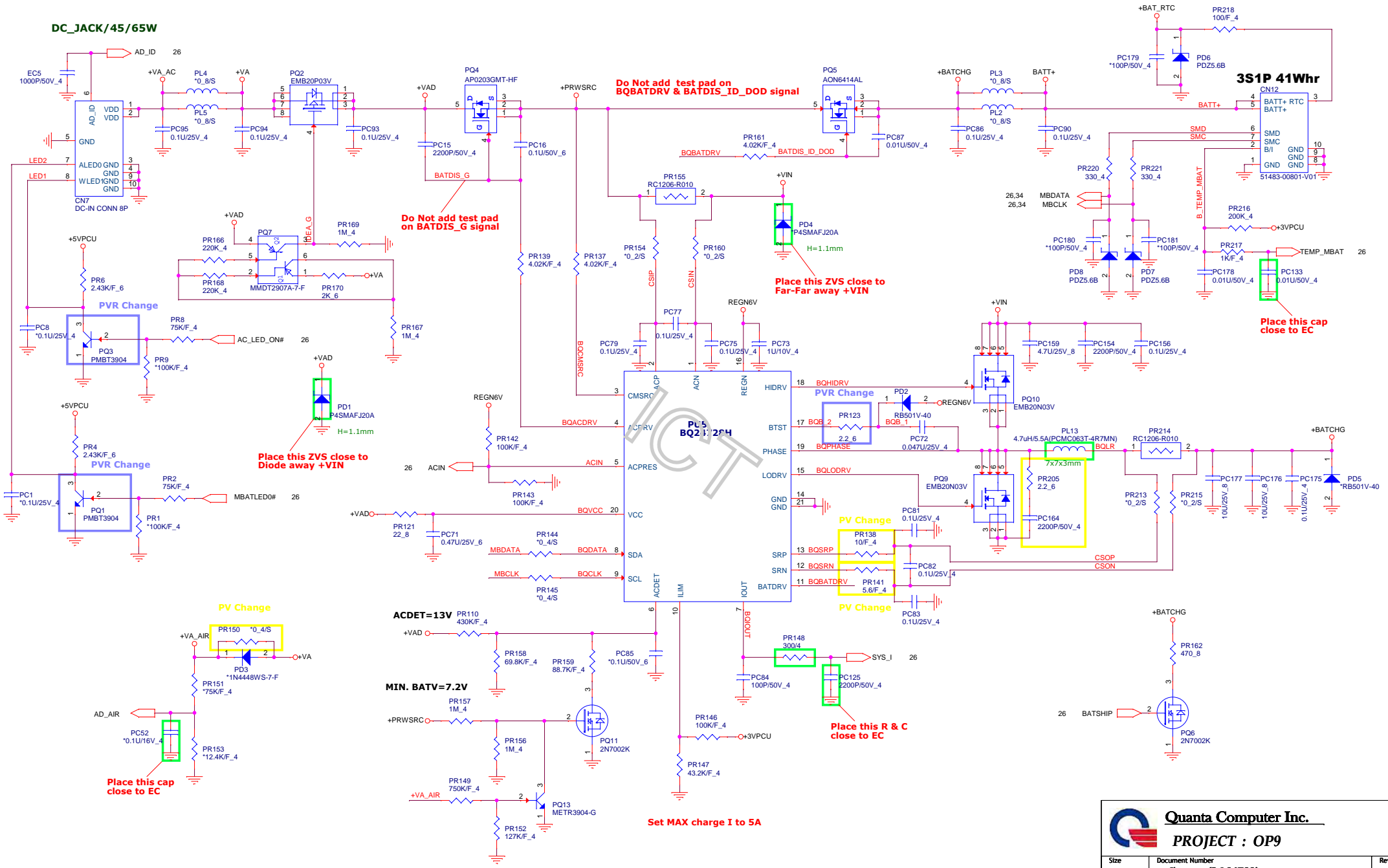

Do Not add test pad on BQBATDRV & BATDIS\_ID\_DOD signal

Do Not add test pad on BATDIS\_G signal

Place this ZVS close to Far-Far away +VIN

Place this cap close to EC

Place this ZVS close to Diode away +VIN

Place this cap close to EC

Place this R & C close to EC

Set MAX charge I to 5A

**Quanta Computer Inc.**  
**PROJECT : OP9**

Size Custom	Document Number <b>Charger (BQ24228)</b>	Rev. 1A
Date: Tuesday, June 07, 2016	Sheet : 27	of 37

DC/DC +3VS5/+5VS5

+3VPCU 8,10,20,23,24,26,27,34  
 +5VPCU 27,30,33

+VIN 22,25,27,29,31,32  
 +3VS5 2,3,5,10,15,20,23,24,25,26,30,31,32,33  
 +5VS5 21,25,29,30,31,32,33  
 +1.8VPCU 26

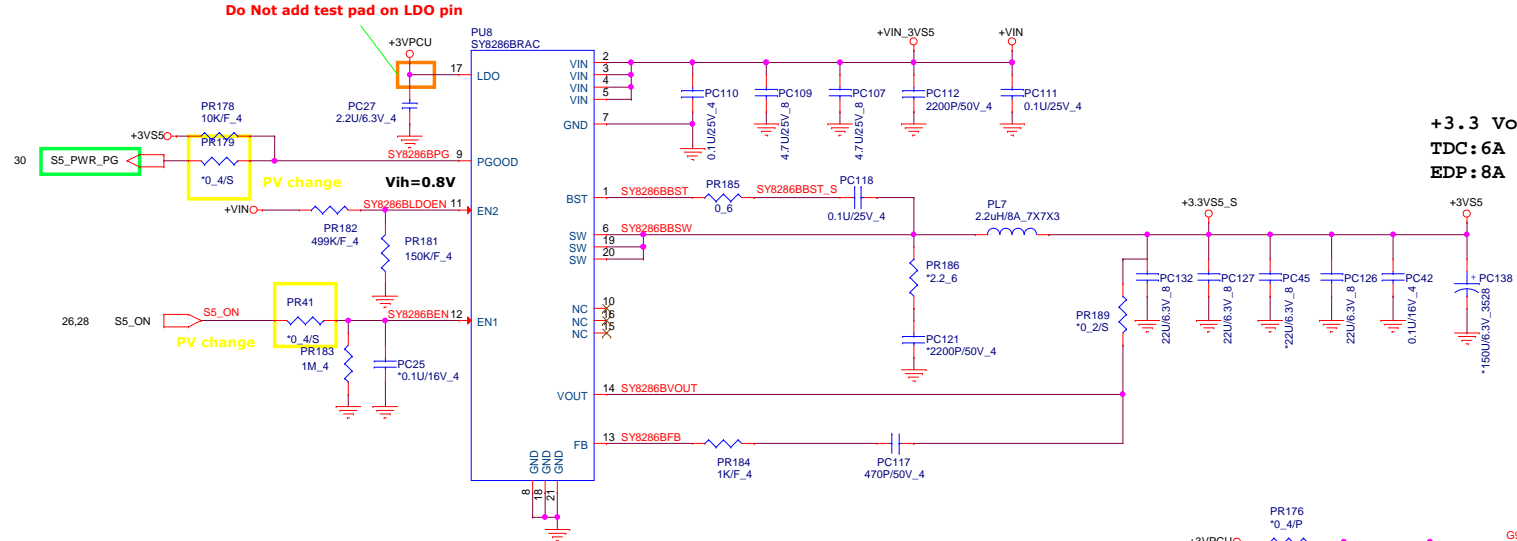

**+3.3 Volt +/- 5%**  
**TDC: 6A**  
**EDP: 8A**

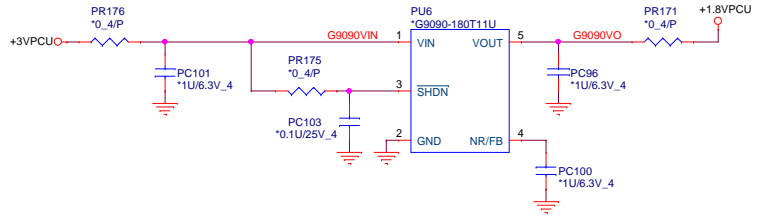

**+5 Volt +/- 5%**  
**TDC: 6A**  
**EDP: 8A**

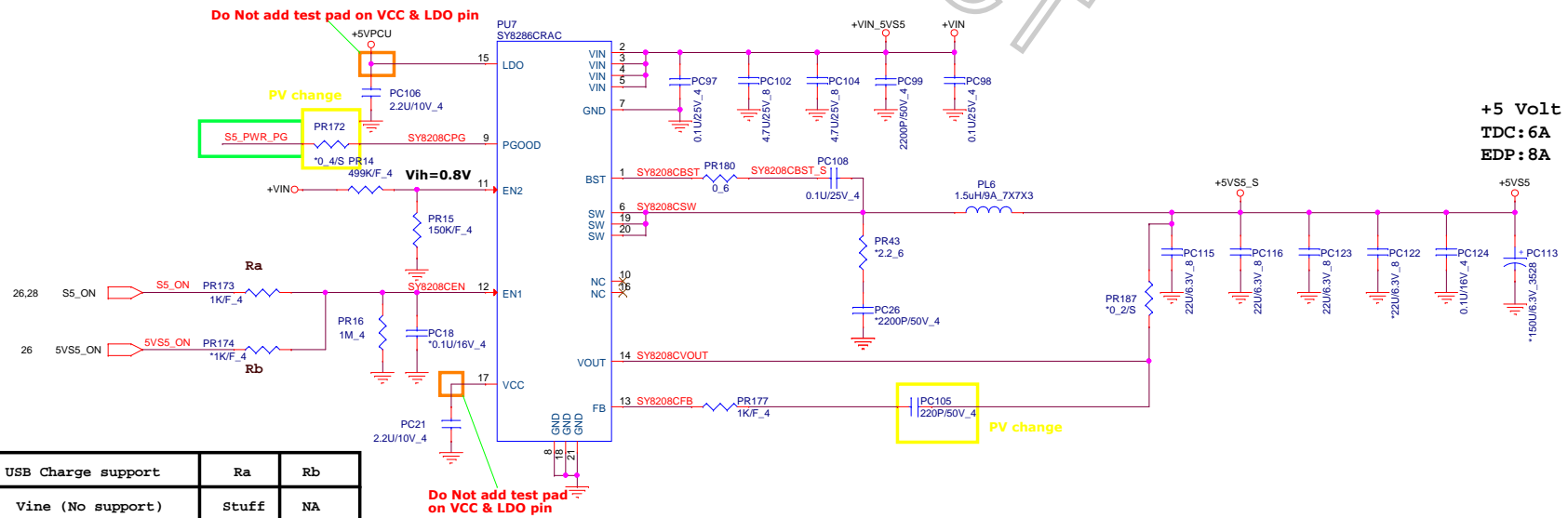

Do Not add test pad on VCC & LDO pin

Do Not add test pad on VCC & LDO pin

USB Charge support	Ra	Rb
Vine (No support)	Stuff	NA
Envy (Support)	NA	Stuff

**Quanta Computer Inc.**  
**PROJECT : OP9**

Size	Document Number	Rev.
Custom	3/5VS5 (SY8286B/SY8286C)	1A
Date:	Tuesday, June 07, 2016	Sheet : 28 of 37

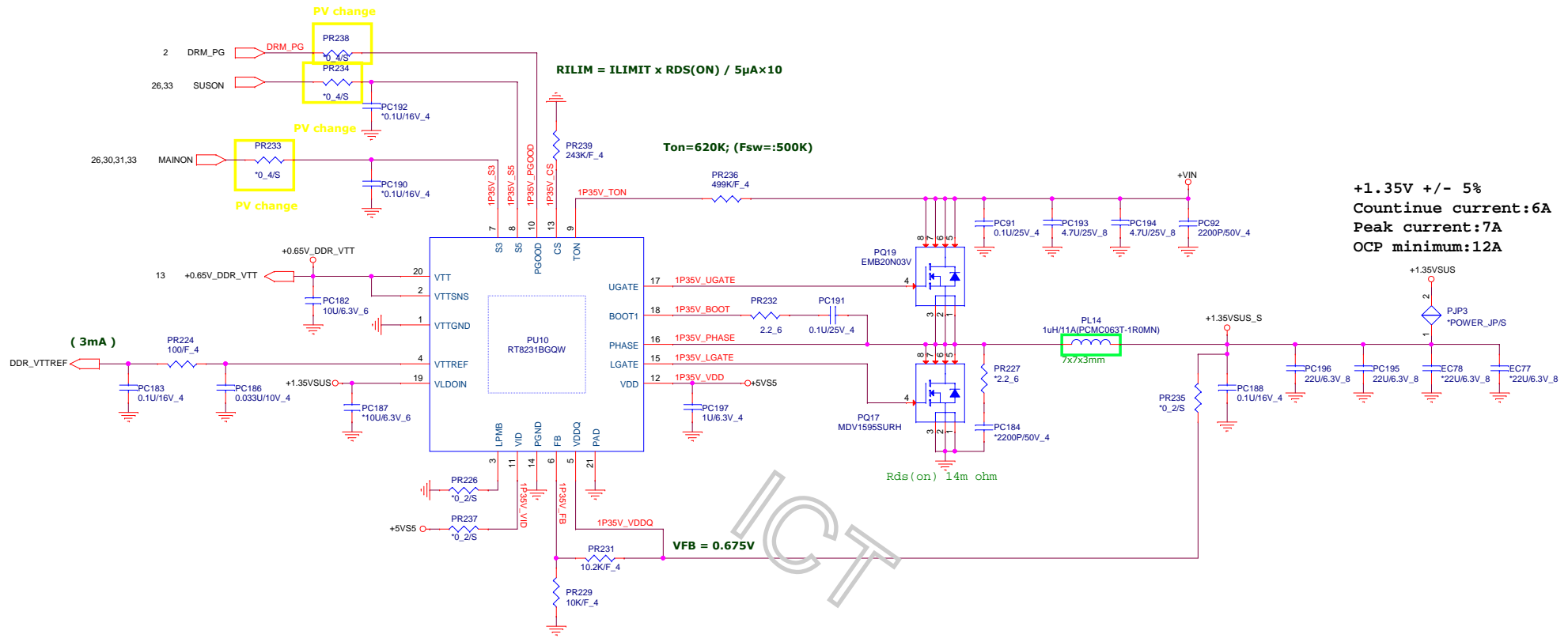

+1.35VSUS 2,3,10,13,25

		<b>PROJECT : OP9</b>
Size	Document Number	Rev.
Custom	<b>DDR3 (RT8231B)</b>	1A
Date:	Tuesday, June 07, 2016	Sheet : 29 of 37

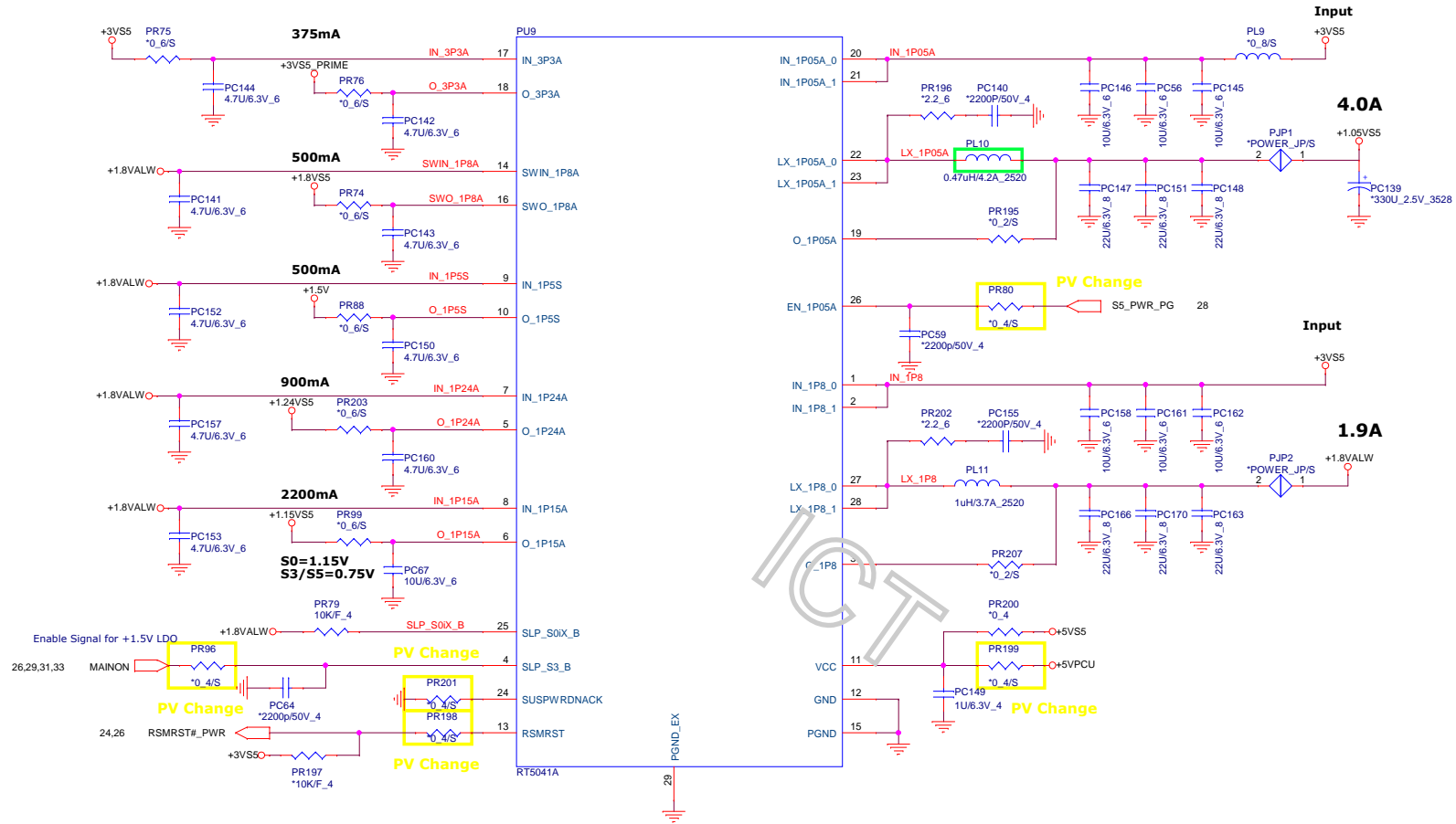

+3VS5	2,3,5,10,15,20,23,24,25,26,28,31,32,33
+1.8VALW	33
+1.8VS5	4,5,6,7,8,10,12,14,19,22,23,24,26,31
+3VS5_PRIME	10,26
+1.5V	10,17
+1.24VS5	10,25
+1.15VS5	9,30
+5VPCU	27,28,30,33
+1.05VS5	8,9,31,32
+1.15VS5	9,30
+5VPCU	27,28,30,33
+1.8V	4,5,14,19,22,23,24,33

**Quanta Computer Inc.**  
**PROJECT : OP9**

Size	Document Number	Rev.
Custom	<b>MCIC (RT5041A)</b>	1A
Date:	Tuesday, June 07, 2016	Sheet : 30 of 37

+3VS5	2,3,5,10,15,20,23,24,25,26,28,30,32,33
+1.05VS5	8,9,30,32
+5VS5	21,25,28,29,30,32,33
+VGG	9
+1.8VS5	4,5,6,7,8,10,12,14,19,22,23,24,26,30
+VIN	22,25,27,28,29,32

**Close to CPU**

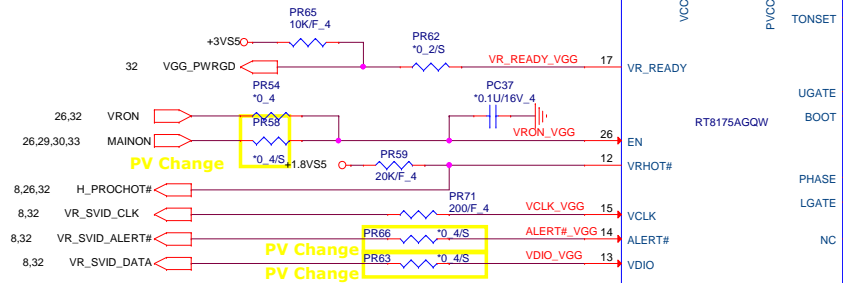
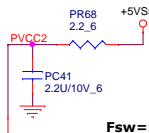
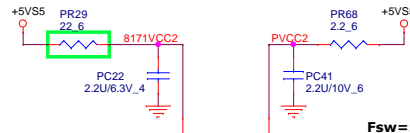
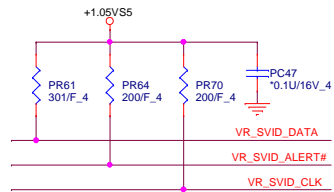

2016/3/23 updated

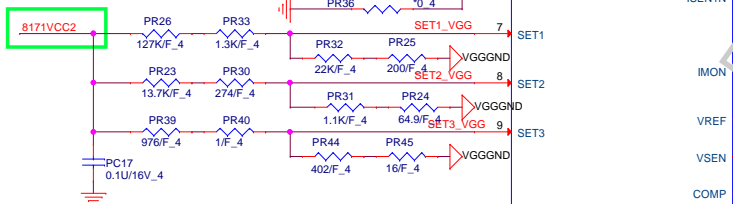

Place this NTC close to VGG HOT SPOT

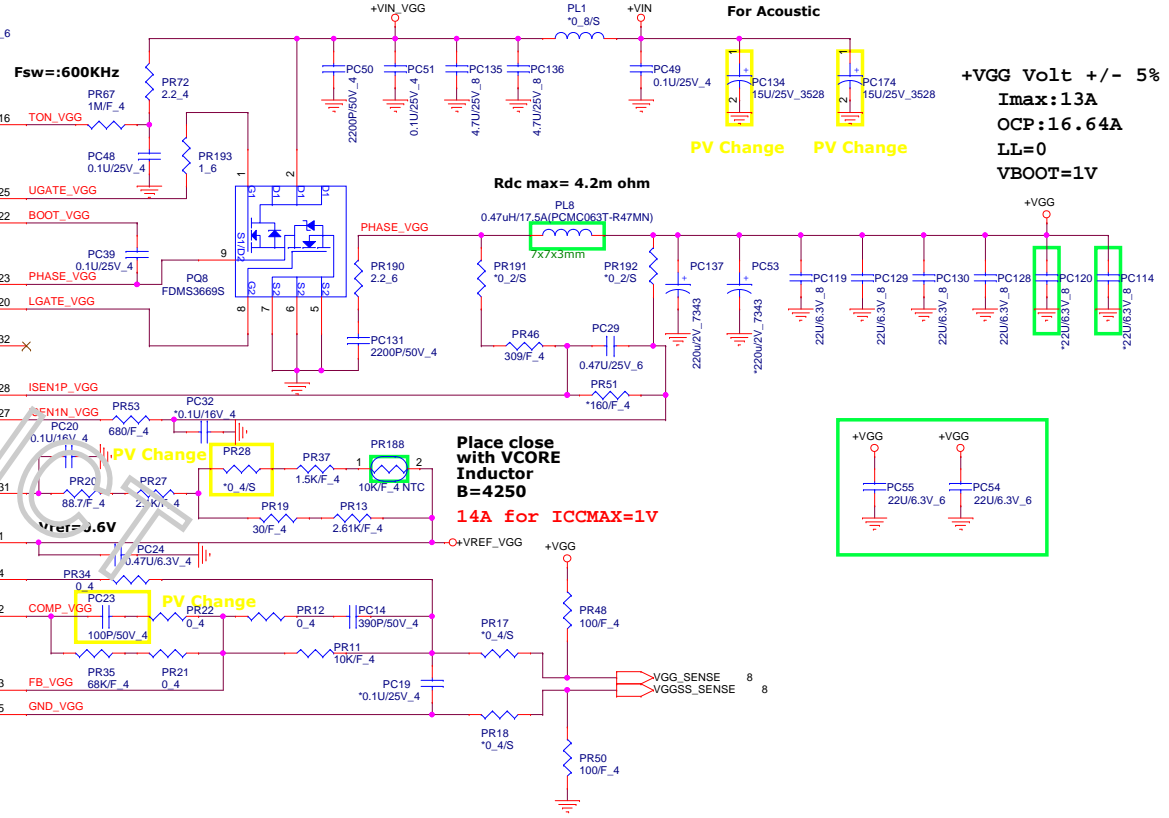
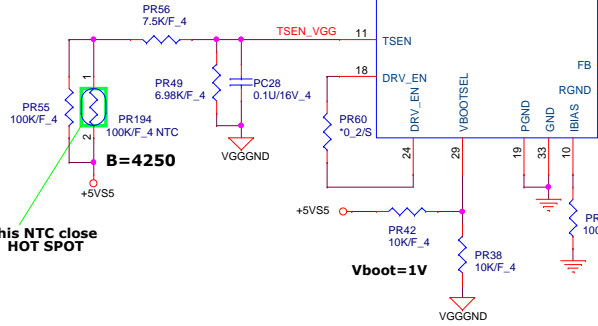

+VGG Volt +/- 5%  
 Imax:13A  
 OCP:16.64A  
 LL=0  
 VBOOT=1V

Place close with VCORE Inductor B=4250

14A for ICCMAX=1V

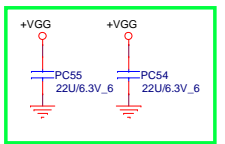

<b>Quanta Computer Inc.</b> <b>PROJECT : OP9</b>		
Size Custom	Document Number <b>VGG CORE(RT8175A)</b>	Rev. 1A
Date: Tuesday, June 07, 2016	Sheet : 31 of 37	

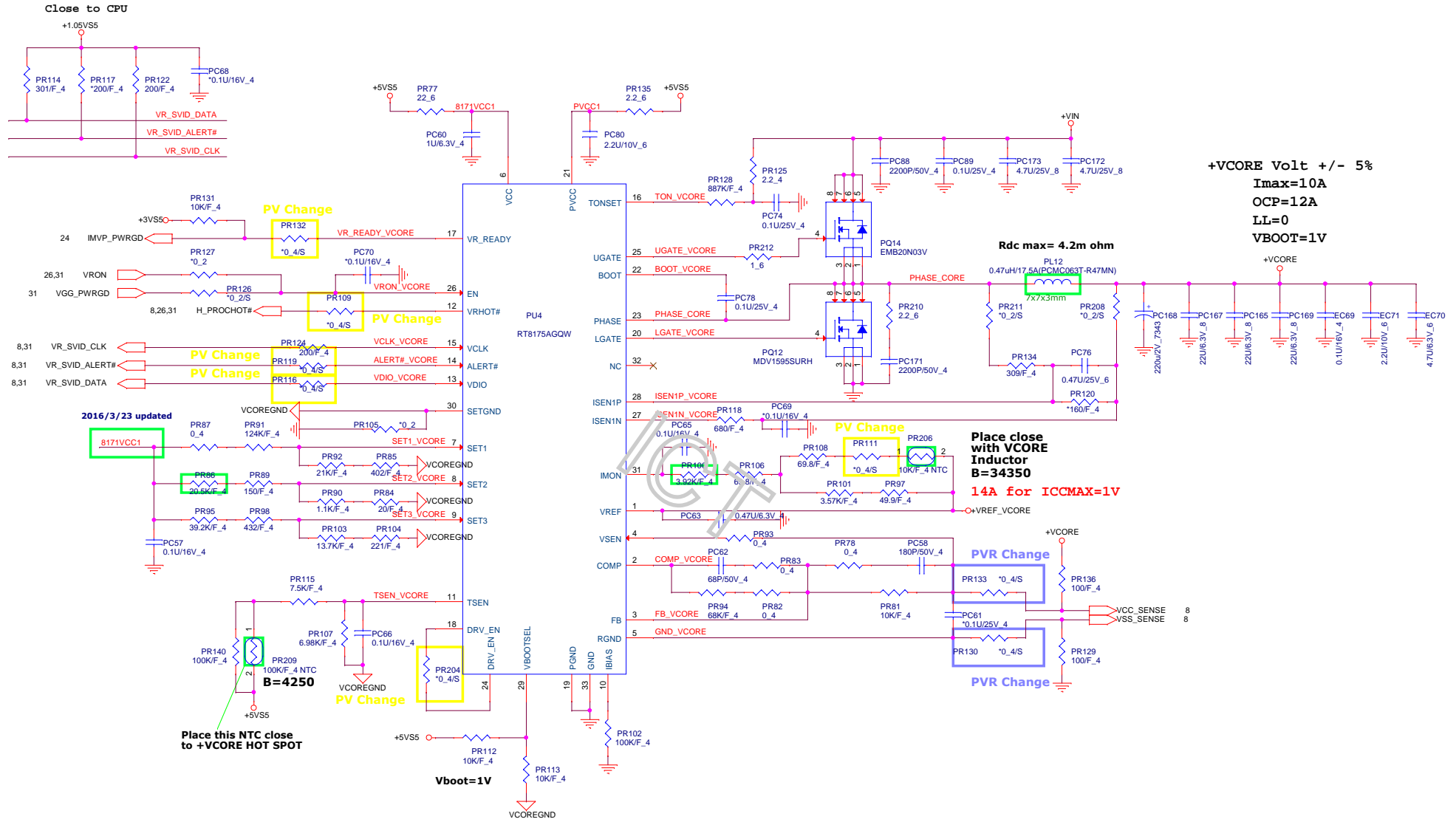

 <b>Quanta Computer Inc.</b> <b>PROJECT : OP9</b>		
Size Custom	Document Number <b>VCC CORE( RT8175A)</b>	Rev. 1A
Date: Tuesday, June 07, 2016	Sheet :	32 of 37



- +3V 4,14,15,16,17,19,21,22,23,24,25,26
- +5V 17,22
- +3VSUS 23
- +5VPCU 27,28,30
- +3VS5 2,3,5,10,15,20,23,24,25,26,28,30,31,32

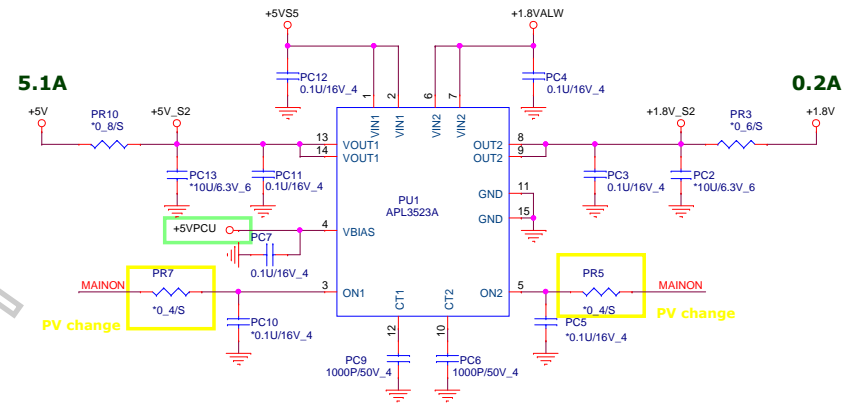
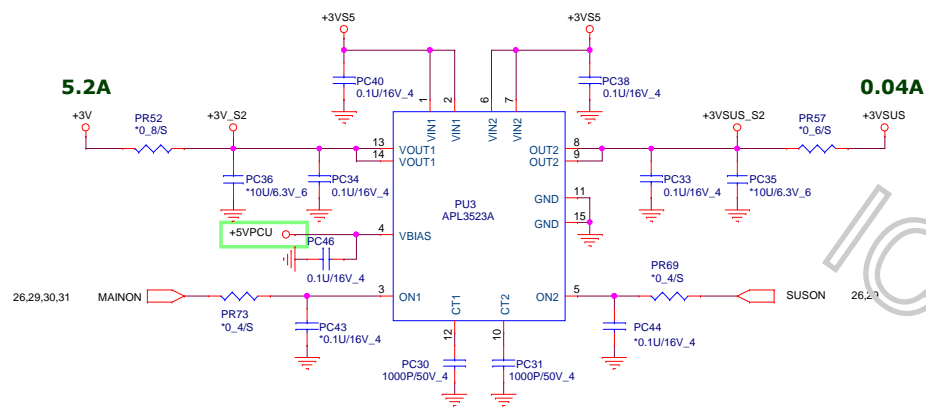

<b>Quanta Computer Inc.</b>		
<b>PROJECT : OP9</b>		
Size	Document Number	Rev.
Custom	<b>Load switch IC (APL3523A)</b>	1A
Date:	Tuesday, June 07, 2016	Sheet : 33 of 37

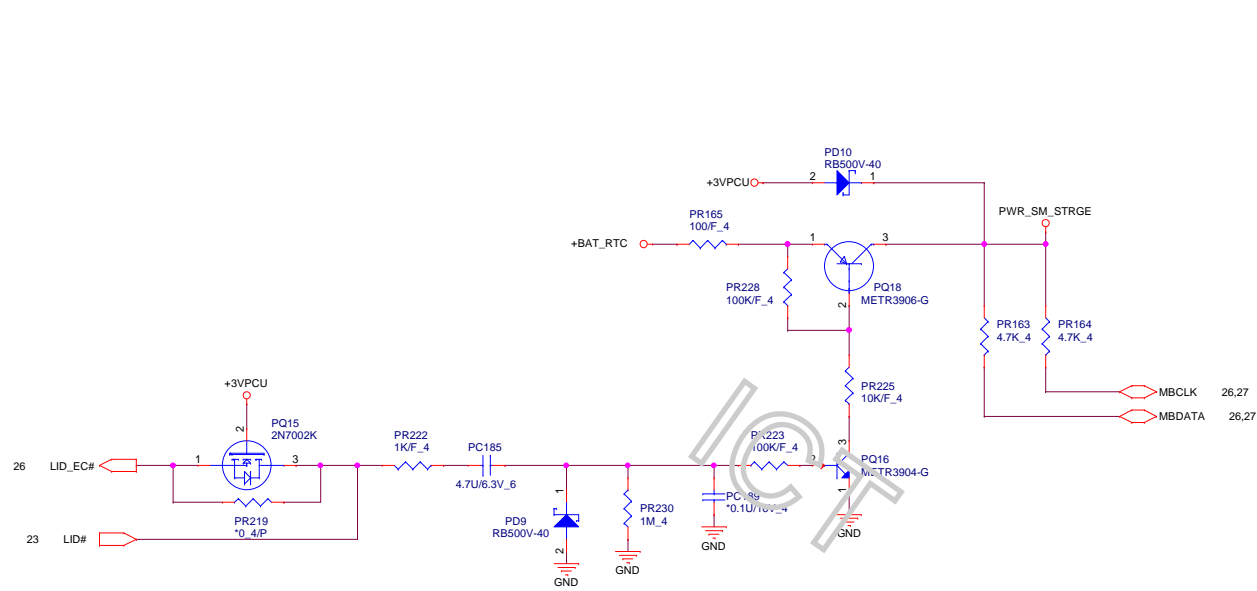

8,10,20,23,24,26,27,28  
23,27

+3VPCU

+BAT\_RTC

 <b>Quanta Computer Inc.</b> <b>PROJECT : OP9</b>		
Size Custom	Document Number <b>Storage Mode</b>	Rev. 1A
Date: Tuesday, June 07, 2016	Sheet : 34 of 37	

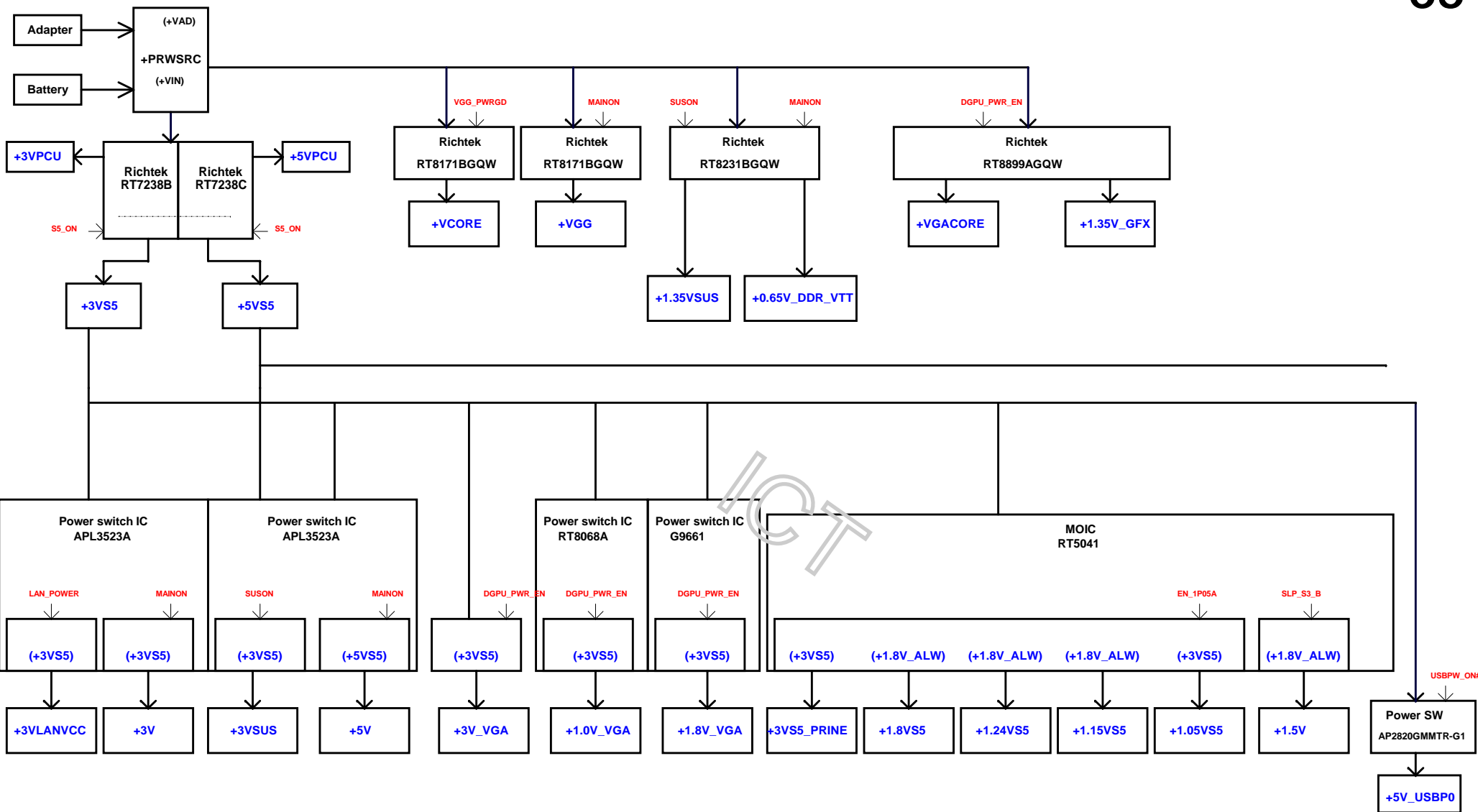

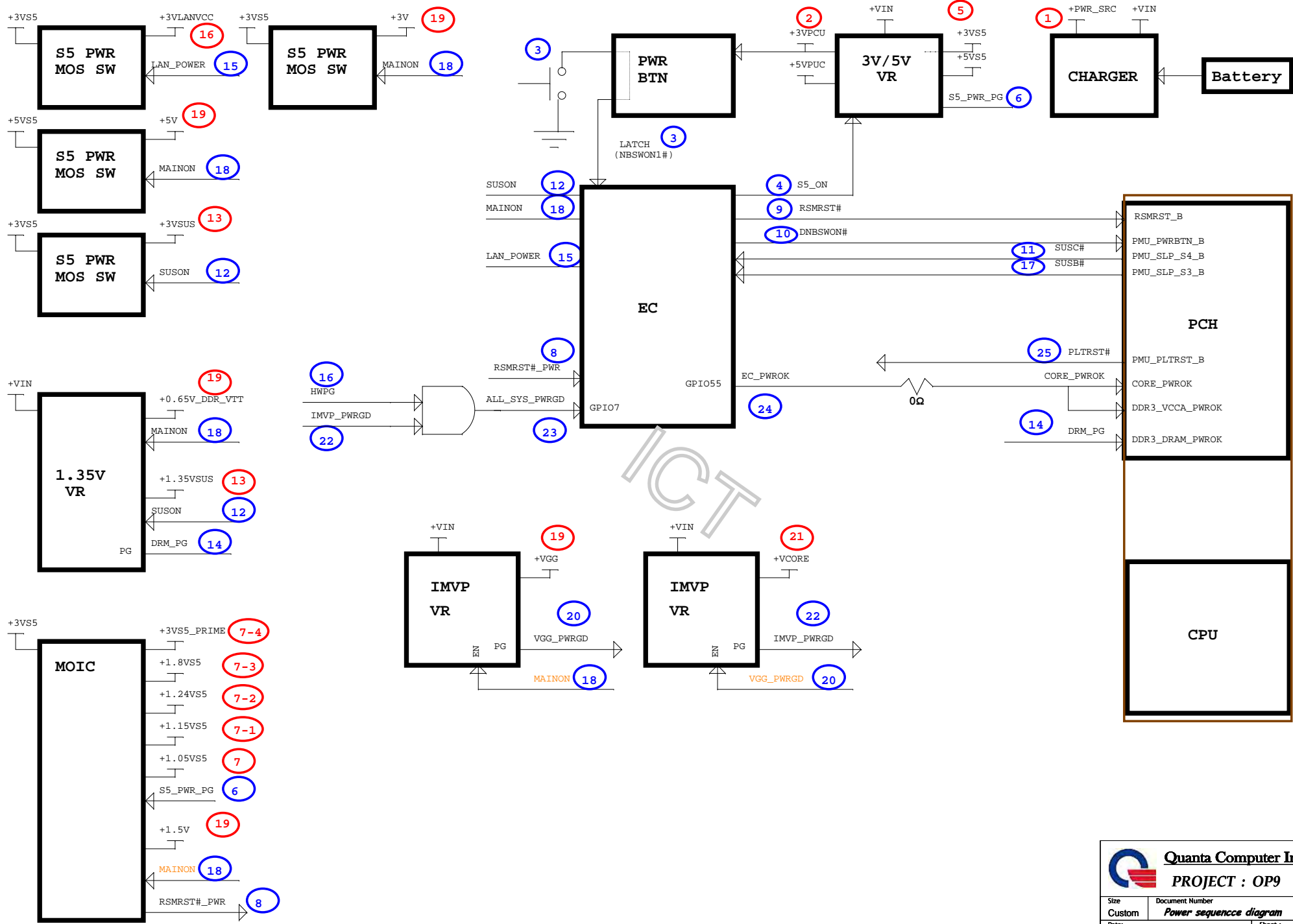

**Quanta Computer Inc.**  
**PROJECT : OP9**

Size Custom	Document Number <b>Power sequence diagram</b>	Rev. 1A
Date: Tuesday, June 07, 2016	Sheet : 36 of 37	

G3 to S0

S0

S0 to S3

S4/S5

