

# Xiaomi Poco M3 (J19S\_MB) Schematic Diagram



Xiaomi  
Smartphone

*Schematic*

*Diagram*



# I2C Configuration Table

GPIO4 GPIO5	AUDIO&NFC&BL
GPIO22 GPIO23	48M&R 8M
GPIO29 GPIO30	2M&2M&F 8M
GPIO96 GPIO97	<a href="https://Mobile1Tech.com">https://Mobile1Tech.com</a>
GPIO109 GPIO110	PL&M Sensor I2C
LPI_GPIO21 LPI_GPIO22	G&SAR Sensor I2C

Table of Content

Sheet	Content	Sheet	Content
01.	Block Diagram	24.	AUDIO SPK PA
02.	I2C Configuration Table	25.	GP_MIC_REV
03.	Table of Content	26.	SENSORS MOTOR
04.	GPIO MAP	27.	LCD TP_BL
05.	SM4250 Control/UFS/SDC1/SDC2	28.	REAR&FRONT CAM/pm8008
06.	SM4250 LPDDR4X	29.	Fingerprint
07.	SM4250 CSI/DSI	30.	BTB_CONN OVP
08.	SM4250 GPIO (Internal Codec)	31.	RF_WTR3925 Pin Out
09.	SM4250 Power (Core)	32.	RF_WTR3925_RF_TX
10.	SM4250 Power (Other, LP4X)	33:	RF_WTR3925_RF_PRX
11.	SM4250 Ground	34:	RF_WTR3925_RF_DRX
12.	PM4250 CLKs/Control_GND	35:	RF_WIFI_BT_GPS
13.	PM4250 Buck Converter1	36:	RF_WCN3950
14.	PM4250 Buck Converter2	37:	RF_NFC
15.	PM4250 LDO	38:	QET
16.	<a href="https://Mobile1Tech.com">https://Mobile1Tech.com</a>	39:	Test Points
17.	SD SIM		
18.	PMI632 CHARGING BATCON		
19.	PMI632 Control/Display/GPIO		
20.	uFS		
21.	AUXADC_Thermal		
22.	Audio_CODEC WCD9370		
23.	Key PAD		

## GPIO MAP SM6115 GPIO Configuration

GPIO_0	NFC_SPI_MISO	GPIO_42		GPIO_84	
GPIO_1	NFC_SPI_MOSI	GPIO_43	GRFC_6	GPIO_85	LCM_RST
GPIO_2	NFC_SPI_CLK	GPIO_44	GRFC_7	GPIO_86	NFC_CLK_REQ
GPIO_3	NFC_SPI_CS1_N	GPIO_45	GRFC_8	GPIO_87	WCN_SW_CTRL
GPIO_4	APPS_I2C_SDA	GPIO_46	GRFC_9	GPIO_88	SD_DET
GPIO_5	APPS_I2C_SCL	GPIO_47	GRFC_10	GPIO_89	Modem_ID3
GPIO_6	TP_SPI_MISO	GPIO_48		GPIO_90	MSS_LTE_COXM_TXD
GPIO_7	TP_SPI_MOSI	GPIO_49	GRFC_12	GPIO_91	MSS_LTE_COXM_RXD
GPIO_8	WCN_UART_CTS_N	GPIO_50		GPIO_92	WCD9370_RST_N
GPIO_9	WCN_UART_RFR_N	GPIO_51		GPIO_93	FP_POWER_EN
GPIO_10	WCN_UART_TX_N	GPIO_52		GPIO_94	FORCED_USB_BOOT_POL_SEL
GPIO_11	WCN_UART_RX_N	GPIO_53	RFFE1_DATA	GPIO_95	FORCED_USB_BOOT
GPIO_12	MSM_UART_TX	GPIO_54	RFFE1_CLK	GPIO_96	PA_I2C_SDA
GPIO_13	MSM_UART_RX	GPIO_55		GPIO_97	PA_I2C_SCL
GPIO_14	FP_SPI_MISO	GPIO_56		GPIO_98	PA_SPK_RST
GPIO_15	FP_SPI_MOSI	GPIO_57	RFFE3_DATA	GPIO_99	LCD_ID0
GPIO_16	FP_SPI_CLK	GPIO_58	RFFE3_CLK	GPIO_100	LCD_ID1
GPIO_17	FP_SPI_CS_N	GPIO_59		GPIO_101	LCD_ID2
GPIO_18	CAM_3_PDN	GPIO_60		GPIO_102	USB_SS_SEL
GPIO_19	CAM_F_RST	GPIO_61		GPIO_103	CTP_RST
GPIO_20	CAM_R_MCLK	GPIO_62	RFFE5_DATA	GPIO_104	CTP_EINT
GPIO_21	CAM_F_MCLK	GPIO_63	RFFE5_CLK	GPIO_105	SMB_STAT
GPIO_22	CAM_I2C_SDA0	GPIO_64	EXT_GPS_LNA_EN0	GPIO_106	ALS_EINT
GPIO_23	CAM_I2C_SCL0	GPIO_65	CH0_GSM_TX_PHASE_D0	GPIO_107	PA_RSV_RST
GPIO_24	CAM_2_RST	GPIO_66	CAM_R_RST	GPIO_108	DSI_TE
GPIO_25	PM8008_INT_N	GPIO_67	NC	GPIO_109	Sensor_I2C_SDA
GPIO_26	PM8008_RST_N	GPIO_68	Modem_ID1	GPIO_110	Sensor_I2C_SCL
GPIO_27	CAM_MCLK_2	GPIO_69	SUB_ID	GPIO_111	CONFIG0
GPIO_28	CAM_MCLK_3	GPIO_70	NFC_ENABLE	GPIO_112	CONFIG1
GPIO_29	CAM_I2C_SDA1	GPIO_71	NFC_INT_N	LPI_GPIO_0	SWR_TX_CLK
GPIO_30	CAM_I2C_SCL1	GPIO_72	TP_SPI_SCLK	LPI_GPIO_1	SWR_TX_DATA0
GPIO_31	NFC_DWL_REQ	GPIO_73	UIM2_DATA	LPI_GPIO_2	SWR_TX_DATA1
GPIO_32	FP_ID1	GPIO_74	UIM2_CLK	LPI_GPIO_3	SWR_RX_CLK
GPIO_33	FP_ID2	GPIO_75	UIM2_RESET	LPI_GPIO_4	SWR_RX_DATA0
GPIO_34	FP_EINT	GPIO_76	UIM2_DET	LPI_GPIO_5	SWR_RX_DATA1
GPIO_35	FP_RST	GPIO_77	UIM1_DATA	LPI_GPIO_14	QCA_SB_CLK
GPIO_36	G_EINT_ACC	GPIO_78	UIM1_CLK	LPI_GPIO_15	QCA_SB_DATA
GPIO_37	GRFC_0	GPIO_79	UIM1_RESET	LPI_GPIO_21	Sensor_I3C_SDA
GPIO_38	GRFC_1	GPIO_80	UIM1_DET	LPI_GPIO_22	Sensor_I3C_SCL
GPIO_39	GRFC_2	GPIO_81	TP_SPI_CS_N	LPI_GPIO_25	<a href="https://Mobile1Tech.com">https://Mobile1Tech.com</a>
GPIO_40	ANT_TEST	GPIO_82	Modem_ID2	LPI_GPIO_26	
GPIO_41		GPIO_83	Modem_ID4		

## PM4250 GPIO Configuration

GPIO_1	DSP_CLK	GPIO_8	USB_MOS_CTRL
GPIO_2	FLASH_THERMAL	GPIO_9	
GPIO_3	USB1_THERM		
GPIO_4	USB2_THERM		
GPIO_5	KEY_VOL_UP		
GPIO_6	BB_THERM		
GPIO_7	Modem_ID5		

图纸街-让维修更容易!  
<https://www.tuzhijie.com>

## PMI632 GPIO Configuration

GPIO_1	NC	GPIO_8	ISNS_SMB_M
GPIO_2	STAT_CHG		
GPIO_3	PMI632_THERM		
GPIO_4			
GPIO_5			
GPIO_6			
GPIO_7	ISNS_SMB_P		

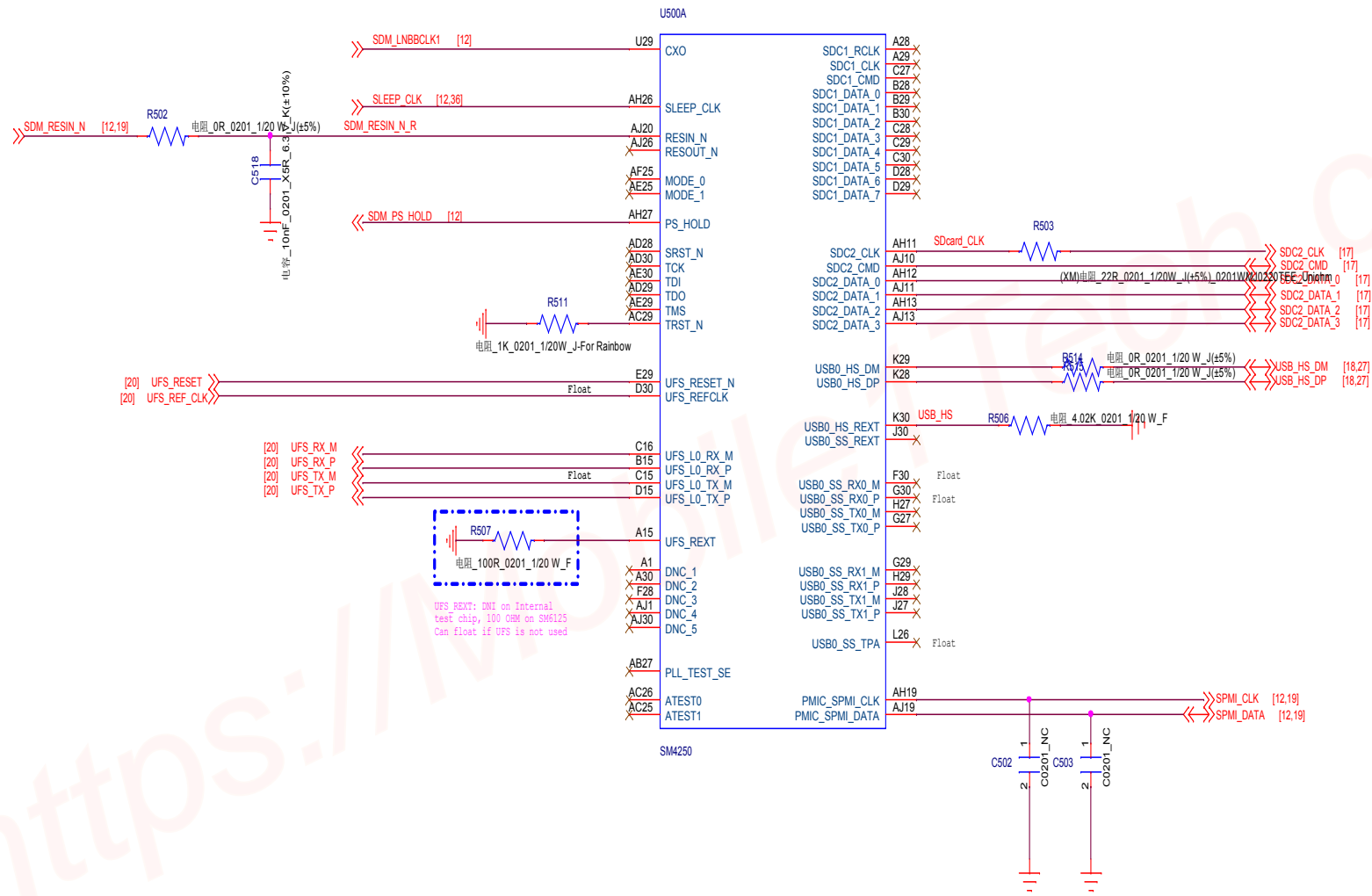

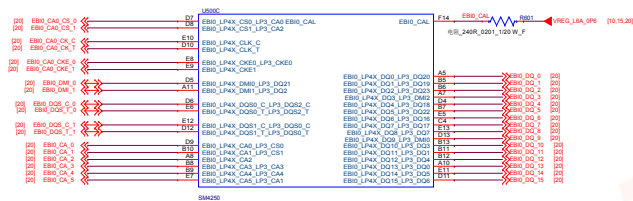

<https://Mobile1Tech.com>

Main MONO Camera 48M

Rear Camera 8M

2M =Macro

Front Camera 8M

2M=Depth

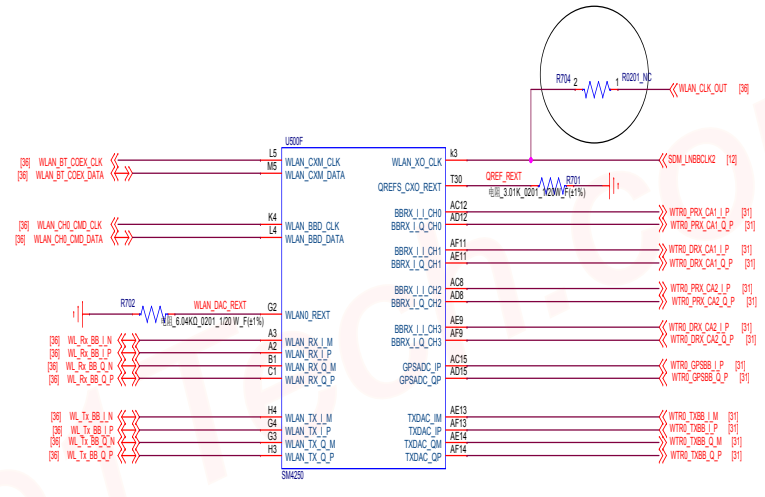
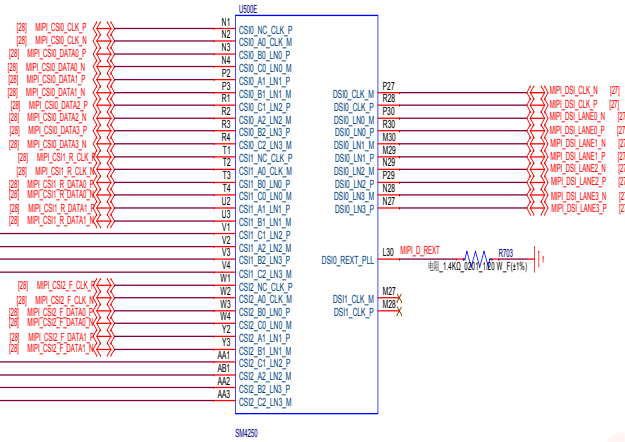

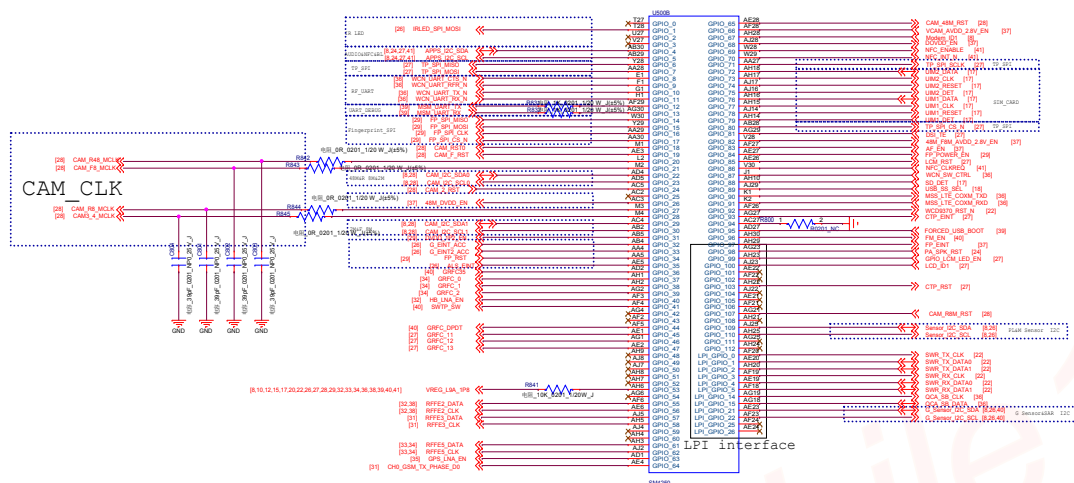

BOOT Config GPIOs	Functionality
GPIO_95	Forced_USB_BOOT
BOOT Config[0]:GPIO_48	WDOG_DISABLE
BOOT Config[1]:GPIO_50	FASTBOOT_SEL[0]
BOOT Config[2]:GPIO_51	FASTBOOT_SEL[1]
BOOT Config[3]:GPIO_53	FASTBOOT_SEL[2]
BOOT Config[4]:GPIO_55	FASTBOOT_SEL[3]
GPIO_94	Forced_USB_BOOT_POL_SEL

FASTBOOT_SEL[3:0]	BOOT OPTIONS
0b0000	0:Default(eMMC>SD>eDL(eDL path-USB only))
0b0001	1:SD>eMMC>eDL(eDL path-USB only)
0b0010	2:SD>eDL(eDL path-USB only)
0b0011	3:USB>eDL(eDL path-SD then USB)
0b0100	5:UFS HS G1>SD>eDL(eDL path-USB only)
0b0101	4:SD>UFS HS G1>eDL(eDL path-USB only)
0b1100	6:UFS HS G1>eDL(eDL path-USB only)
0b0111	7:eMMC>SD>eDL(eDL path-USB only)
0b1000	8:eMMC>eDL(eDL path-USB only)

I2C pull up

Hardware&Board ID  
[www.tuzhijie.com](http://www.tuzhijie.com)

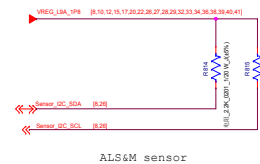
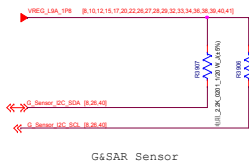
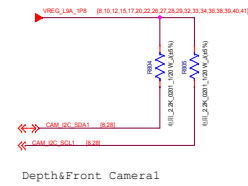
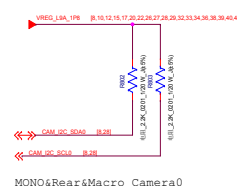
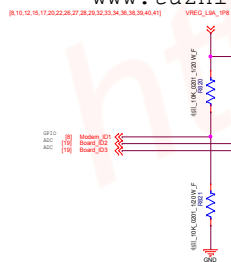

<https://Mobile1Tech.com>

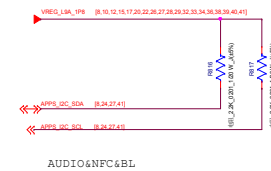



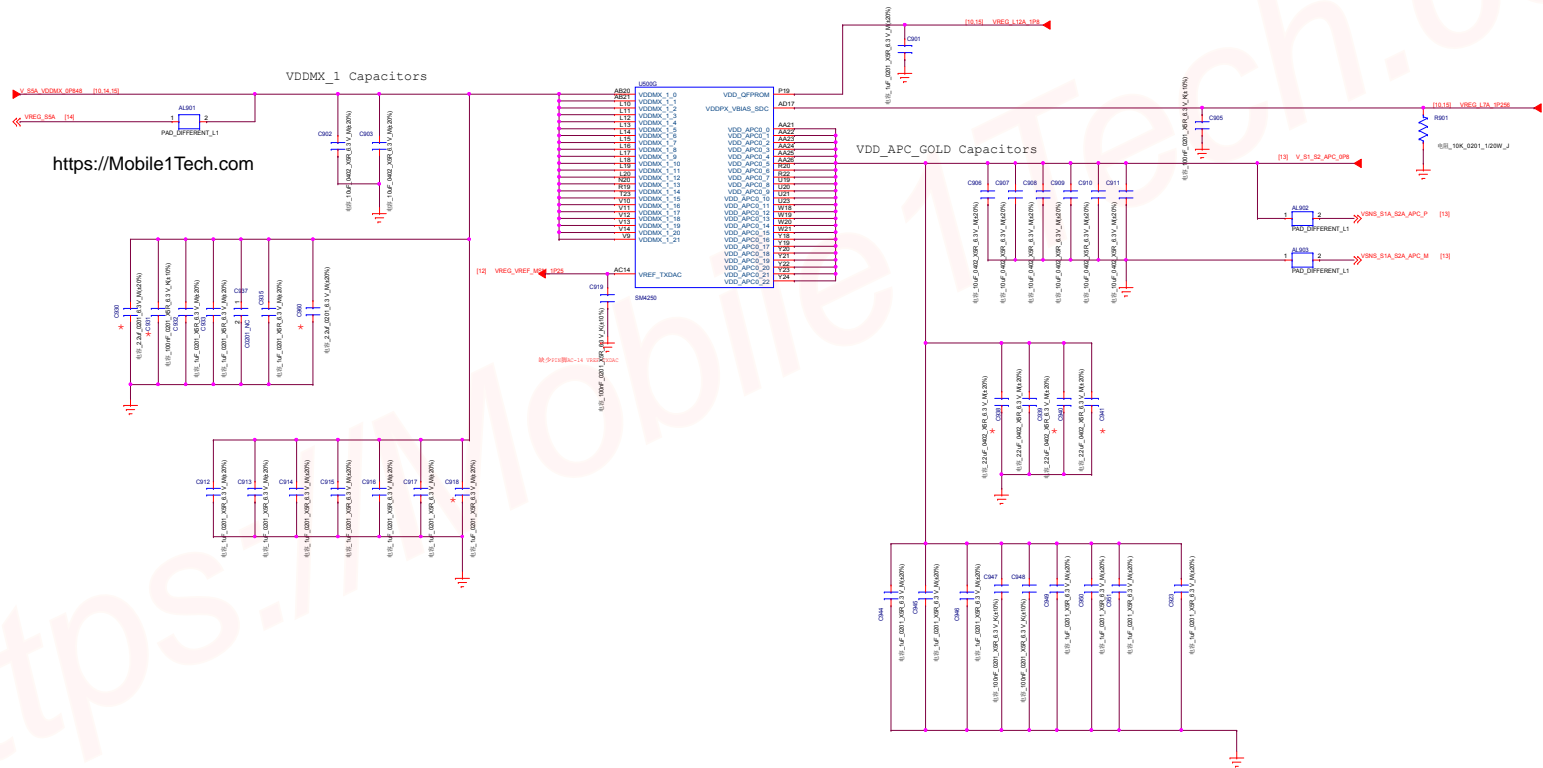

https://Mobile1Tech.com

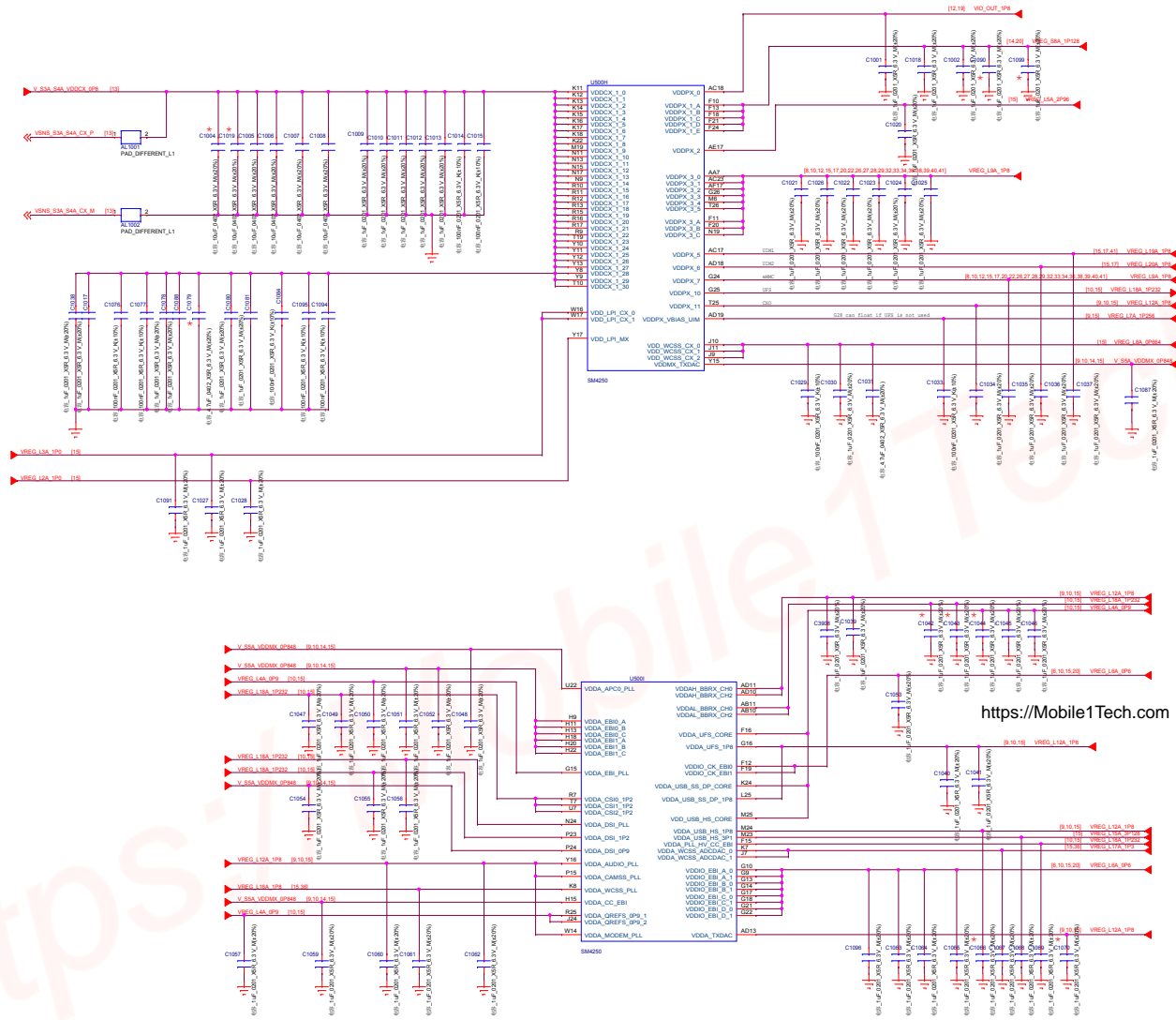

<https://Mobile1Tech.com>



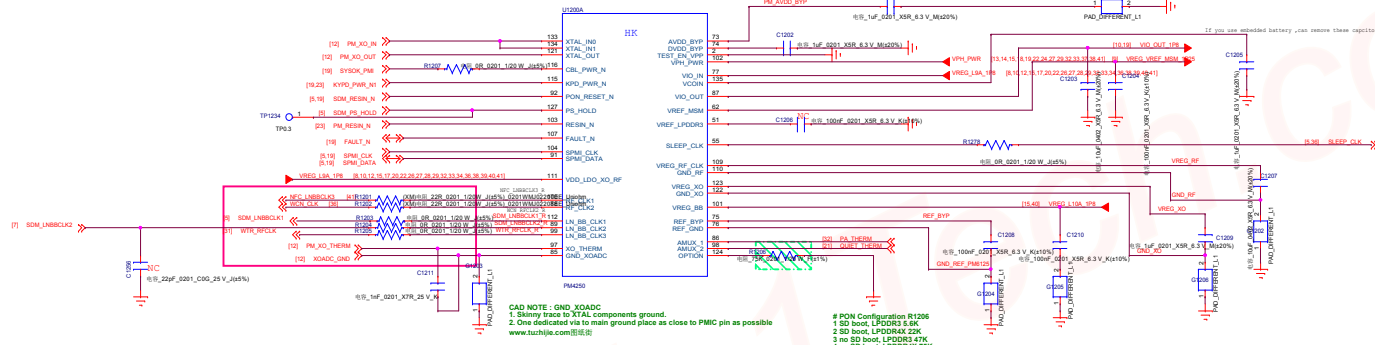
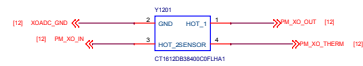

**CAD NOTE : GND\_XOADC**  
 1. Show trace to XTAL components ground.  
 2. One dedicated via to main ground plane as close to PMIC pin as possible  
[www.ti.com/lit/zip/SN748](http://www.ti.com/lit/zip/SN748)

**# PON Configuration R1206**  
 1 SD boot, LPDDR3 5.6K  
 2 SD boot, LPDDR4X 22K  
 3 no SD boot, LPDDR3 47K  
 4 no SD boot, LPDDR4X 75K



Option Pin Resistor Value	Configuration
5.6K	No External Boost Bypass, SD Card Boot, LPDDR3
22K	No External Boost Bypass, SD Card Boot, LPDDR4x
47K	No External Boost Bypass, No SD Card Boot, LPDDR3
75K	No External Boost Bypass, No SD Card Boot, LPDDR4x
130K	External Boost Bypass, SD Card Boot, LPDDR3
240K	External Boost Bypass, SD Card Boot, LPDDR4x
330K	External Boost Bypass, No SD Card Boot, LPDDR3
750K	External Boost Bypass, No SD Card Boot, LPDDR4x

Option Pin Resistor Value	Configuration
5.6K	No External Boost Bypass, SD Card Boot, LPDDR3
22K	No External Boost Bypass, SD Card Boot, LPDDR4x
47K	No External Boost Bypass, No SD Card Boot, LPDDR3
75K	No External Boost Bypass, No SD Card Boot, LPDDR4x
130K	External Boost Bypass, SD Card Boot, LPDDR3
240K	External Boost Bypass, SD Card Boot, LPDDR4x
330K	External Boost Bypass, No SD Card Boot, LPDDR3
750K	External Boost Bypass, No SD Card Boot, LPDDR4x

Note: SD Card Boot implies the voltages for SD card will be enabled during Power On sequence  
 No SD Card Boot implies the voltages for SD card will be disabled during Power On sequence

Note: SD Card Boot implies the voltages for SD card will be enabled during Power On sequence  
 No SD Card Boot implies the voltages for SD card will be disabled during Power On sequence

<https://Mobile1Tech.com>

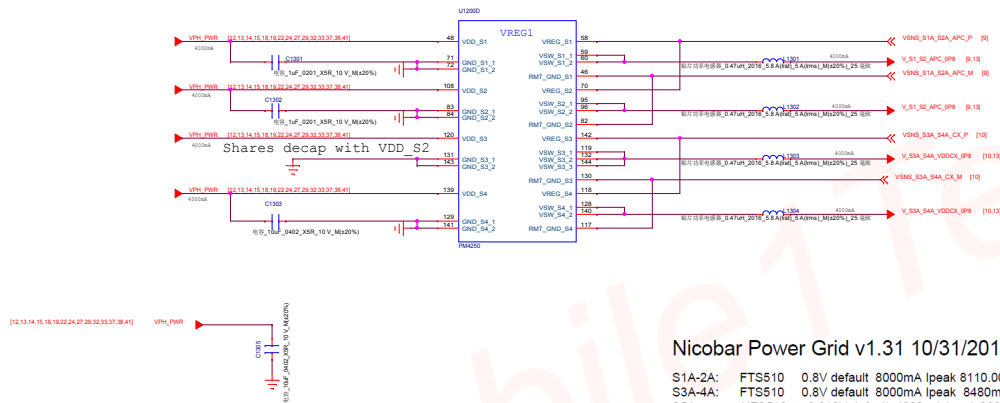

Nicobar Power Grid v1.31 10/31/2018

S1A-2A:	FTS510	0.8V default	8000mA ipeak	8110.00mA	APC
S3A-4A:	FTS510	0.8V default	8000mA ipeak	8480mA	CX, MODEM
S5A:	HFS510	0.912V default	4000mA ipeak	3620.00mA	EBI, MX, nLDO
S6A:	HFS510	1.352V default	4000mA ipeak	1560mA	LDO
S7A:	HFS510	2.04V default	2500mA ipeak	2350mA	LDO
S8A:	FTS510	1.128V default	4000mA ipeak	1790mA	LDO, LPDDR4x

<https://Mobile1Tech.com>

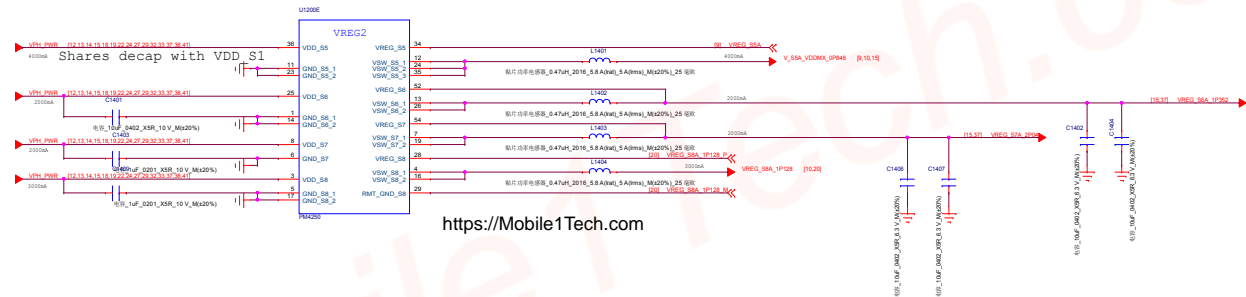

<https://Mobile1Tech.com>

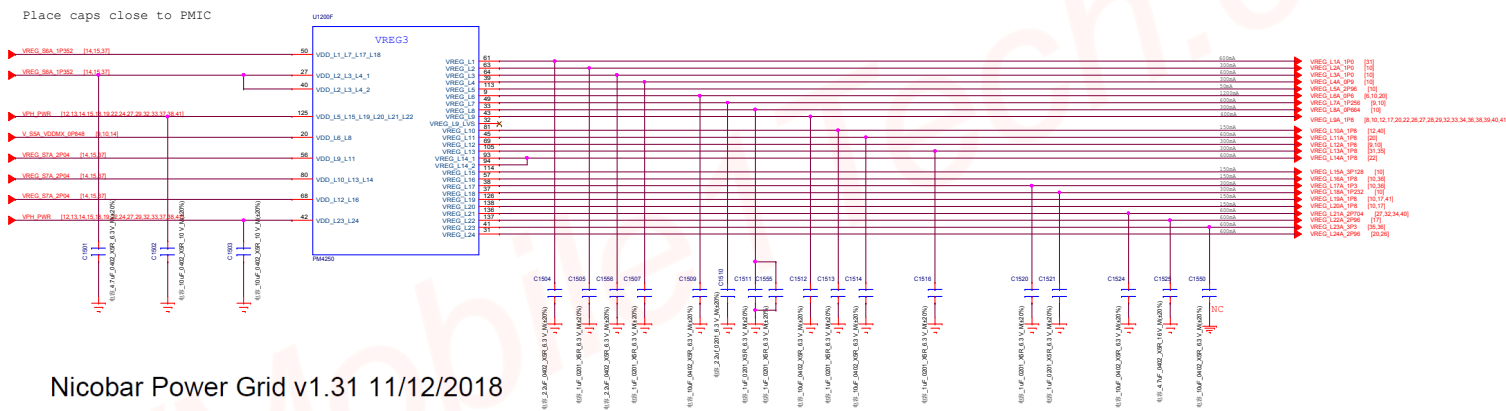

Nicobar Power Grid v1.31 11/12/2018

LDO Type	Source	V_default (est)	Target Pin#
L1 N600	S6A	1.2V (625)	QLN, SDR 1, 2, 61
L2 N300	S8A	1V (320)	SDR VDD 1, 0V 63
L3 N600	S8A	1V (370)	SDR VDD 1, 0V 64
L4 N300	S8A	0.928V (126)	QLINK, EBI, MIPI 39
L5 MVP50	VPH	2.96V (22)	PX 113
L6 N1200	S5A	0.624V (1040)	VDDQ, EBI 9
L7 N600	S6A	0.928V (54.2)	USB 49
L8 N300	S5A	0.664V (81)	CX 33
L9 LVP600	STA	1.8V (754)	Sensors, WCD, TMD, PMI_MSM, QET 43
L10 LVP150	STA	1.8V (100)	QFPROM, USB, UFS, PX 81
L11 LVP600	STA	1.8V (925)	EMMC/VCCQ 45
L12 LVP300	STA	1.8V (121)	OV_USB_REDRIIVER 69
L13 LVP300	STA	1.8V (204)	QPM 1.8V, BBRX, GPS 105
L14 LVP600	STA	1.8V (650)	WCD Buck 94, 93
L15 MVP150	VPH	3.128V (5.28)	USB 3.1V, DP PHY 114
L16 LVP150	STA	1.8V (92.5)	WCSS, WCN_XO 93
L17 N300	S6A	1.304V (246)	WCN, WCSS ADX DAC 38
L18 N300	S6A	1.232V (133)	MIPI, VDDPX 37
L19 MVP150	VPH/BB	1.8V (60.2)	Memory, SN100, PX 126
L20 MVP150	VPH/BB	1.8V (60.2)	Memory, SN100, PX 138
L21 MVP600	VPH/BB	2.704V (0.68)	QAT, DFE, RTC, QSW 136
L22 MVP600	VPH/BB	2.96V (800)	MMC 137
L23 MVP600	VPH/BB	3.304V (591)	WCN 3.3V 41
L24 MVP600	VPH/BB	2.96V (1170)	EMMC 31

LDO L5/L9/L10/L11/L12/L13/L14/L15/L16/L19/L20/L21/L22/L23/L24 is the Pseudo-capless LDO, so can dnt CAP in BOM  
 PSEUDO CAPLESS LDOs  
 P-type are pseudo-capless, cap can be at load  
 For CAPLESS LDOs: if decaps on the load side do not  
 add up to LDO spec, then install the cap close to the PMIC

<https://Mobile1Tech.com>

Flash LED SINGLE BOARD

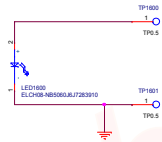

<https://Mobile1Tech.com>

Company Name		
Block Title		
E025888		
Project	J195_MB_V1	Rev 1.0
Date	Friday, August 08, 2008	Sheet 18 of 21



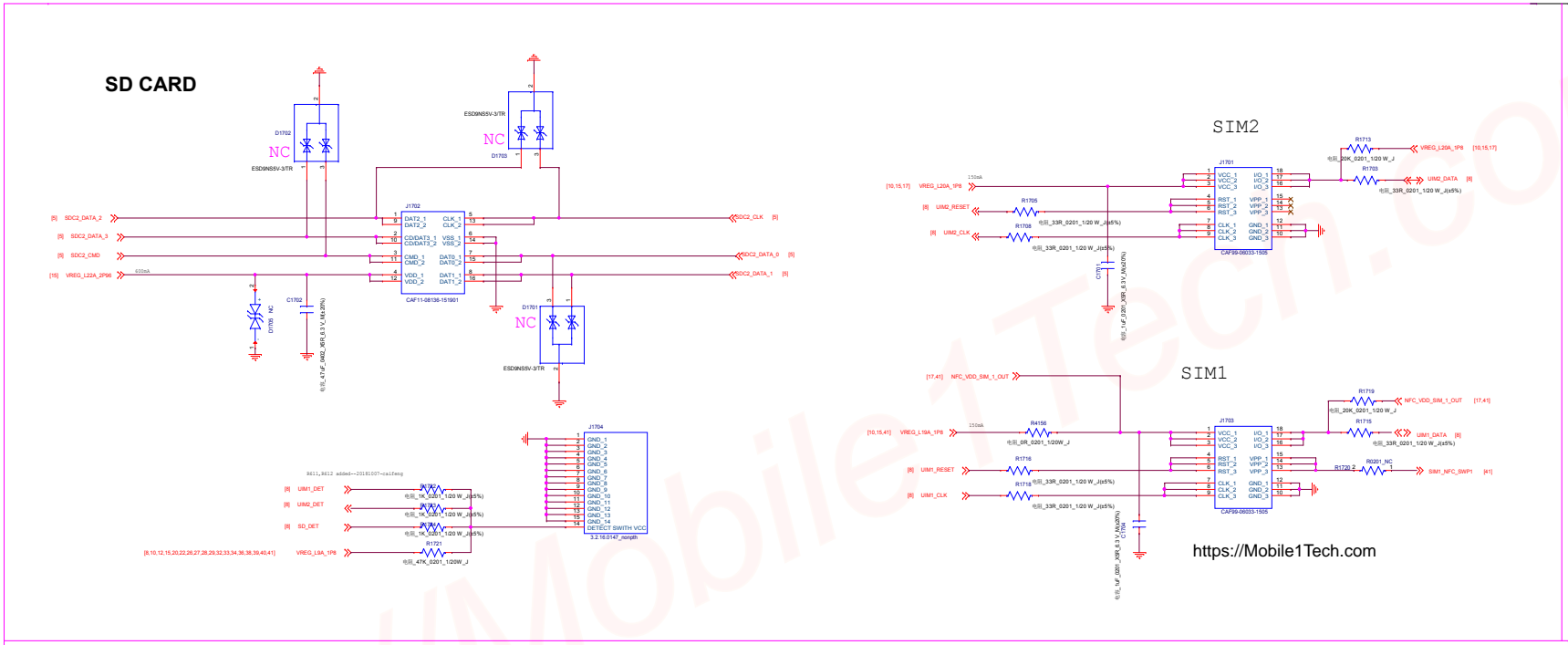

[Schematic design notice of "46\\_MEMORY\\_SD Card" page.](#)

Note 46-1: For better ESD performance, please select suitable components for system protection.

Company Name		
Block Title	SD46M	
Project	J195_M0_V1	Rev 1.0
Date	Friday, August 26, 2016	Sheet 17 of 41

# PMI632 Charger

Ref	Description of device without Register	Description of device with Register
U1004	Push up to 100_CDP with Register	Push 100_CDP
U1012	Push down to 100_VBAT with Register	Push 100_VBAT
U1010	Push down to 100_VBAT with Register	Push 100_VBAT

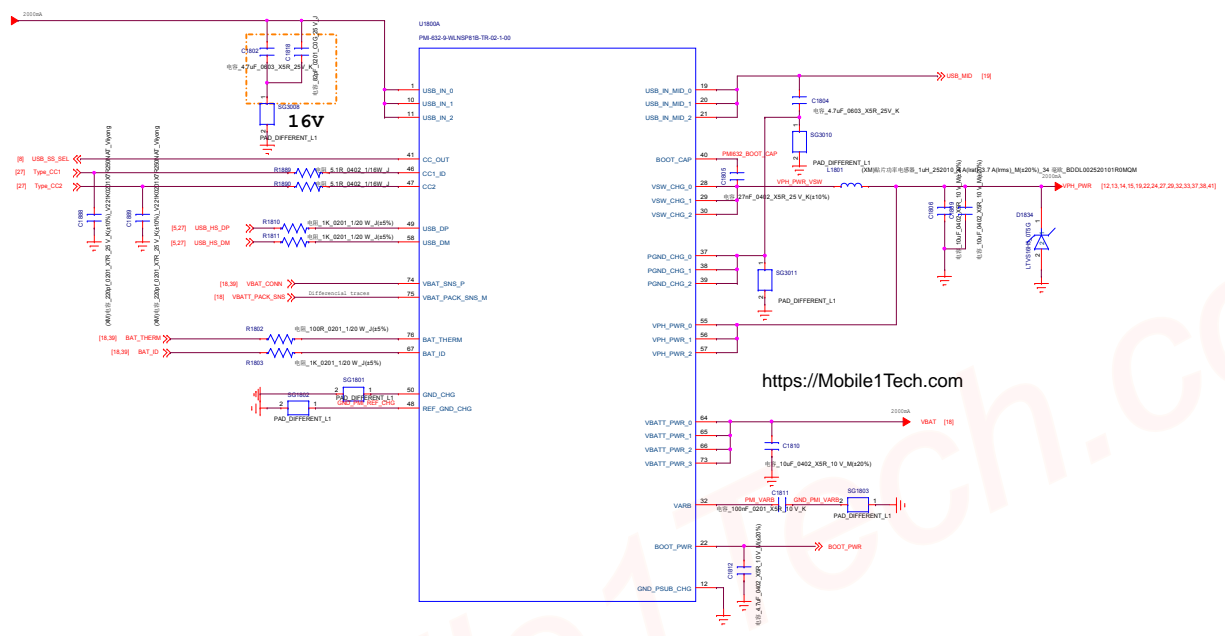

图纸街-让维修更容易!  
https://www.tuzhijie.com

## Battery Connector

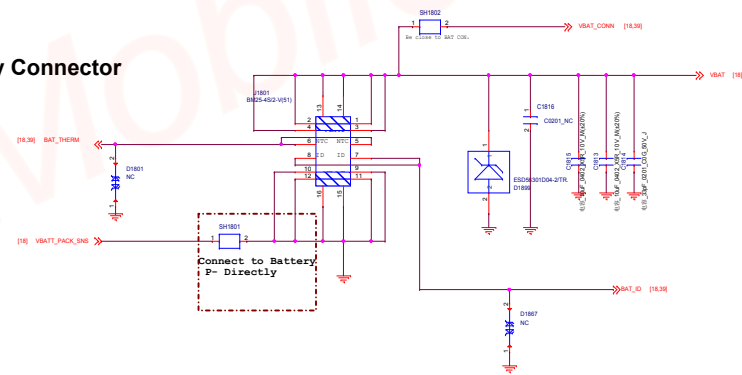

Schematic design notice of "26\_POWER\_SubPMIC-Charger + PP" page.  
Note 26-1: For better ESD or surge performance we need choose suitable device for system protection. Please refer to [Surge device selection guide V2.0] provide by MTK.



# UFS MEMORY

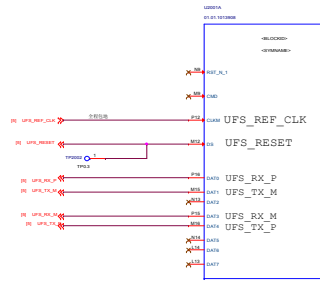

# uMCP: LPDDR4x

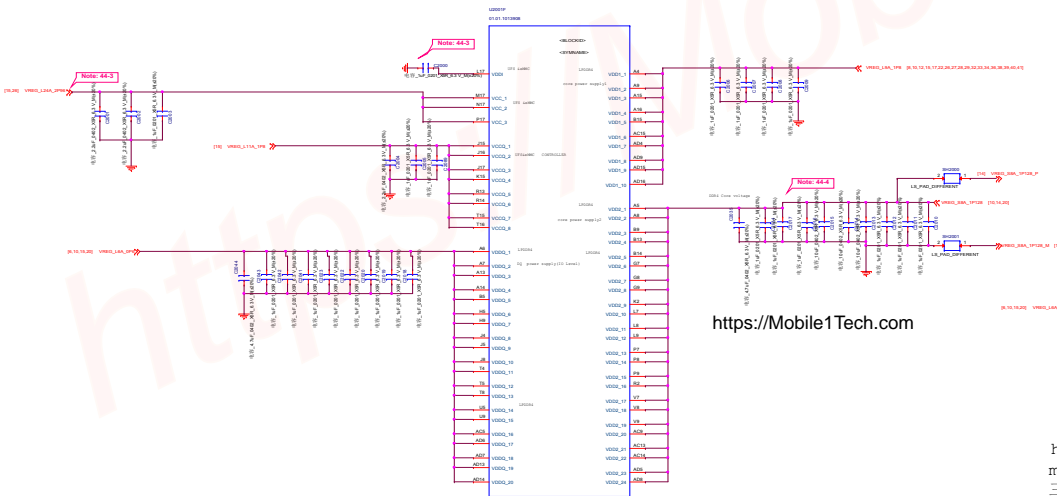
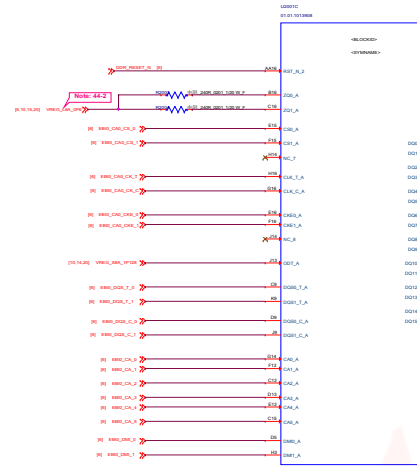

<https://Mobile1Tech.com>

hynix是0.22uF, 最大不超过1uF, micron是1uF, 三星的不需要贴。但是为了避免项目使用几家的uMCP时bom出错, 统一贴1uF

### Charger\_THERMAL

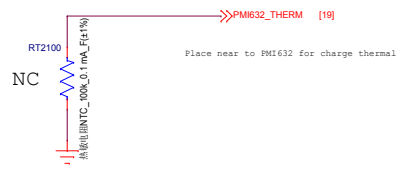

### QUIET\_THERM



Company: Huaqin	
Block Title: NTC	
Project: J19S_MB_V1	Rev: 1.0
Date: Friday, August 28, 2020	Sheet: 21 of 41

### WCD9370

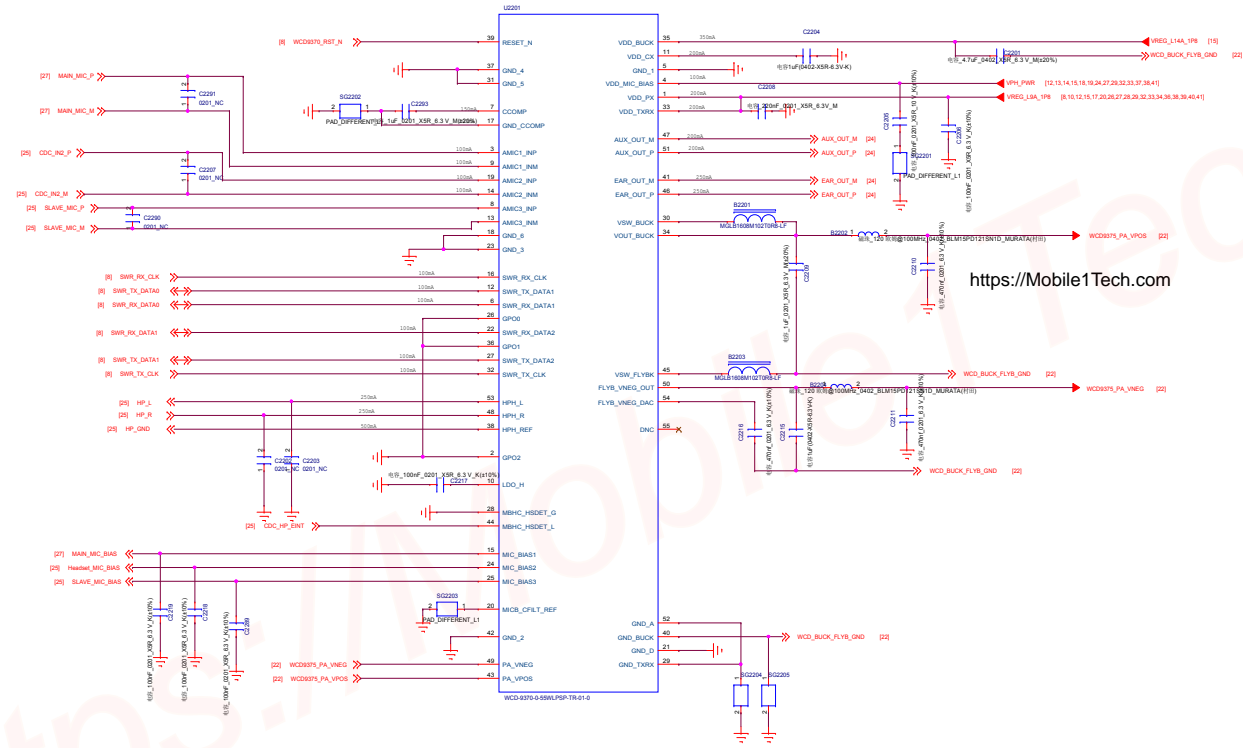

Power Key => PWRKEY + GND  
Volume Up => COL0 + GND (Download Key)  
Volume Down => FCHR\_ENB + GND  
www.tuzhijie.com 图纸街

DO NOT put pull-up resistor on PWRKEY

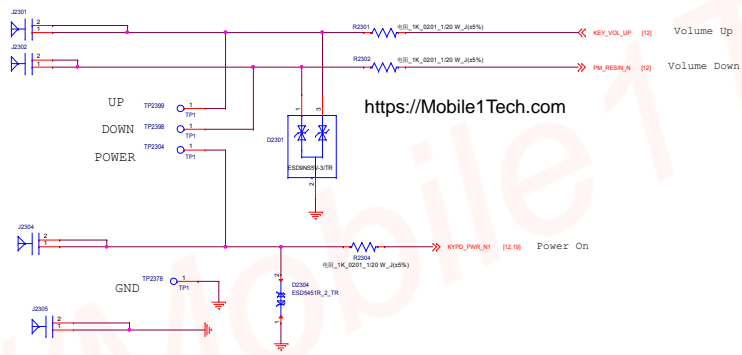

TP/GND/Shielding

Company Name	
Block Title	Test Points
Project	J195_AB_V1
Date	Friday, August 08, 2003
Rev	1.0
Sheet	33 of 41

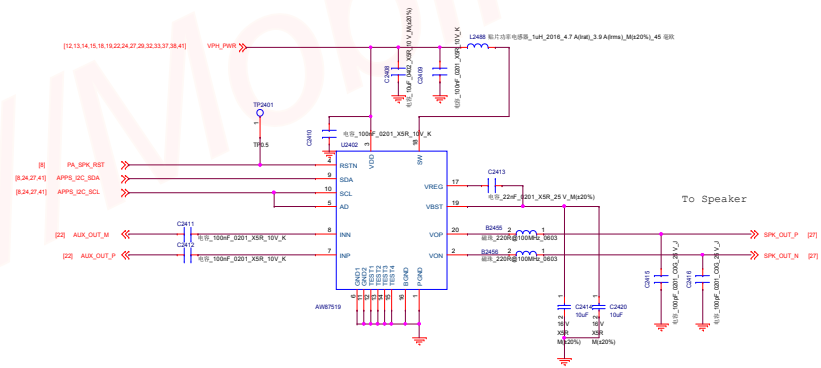
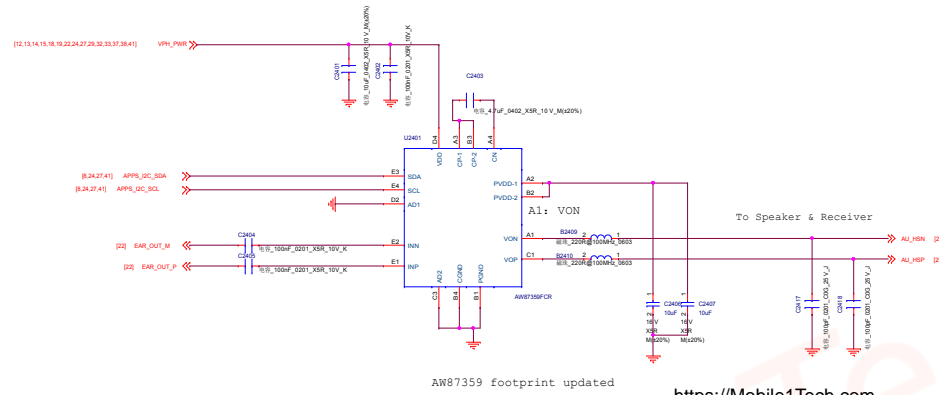

Company Name	
Block Title	AUXIO_Driver_SPK
Project	J195_MB_V1
Date	Friday, August 28, 2020
Rev	1.0
Sheet	25 of 41



# Earphone Microphone

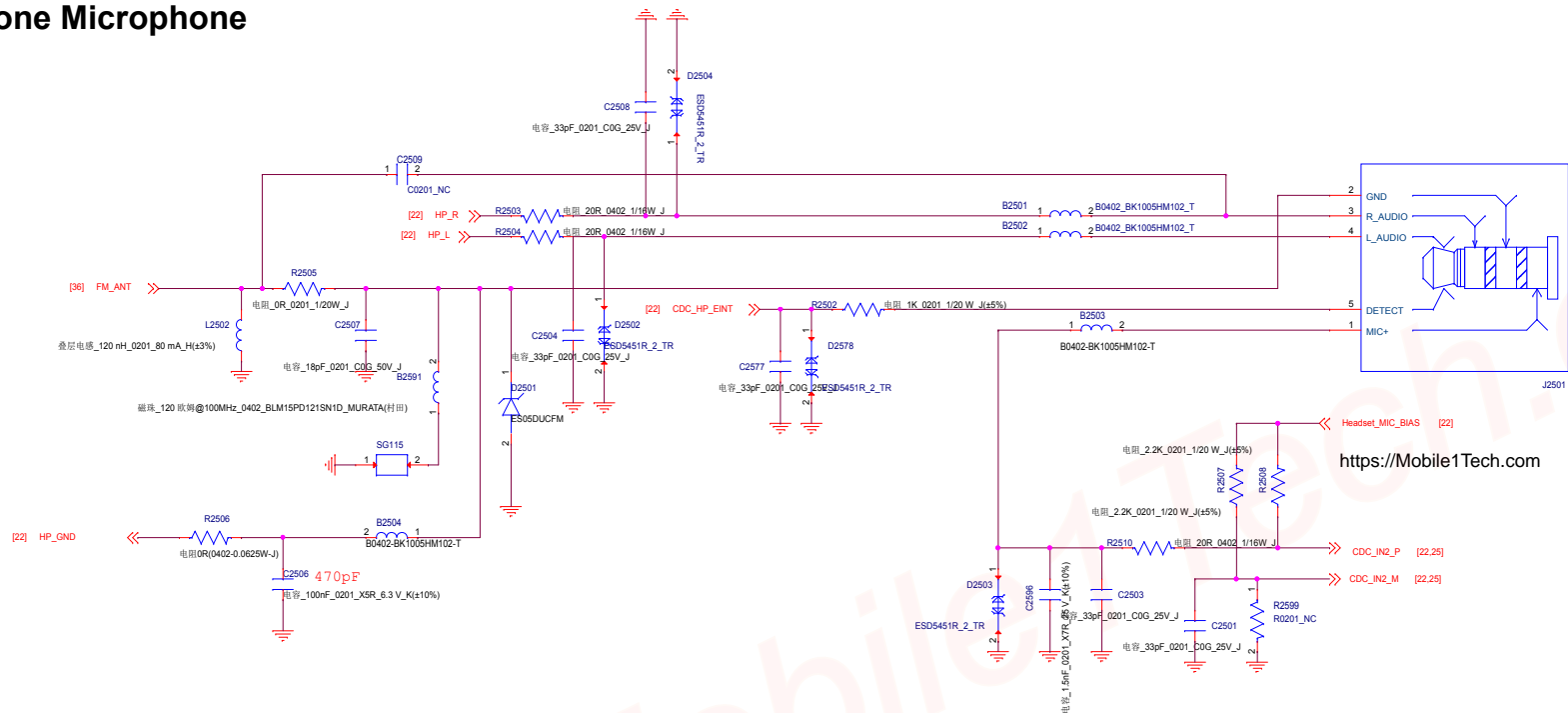

# Receiver

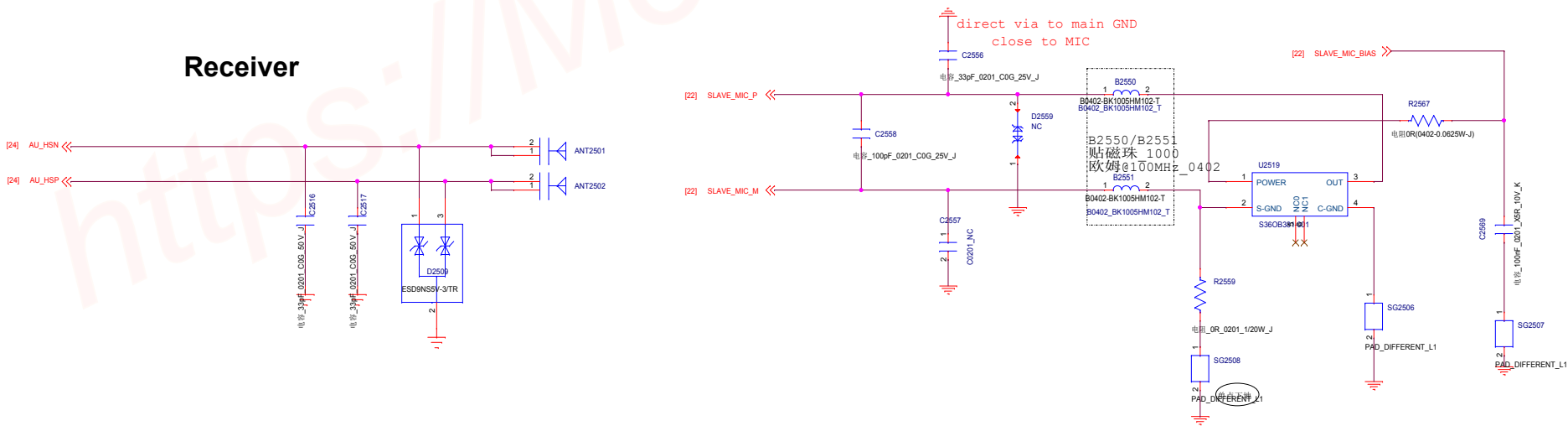

# M-Sensor

AK09918 / M-Sensor I2C Address : 0x0C (Write:0x18, Read:0x19)

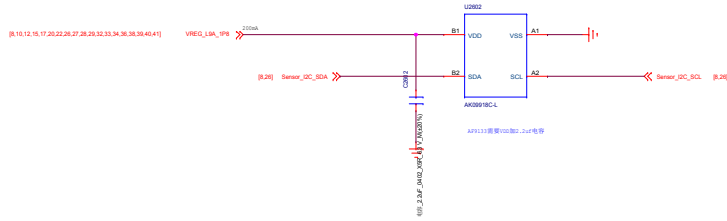

# ALS SENSOR

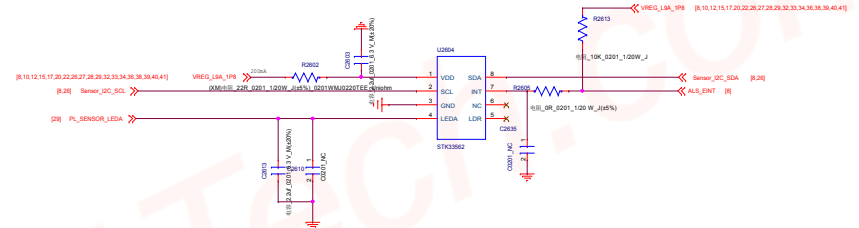

Q10: sensor 6 引脚没打丝印，不通用 I2C 地址 0x0C (W: 0x18, R: 0x19)  
 1: 引脚没打丝印，丝印与图不符，请对 I2C 地址 0x0C，并核对图不  
 2: 引脚没打丝印，丝印与图不符，请对 I2C 地址 0x0C，并核对图不  
 3: 引脚没打丝印，丝印与图不符，请对 I2C 地址 0x0C，并核对图不

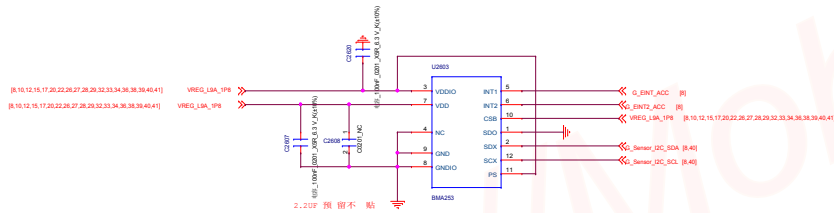

<https://Mobile1Tech.com>

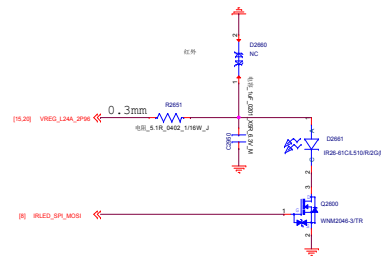

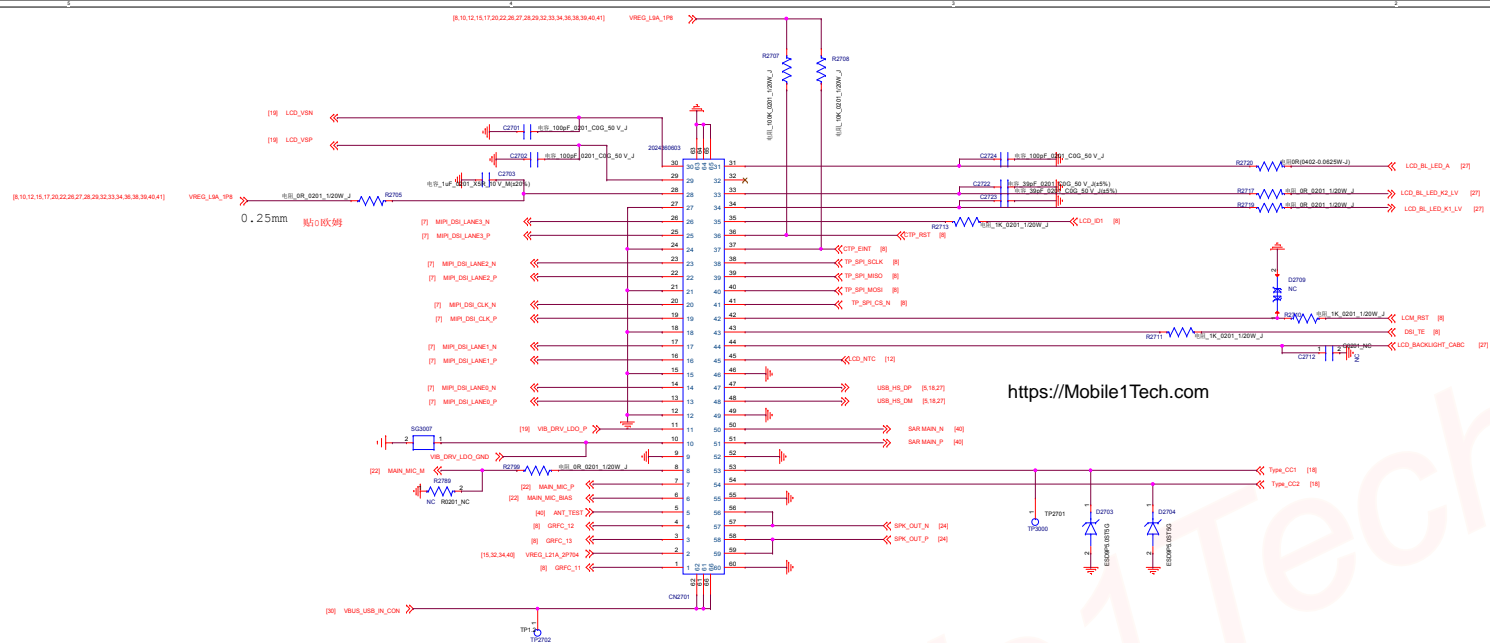

### LCM Backlight LED Driver

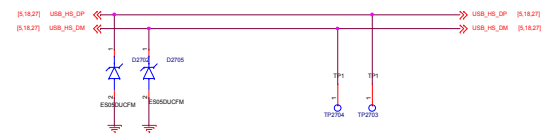
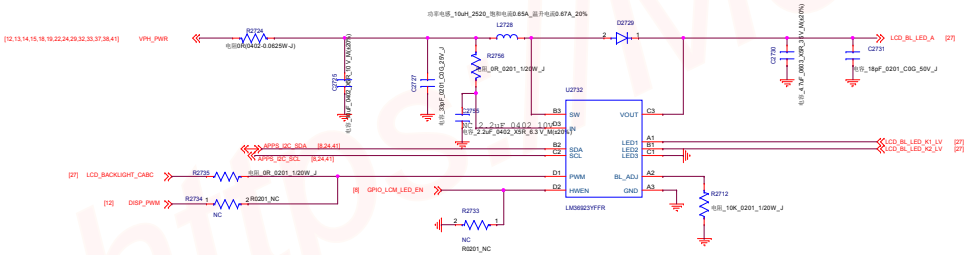

1	00 ADDRESS
100107	010110 binary (see 365)
100110	010111 binary (see 365)









# MMMB PA

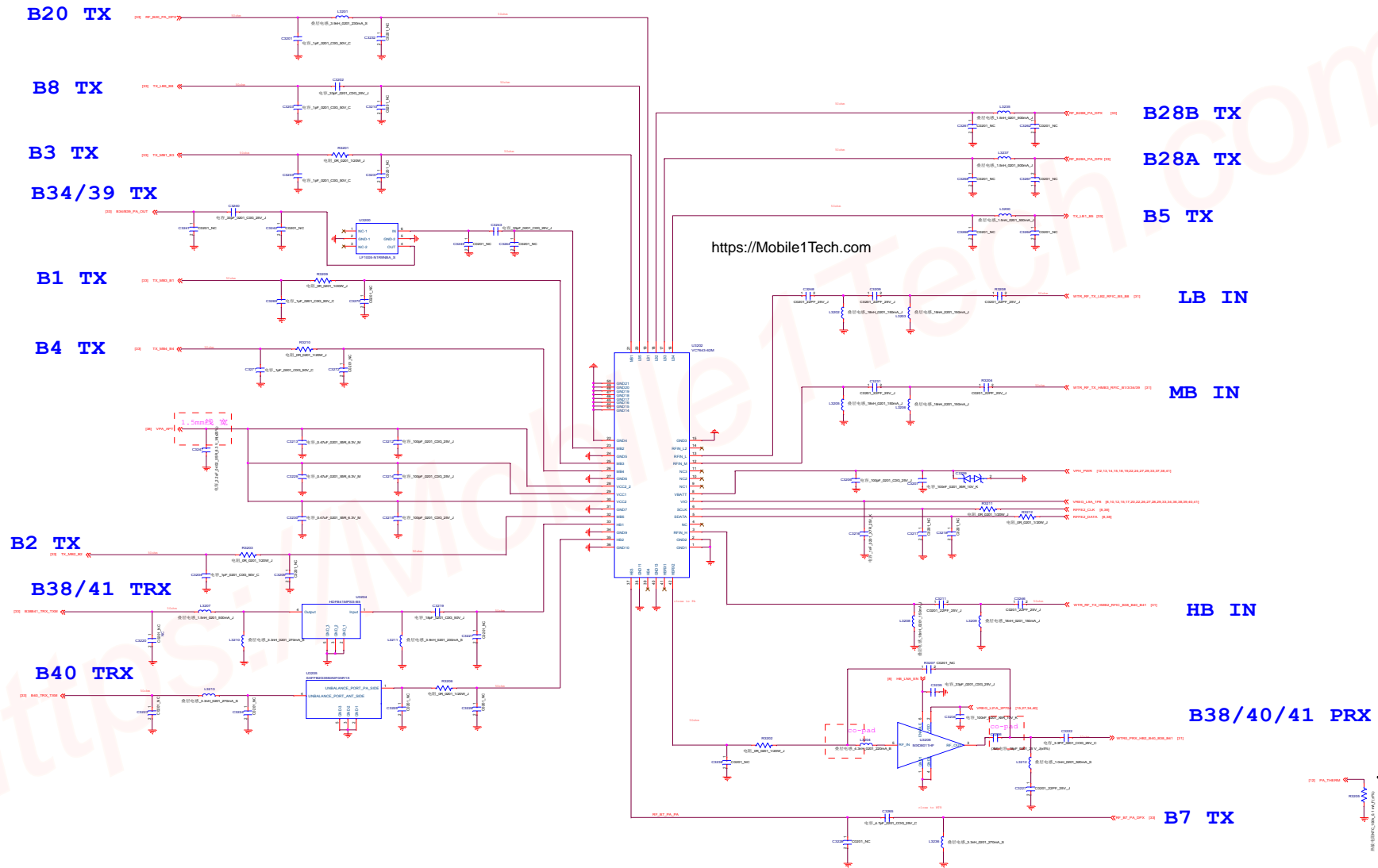

华勤通讯 Huaqin Telecom Technology Com., Ltd		
Title 32_RF_MT6177_RF_TX		
Size E	Project SM4250_MB_V1	Rev v1
Date: Friday, August 28, 2020	Sheet 32 of 41	



# TXM

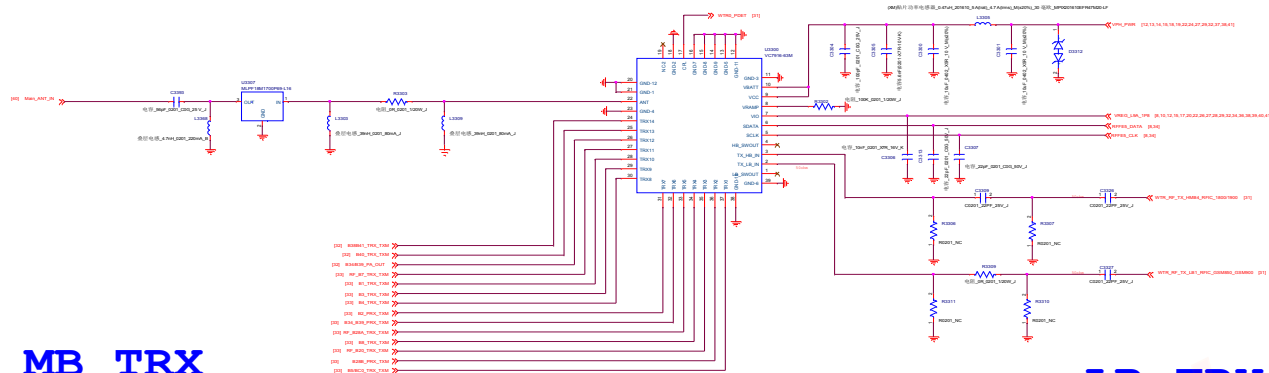

## MB TRX

### B1 TRX

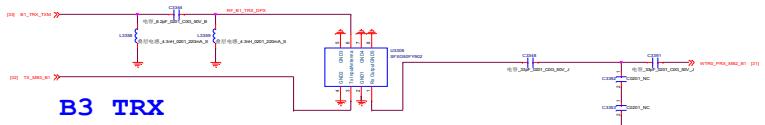

### B3 TRX

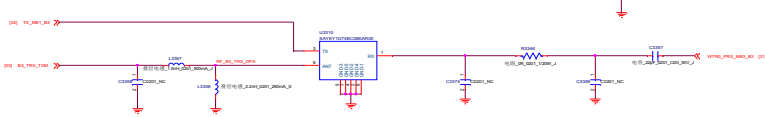

### B2 PRX

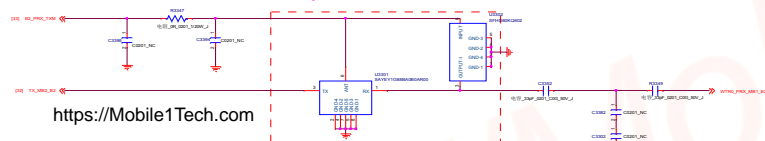

### B34/B39 PRX

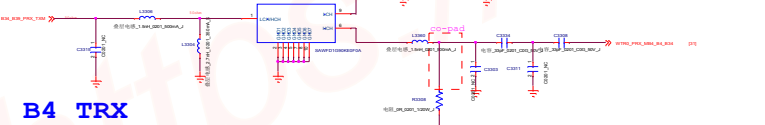

### B4 TRX



### B7 TRX

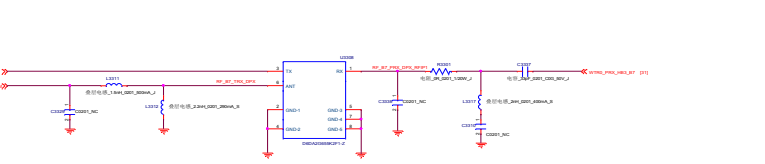

## LB TRX

### B5 TRX

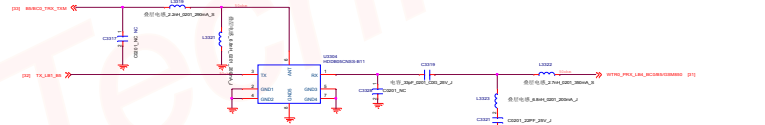

### B8 TRX

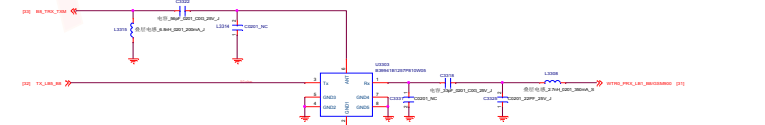

### B20 TRX

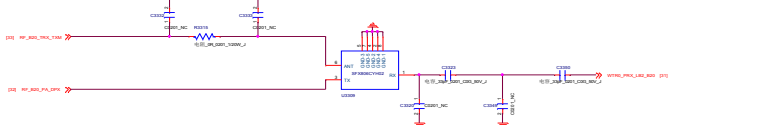

### B28A TRX

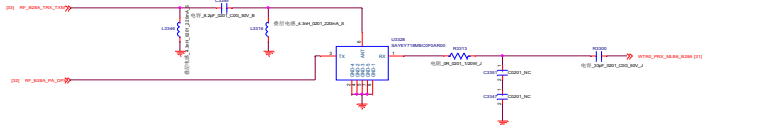

### B28B TRX

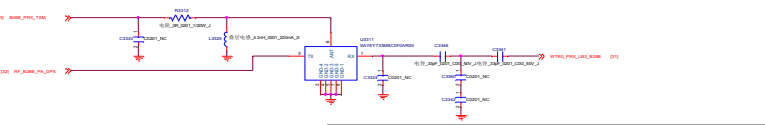

<https://Mobile1Tech.com>

华勤通讯 Huaqin Telecom Technology Com.,Ltd		
Title 33_RF_MT6177_RF_PRX		
Size E	Project SM4250_MB_V1	Rev v1
Date: Friday, August 28, 2020	Sheet 33 of 41	

**DIV\_ANT**

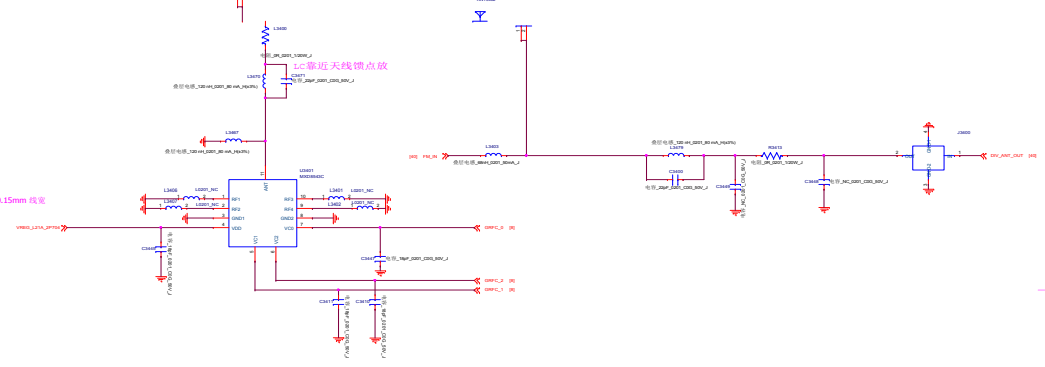

**DRX Switch**

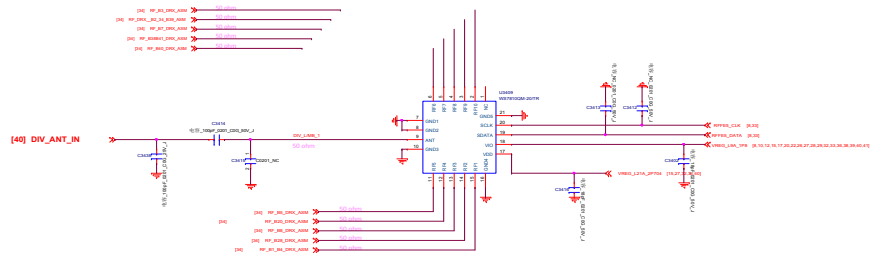

**B2/B34/B39 DRX**

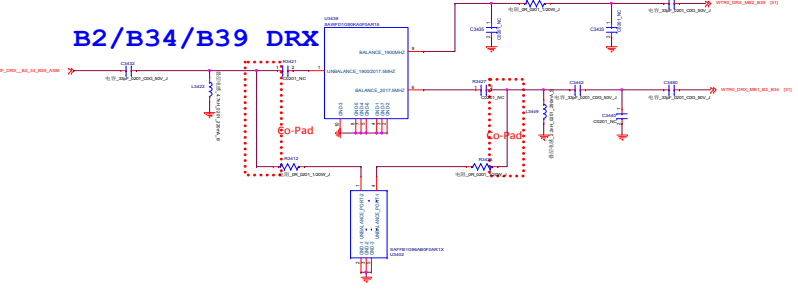

**B8 DRX**



**B5 DRX**



**B28\_DRX**

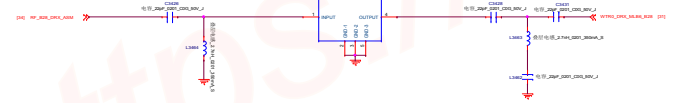

**B20\_DRX**

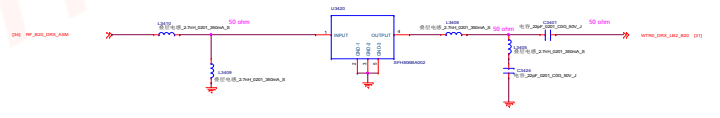

**B3 DRX**

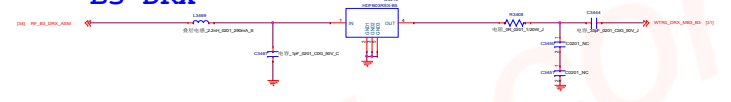

**B1/4 DRX**

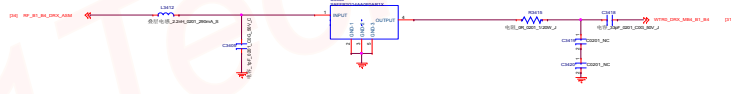

**B7 DRX**



**B40 DRX**



**B38/B41 DRX**

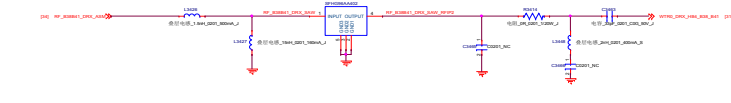

<https://Mobile1Tech.com>

华勤通讯 Huaqin Telecom Technology Com.,Ltd		
Title 34_RF_SDR425_RF_DRX		
Size E	Project J19S_MB_V1	Rev v1
Date: Friday, August 28, 2020	Sheet 34 of 41	

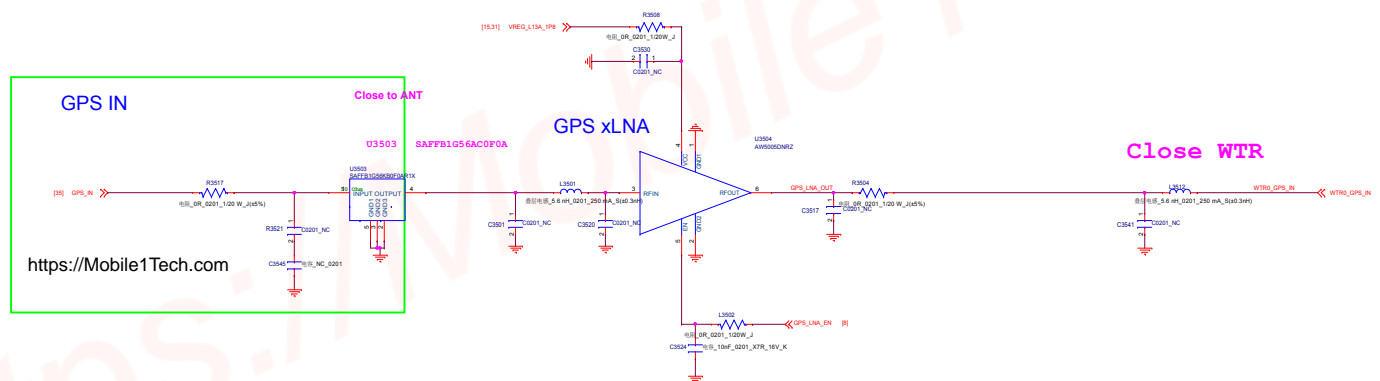
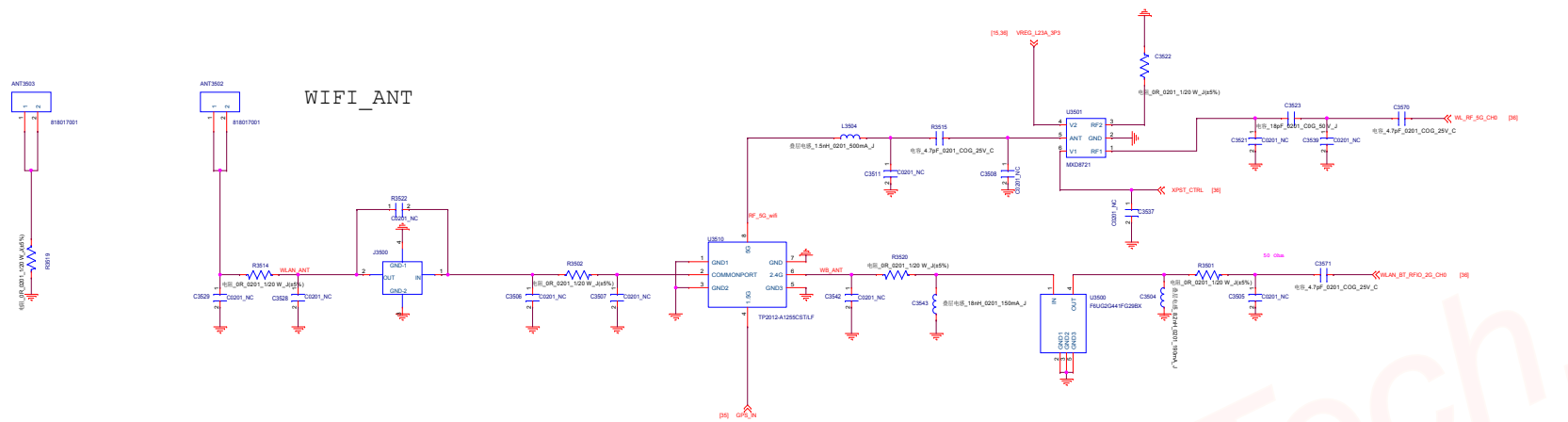

**Schematic design notice of "51\_CONNECTIVITY\_CONSYS\_MT6631"**

- Note 51-1: For R5015 size, please select 0402 size or larger one
- Note 51-2: Please refer to MT6765 Baseband design notice for VCN33 LDO selection guide
- Note 51-3: If WIFI 5G not support, connect pin 34(WF\_RF\_SG) to GND
- Note 51-4: Pin 36 (AVDD28\_FM) must be connected to VCN28 even if FM not support

华勤通讯 Huaqin Telecom Technology Com.,Ltd		
Title 35_CONNECTIVITY_CONSYS_WCN3950		
Size D	Project J19S_MB_V1	Rev V1
Date: Friday, August 28, 2020	Sheet 35 of 41	

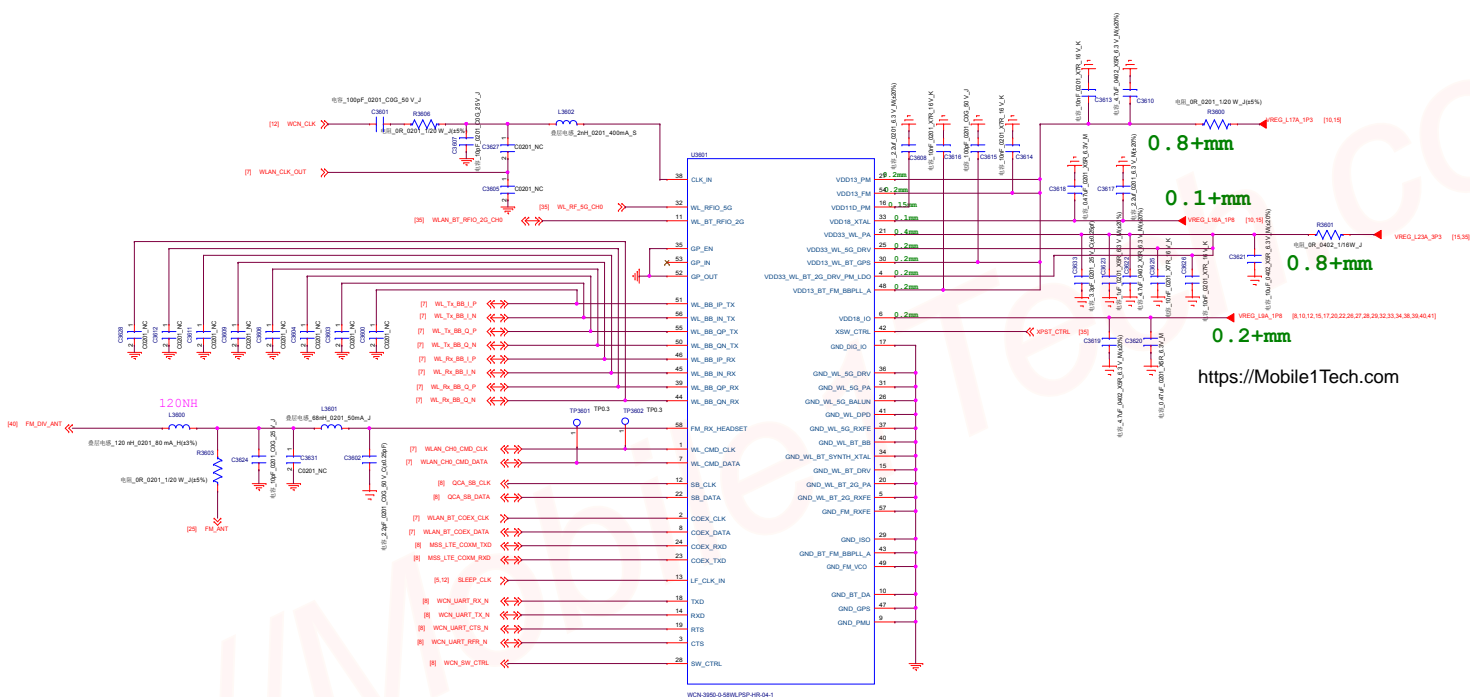

华勤通讯 Huaqin Telecom Technology Com.,Ltd		
Title    35_CONNECTIVITY_CONSYS_WCN3950		
Size D	Project J19S_MB_V1	Rev V1
Date:	Friday, August 28, 2020	Sheet 36 of 41

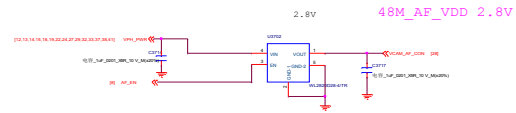
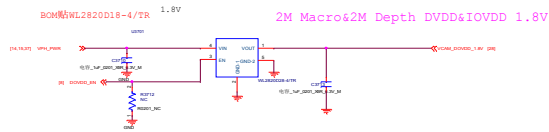

**LDO for Rear Camera (VCAMD\_EXT1)**  
**1.05V**

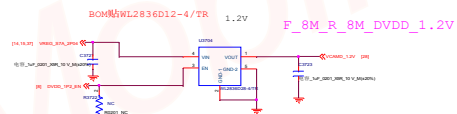
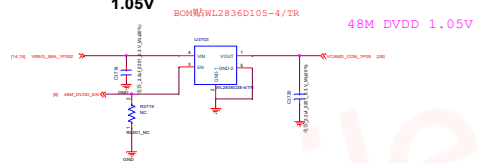

<https://Mobile1Tech.com>

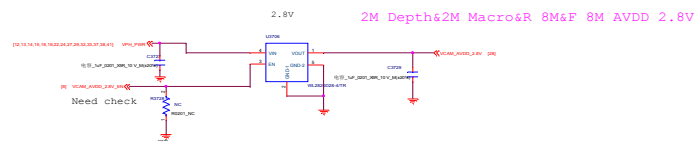
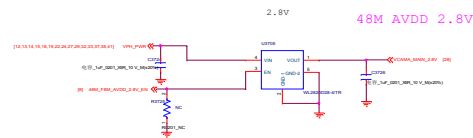

华勤通讯 Huaqin Telecom Technology Com., Ltd		
Title	37_NFC	
Size	Project	Rev
E	J19S_MB_V1	v1
Date:	Friday, August 28, 2020	Sheet 37 of 41

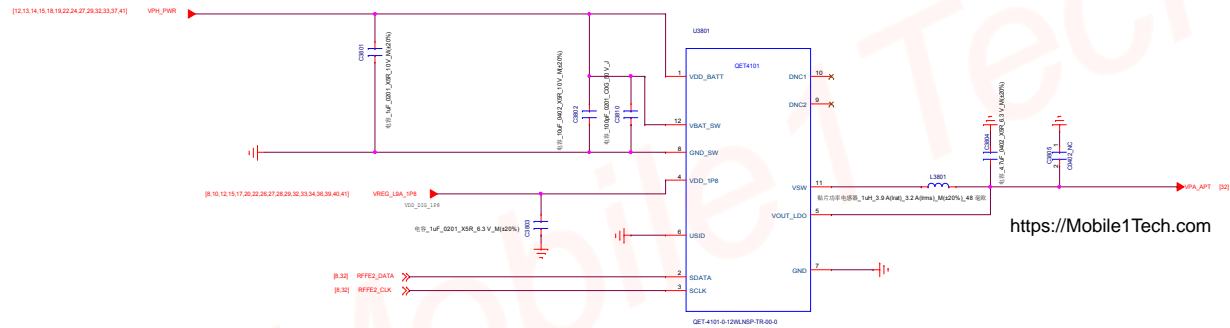

华勤通讯 Huaqin Telecom Technology Com.,Ltd		
Title 38_QET		
Size D	Project J19S_MB_V1	Rev V1
Date: Friday, August 28, 2020	Sheet 38 of 41	

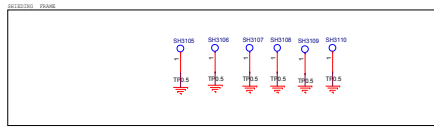

螺丝孔

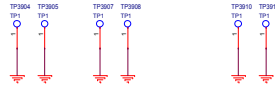

GND

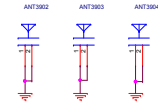

<https://Mobile1Tech.com>

UART DEBUG POINT



VBAT TEST POINT

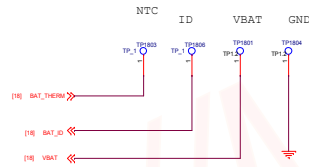

SMT Download Mode

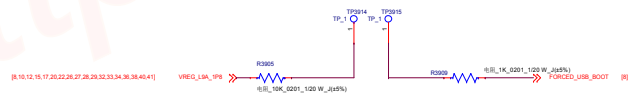

Company Name	
Block Title	Test Points
Project	J192_AB_V1
Date	Friday, August 18, 2006
Rev	1.0
Sheet	33 of 41

同轴座

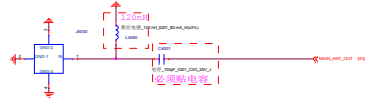

空口检测

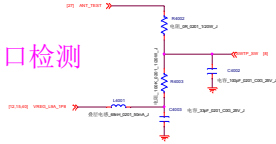

SAR Sensor

Default Address is 0x28 (0x101000)

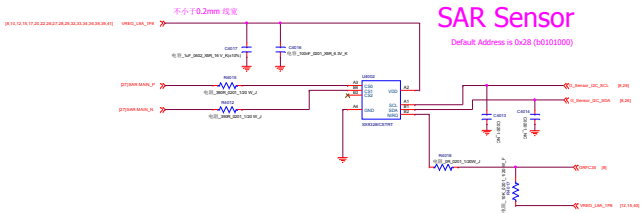

TAS MAIN DPDT SWITCH

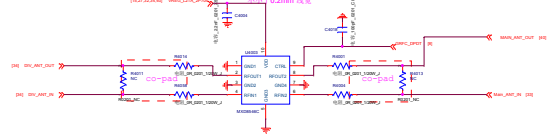

FM LNA

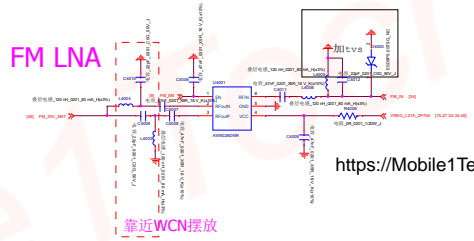

<https://Mobile1Tech.com>



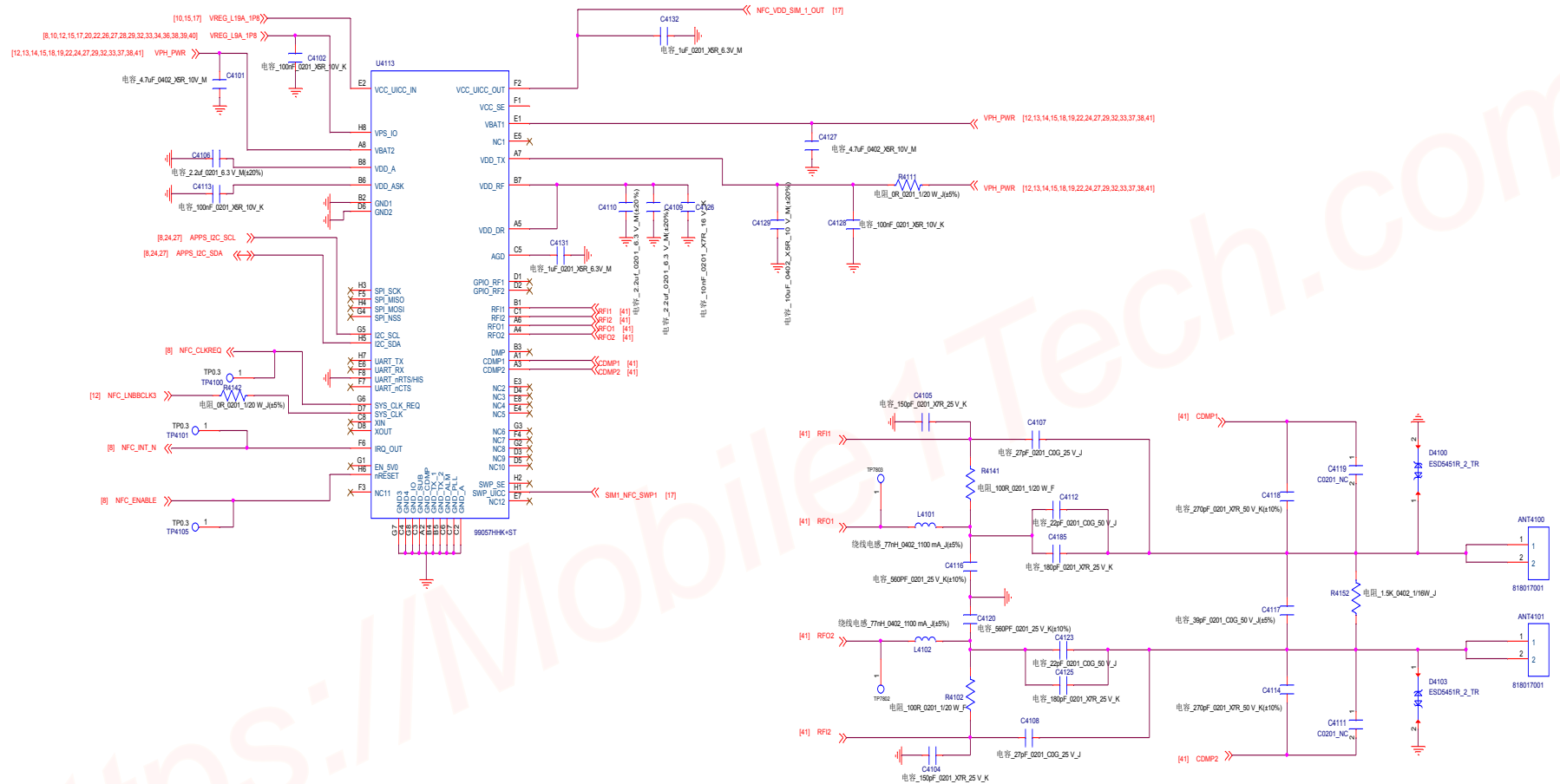

<https://Mobile1Tech.com>

华勤通讯 Huaqin Telecom Technology Com.,Ltd		
Title 41_NFC		
Size E	Project J19S_MB_V1	Rev v1
Date: Friday, August 28, 2020	Sheet 41 of 41	