

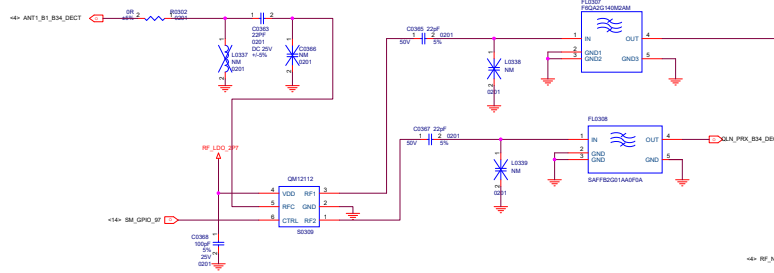

ANT1 B1_B34_DECT

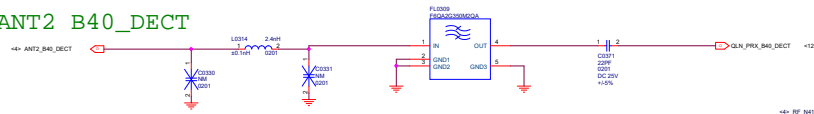

ANT2 B40_DECT



ANT3 N41TRX_N78TRX_N79TRX

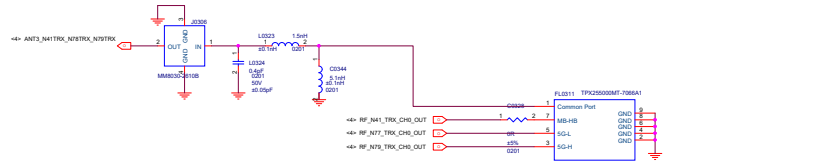

ANT4 LMH

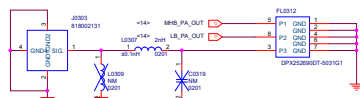

ANT5 LMH DRX

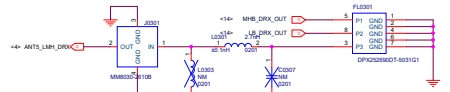

ANT6 N78DRX_N79DRX

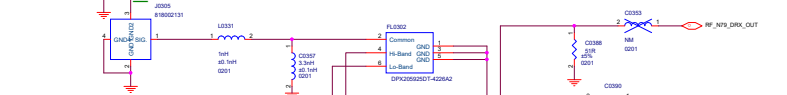

ANT7 N78DRX_M_N79RX_M

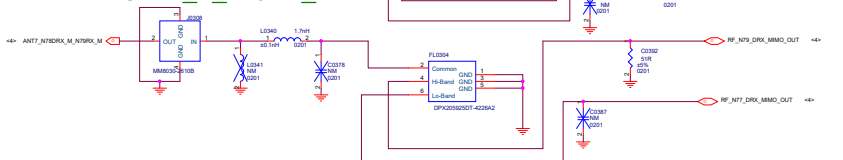

ANT8 N41DRX_N78TRX_N79TRX



N78/77 DPDT3

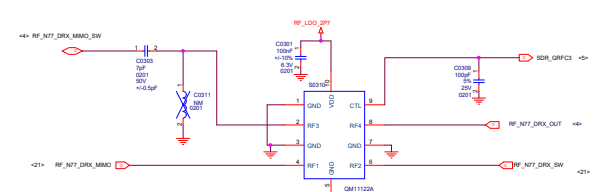

N79 DPDT2

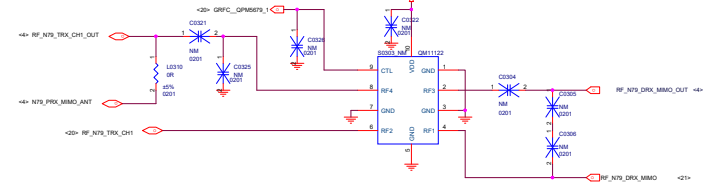

N41 DPDT1

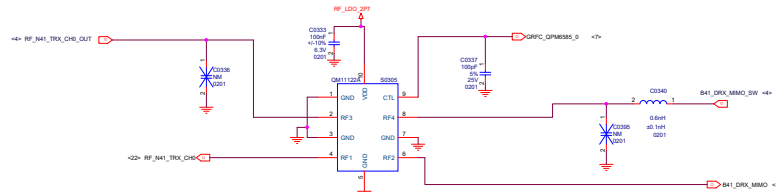

N78/77 DPDT2

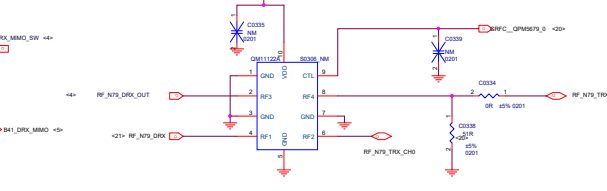

N79 DPDT1

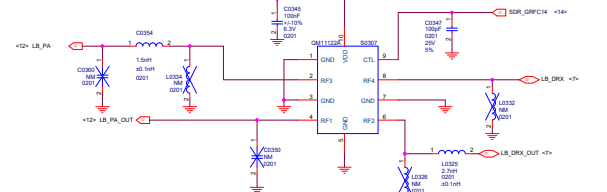

LTE_I DPDT

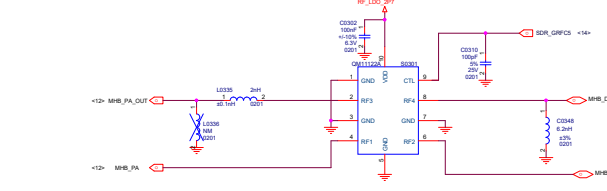

LTE_MH DPDT



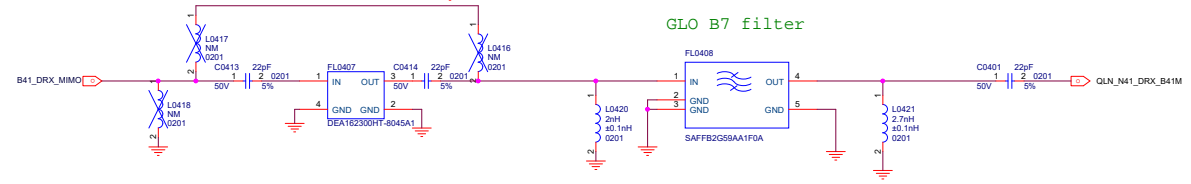
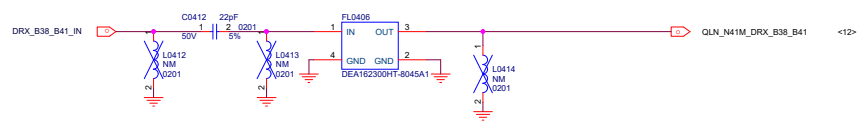
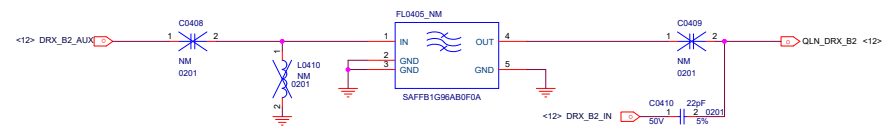
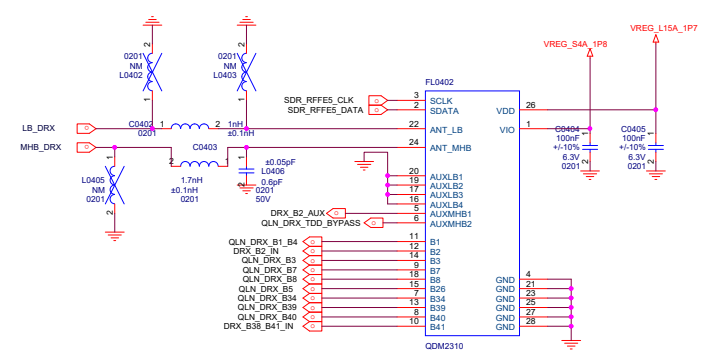

GLO B7 filter

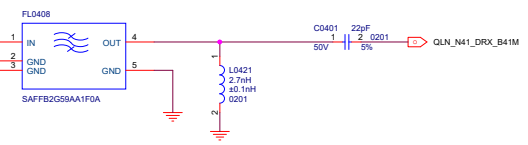

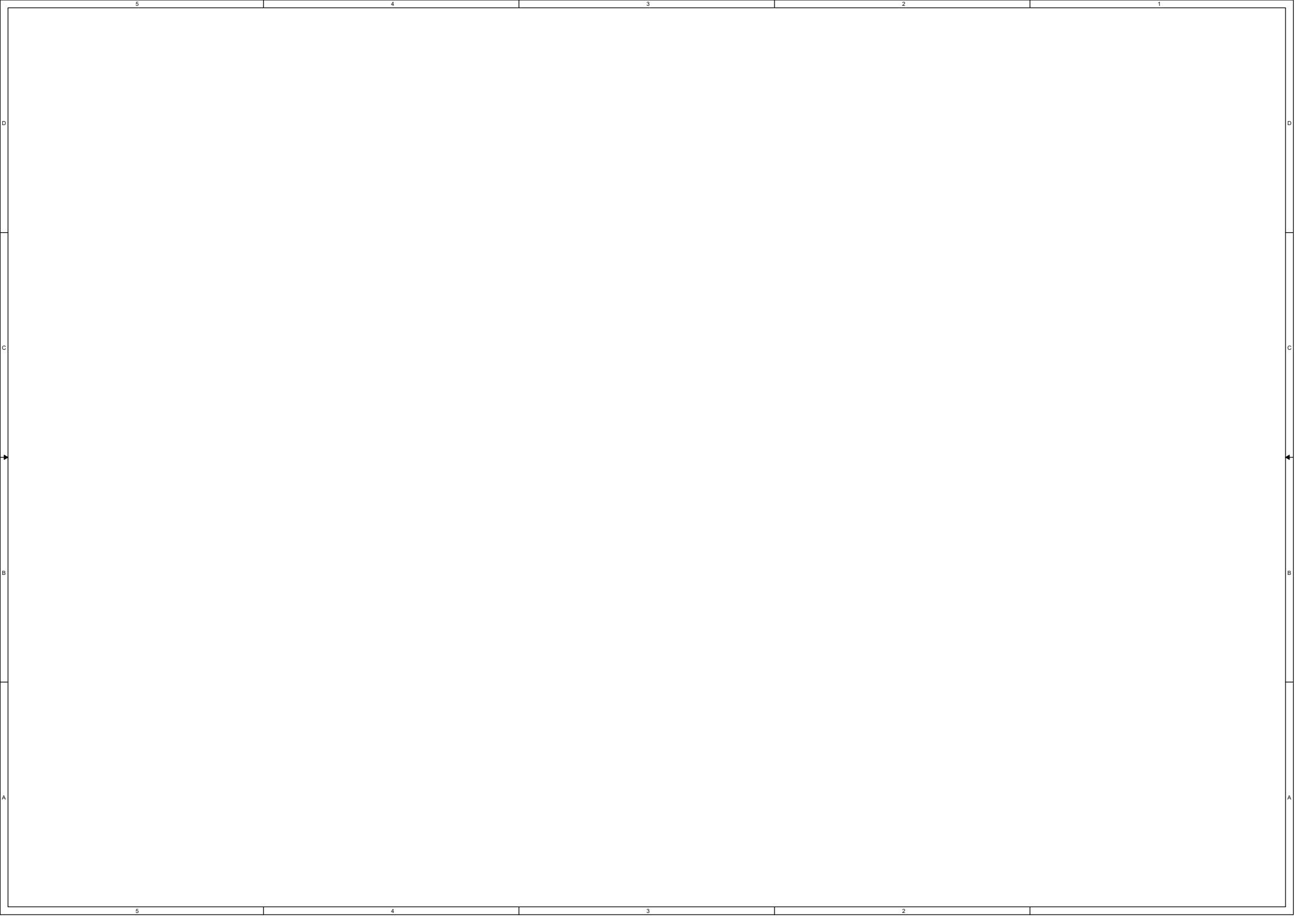

MHB S-PAD

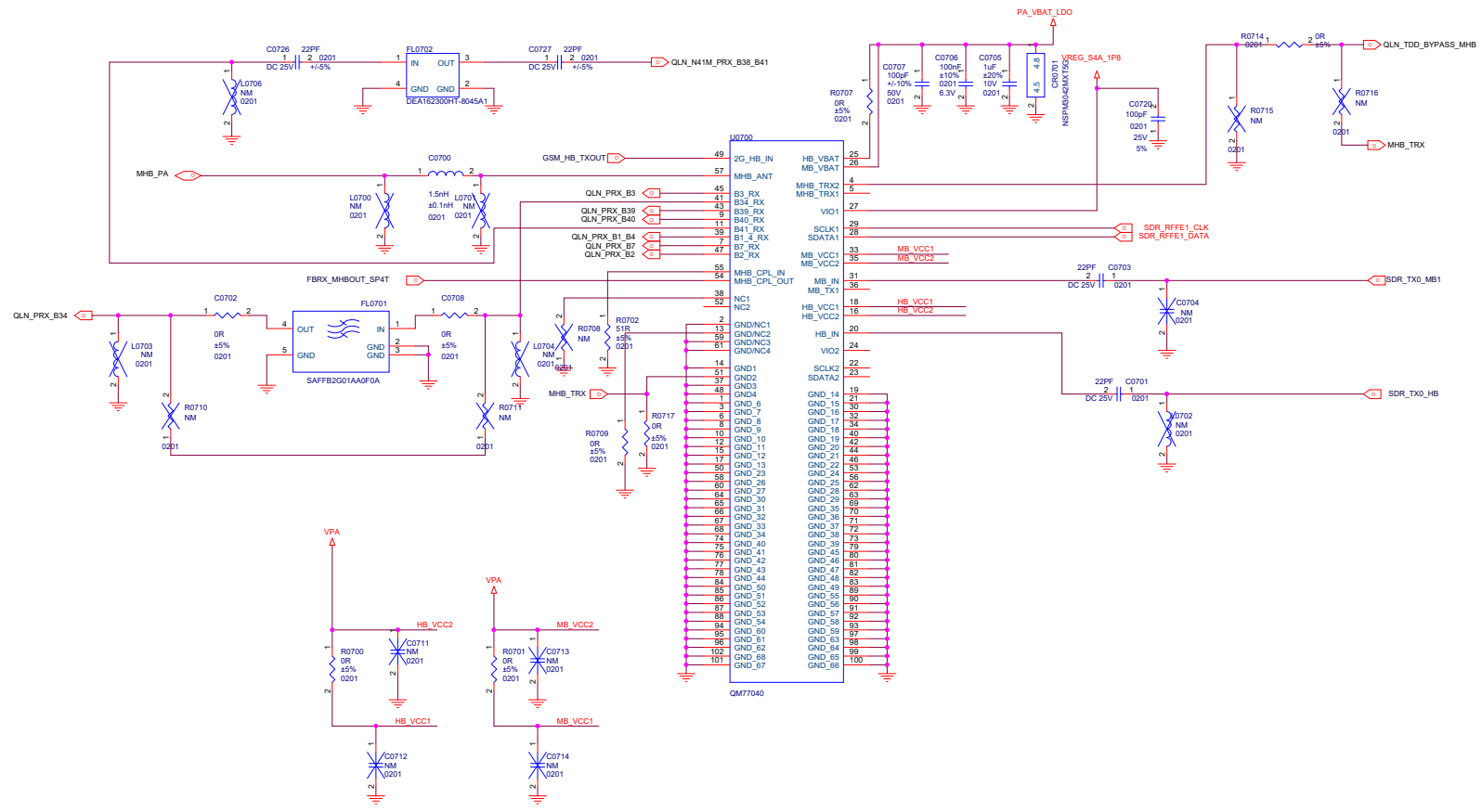

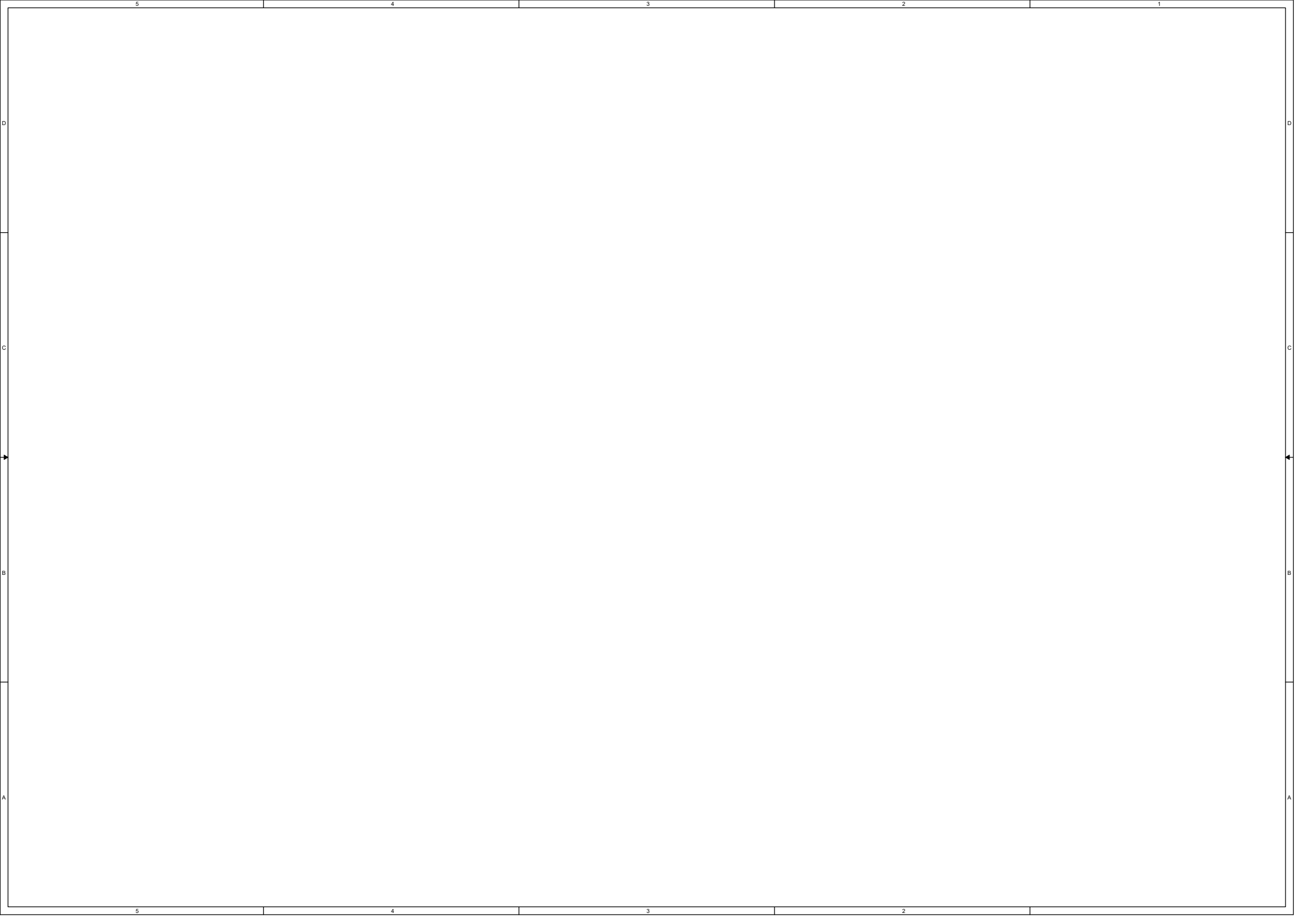

4G QET

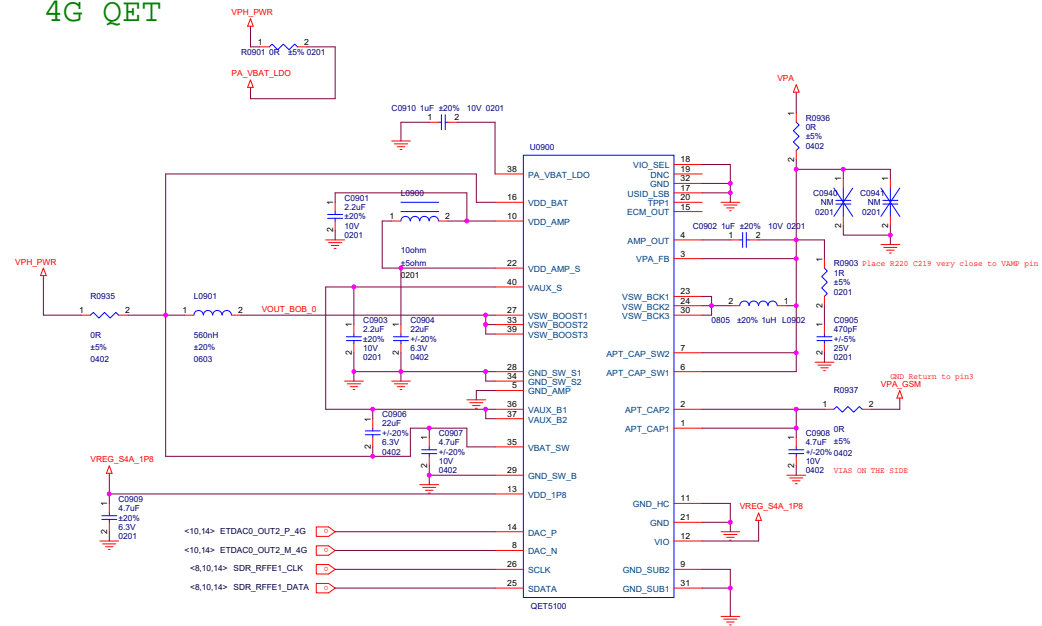

N28 QET

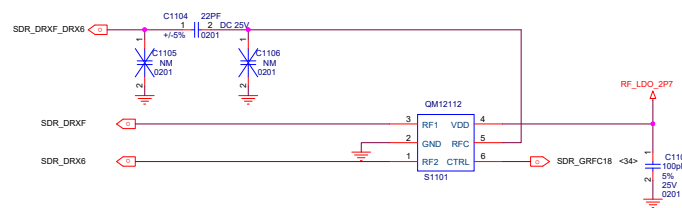
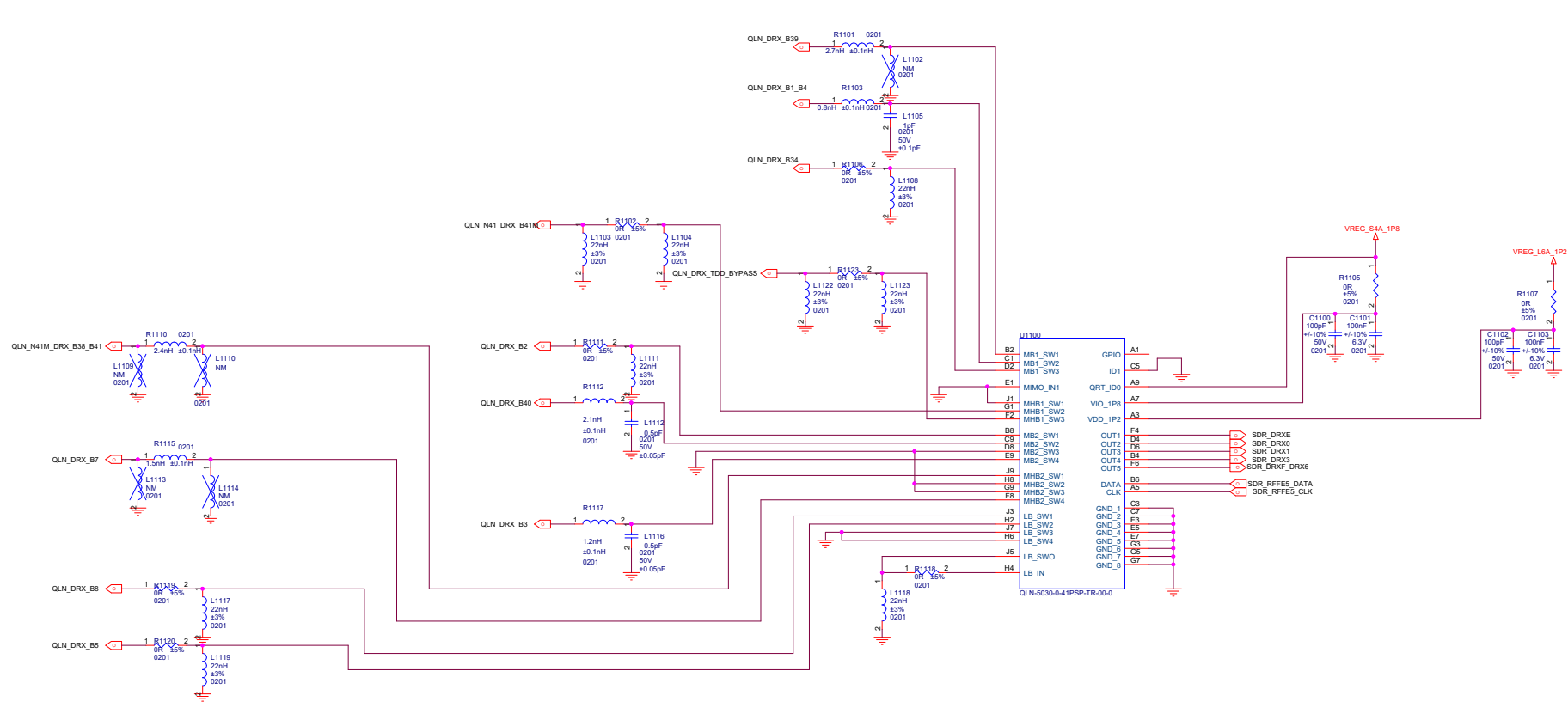

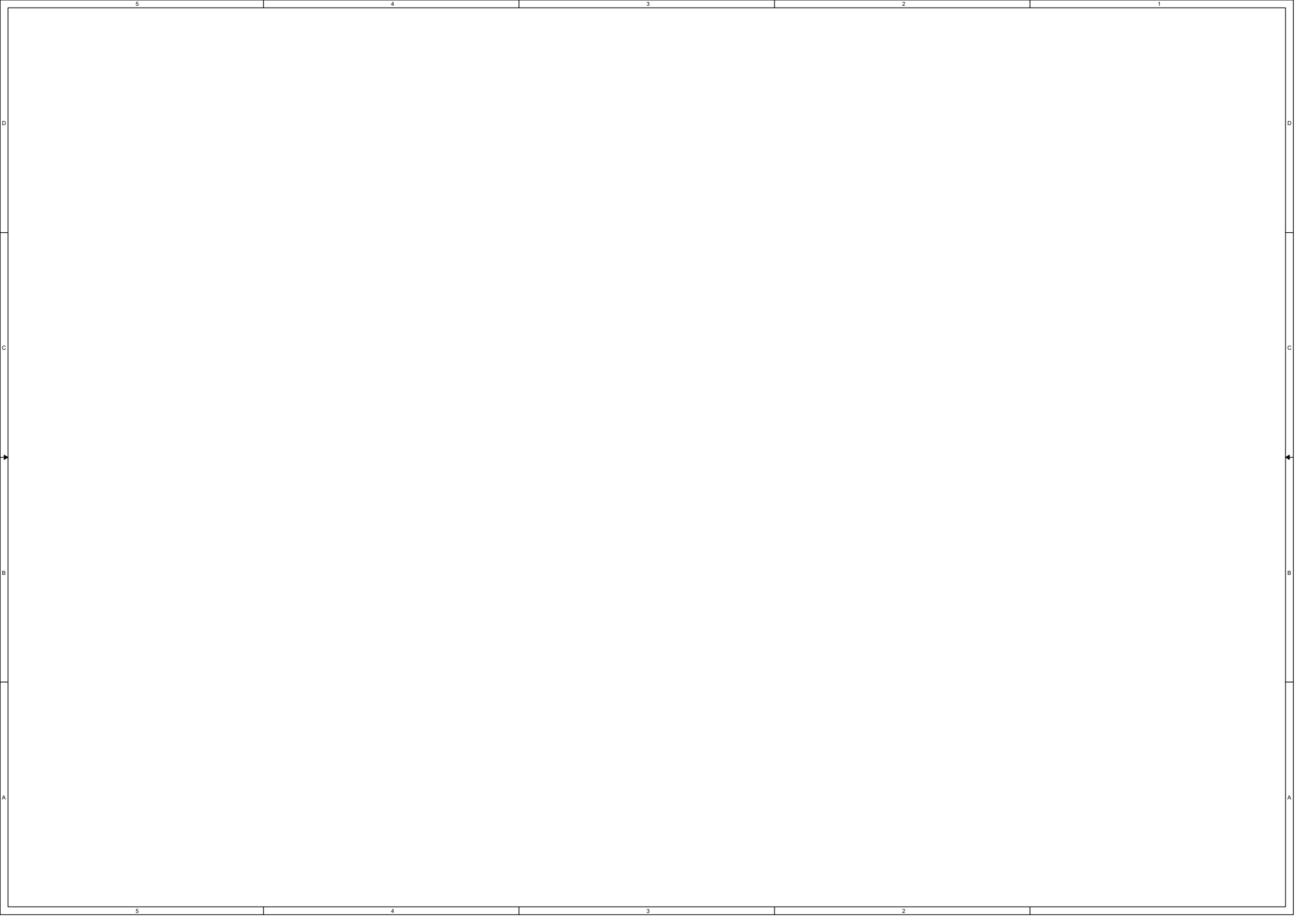

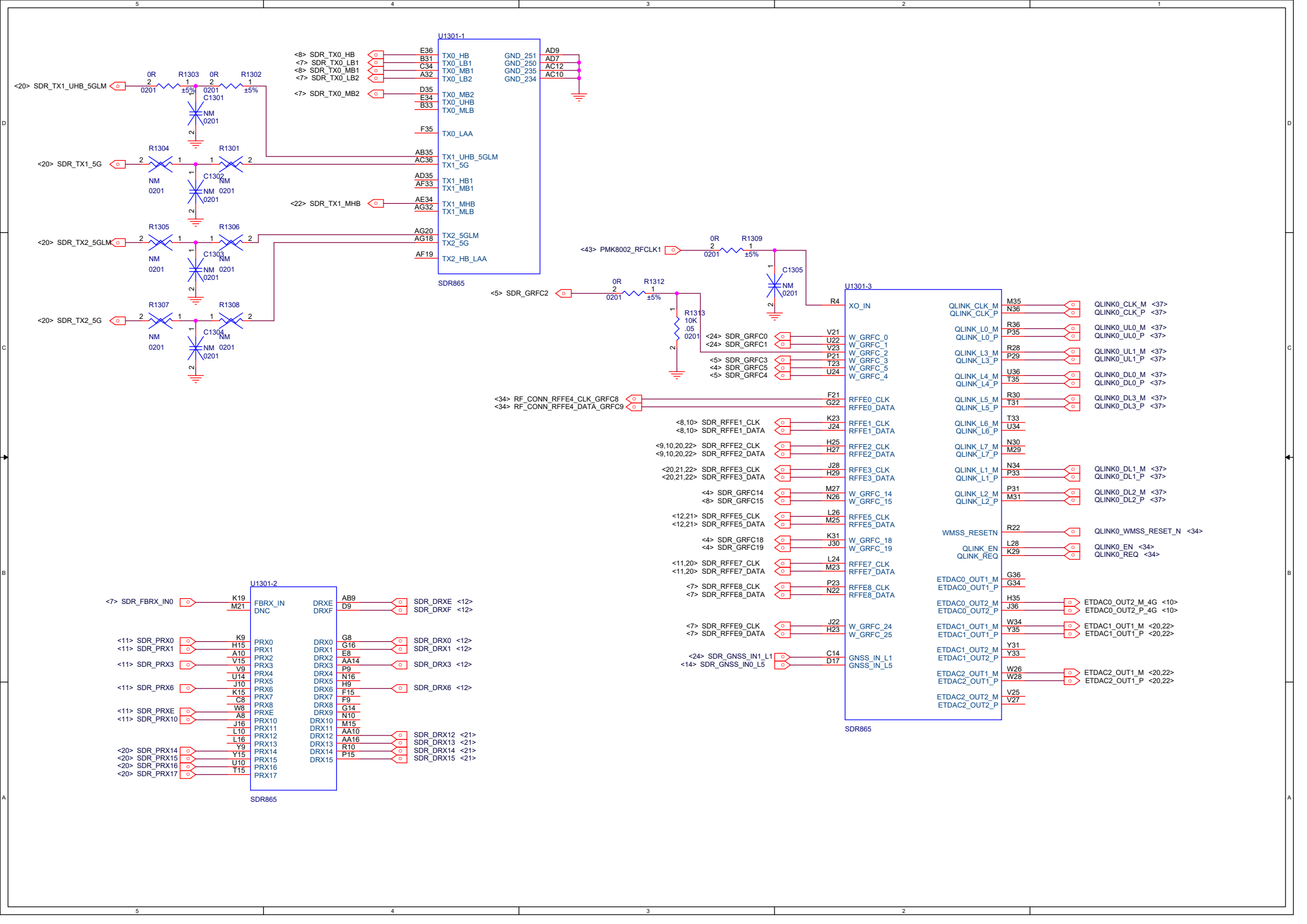

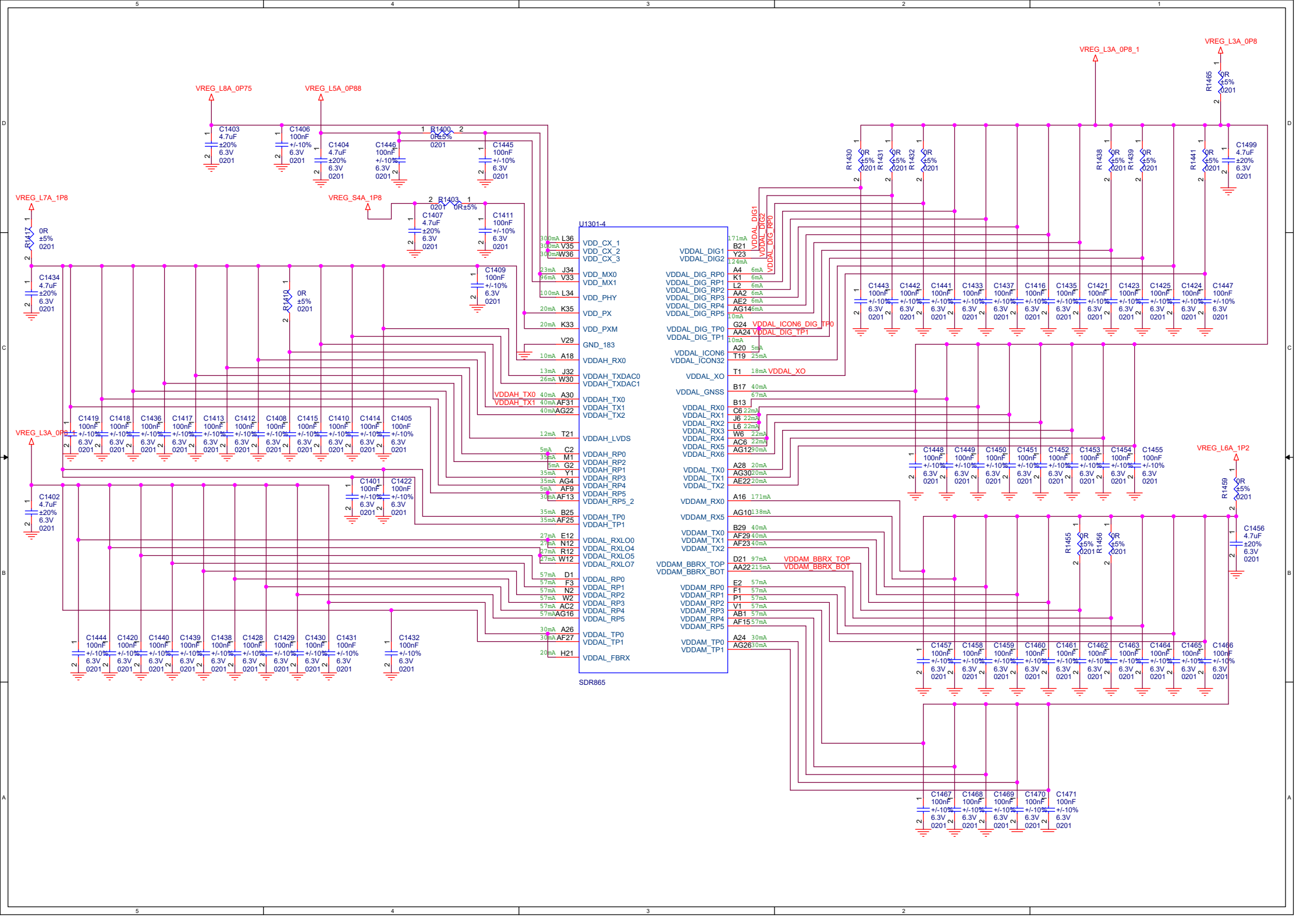

VREG_L8A_0P75

VREG_L5A_0P88

VREG_L7A_1P8

VREG_S4A_1P8

VREG_L3A_0P8

VREG_L6A_1P2

VREG_L3A_0P8_1

VREG_L3A_0P8

U1301.4

30mA L36	VDD_CX_1
30mA V35	VDD_CX_2
30mA W36	VDD_CX_3
83mA J34	VDD_MX0
96mA V33	VDD_MX1
100mA L34	VDD_PHY
20mA K35	VDD_PX
20mA K33	VDD_PXM
V29	GND_183
10mA A18	VDDAH_RX0
13mA J32	VDDAH_TXDAC0
26mA W30	VDDAH_TXDAC1
VDDAH_TX0 40mA A30	VDDAH_TX0
VDDAH_TX1 40mA AF31	VDDAH_TX1
VDDAH_TX2 40mA AG22	VDDAH_TX2
12mA T21	VDDAH_LVDS
5mA C2	VDDAH_RP0
35mA M1	VDDAH_RP2
5mA G2	VDDAH_RP1
35mA Y1	VDDAH_RP3
35mA AG4	VDDAH_RP4
5mA AF9	VDDAH_RP5
30mA AF13	VDDAH_RP5_2
35mA B25	VDDAH_TP0
35mA AF25	VDDAH_TP1
27mA E12	VDDAL_RXL00
27mA N12	VDDAL_RXL04
27mA R12	VDDAL_RXL05
27mA W12	VDDAL_RXL07
57mA D1	VDDAL_RP0
57mA F3	VDDAL_RP1
57mA N2	VDDAL_RP2
57mA W2	VDDAL_RP3
57mA AC2	VDDAL_RP4
57mA AG16	VDDAL_RP5
30mA A26	VDDAL_TP0
30mA AF27	VDDAL_TP1
20mA H21	VDDAL_FBRX

SDR865

VDDAL_DIG1	171mA
VDDAL_DIG2	124mA
VDDAL_DIG_PP0	124mA
VDDAL_RX0	6mA
VDDAL_RX1	6mA
VDDAL_RX2	6mA
VDDAL_RX3	6mA
VDDAL_RX4	6mA
VDDAL_RX5	6mA
VDDAL_RX6	6mA
VDDAL_TX0	20mA
VDDAL_TX1	30mA
VDDAL_TX2	20mA
VDDAM_RX0	171mA
VDDAM_RX5	171mA
VDDAM_TX0	40mA
VDDAM_TX1	40mA
VDDAM_TX2	40mA
VDDAM_BBRX_TOP	97mA
VDDAM_BBRX_BOT	215mA
E2	57mA
F1	57mA
P1	57mA
V1	57mA
AB1	57mA
AF15	57mA
A24	30mA
AG26	30mA

C1443	100nF	+/-10%	6.3V	0201
C1442	100nF	+/-10%	6.3V	0201
C1441	100nF	+/-10%	6.3V	0201
C1433	100nF	+/-10%	6.3V	0201
C1437	100nF	+/-10%	6.3V	0201
C1416	100nF	+/-10%	6.3V	0201
C1435	100nF	+/-10%	6.3V	0201
C1421	100nF	+/-10%	6.3V	0201
C1423	100nF	+/-10%	6.3V	0201
C1425	100nF	+/-10%	6.3V	0201
C1424	100nF	+/-10%	6.3V	0201
C1447	100nF	+/-10%	6.3V	0201

C1448	100nF	+/-10%	6.3V	0201
C1449	100nF	+/-10%	6.3V	0201
C1450	100nF	+/-10%	6.3V	0201
C1451	100nF	+/-10%	6.3V	0201
C1452	100nF	+/-10%	6.3V	0201
C1453	100nF	+/-10%	6.3V	0201
C1454	100nF	+/-10%	6.3V	0201
C1455	100nF	+/-10%	6.3V	0201

C1457	100nF	+/-10%	6.3V	0201
C1458	100nF	+/-10%	6.3V	0201
C1459	100nF	+/-10%	6.3V	0201
C1460	100nF	+/-10%	6.3V	0201
C1461	100nF	+/-10%	6.3V	0201
C1462	100nF	+/-10%	6.3V	0201
C1463	100nF	+/-10%	6.3V	0201
C1464	100nF	+/-10%	6.3V	0201
C1465	100nF	+/-10%	6.3V	0201
C1466	100nF	+/-10%	6.3V	0201

C1467	100nF	+/-10%	6.3V	0201
C1468	100nF	+/-10%	6.3V	0201
C1469	100nF	+/-10%	6.3V	0201
C1470	100nF	+/-10%	6.3V	0201
C1471	100nF	+/-10%	6.3V	0201

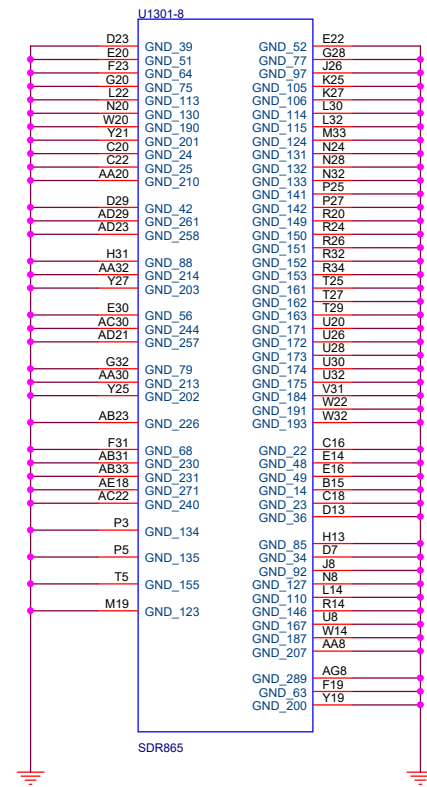
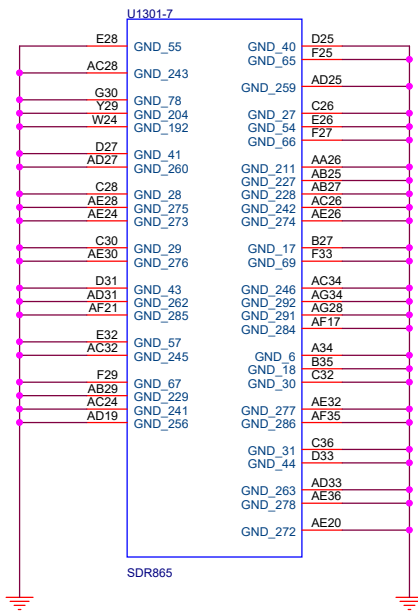
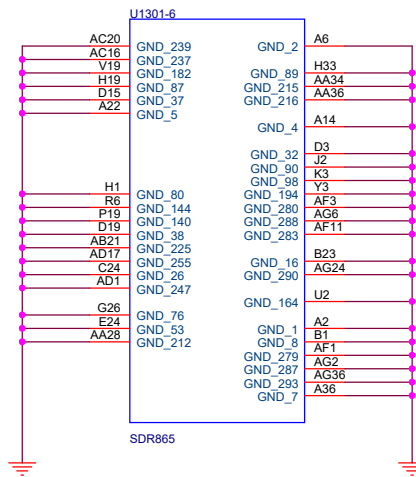
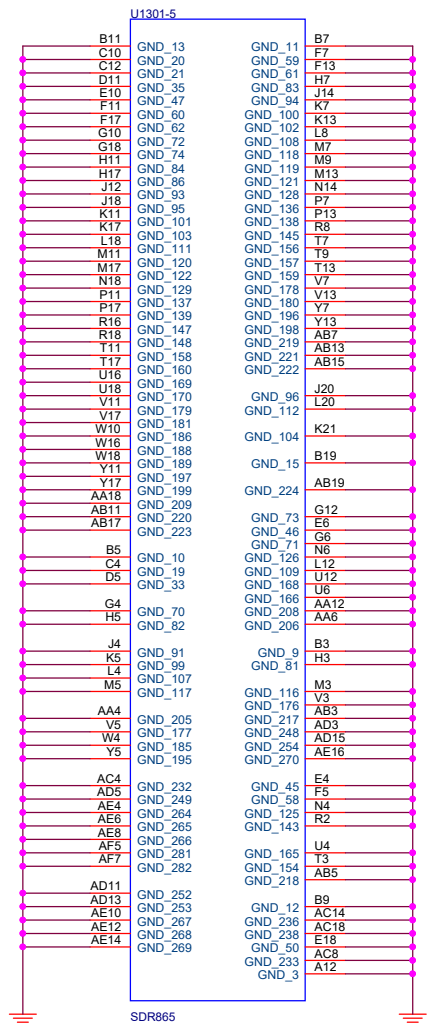

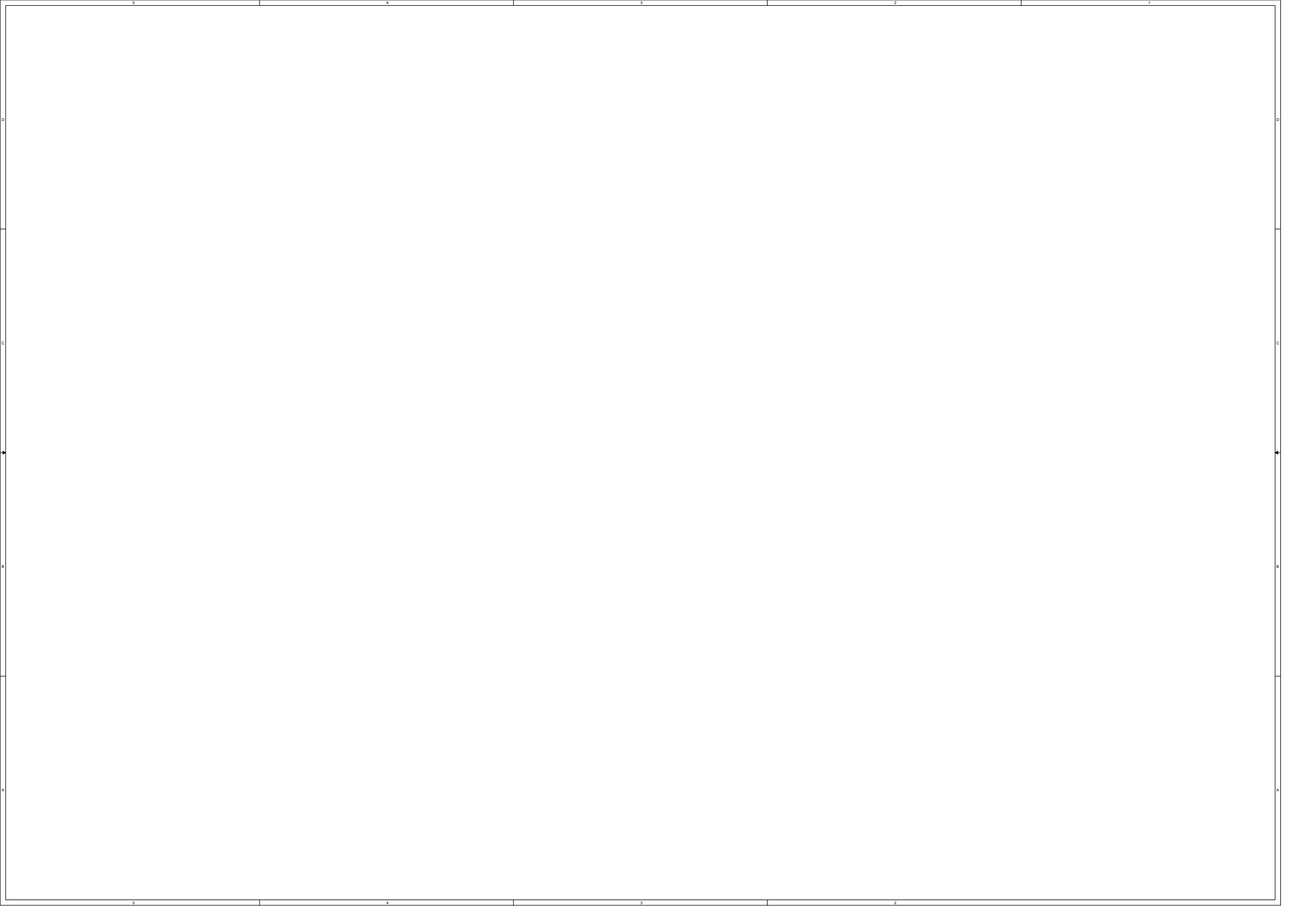

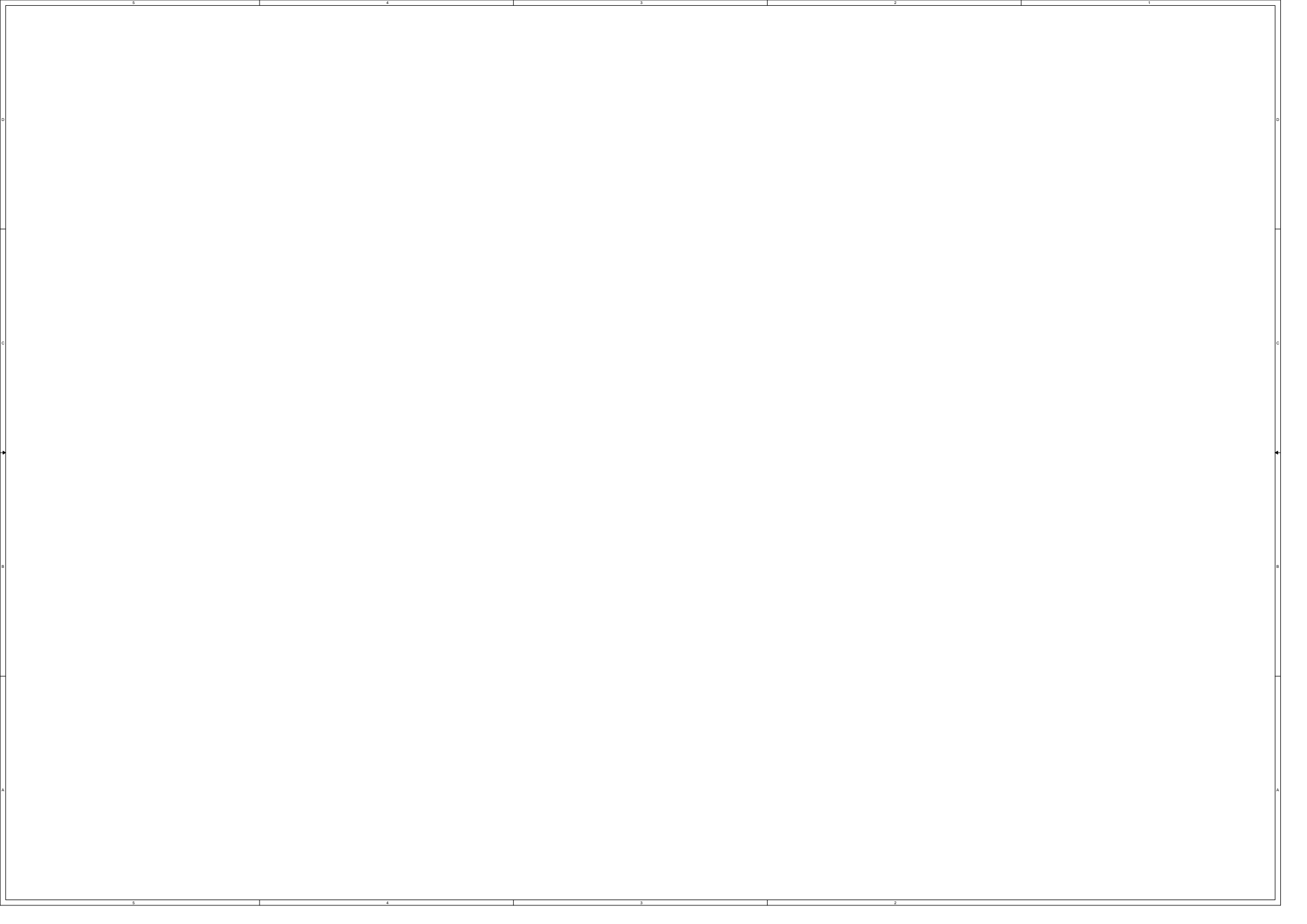

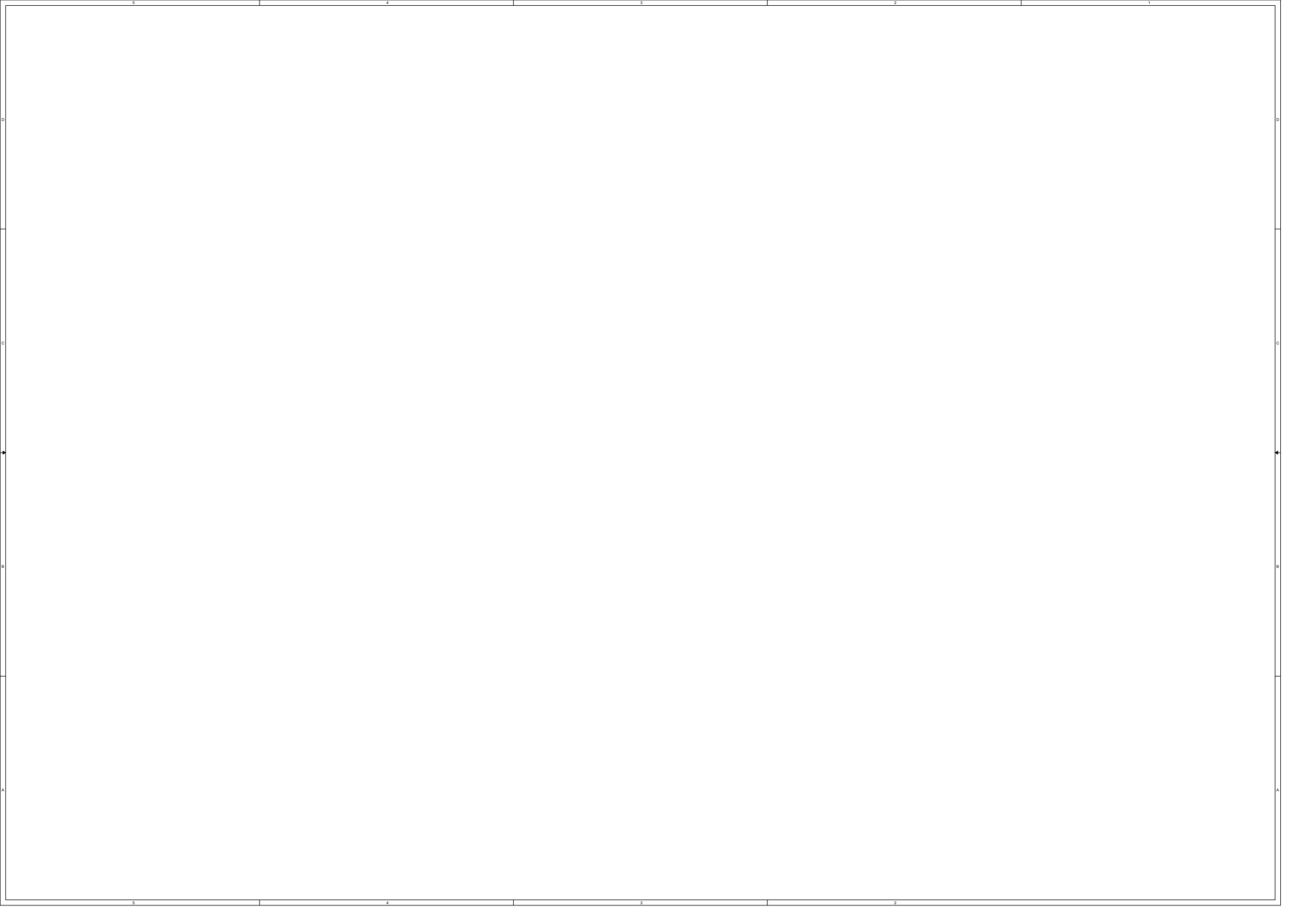

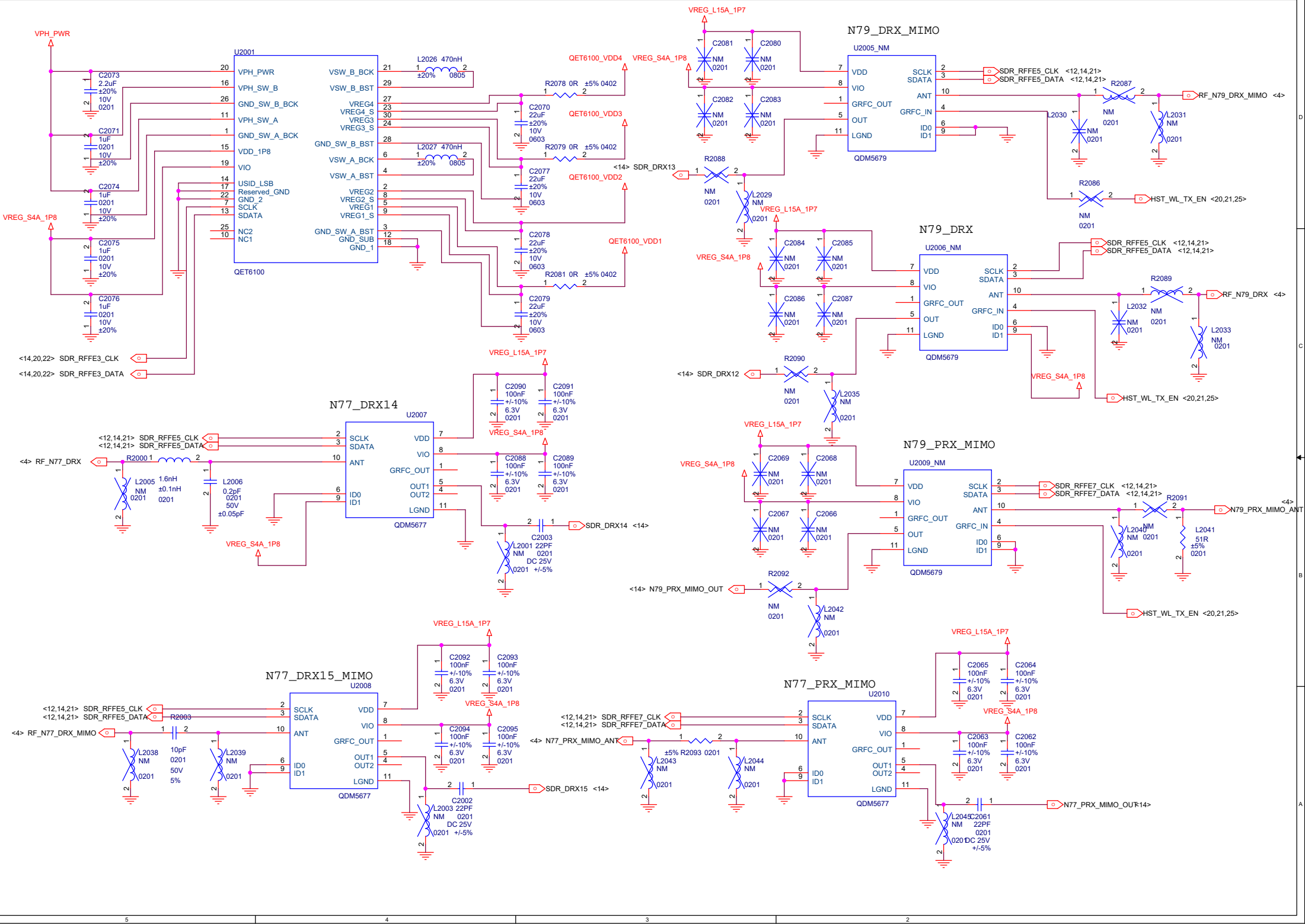

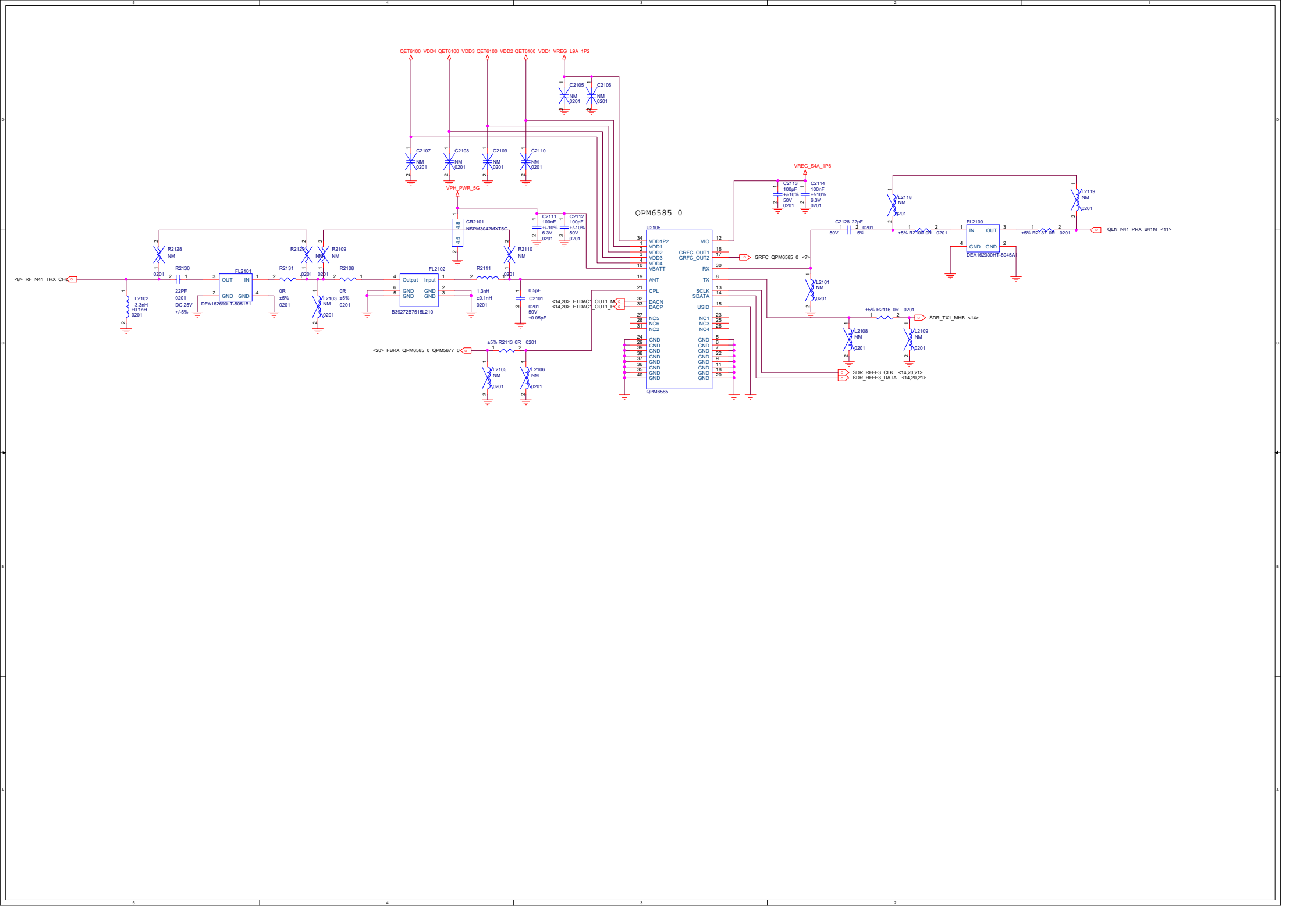

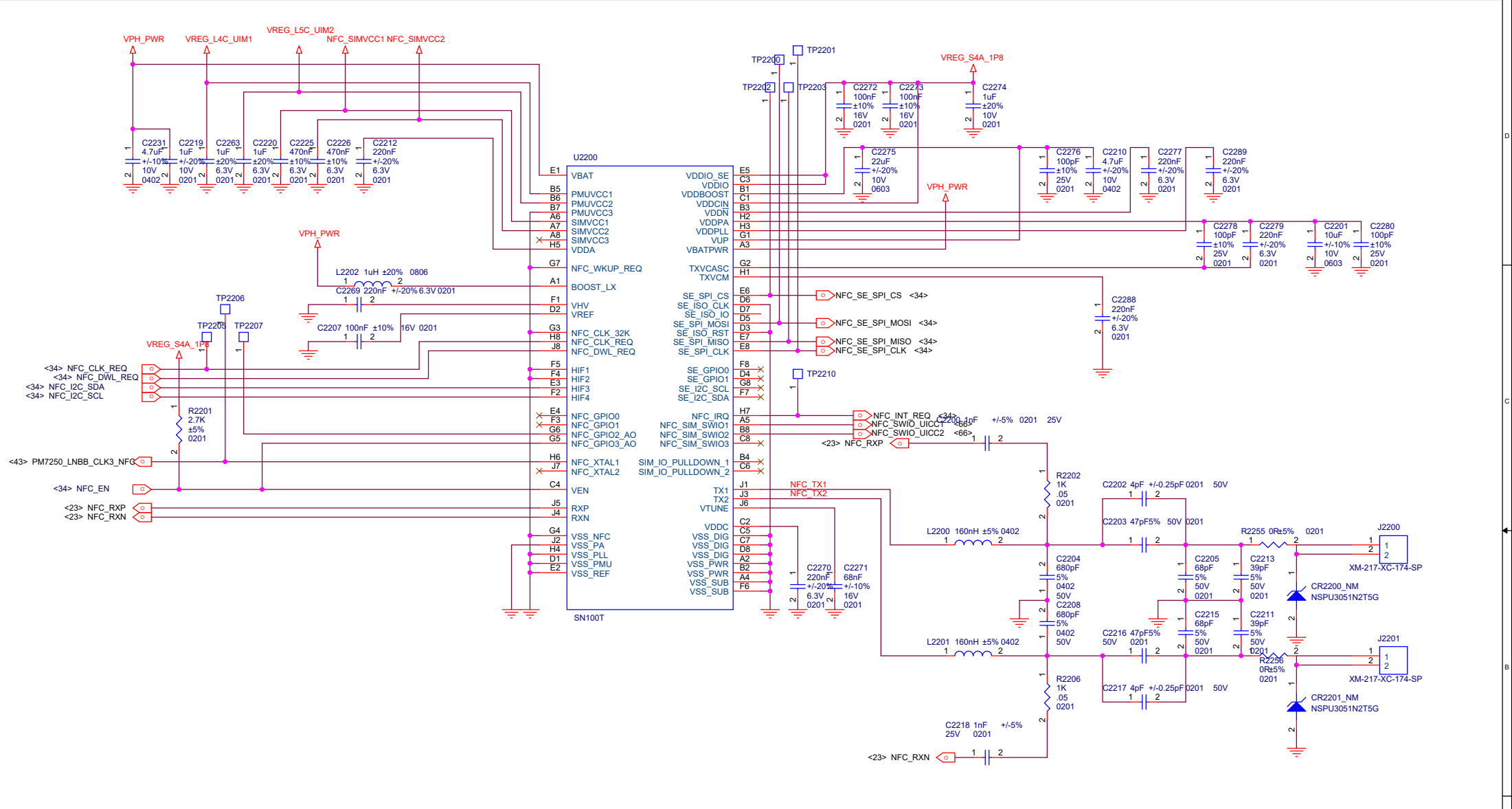

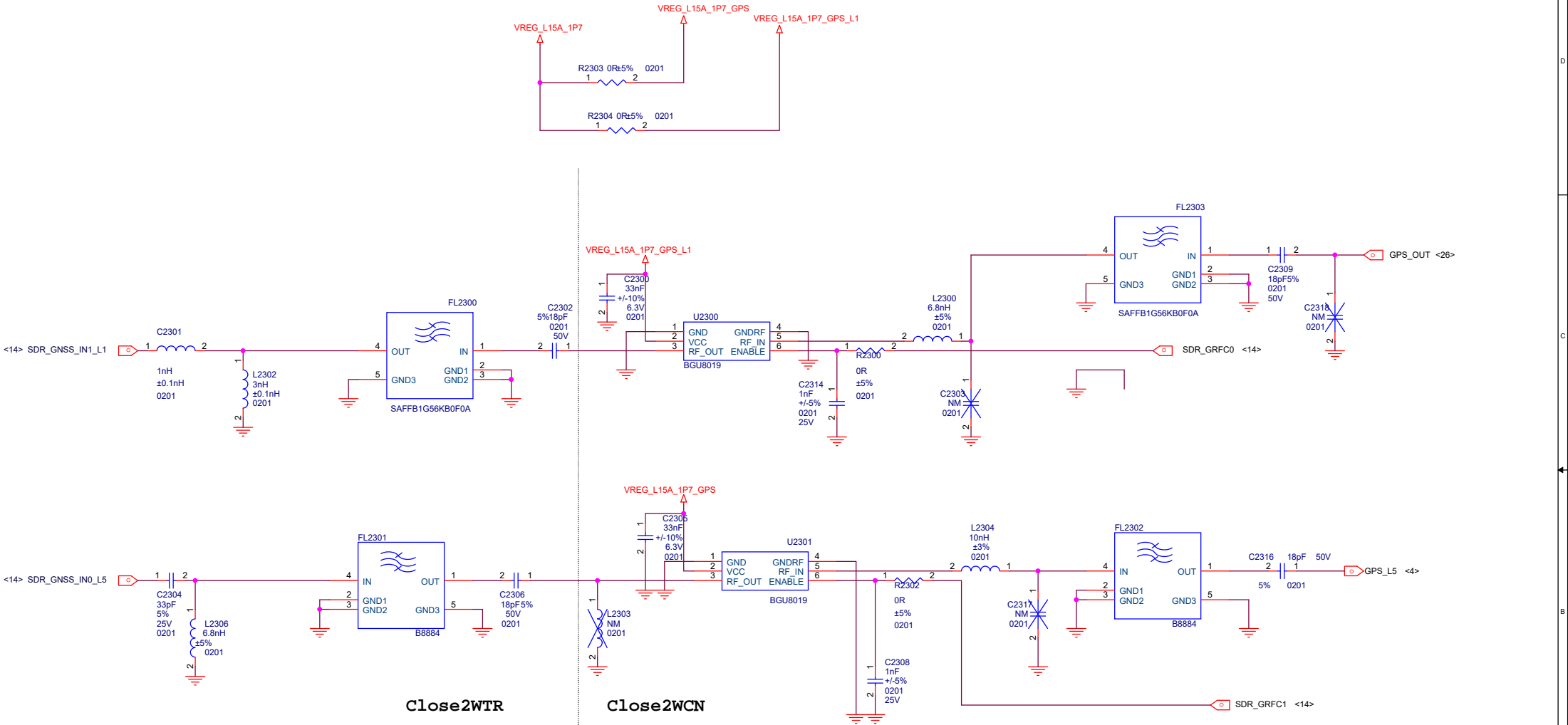

Close2WTR

Close2WCN

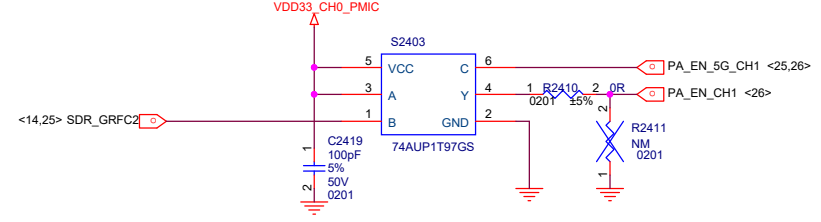
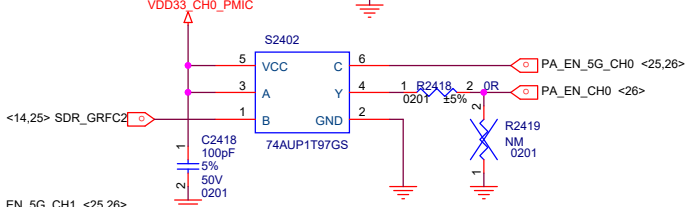
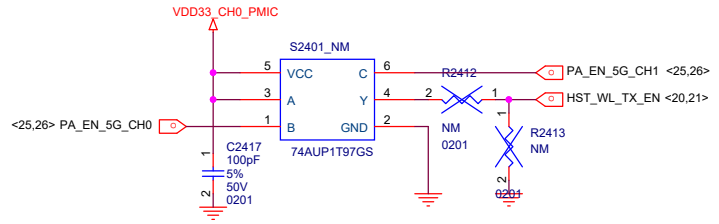
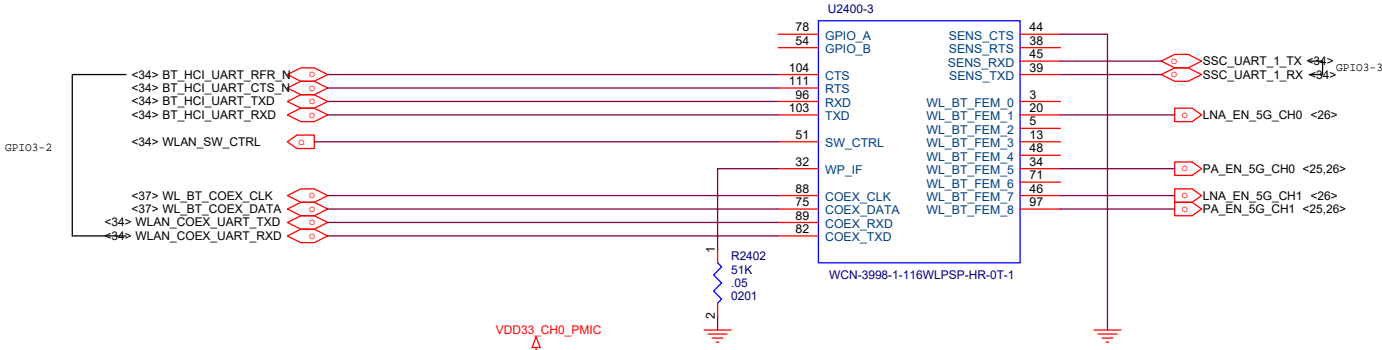
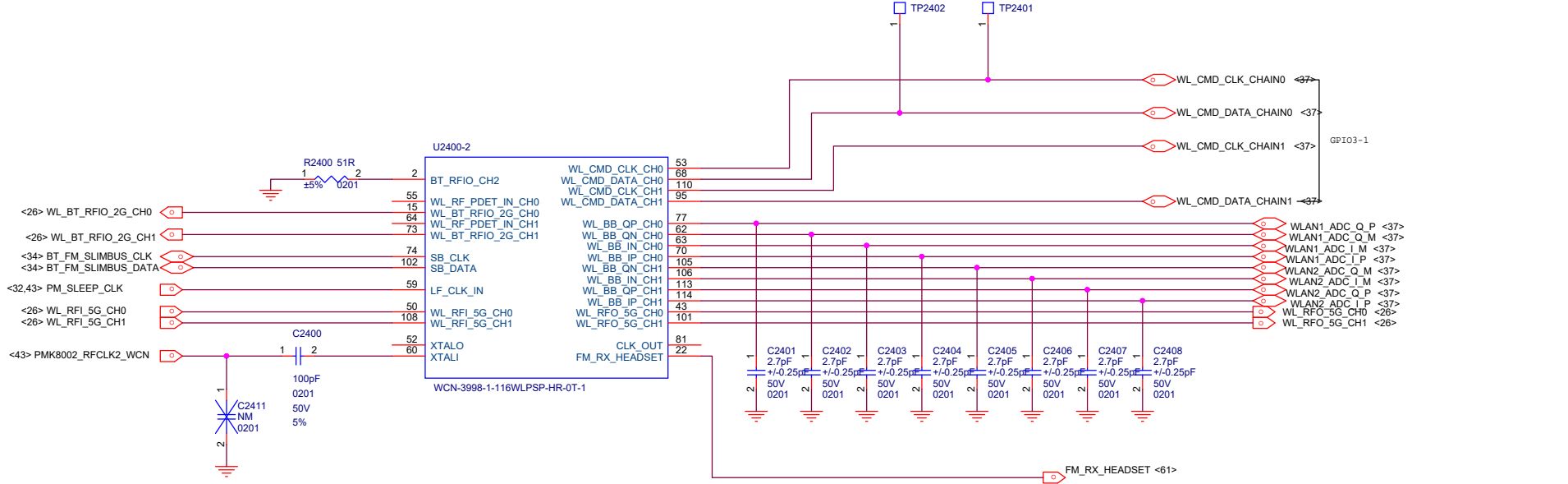

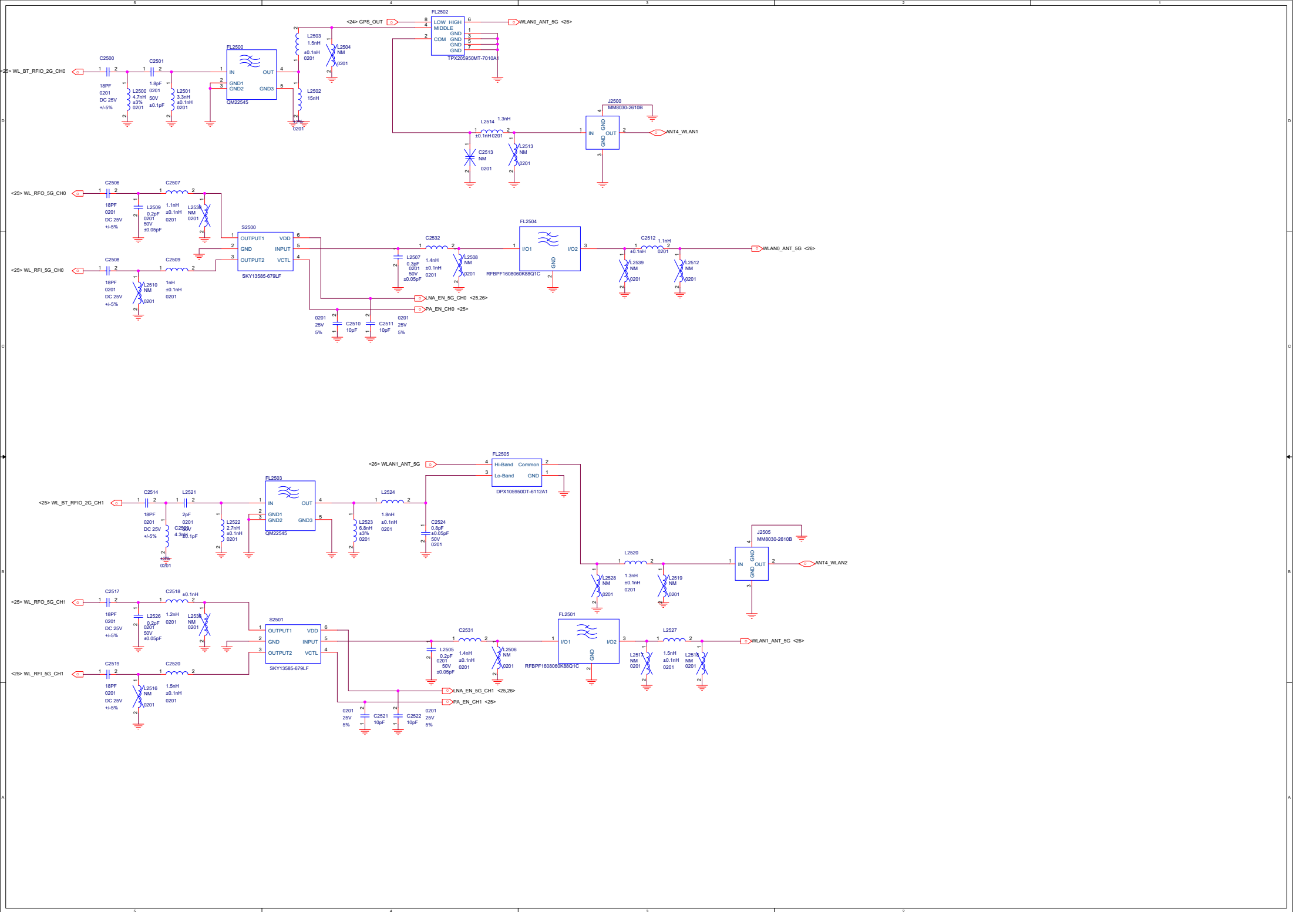

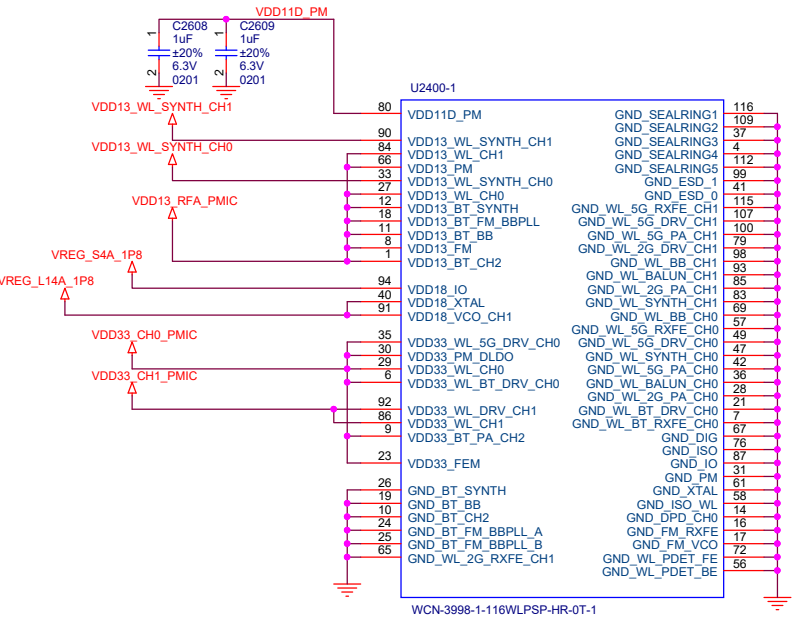
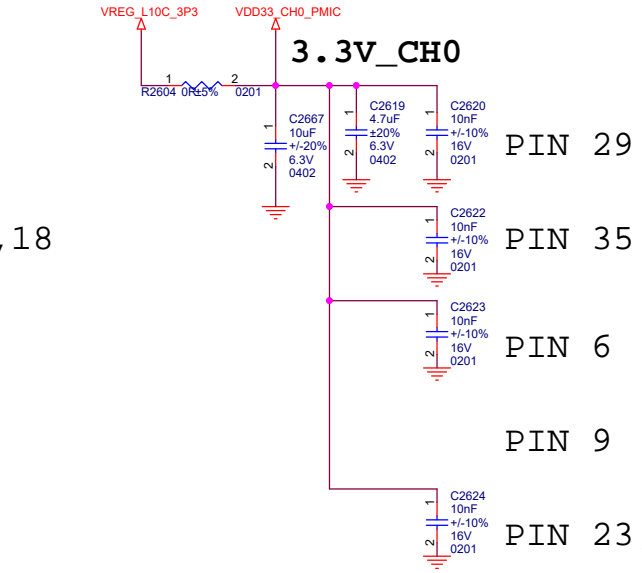
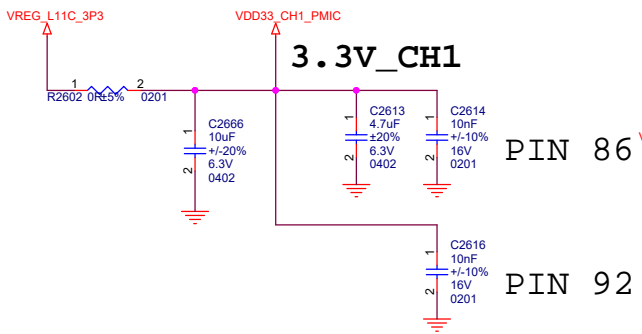
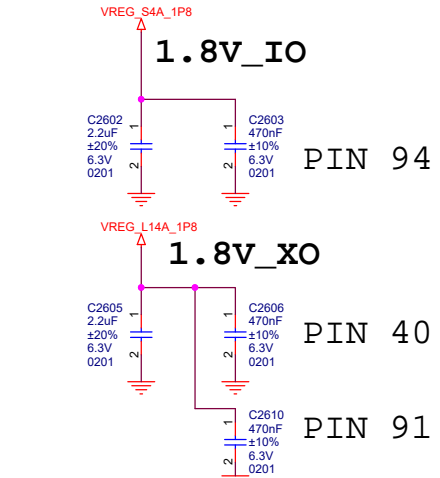
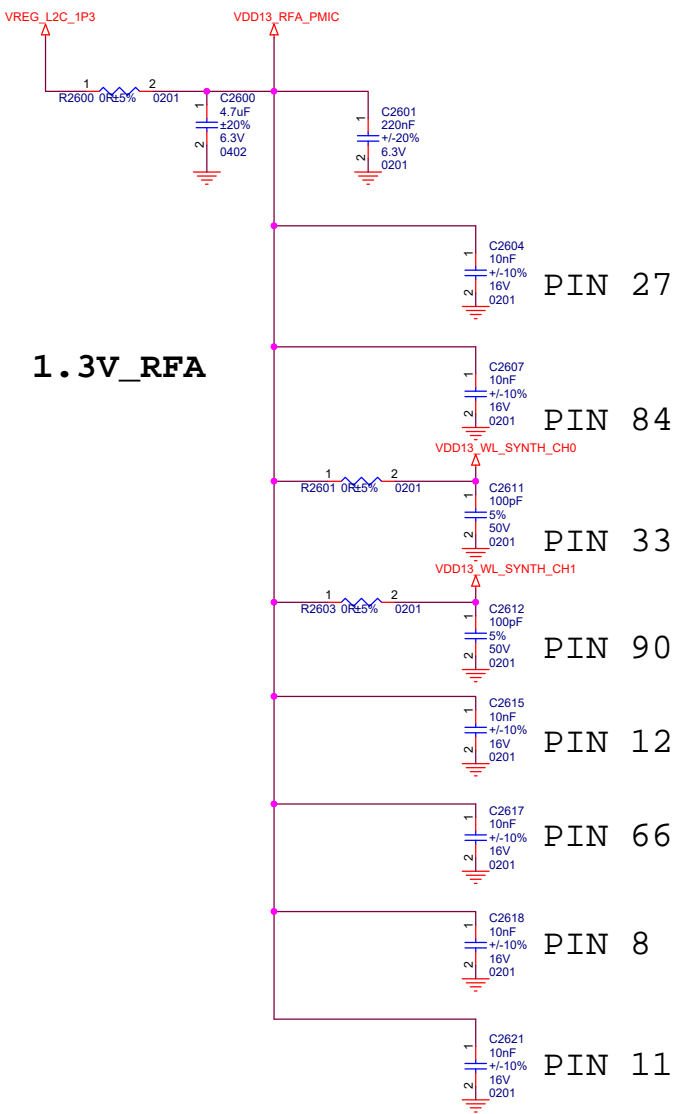

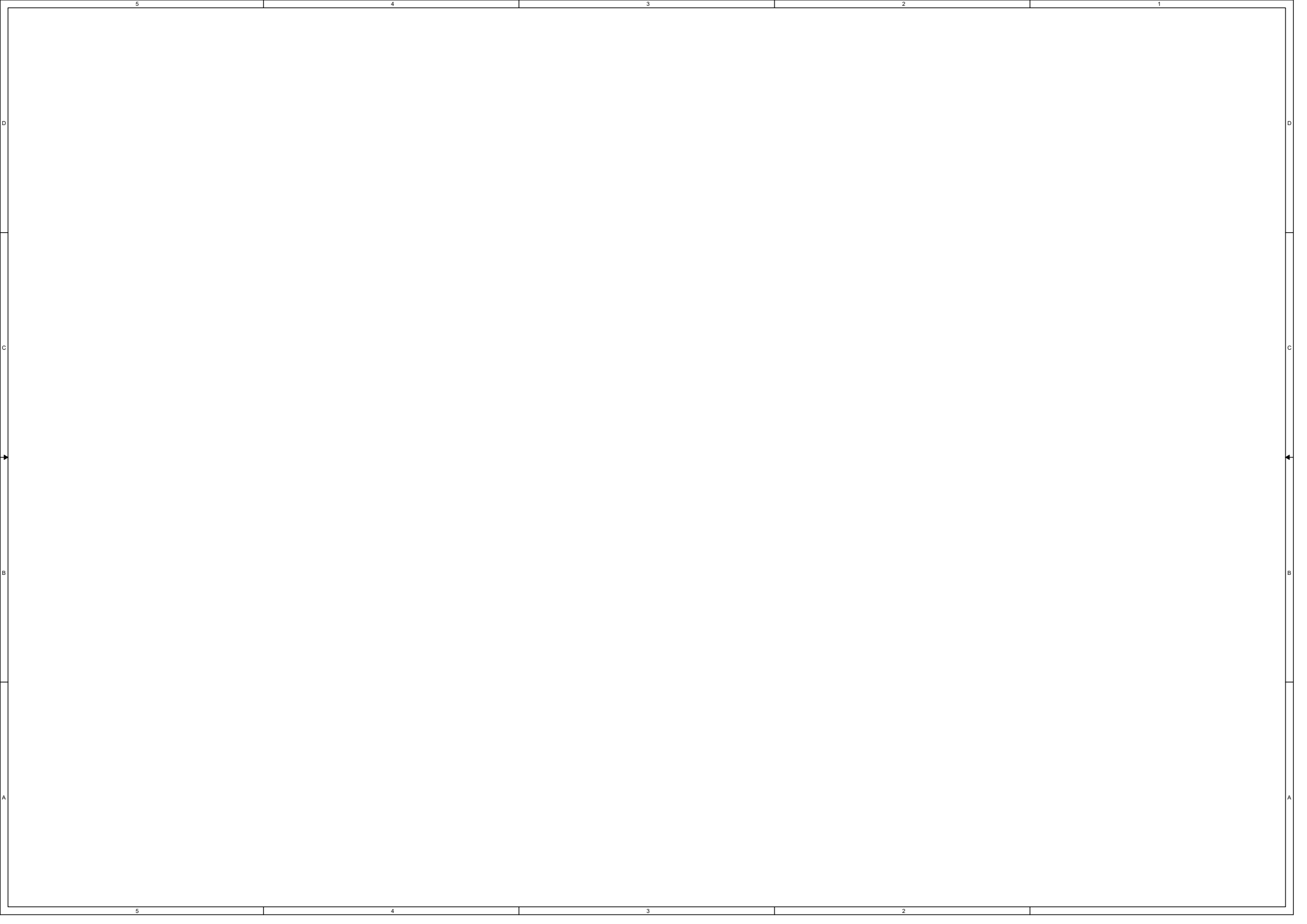

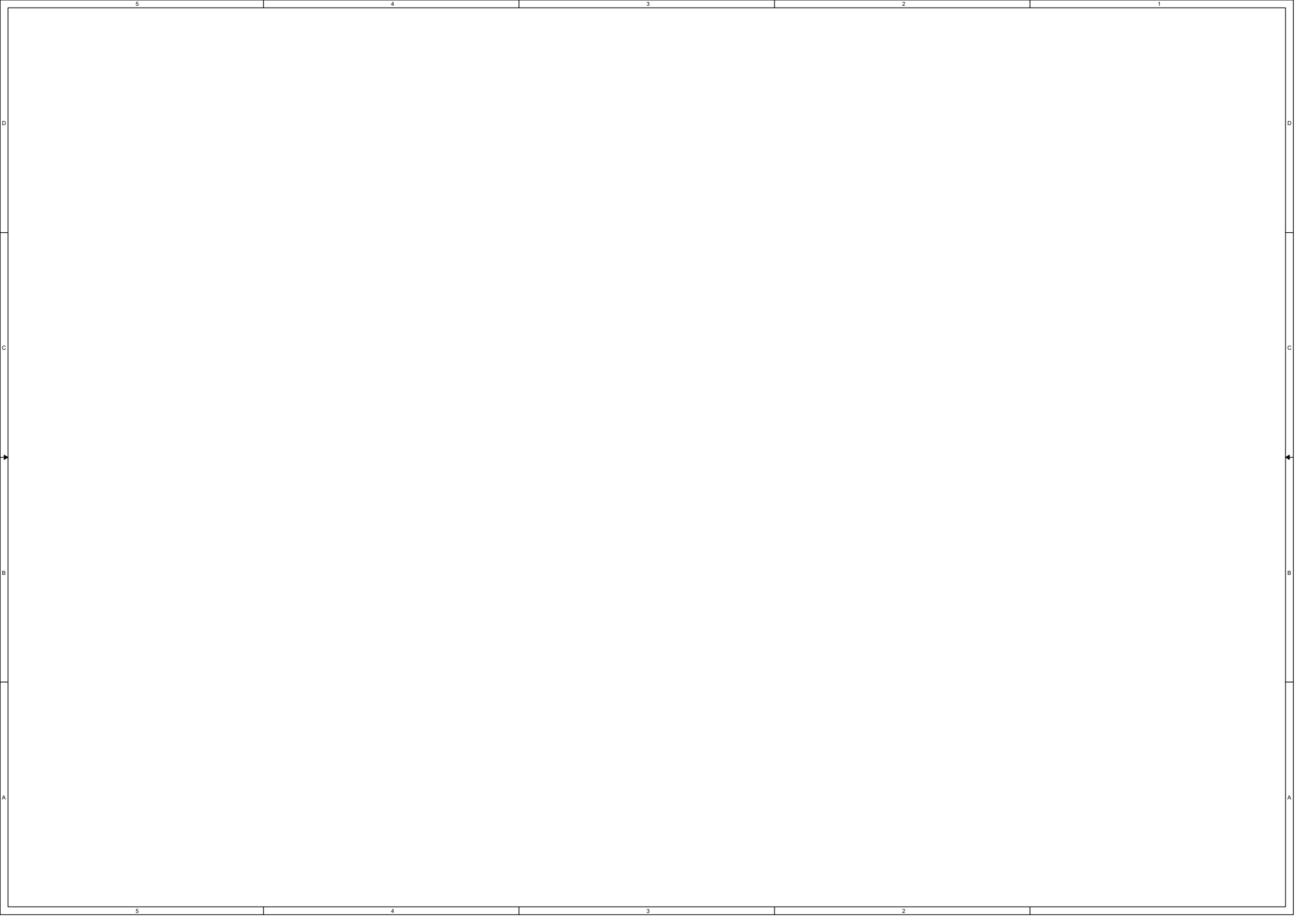

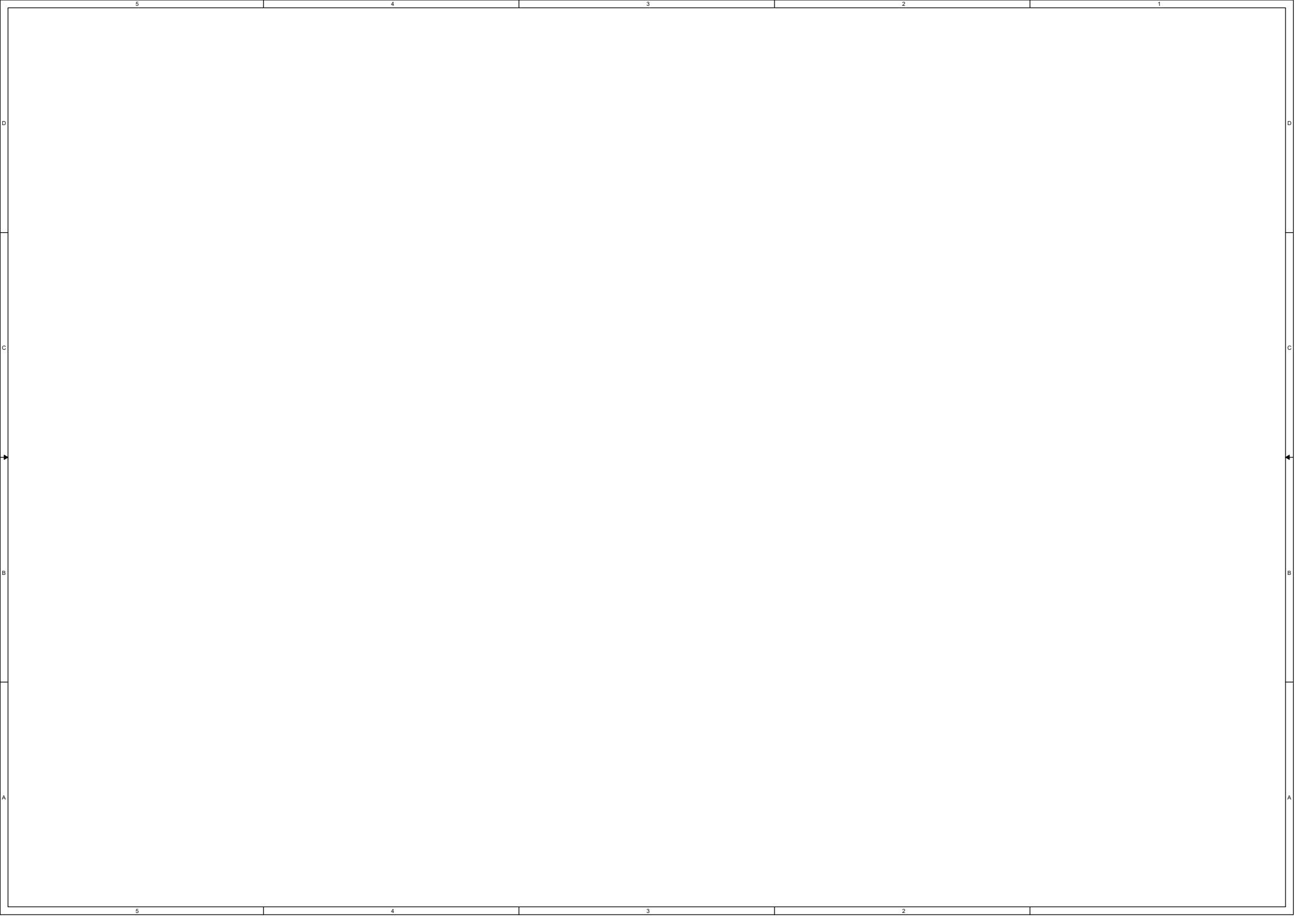

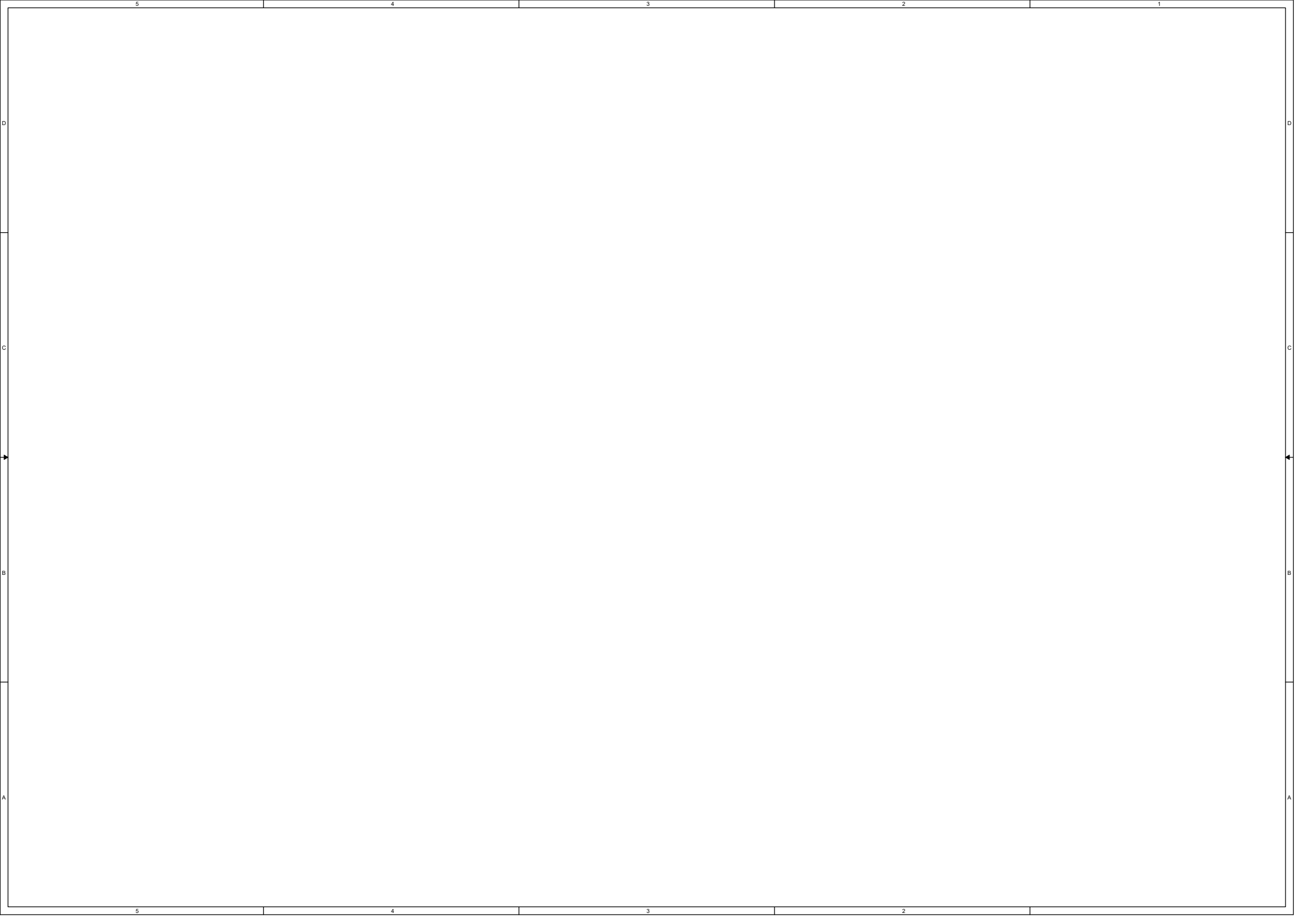

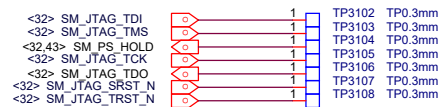
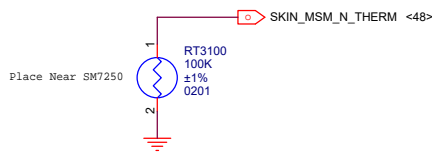
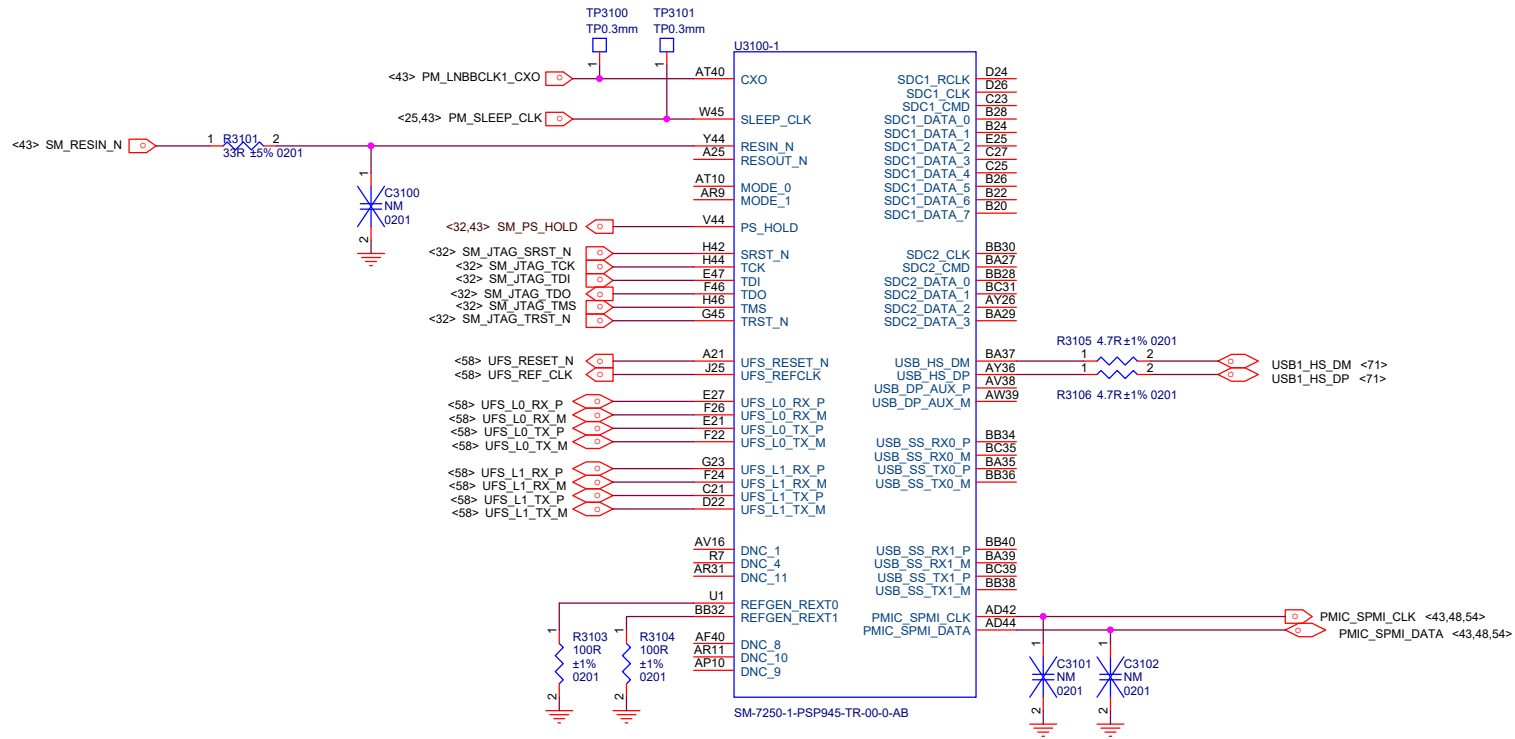

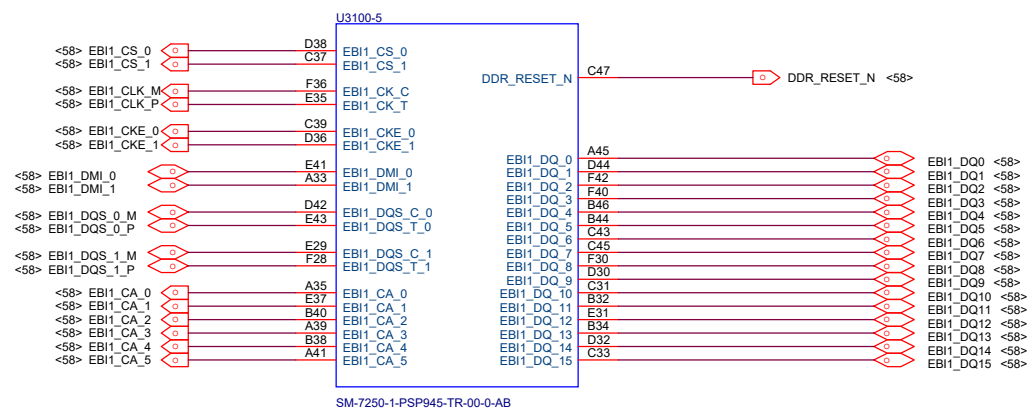
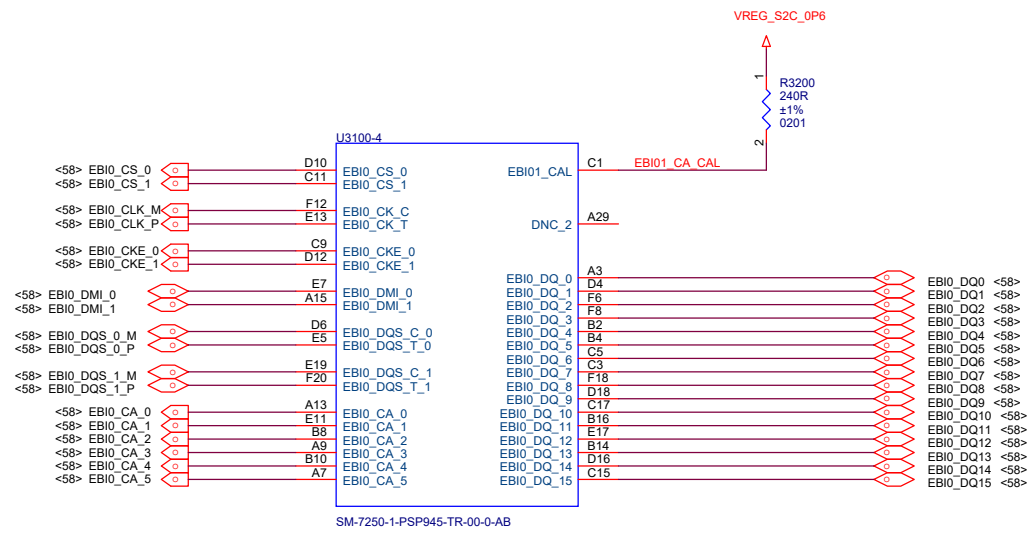

ULTRA CAMERA
8M
DEEP CAMERA
2M

MIPI_ULTRA_CLK_P
MIPI_ULTRA_CLK_M
MIPI_ULTRA_LANE0_P
MIPI_ULTRA_LANE0_M
MIPI_ULTRA_LANE1_P
MIPI_ULTRA_LANE1_M
MIPI_DEEP_LANE0_P
MIPI_DEEP_LANE0_M
MIPI_DEEP_CLK_P
MIPI_DEEP_CLK_M

WIDE CAMERA

<67> MIPI_W_trio0A
<67> MIPI_W_trio0B
<67> MIPI_W_trio0C
<67> MIPI_W_trio1A
<67> MIPI_W_trio1B
<67> MIPI_W_trio1C
<67> MIPI_W_trio2A
<67> MIPI_W_trio2B
<67> MIPI_W_trio2C

<65> MIPI_DSIO_CLK_P
<65> MIPI_DSIO_CLK_M
<65> MIPI_DSIO_LANE0_P
<65> MIPI_DSIO_LANE0_M
<65> MIPI_DSIO_LANE1_P
<65> MIPI_DSIO_LANE1_M
<65> MIPI_DSIO_LANE2_P
<65> MIPI_DSIO_LANE2_M
<65> MIPI_DSIO_LANE3_P
<65> MIPI_DSIO_LANE3_M

U3100-6

AC1 CS10_NC_CLK_P
AD2 CS10_A0_CLK_M
AD4 CS10_B0_LN0_P
AE3 CS10_C0_LN0_M
AF2 CS10_A1_LN1_P
AG1 CS10_B1_LN1_M
AG3 CS10_C1_LN2_P
AH2 CS10_A2_LN2_M
AH4 CS10_B2_LN3_P
AJ3 CS10_C2_LN3_M

AD6 CS11_NC_CLK_P
AE7 CS11_A0_CLK_M
AE5 CS11_B0_LN0_P
AF4 CS11_C0_LN0_M
AG5 CS11_A1_LN1_P
AG7 CS11_B1_LN1_M
AH6 CS11_C1_LN2_P
AH8 CS11_A2_LN2_M
AJ7 CS11_B2_LN3_P
AJ7 CS11_C2_LN3_M

R45 DS10_B1_CLK_P
P44 DS10_C1_CLK_M
N47 DS10_A0_LN0_P
M46 DS10_B0_LN0_M
P46 DS10_C0_LN1_P
N45 DS10_A1_LN1_M
U45 DS10_A2_LN2_P
T46 DS10_B2_LN2_M
V46 DS10_C2_LN3_P
U47 DS10_NC_LN3_M

SM-7250-1-PSP945-TR-00-0-AB

U7 CS12_NC_CLK_P
V8 CS12_A0_CLK_M
W7 CS12_B0_LN0_P
Y8 CS12_C0_LN0_M
Y6 CS12_A1_LN1_P
AA7 CS12_B1_LN1_M
AA5 CS12_C1_LN2_P
AB6 CS12_A2_LN2_M
AB4 CS12_B2_LN3_P
AC5 CS12_C2_LN3_M

AC3 CS13_NC_CLK_P
AB2 CS13_A0_CLK_M
AA3 CS13_B0_LN0_P
Y4 CS13_C0_LN0_M
V2 CS13_A1_LN1_P
W3 CS13_B1_LN1_M
W1 CS13_C1_LN2_P
V2 CS13_A2_LN2_M
U3 CS13_B2_LN3_P
T2 CS13_C2_LN3_M

P42 DS11_B1_CLK_P
N41 DS11_C1_CLK_M
T42 DS11_A0_LN0_P
R41 DS11_B0_LN0_M
T44 DS11_C0_LN1_P
R43 DS11_A1_LN1_M
N43 DS11_A2_LN2_P
M44 DS11_B2_LN2_M
M42 DS11_C2_LN3_P
L43 DS11_NC_LN3_M

MIPI_F1_CLK_P <68>
MIPI_F1_CLK_M <68>
MIPI_F1_LANE0_P <68>
MIPI_F1_LANE0_M <68>
MIPI_F1_LANE1_P <68>
MIPI_F1_LANE1_M <68>
MIPI_F1_LANE2_P <68>
MIPI_F1_LANE2_M <68>
MIPI_F1_LANE3_P <68>
MIPI_F1_LANE3_M <68>

FRONT CAMERA

MICRO CAMERA

5M

FRONT2 CAMERA

2M

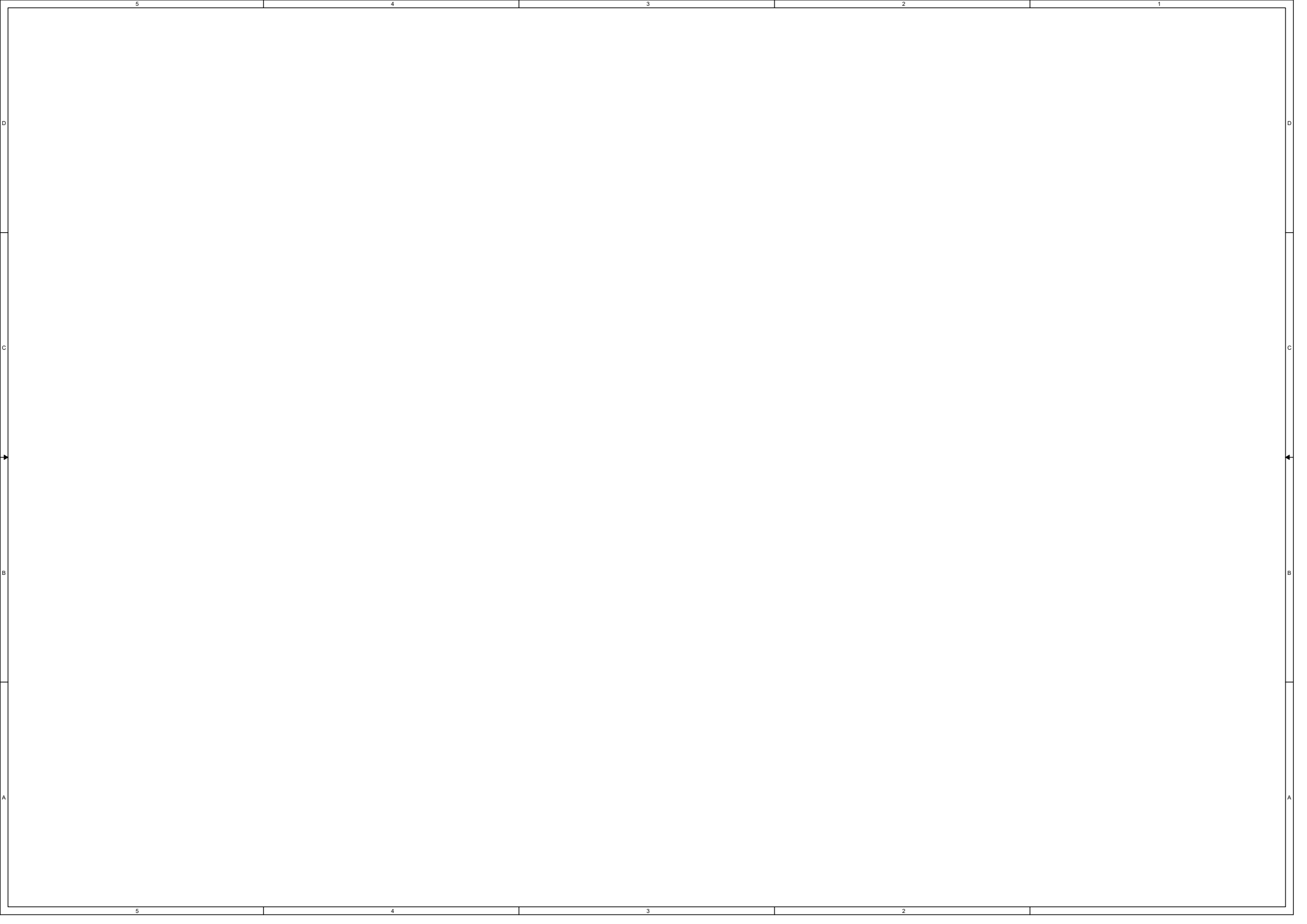

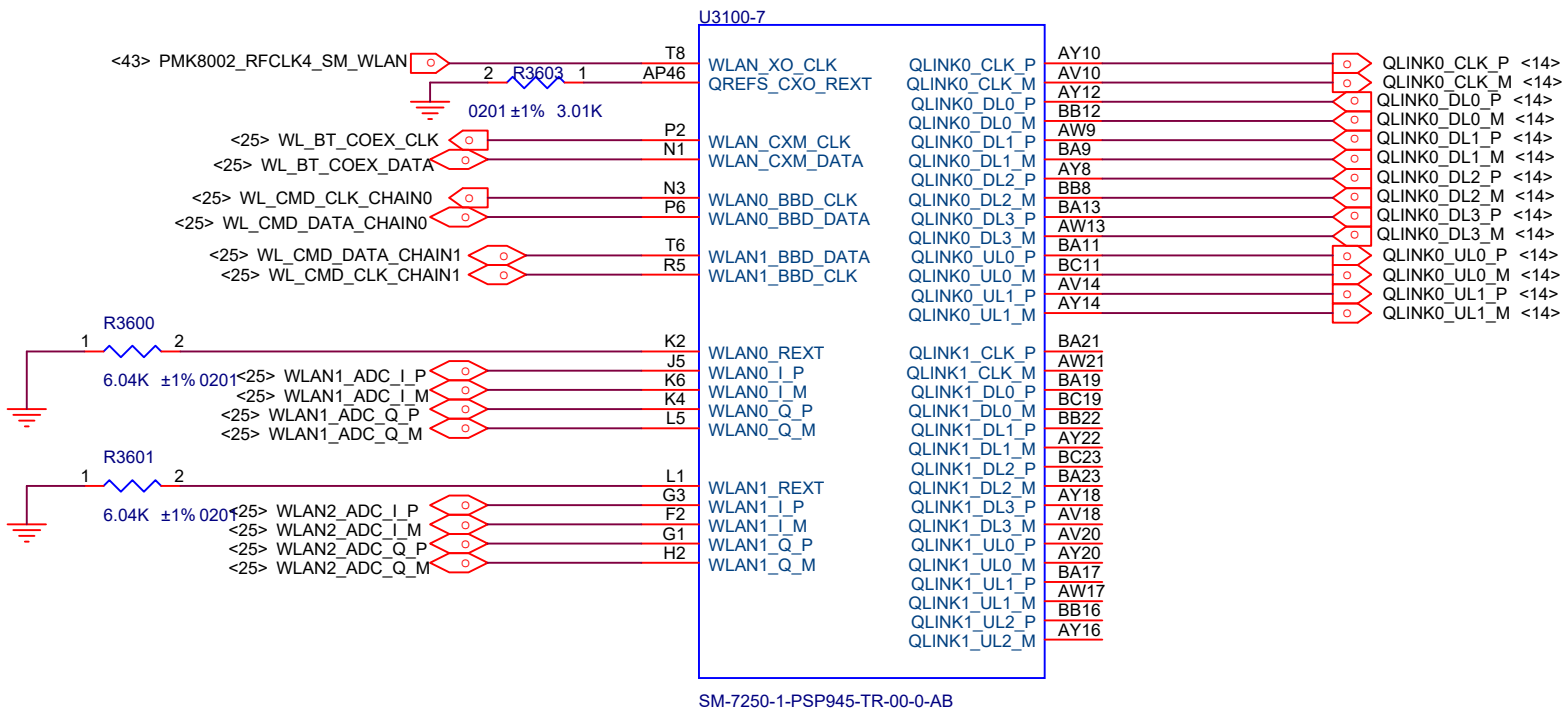

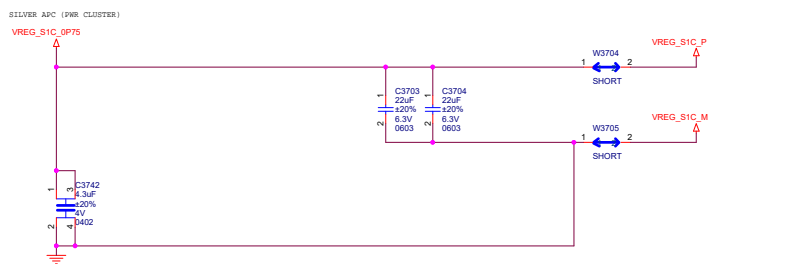
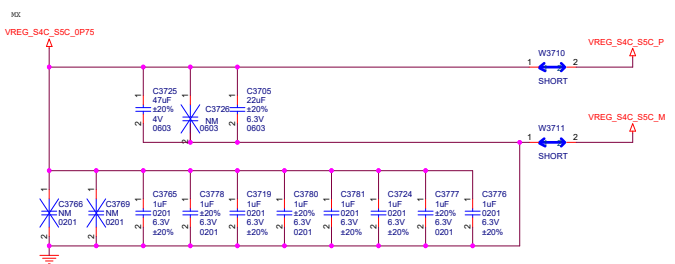
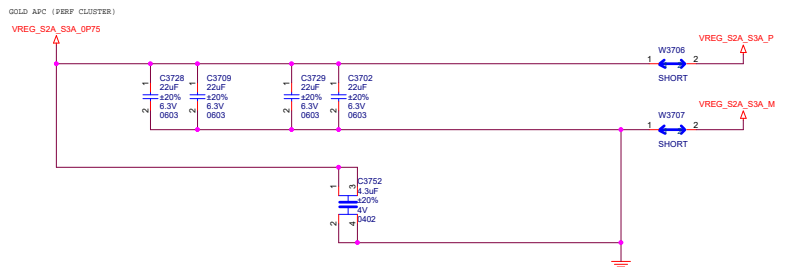
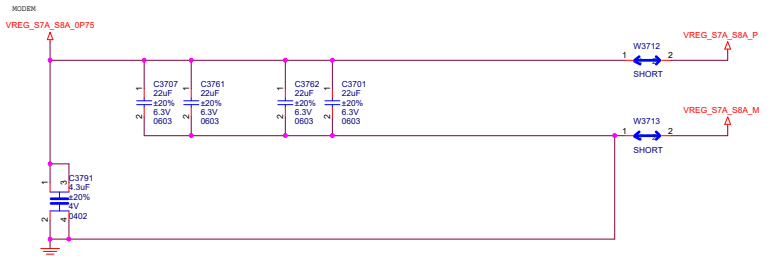
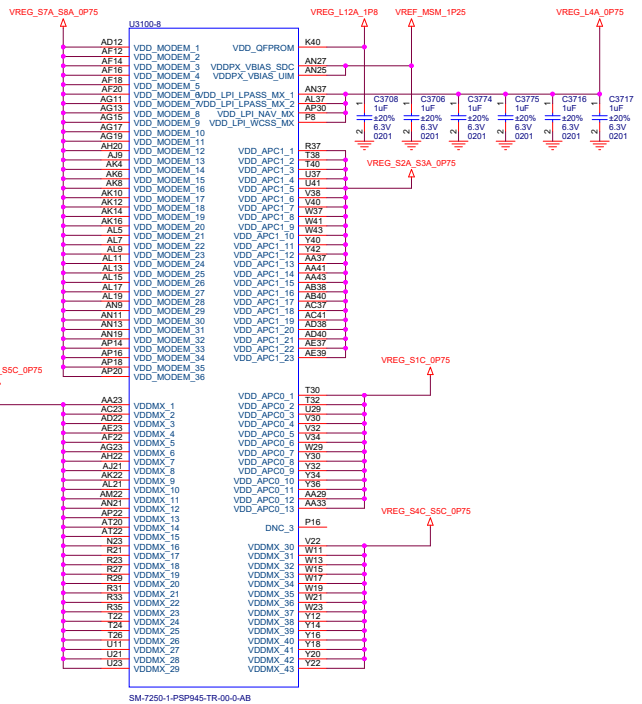



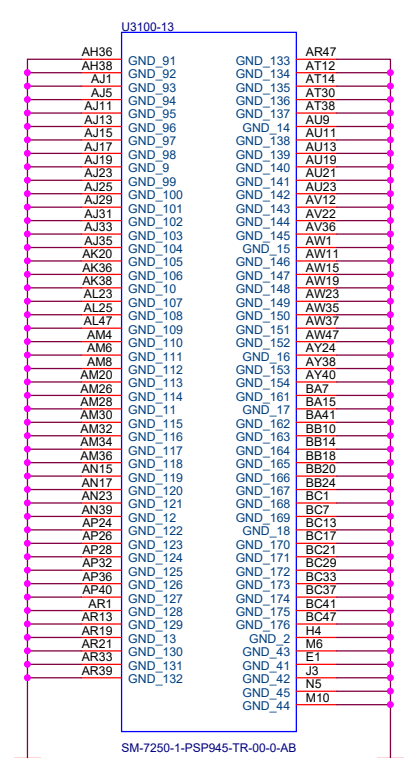
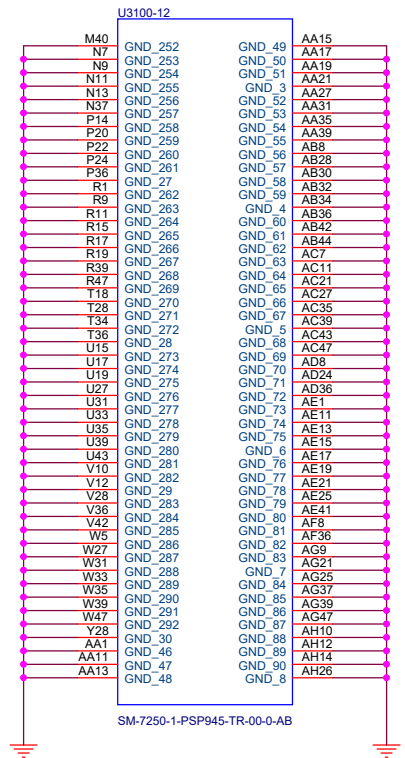
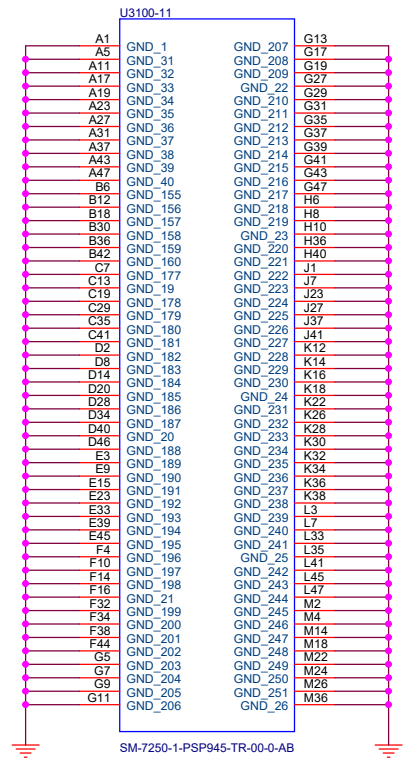

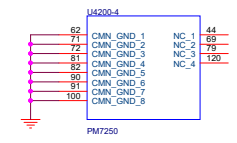
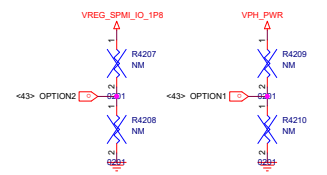
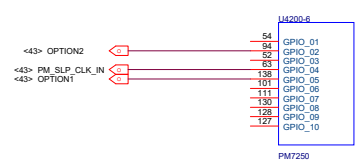
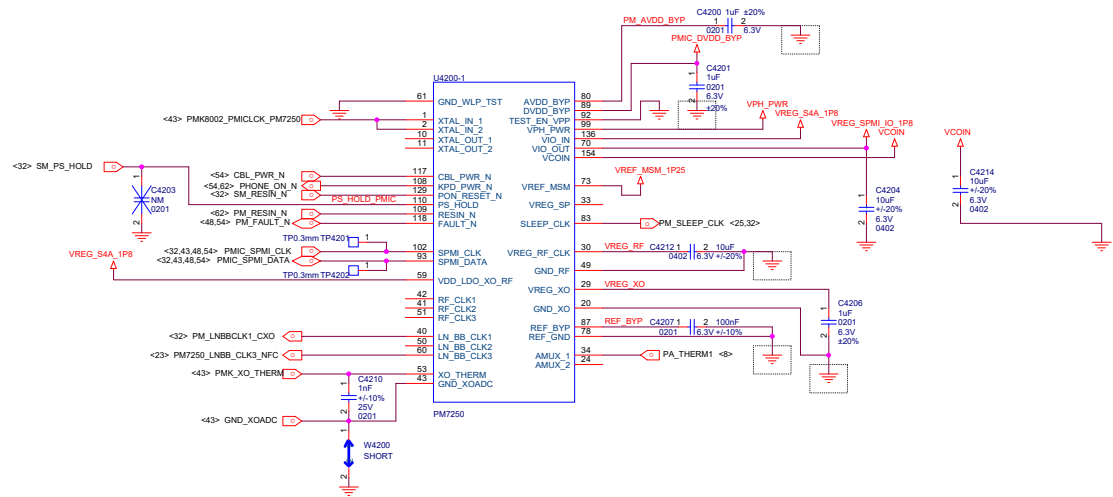

PMK8002_CLOCKS

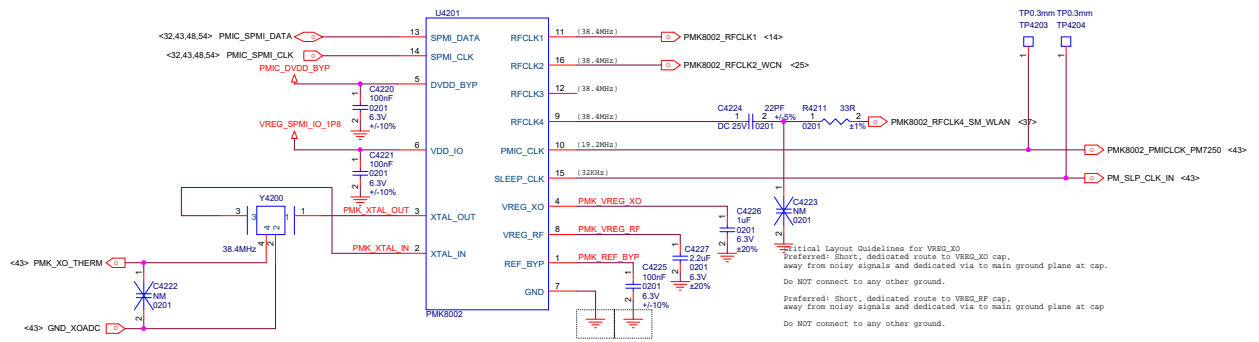

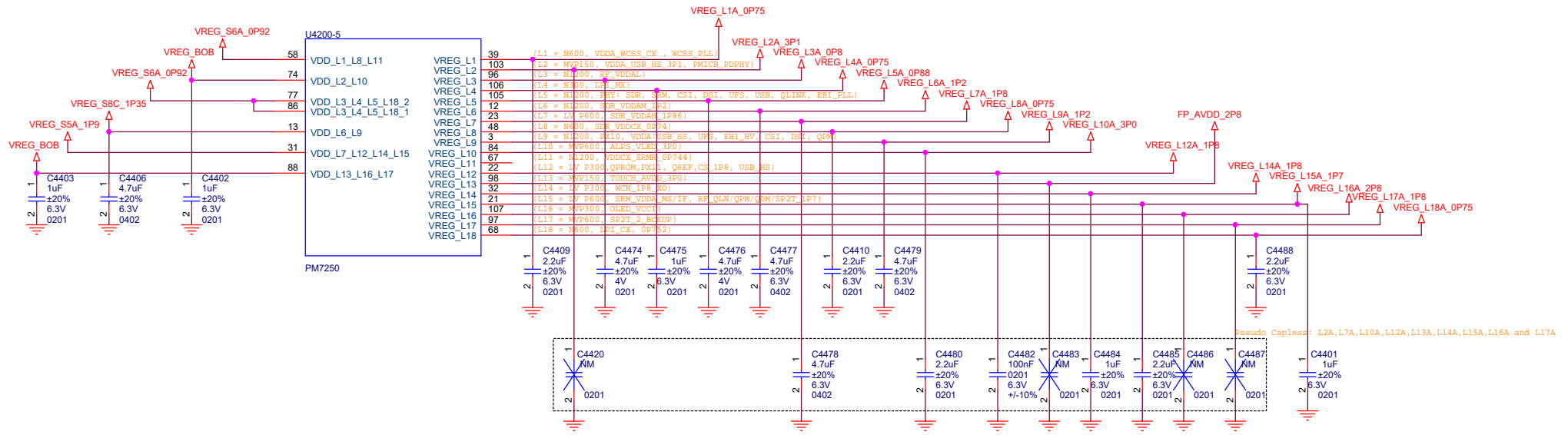

NOTE: PMIC internal regulators used VREG_L12A : BCLK_DRV

NOTE: P-type LDOs are pseudo-capless, capacitors can be placed near load. Regulators powering PMIC internal circuits need capacitors near PMIC. N-type LDOs with >300mA rating need local capacitors near PMIC.

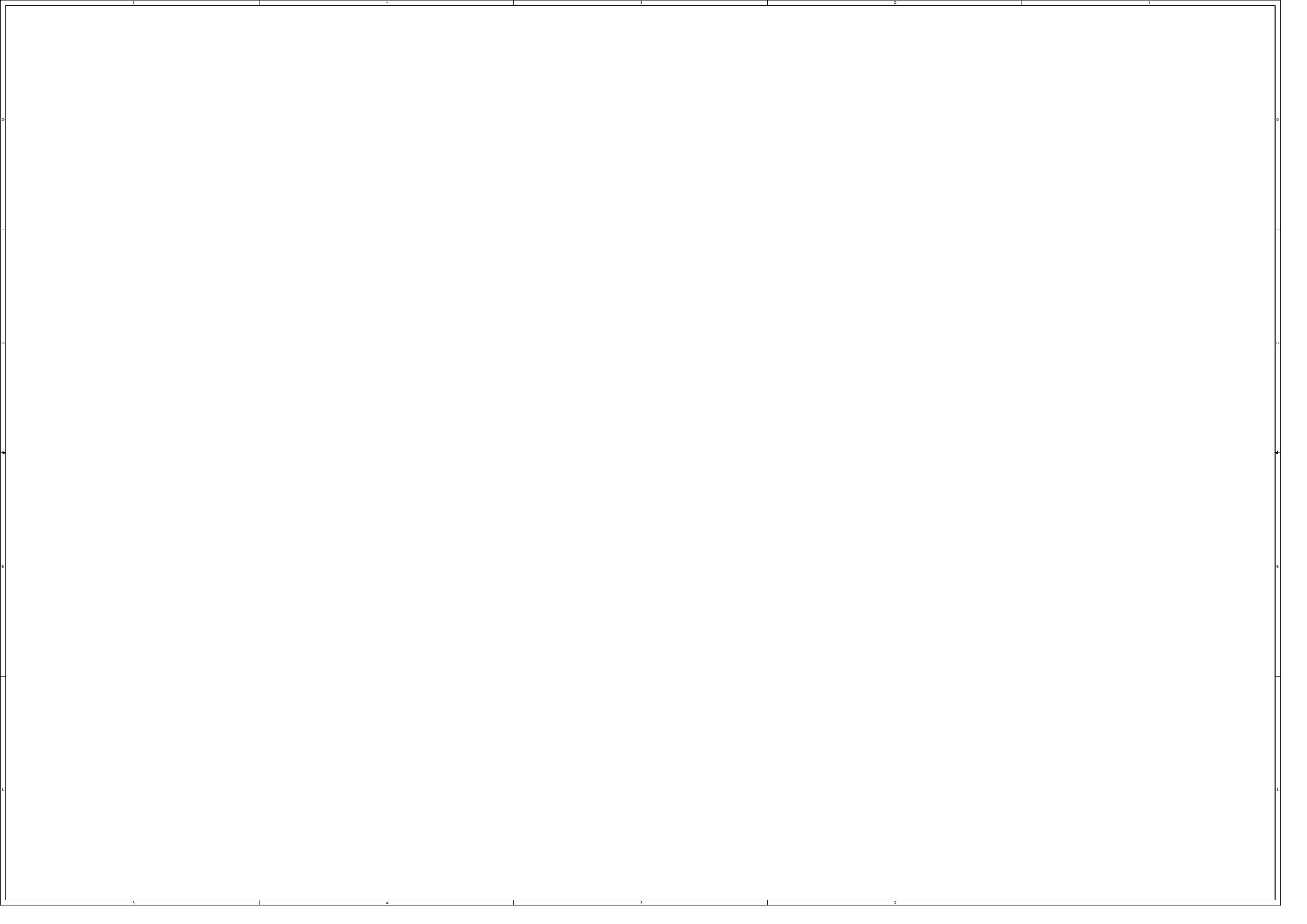

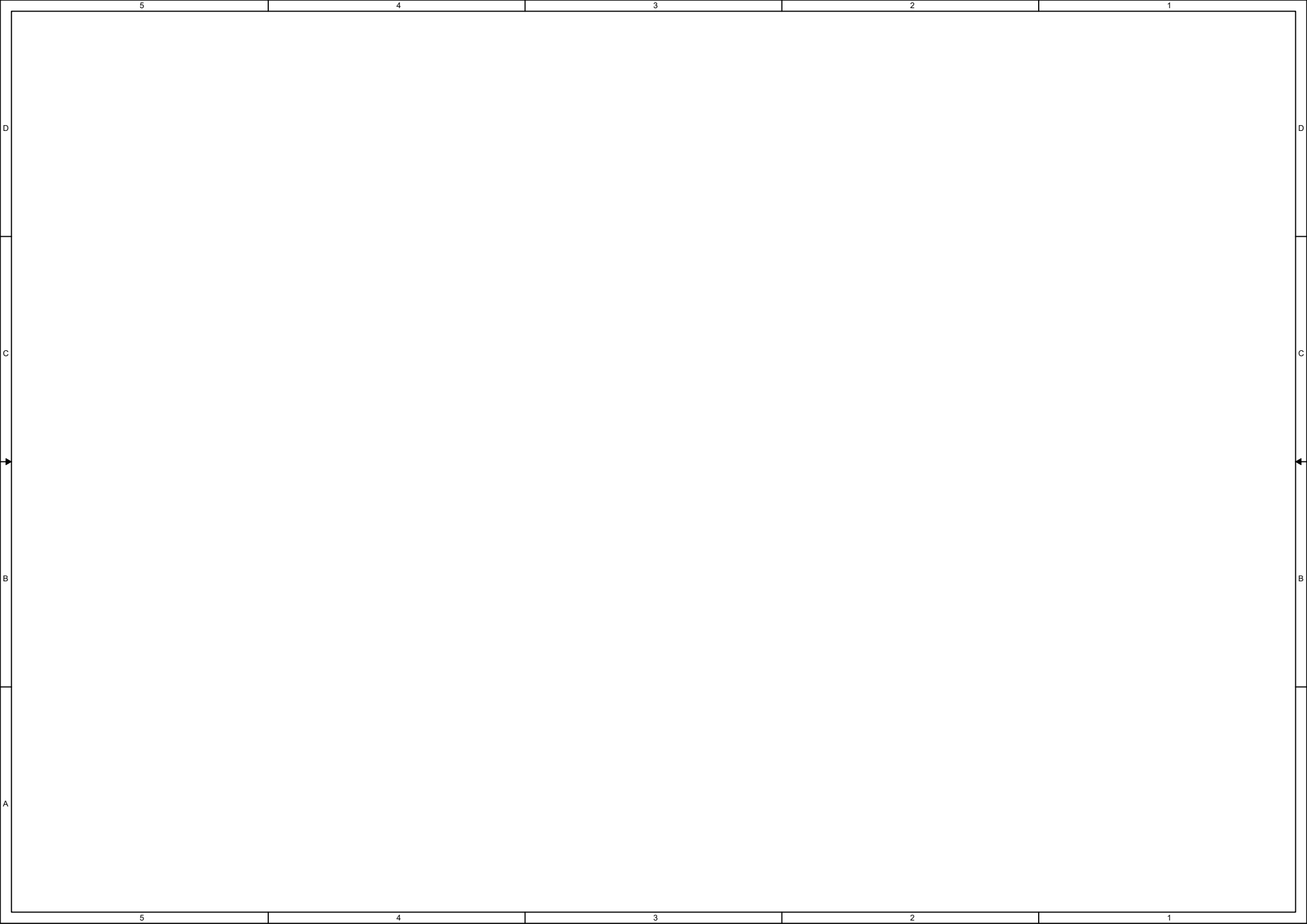

PM7150A_CONTROL/GPIO

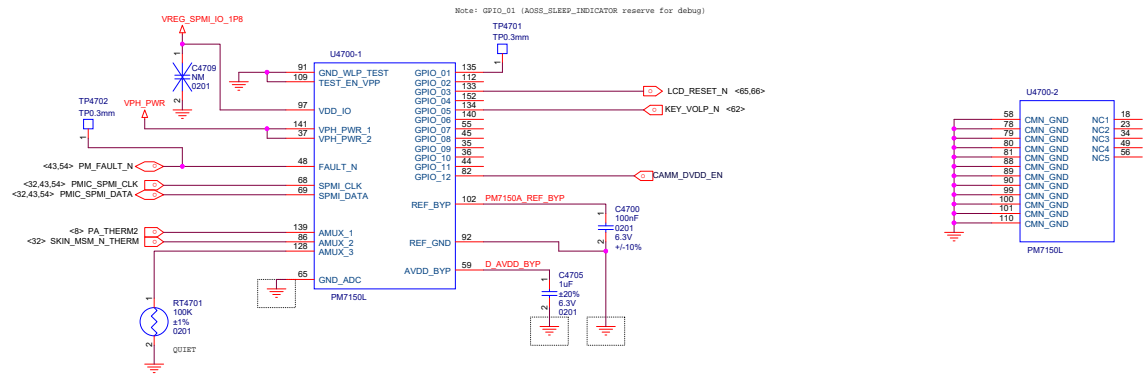

PM7150A_BOB/FLASH

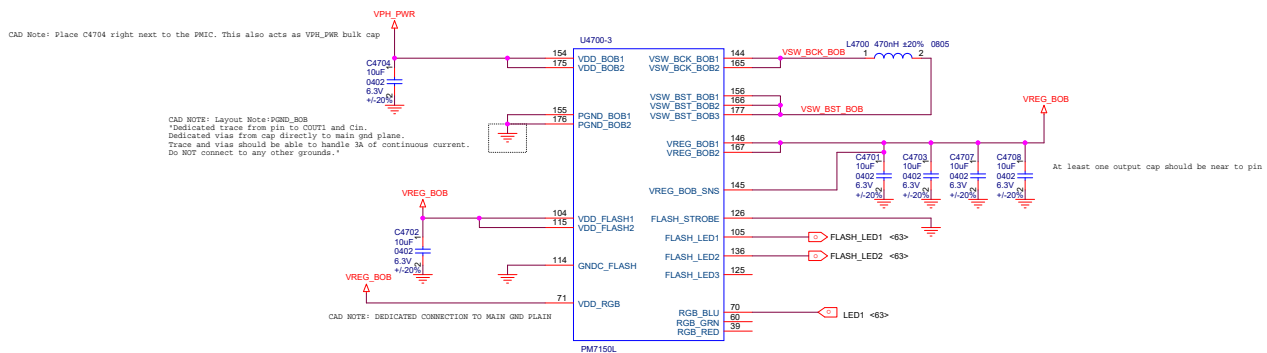

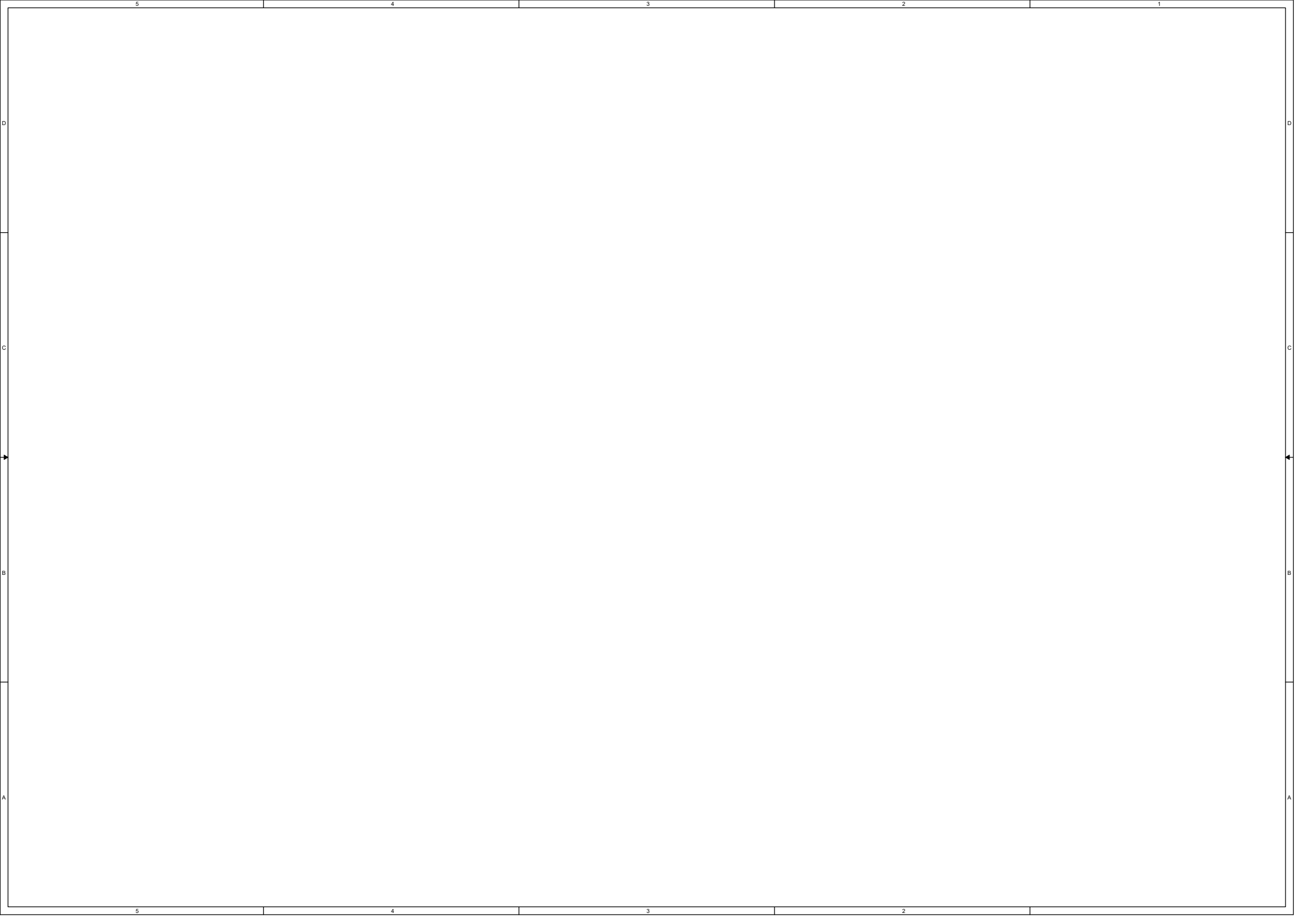

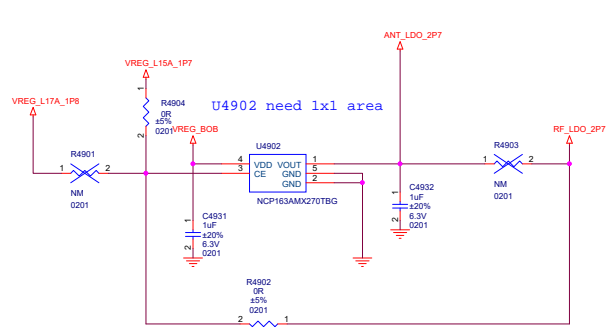
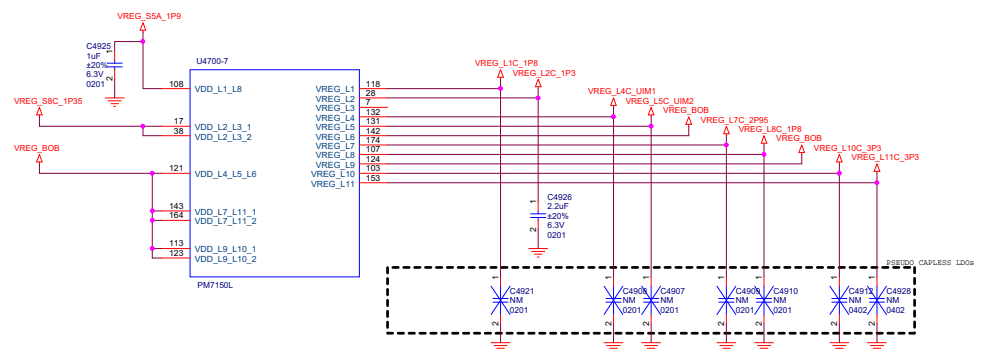
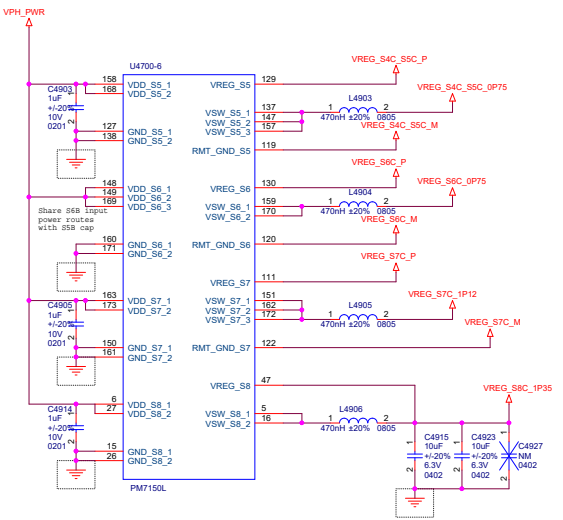
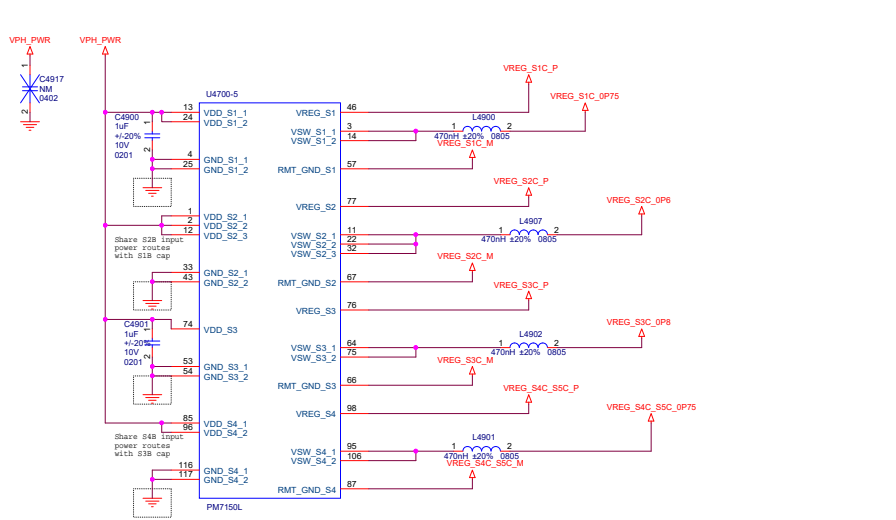

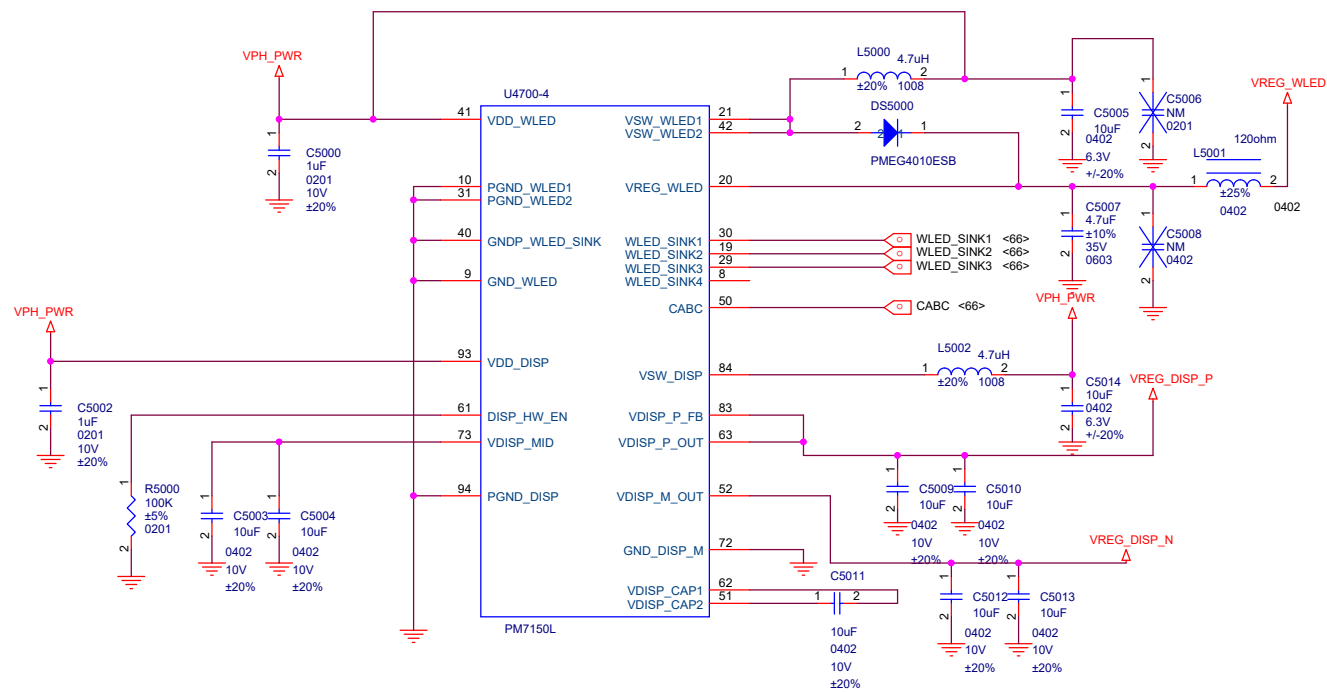

C5011 SHOULD BE CLOSE TO PINS AS POSSIBLE

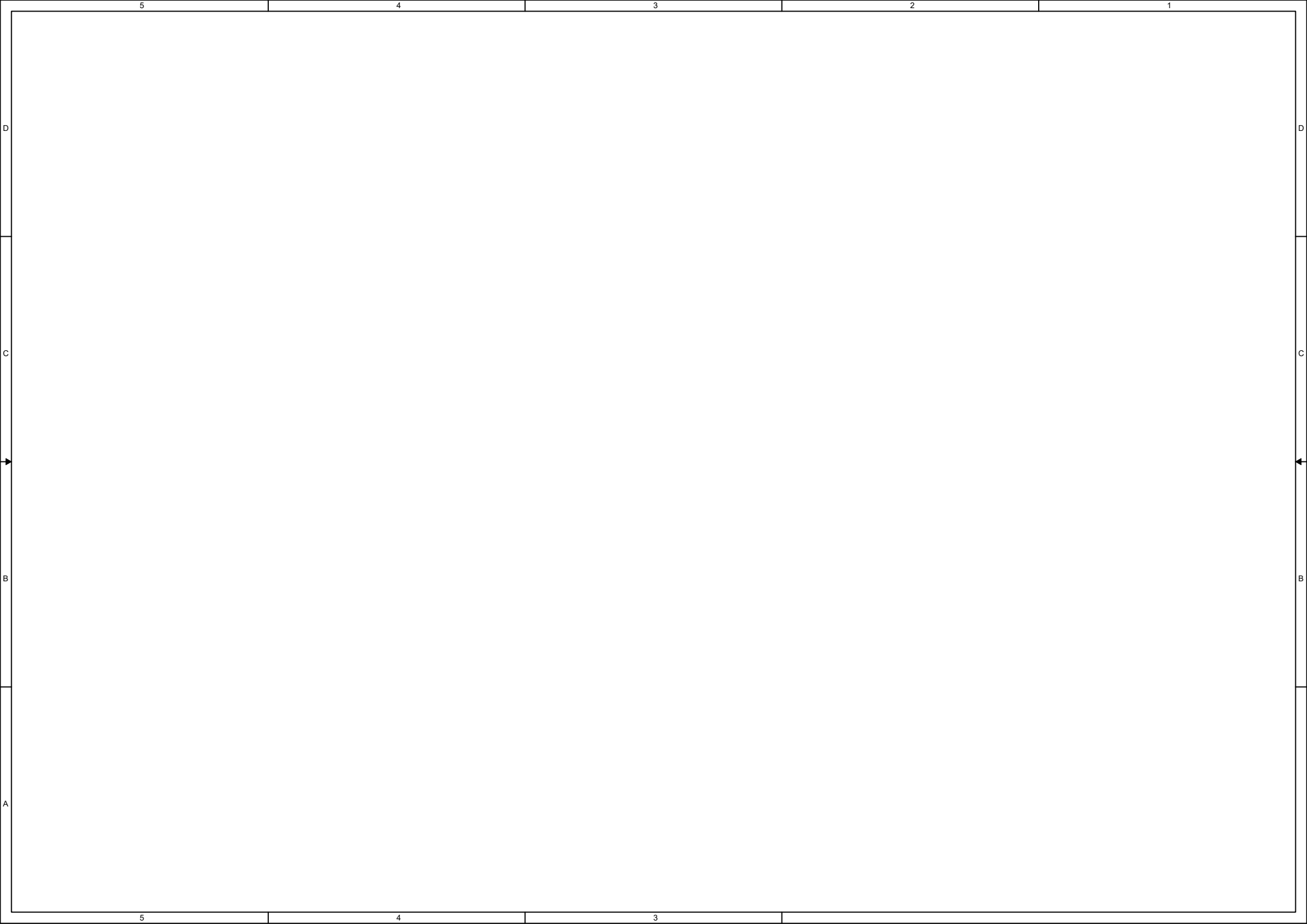

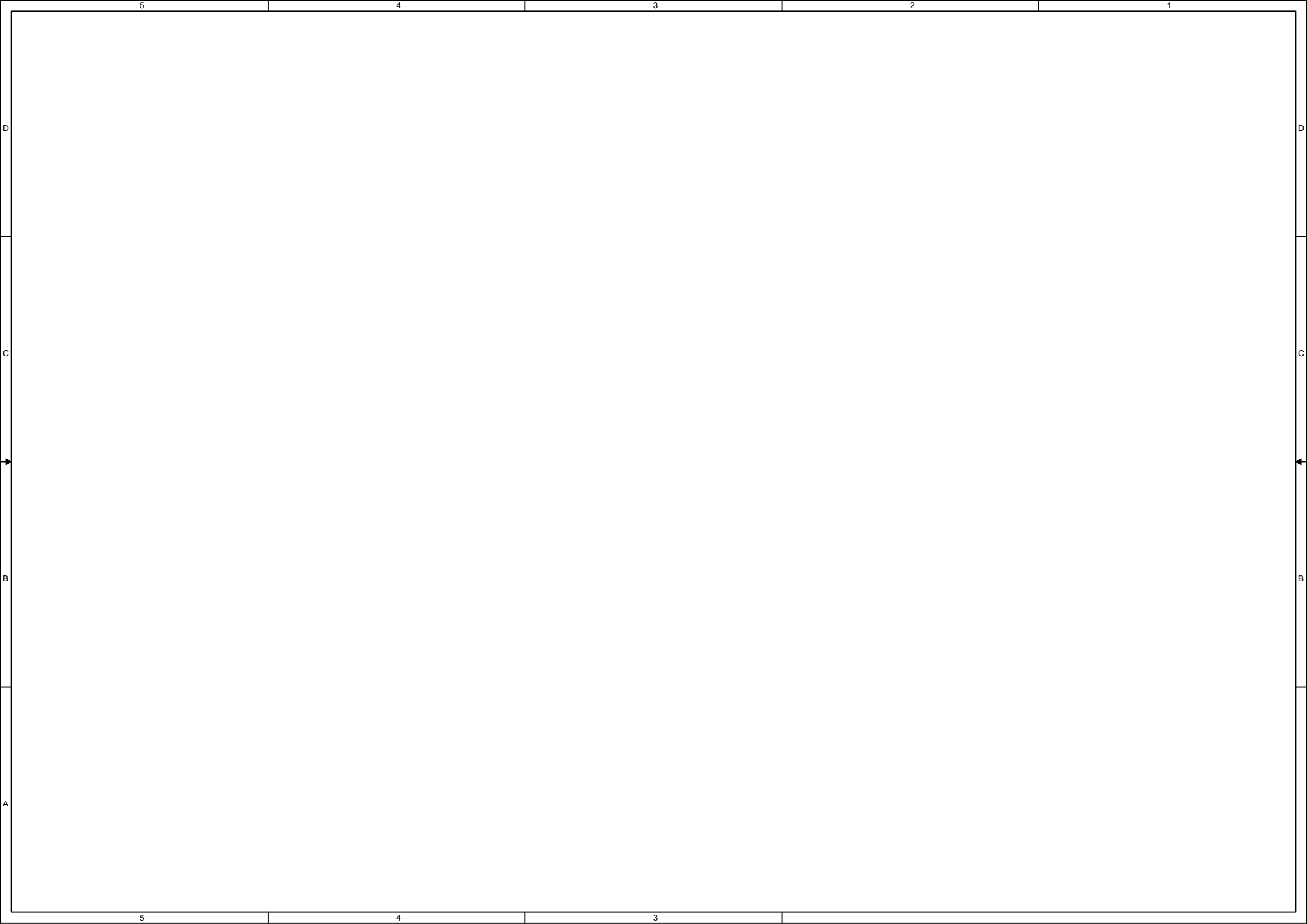

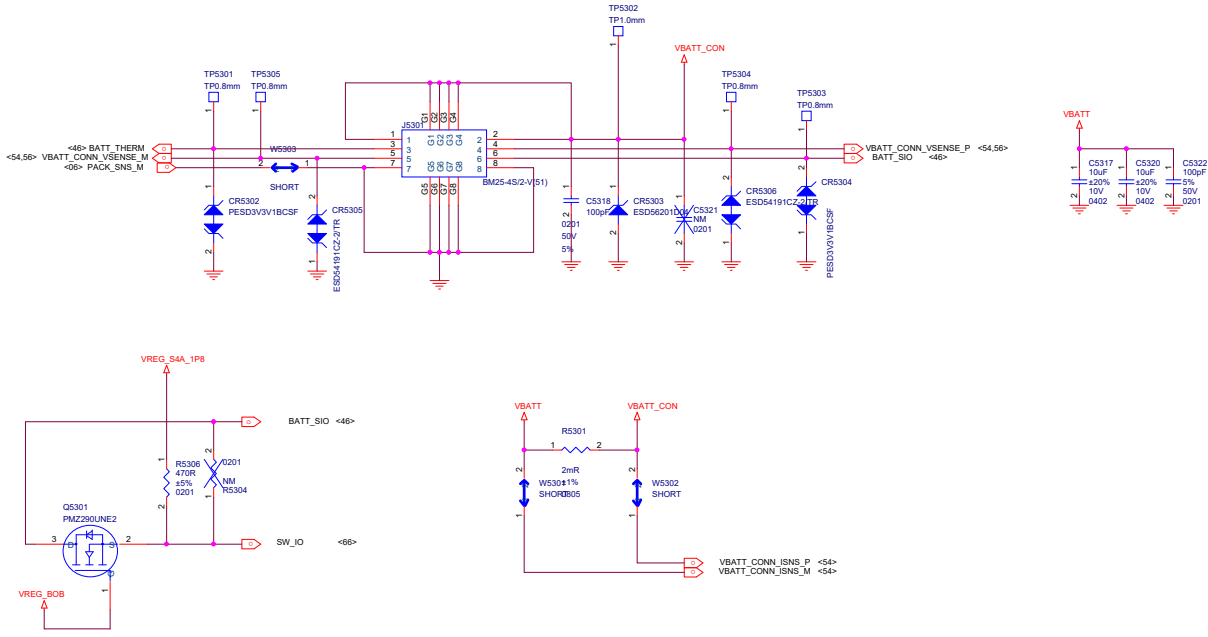
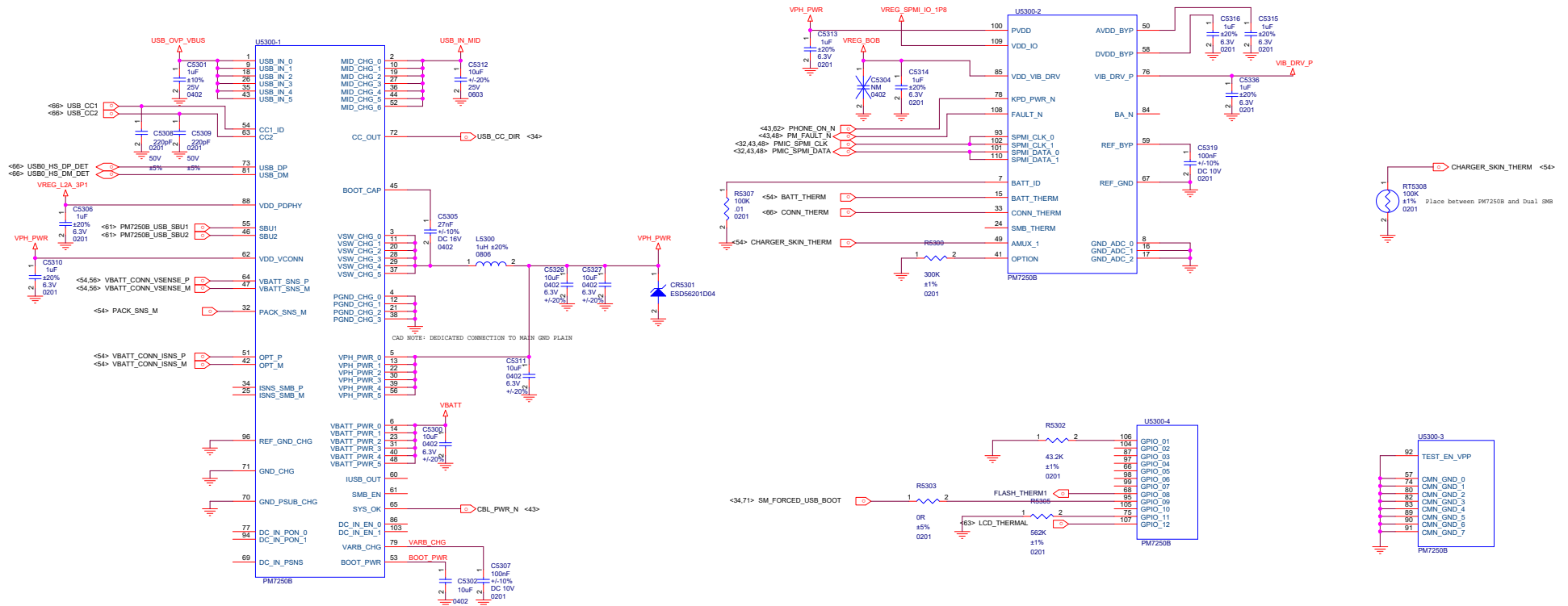



UFS 2.1

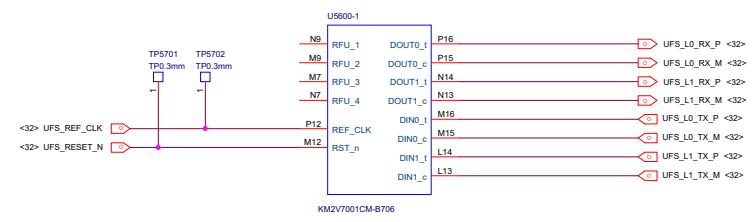

LPDDR4 / 4x

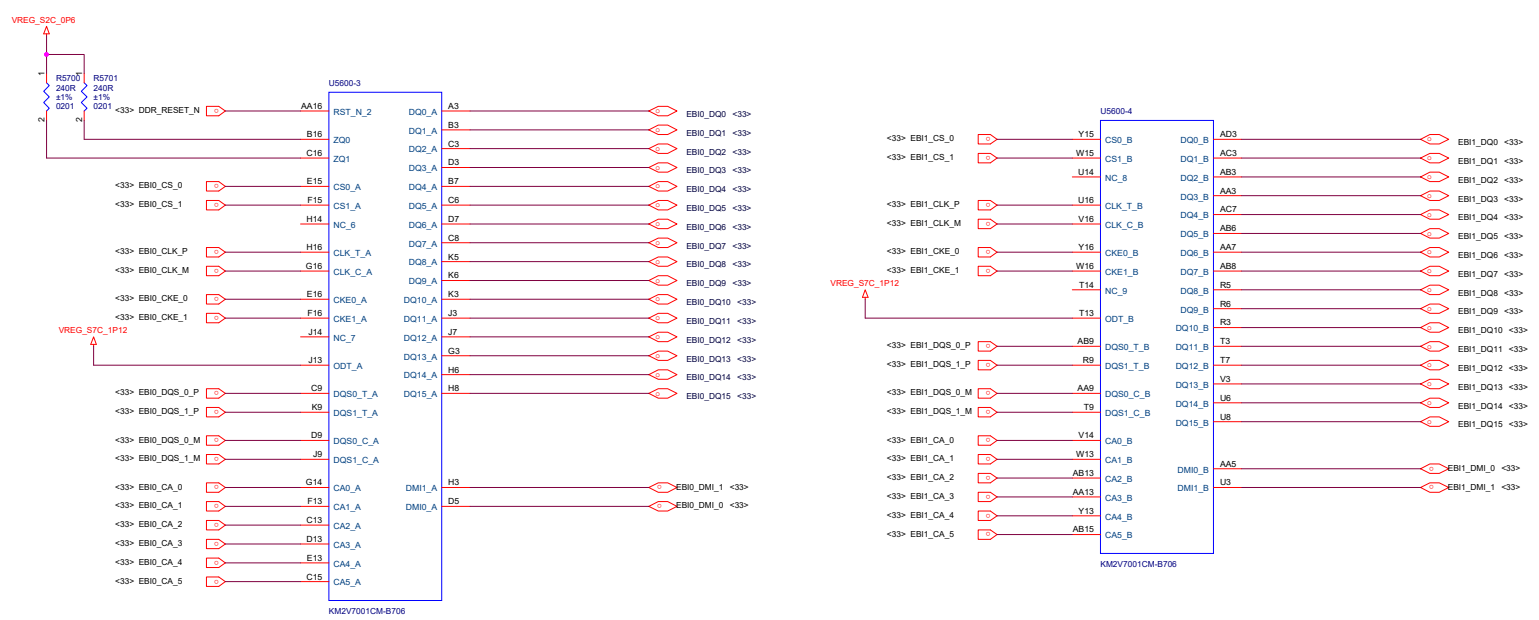

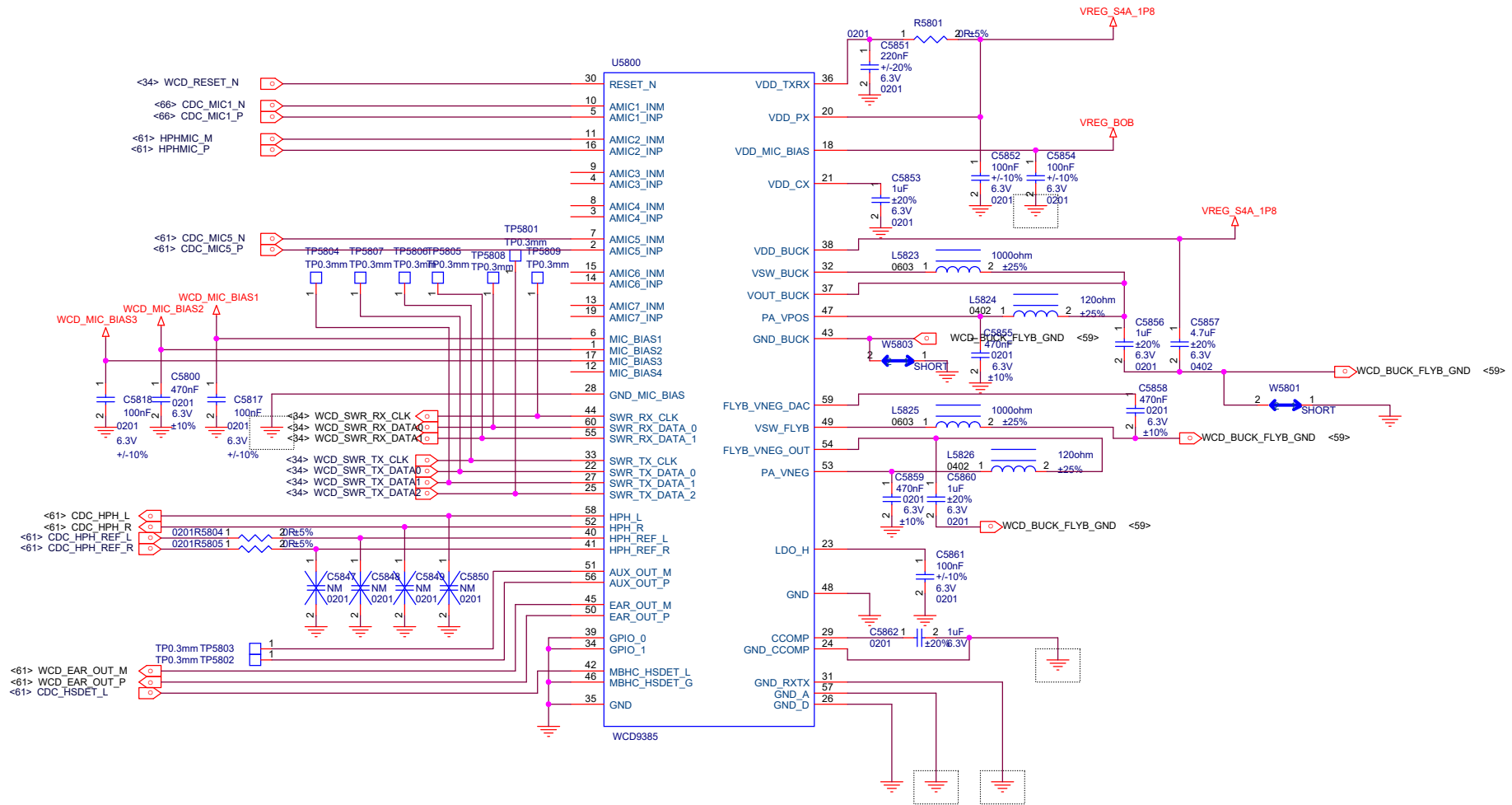

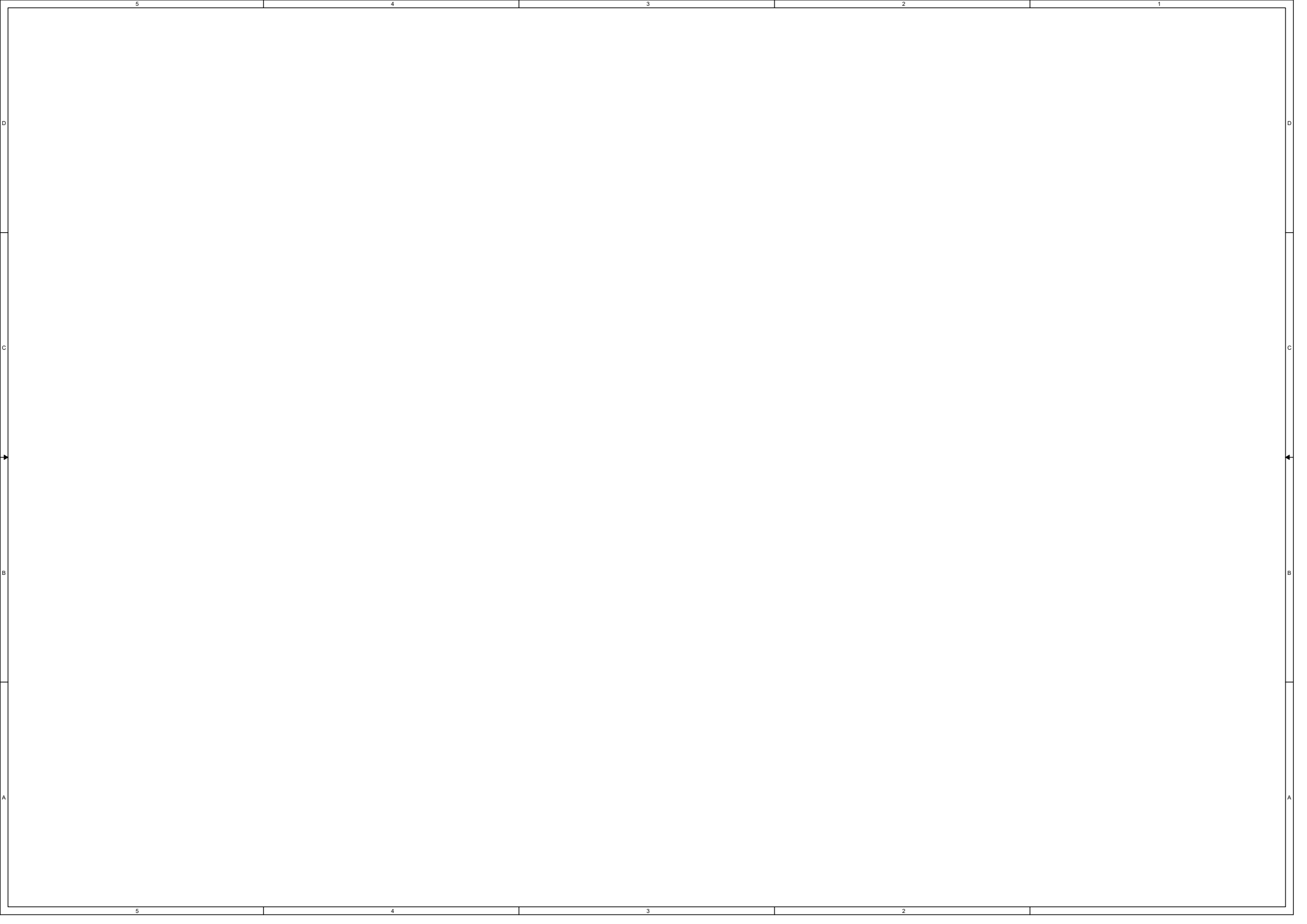

AUX MIC

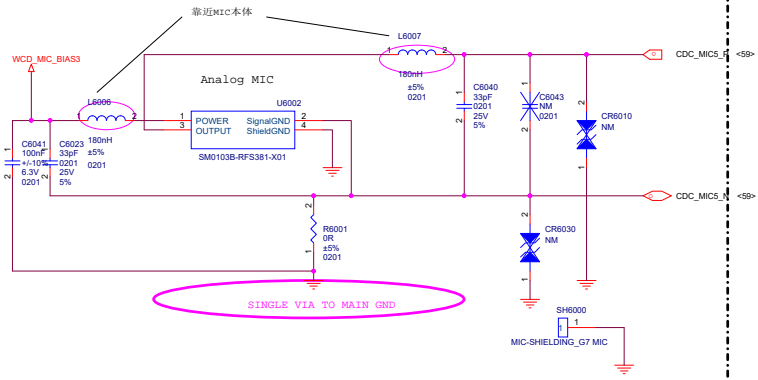

SPKR PA

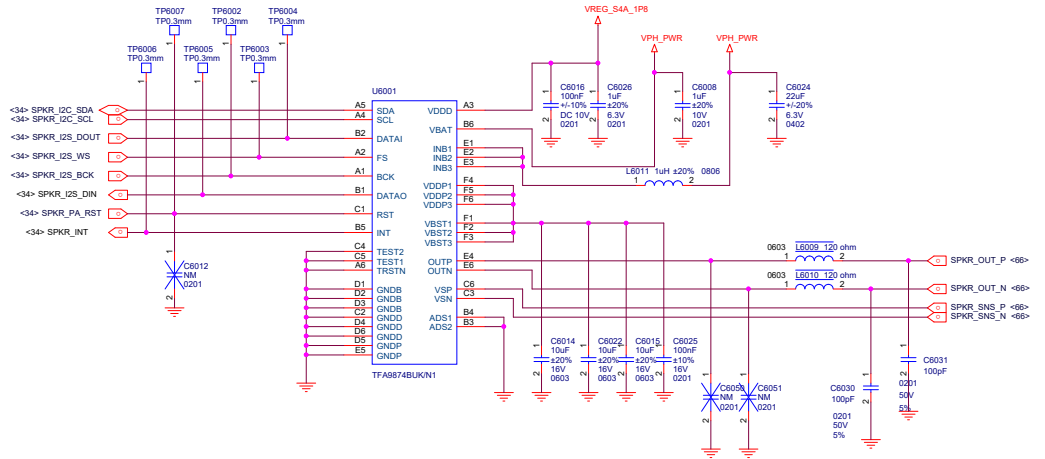

Receiver

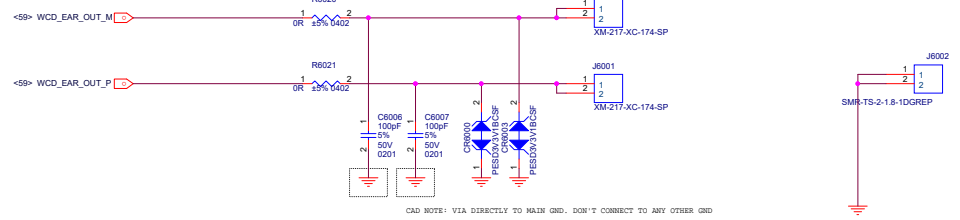

UART SWITCH

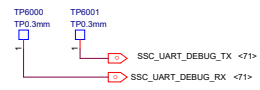

UART_LOG/LPD

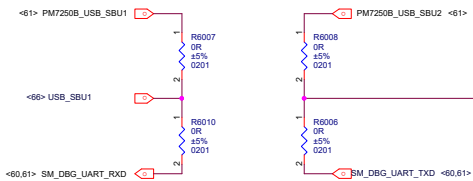

器件放到笼子外

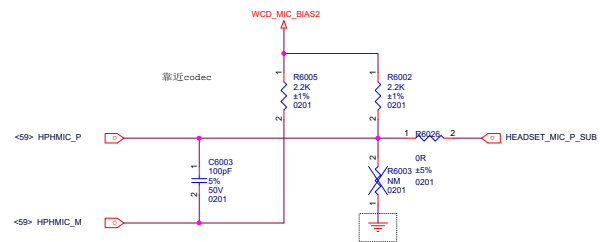

L+P-sensor

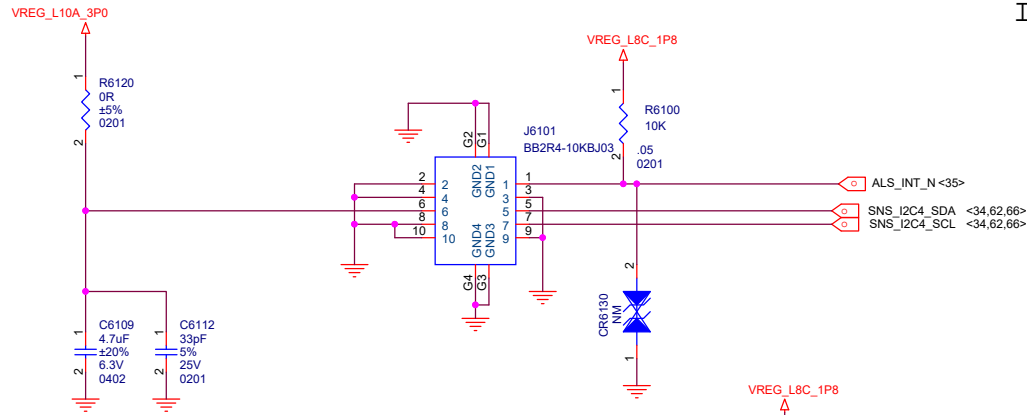

INFARED

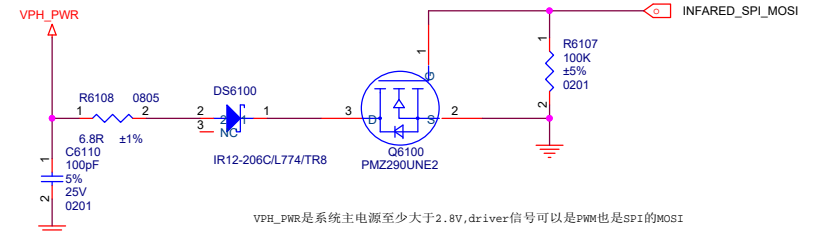

VPH_PWR是系统主电源至少大于2.8v,driver信号可以是PWM也是SPI的MOSI

A+G

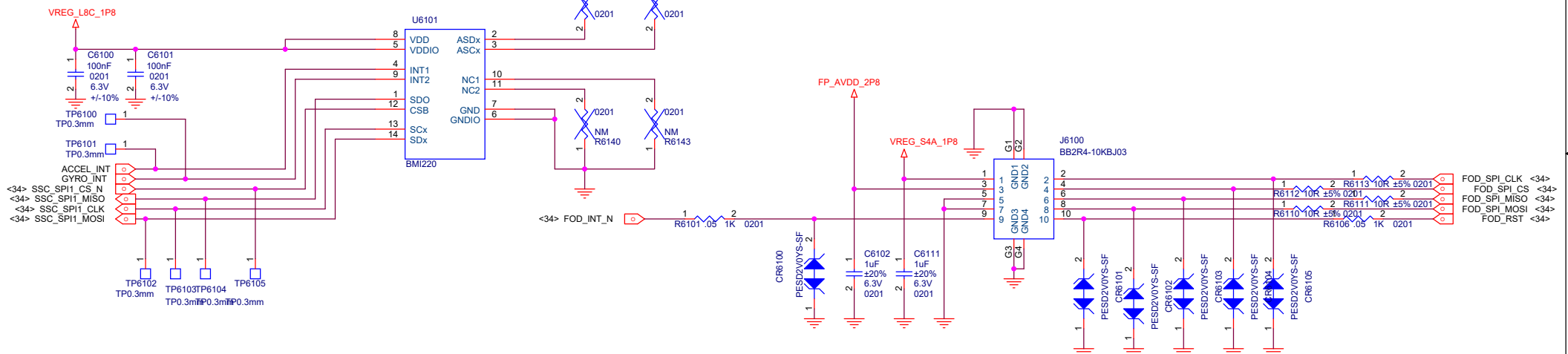

Sidekey

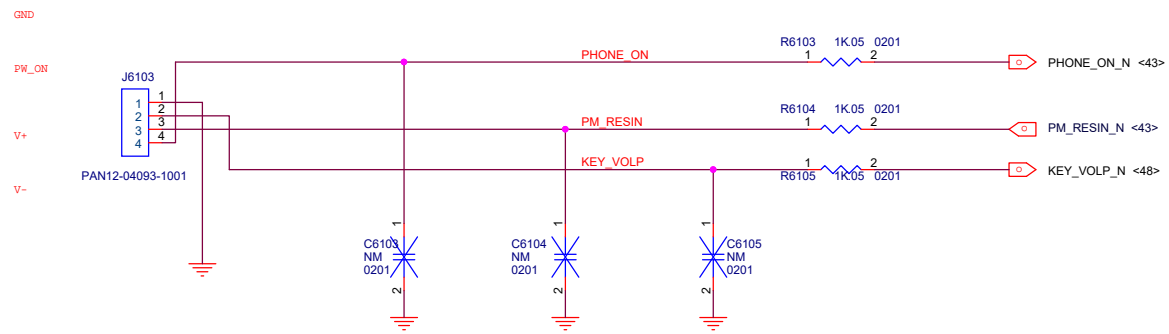

FP

COMPASS

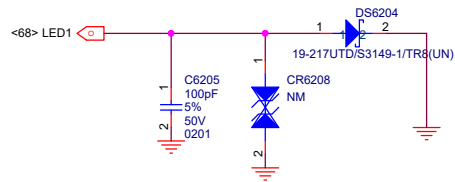
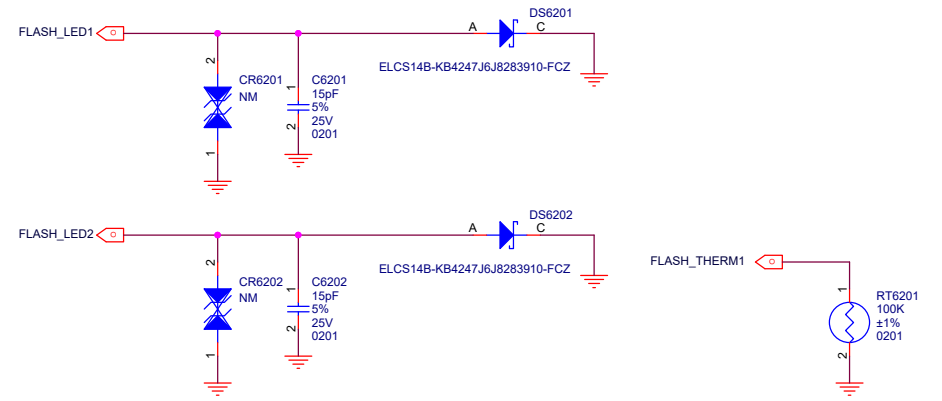
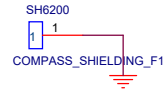
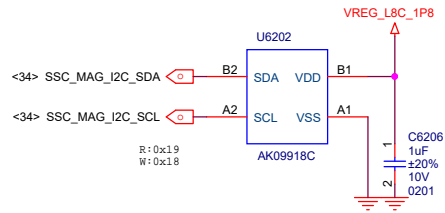

D

C

B

A

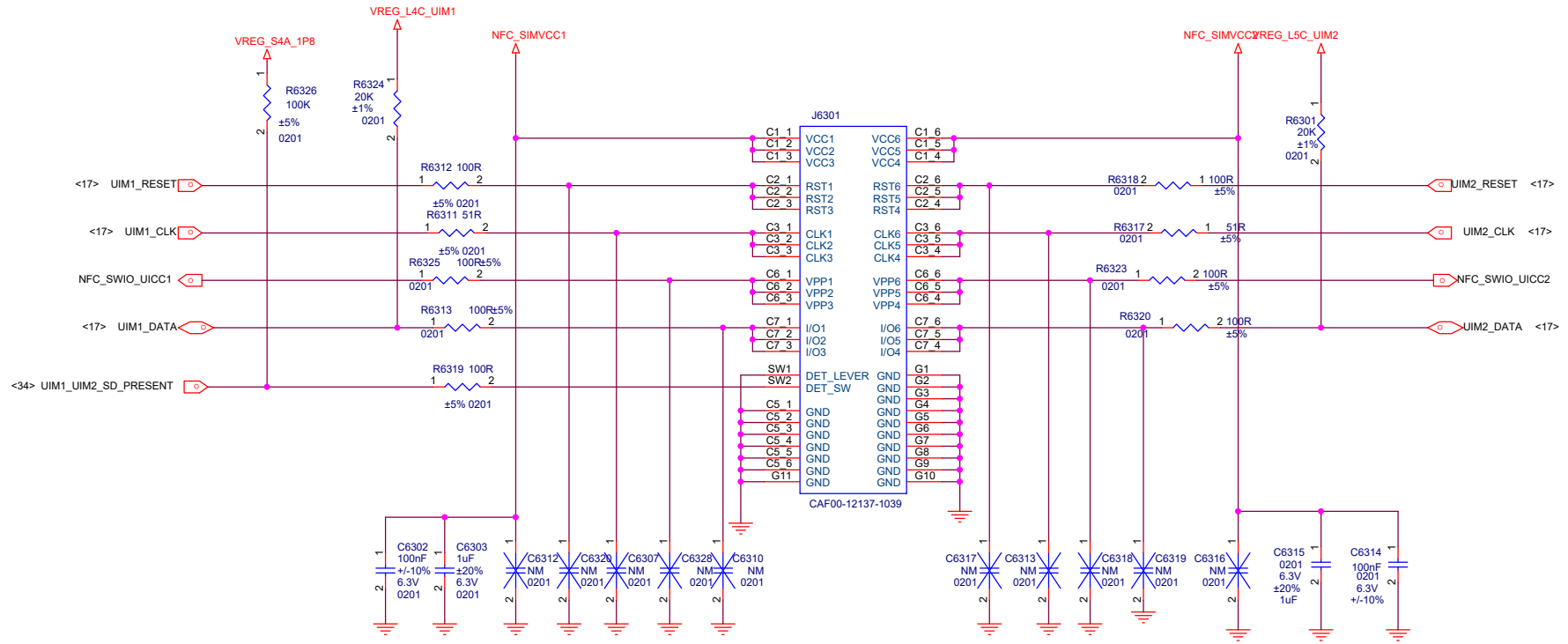

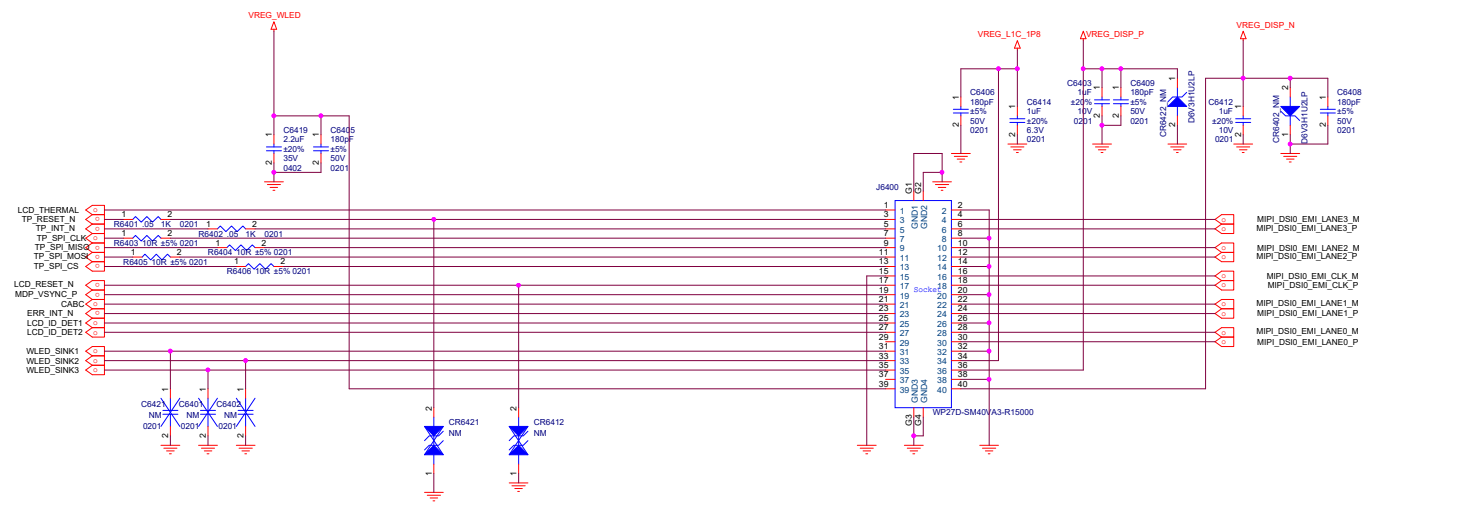
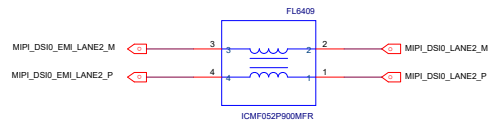
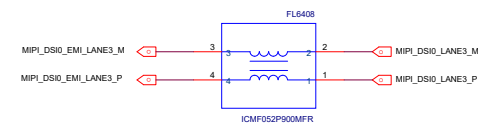
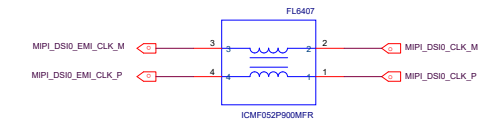
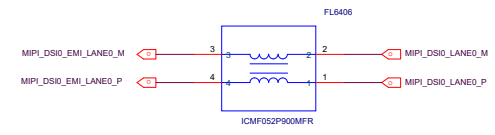
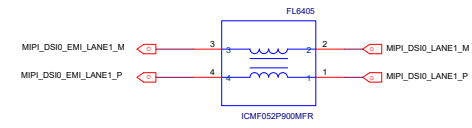

2M DEEP

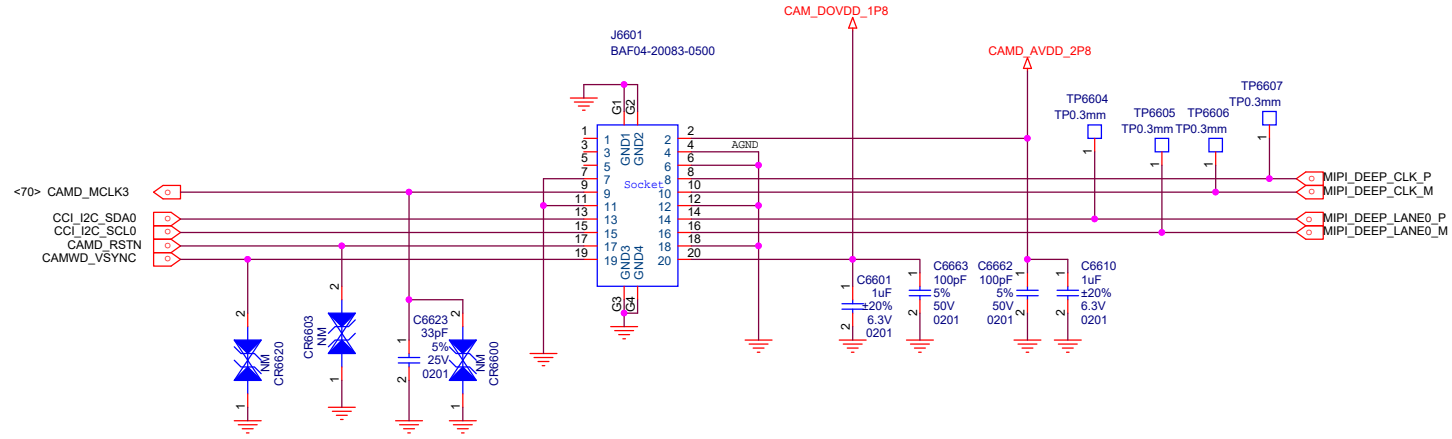

5M MICRO

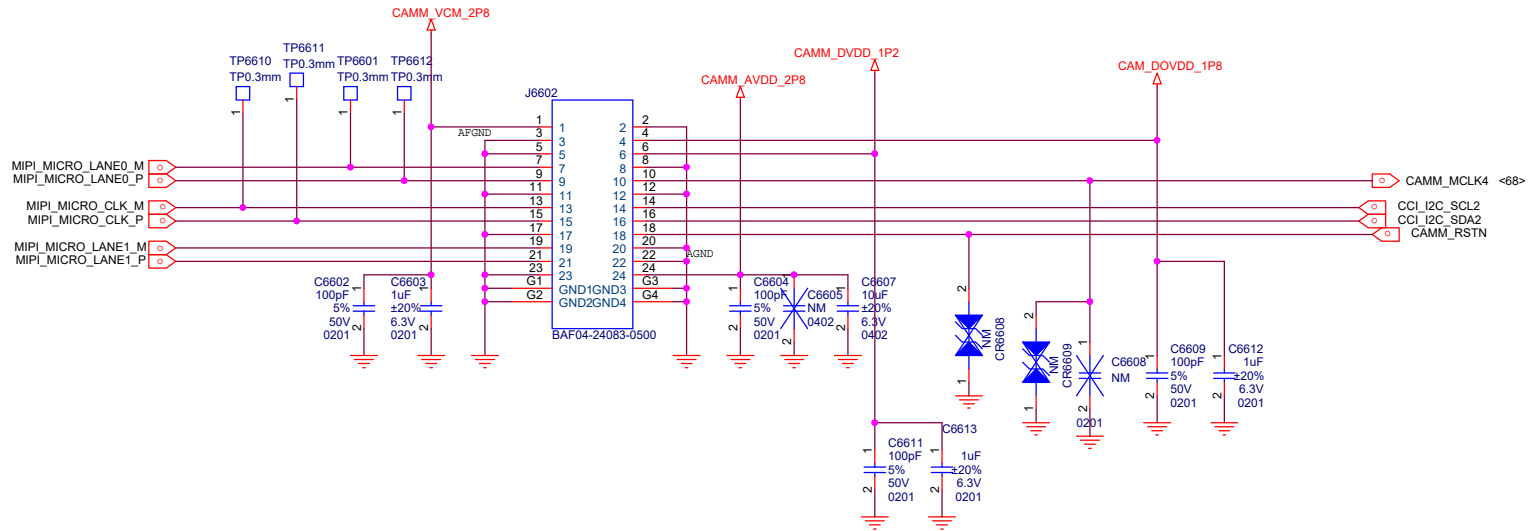

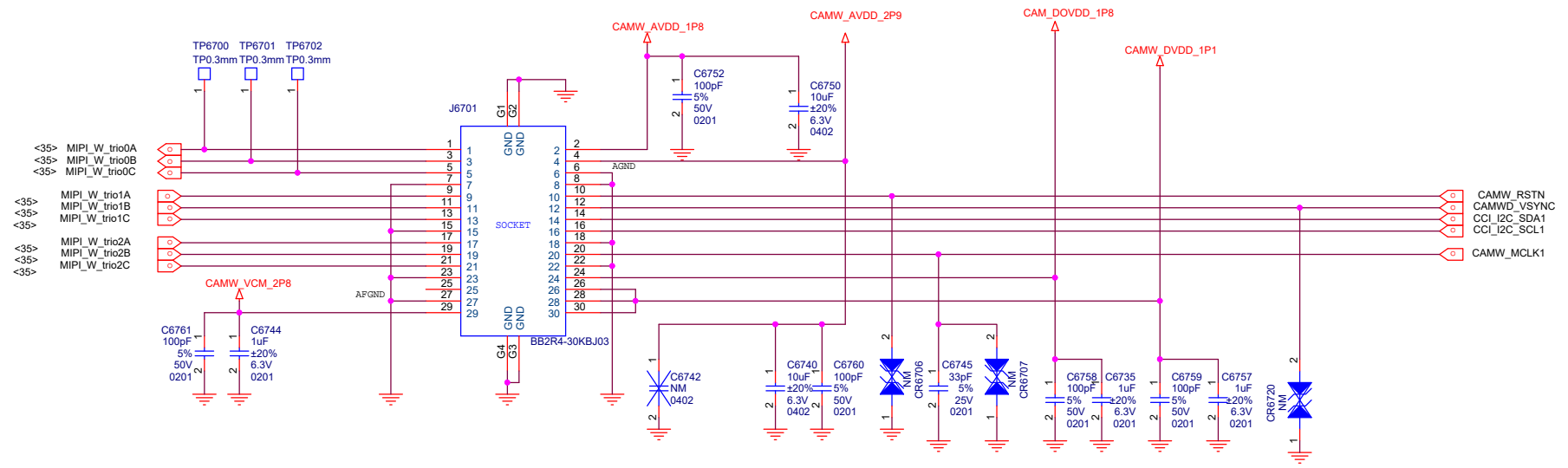

20M FRONT

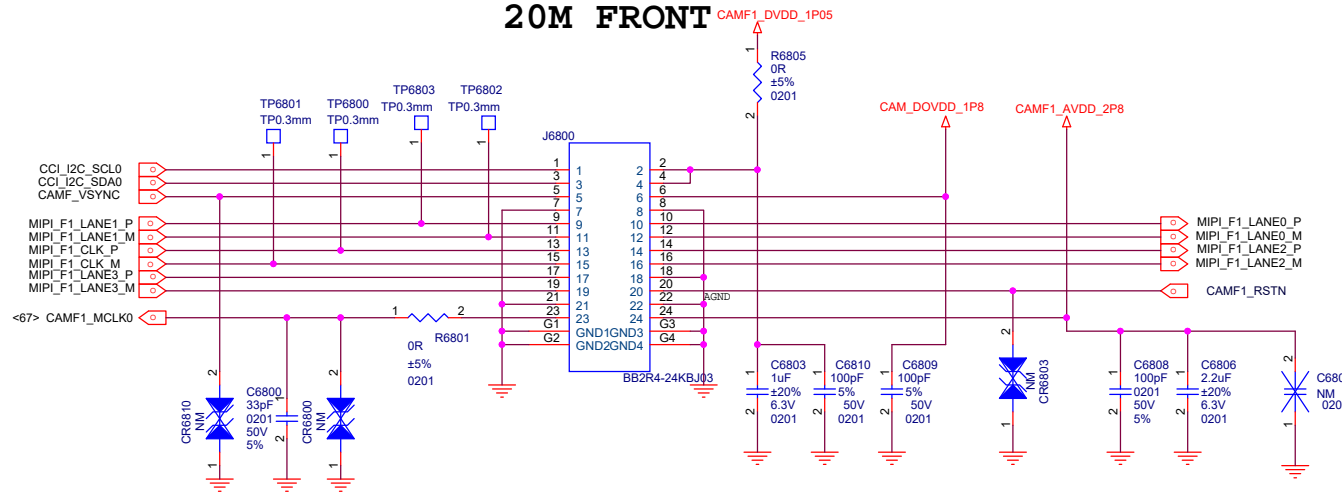

2M FRONT

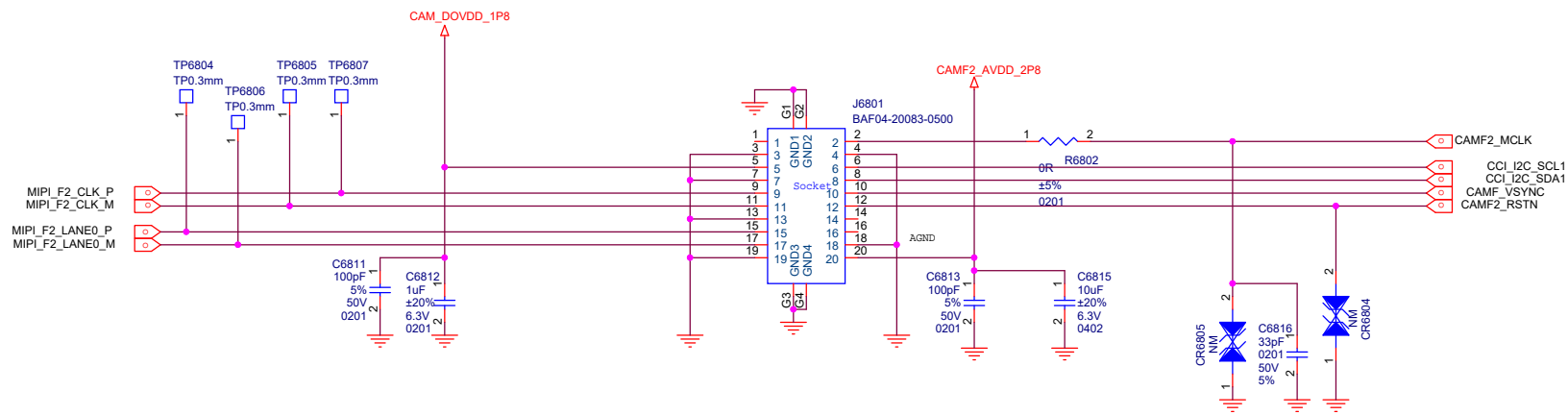

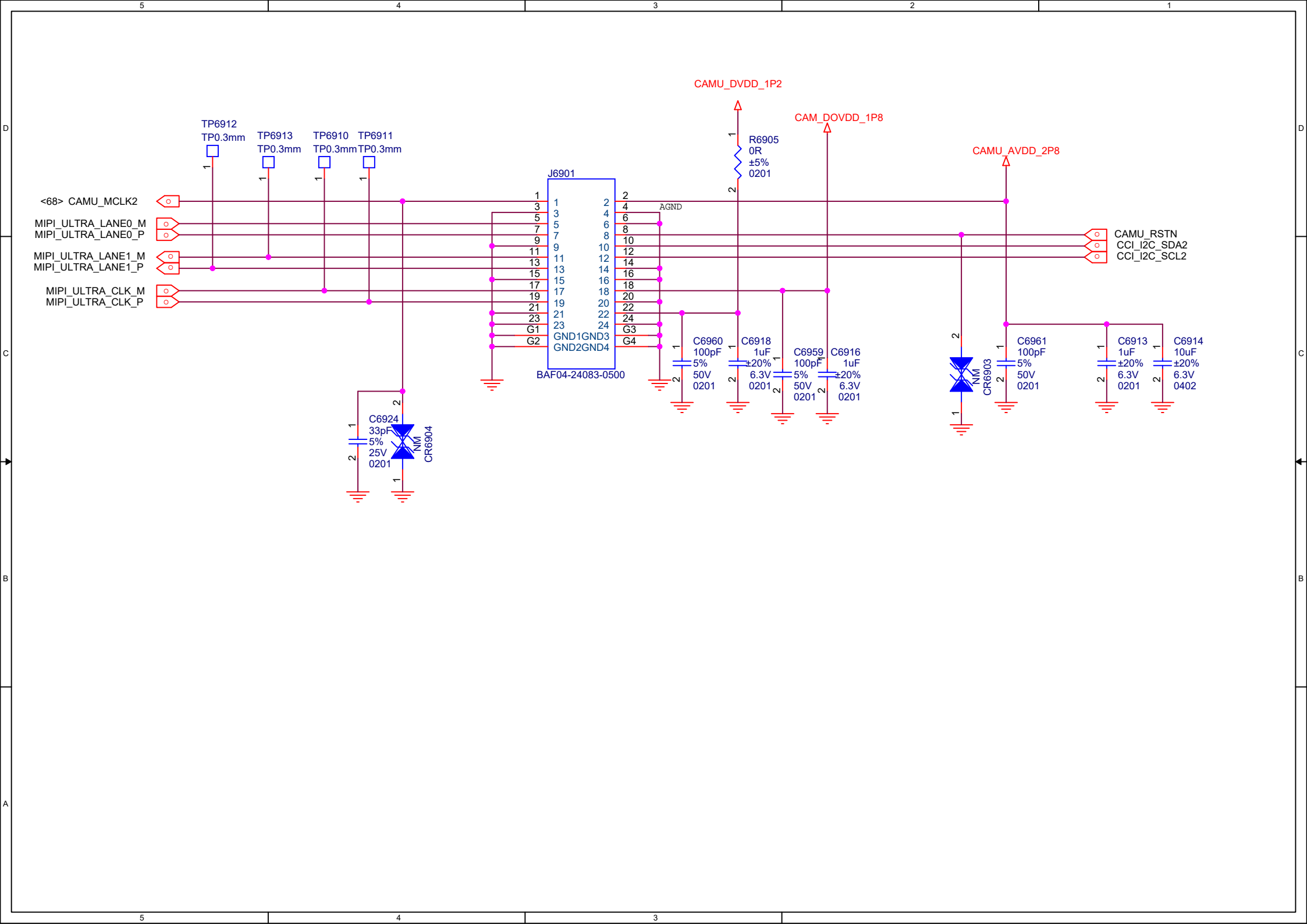

WIDE

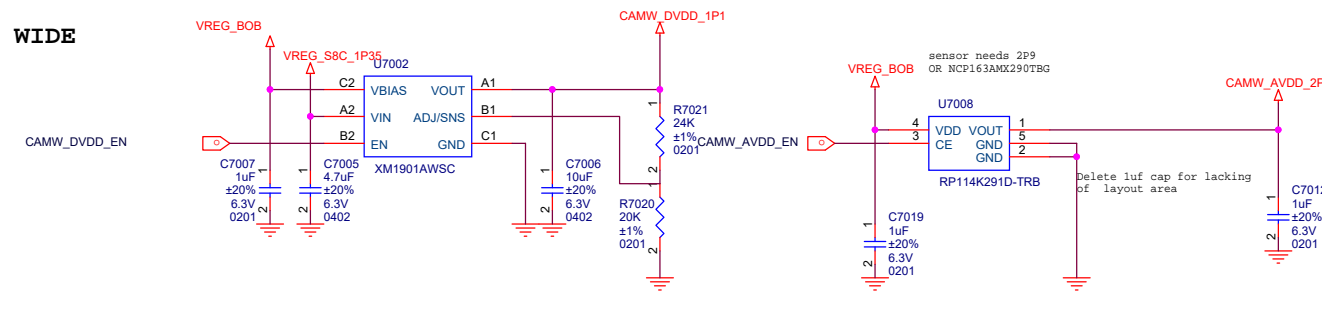

DEEP

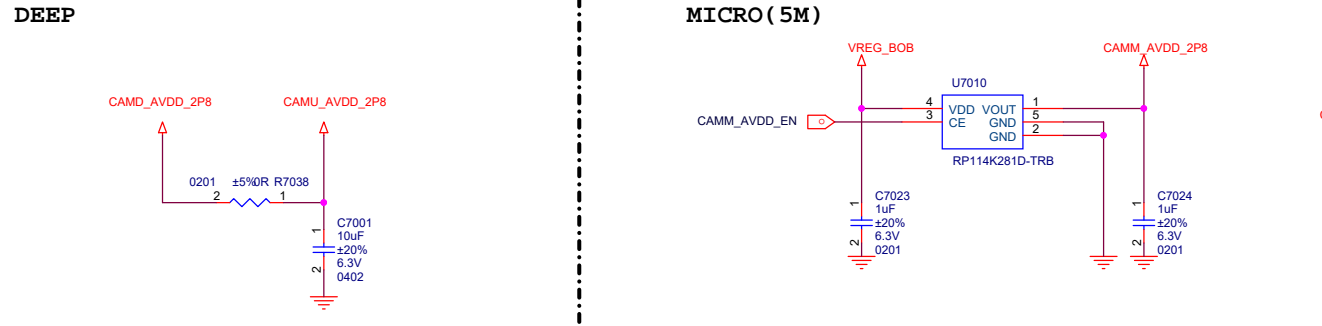

FRONT

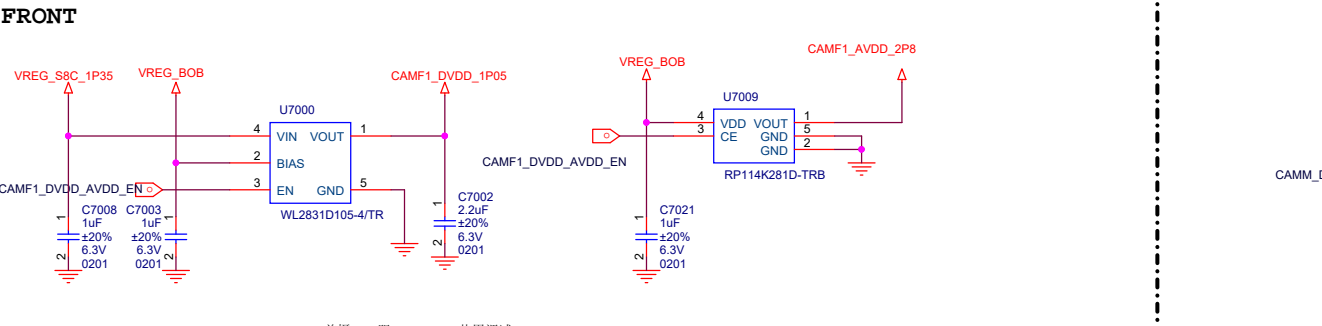

前接DVDD跟Ultra DVDD共用测试

ULTRA

