

红外地弹片

cable夹

屏蔽罩 屏蔽罩 螺母 长地弹片

camera地弹片

分级天线座地弹片

DRX_ANT_GND

TUNER_CTR

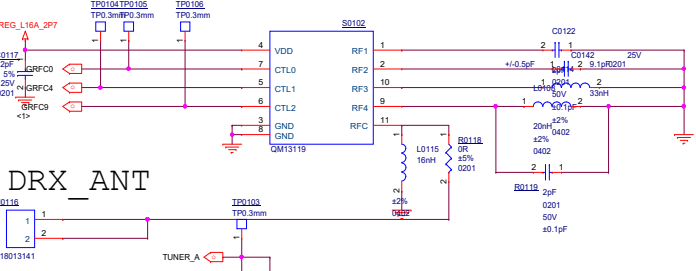

CLOSE TO DRX ANT

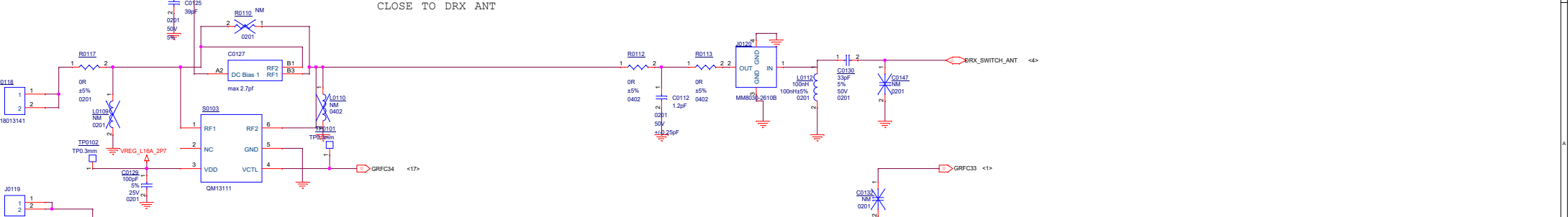
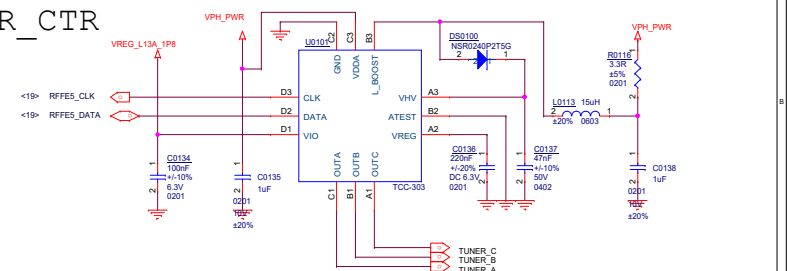

Title		E2	
Size	A2	Document Number	ANT_CONDUCTORSWITCH
Date:	Wednesday, January 18, 2018	Sheet	1 of 37

B2&B5&B8

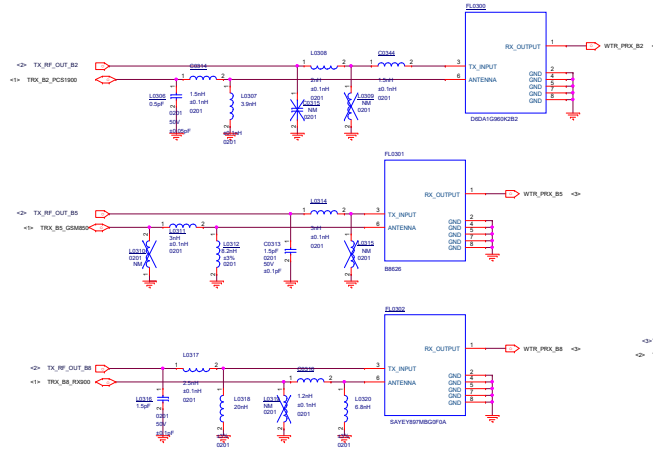

TX B28A

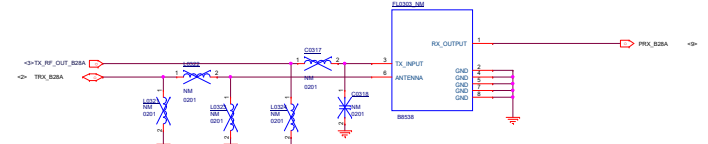

TX B28B

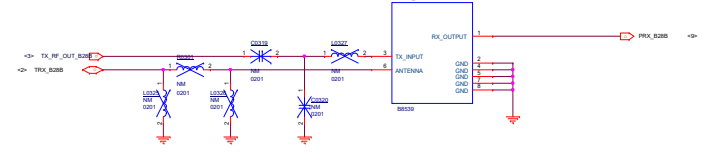

B40

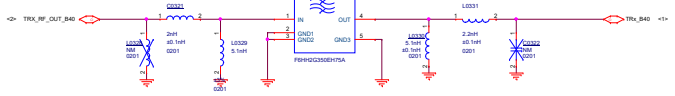

TX B41

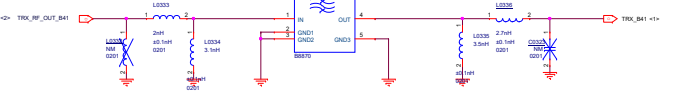

TX TDS



TRI FILTER B34 B39 B41

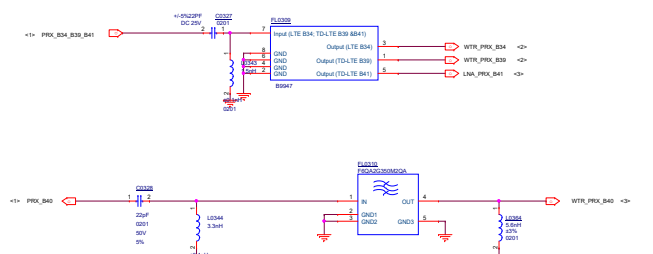

Thermal

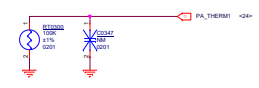

B1&B3

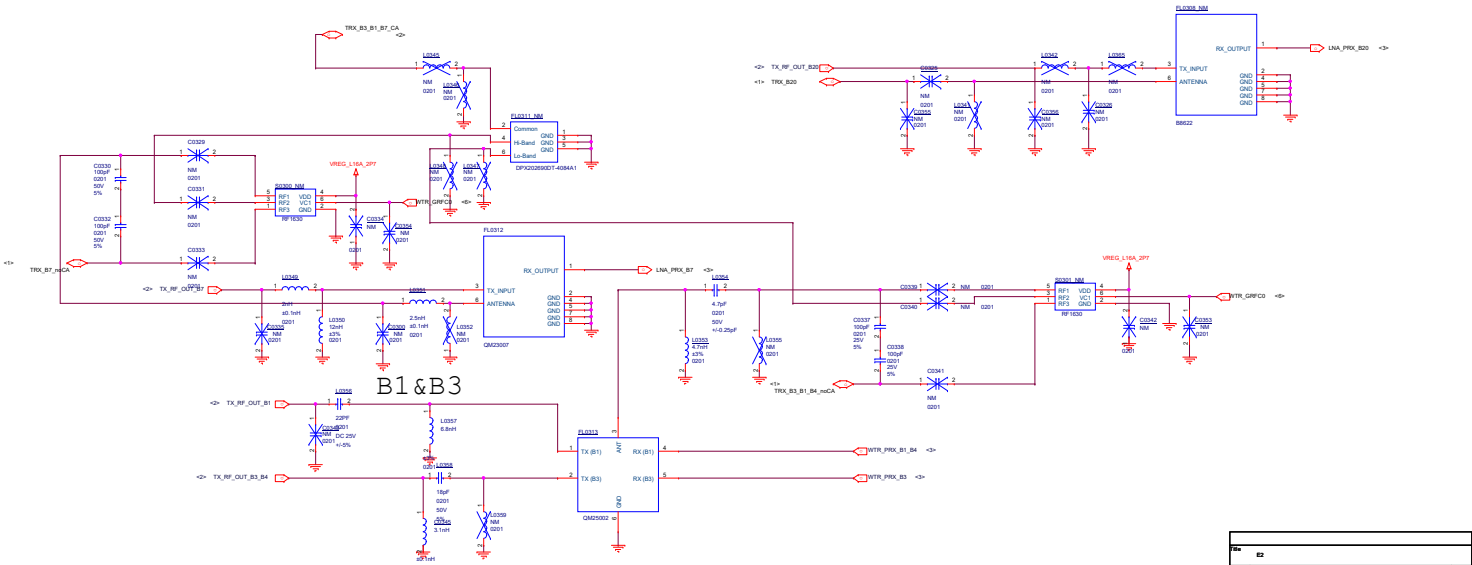

DRX

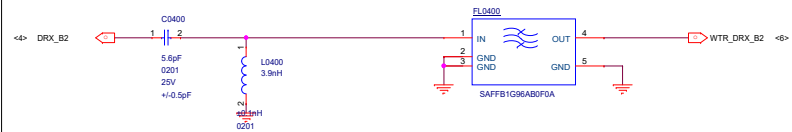

DRX B28

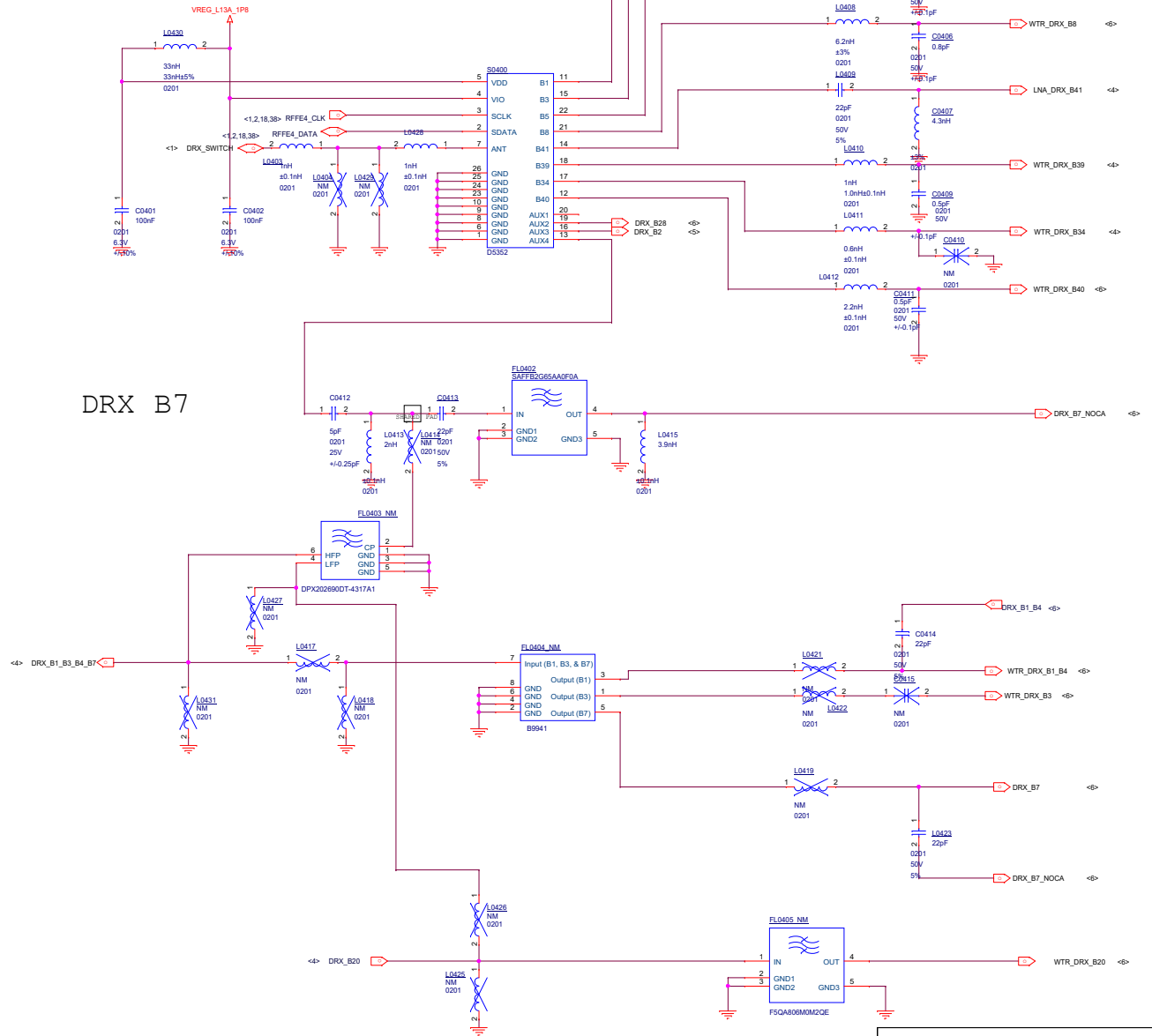
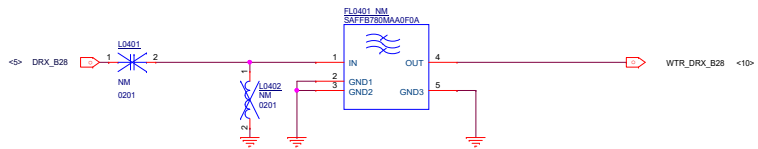

DRX B7

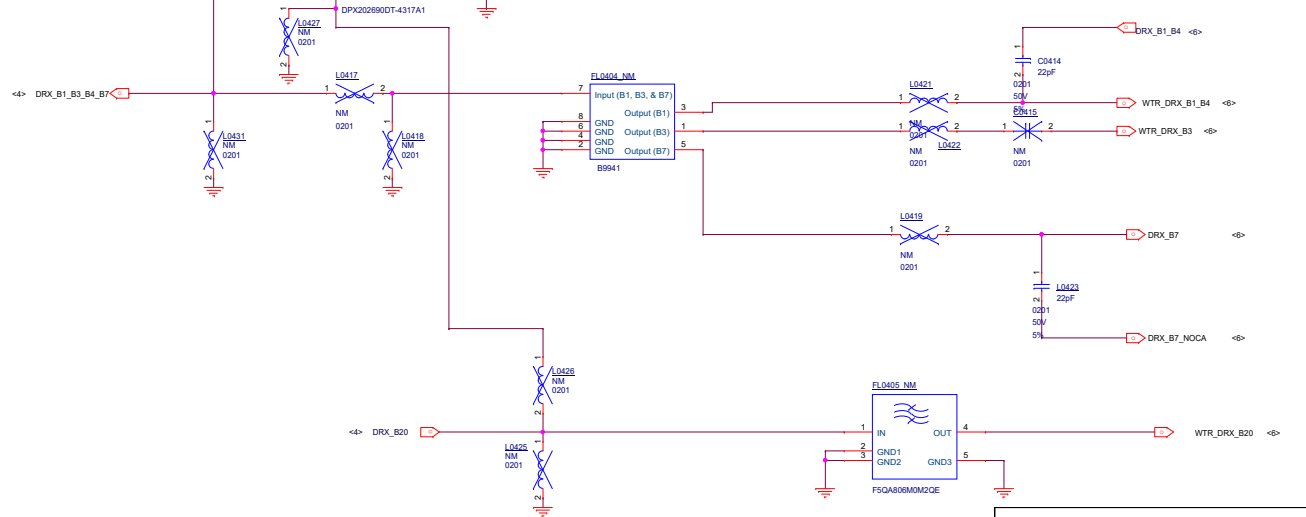

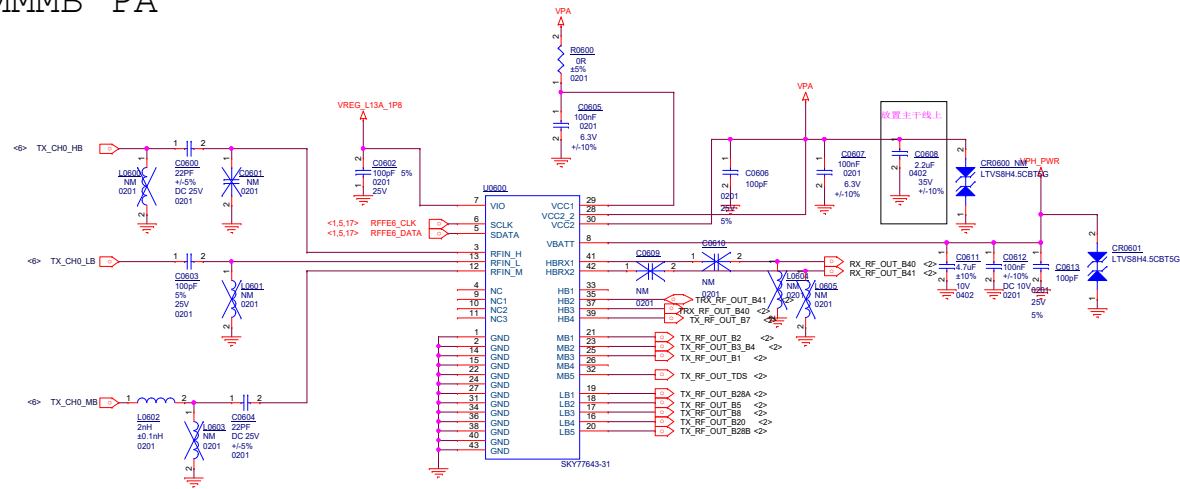

Title		EX	
Size	A2	Document Number	FILTERS&CSMBOOKDRX_B
Date:	Wednesday, January 16, 2019	Sheet	4 of 37
Rev	00		

MMMB PA

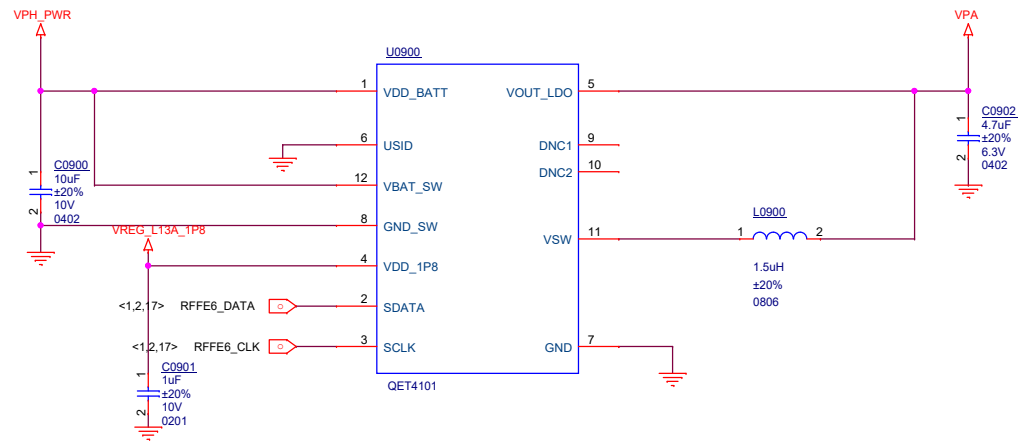

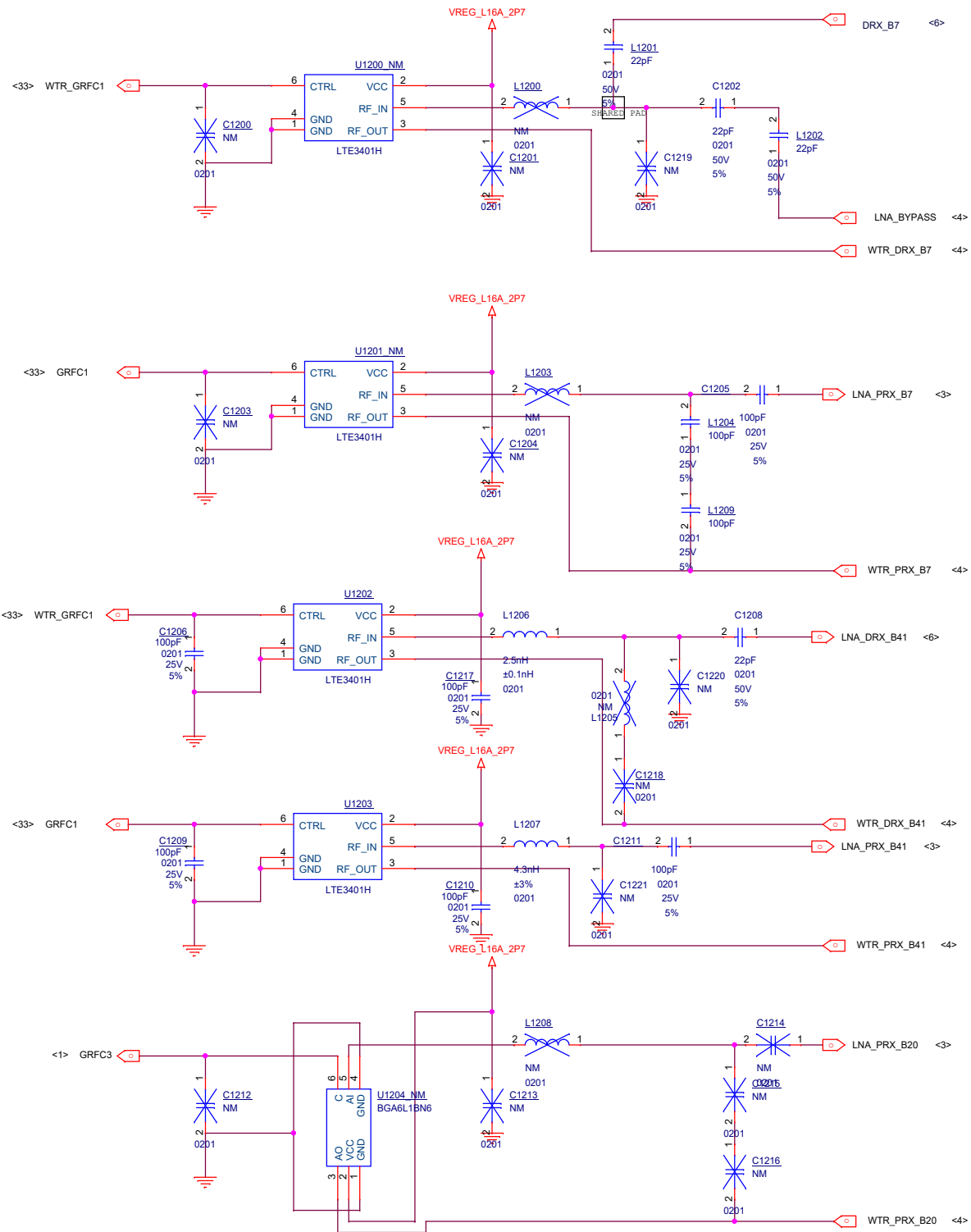



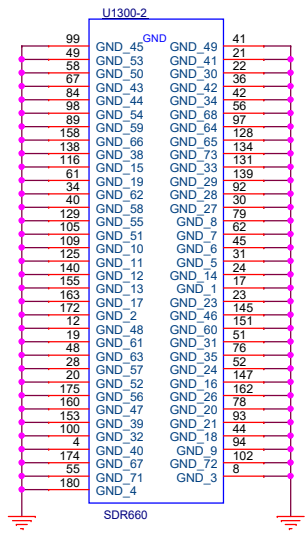
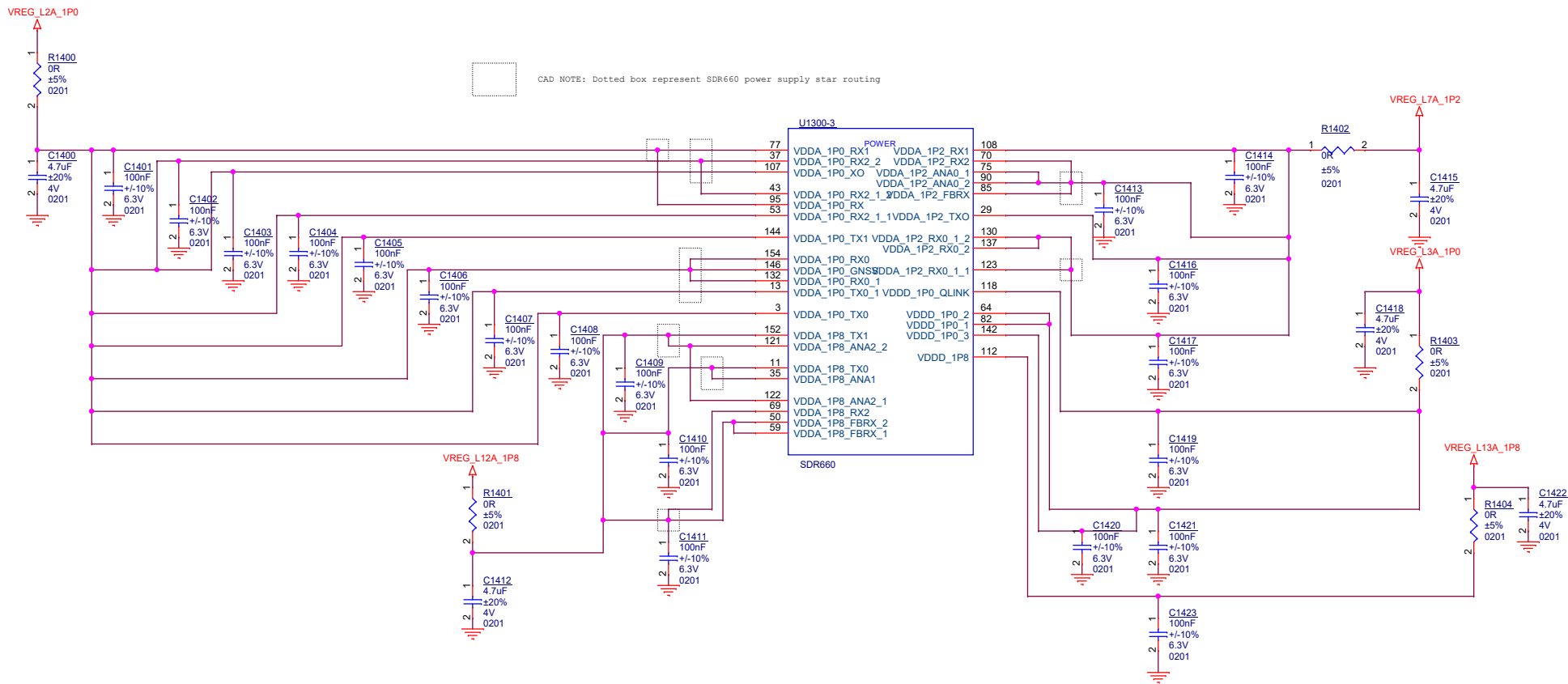

Title		F1 MAIN	
Size	A3	Document Number Reserved(for LNA)	
Date:	Wednesday, January 16, 2019		Sheet 12 of 70

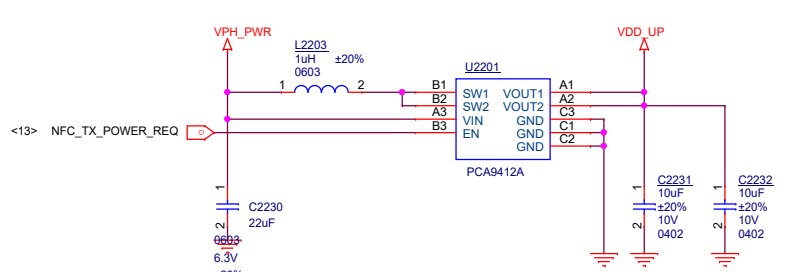
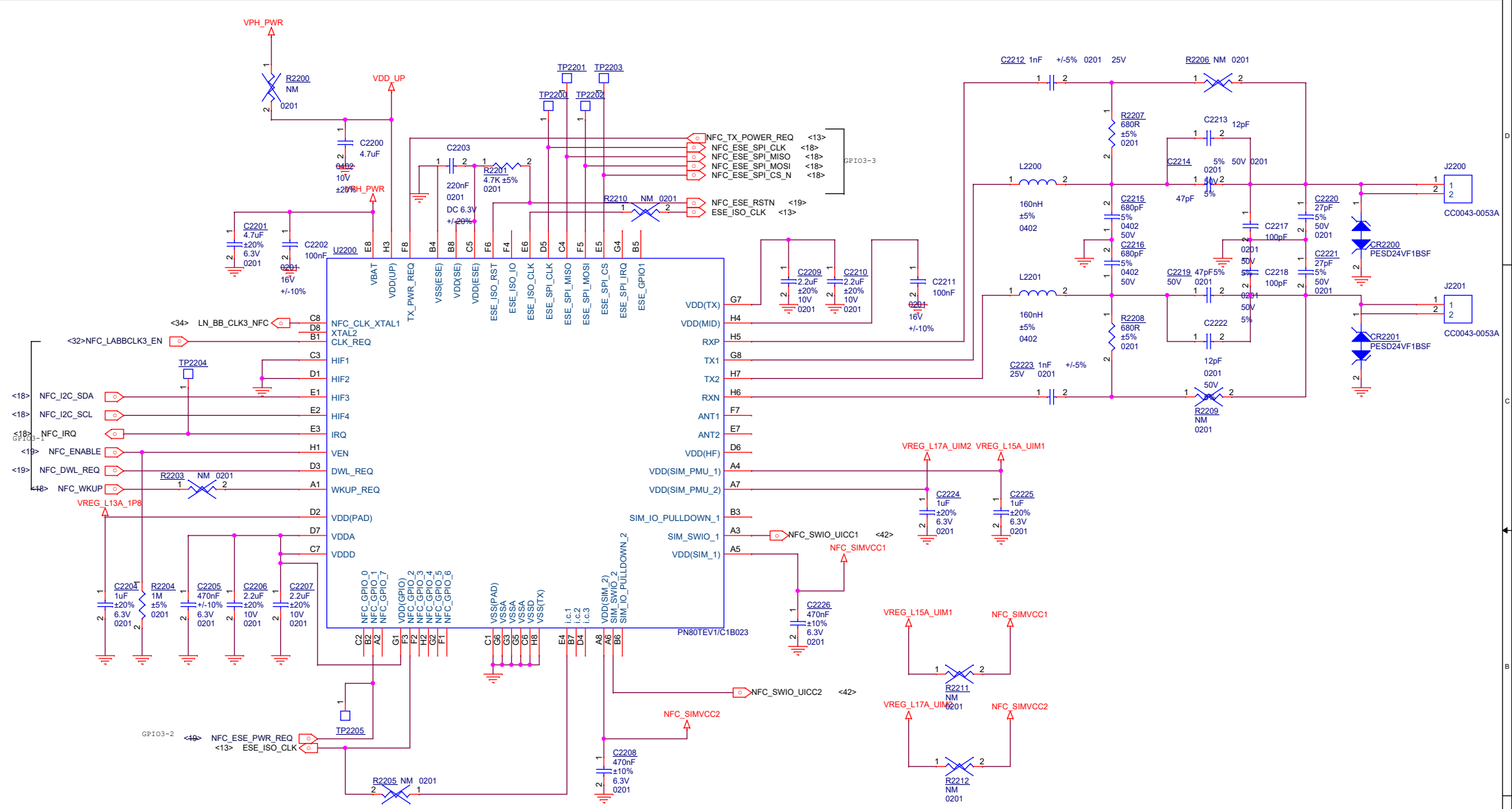



Title		F1 MAIN			
Size	A3	Document Number	Reserved(for PA)		
Date:	Wednesday, January 16, 2019	Sheet	23 of 71	Rev	P0

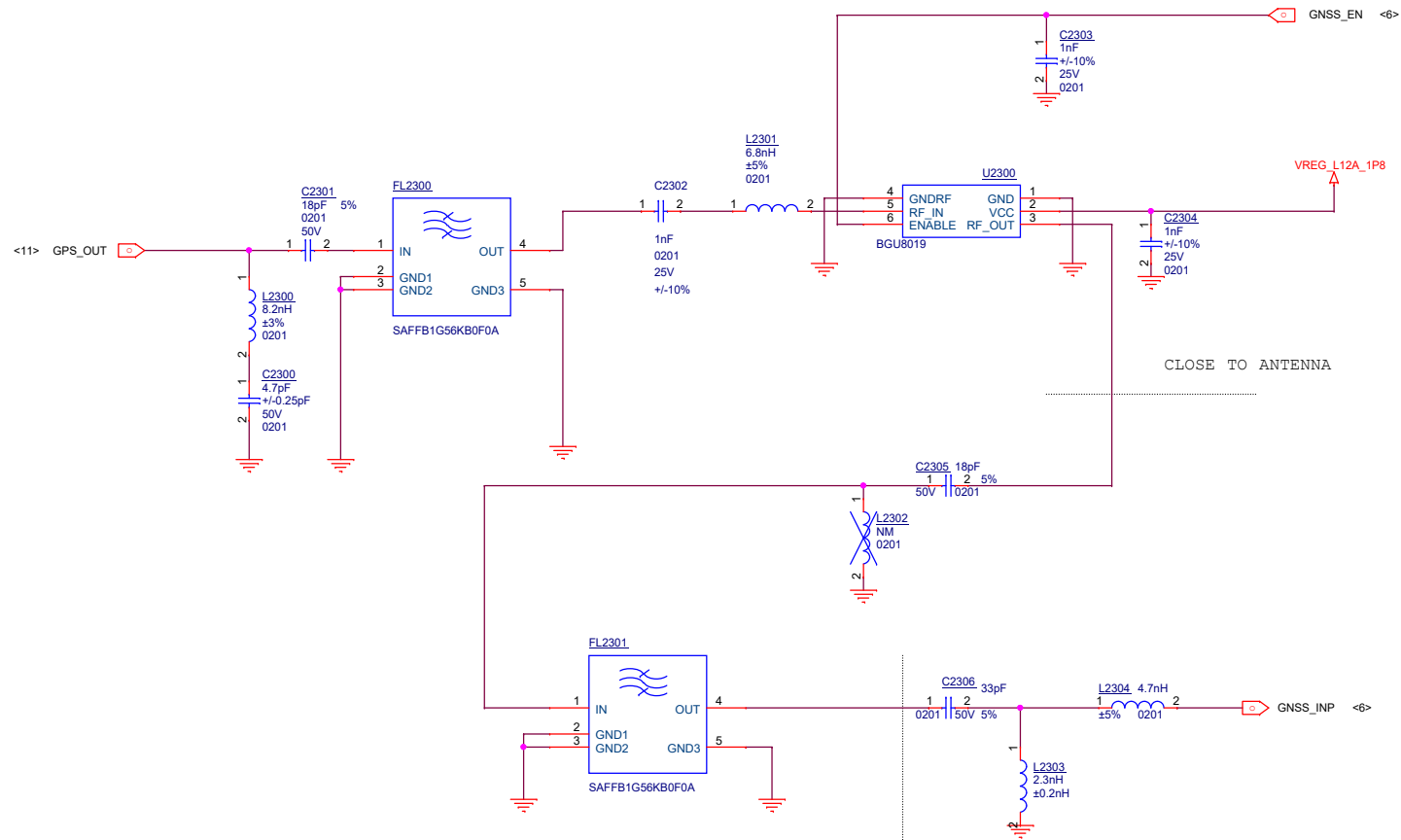

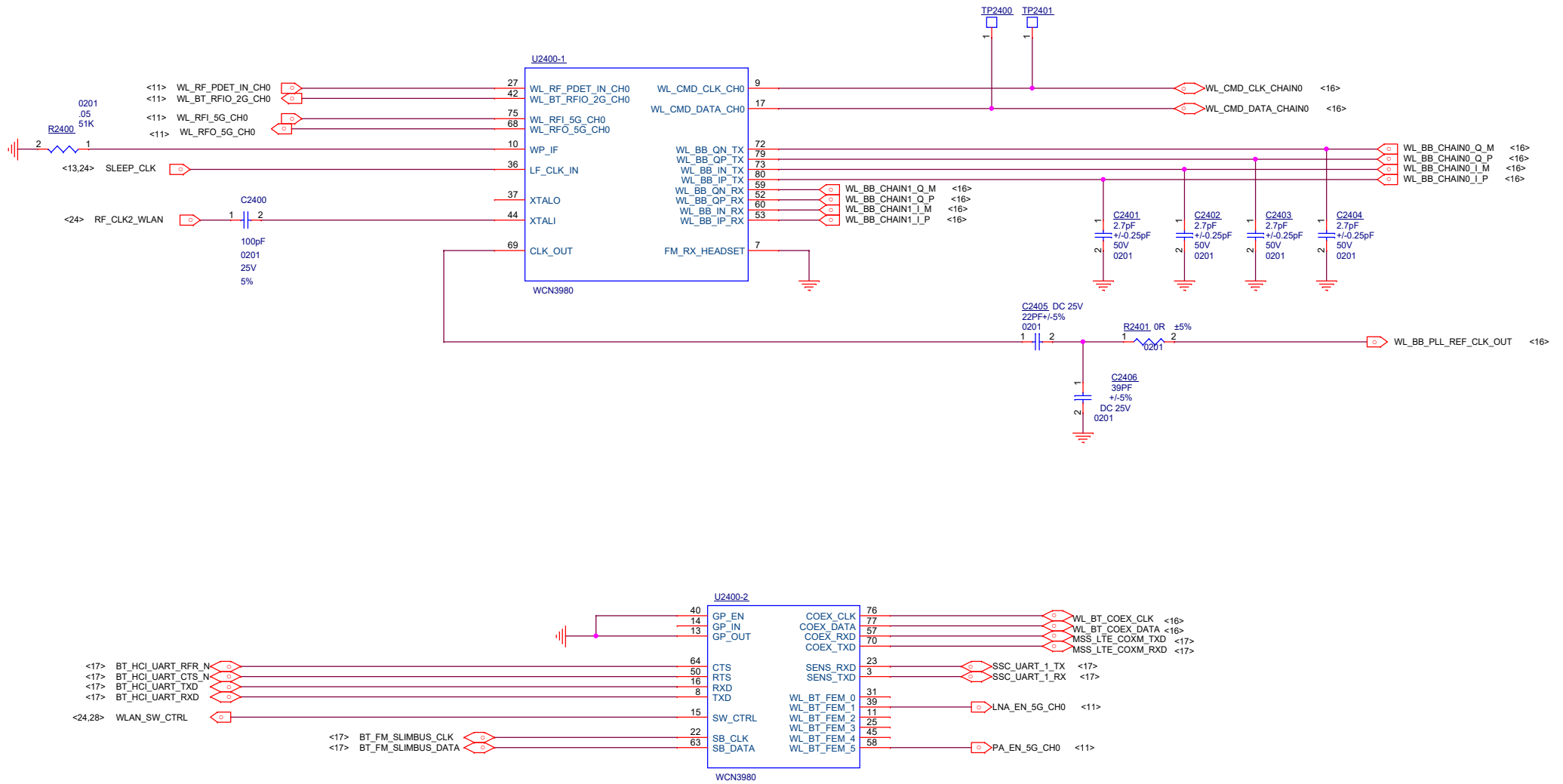

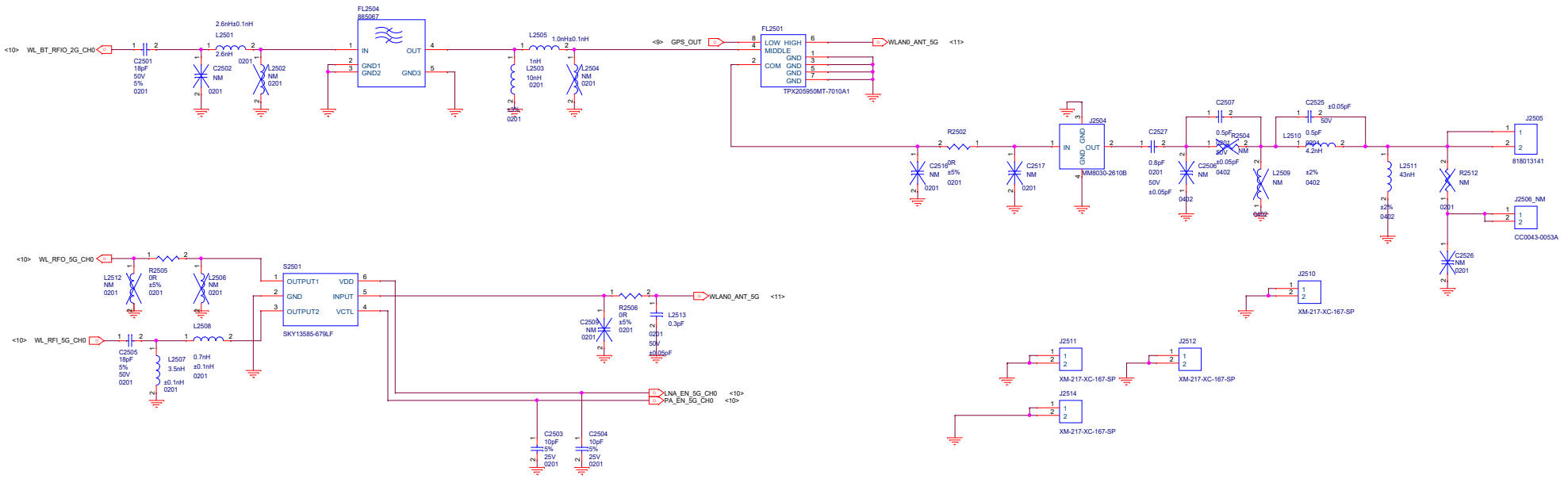

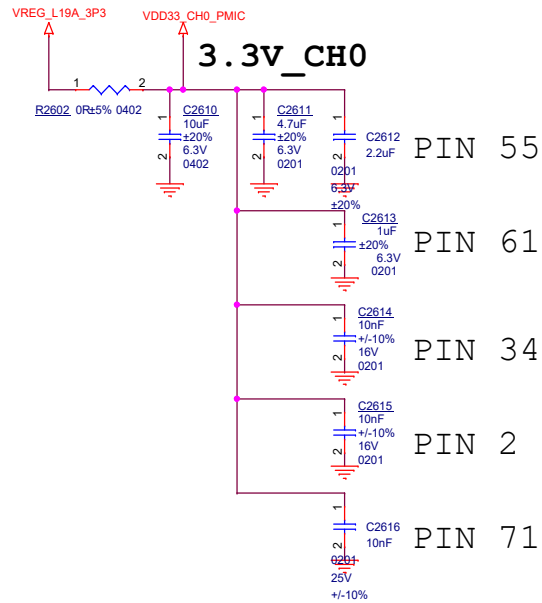
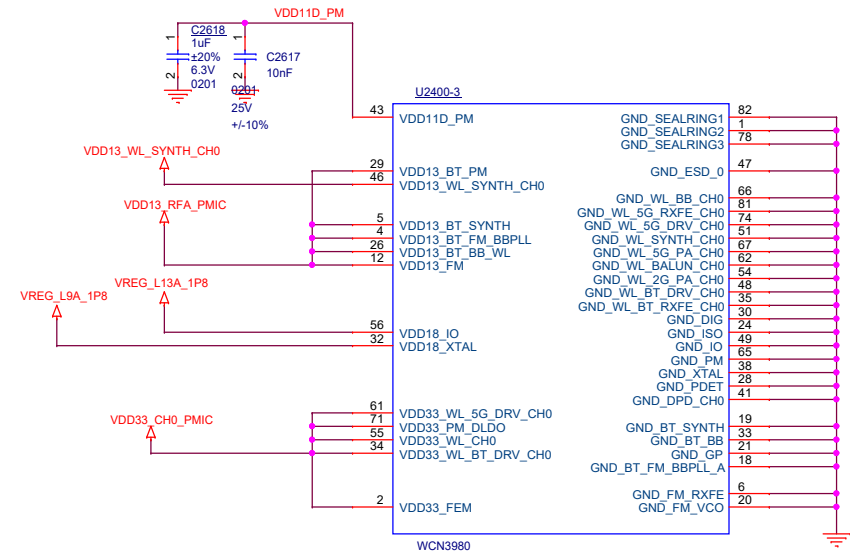
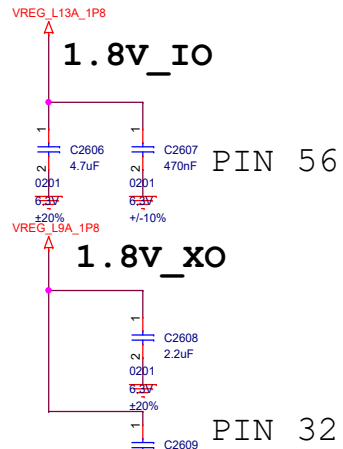
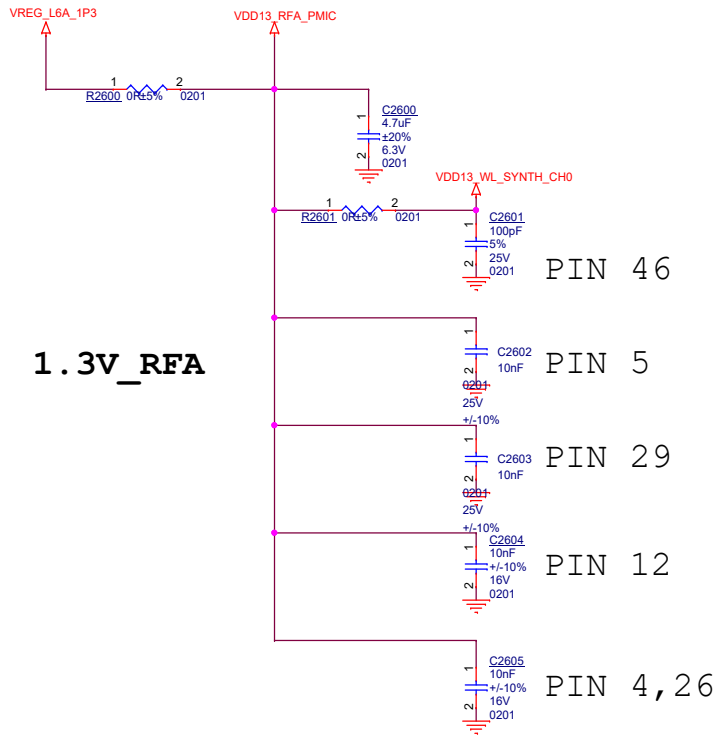

MODE Operation
 00 NATIVE
 01 TIC
 10 ATEST
 11 TEST

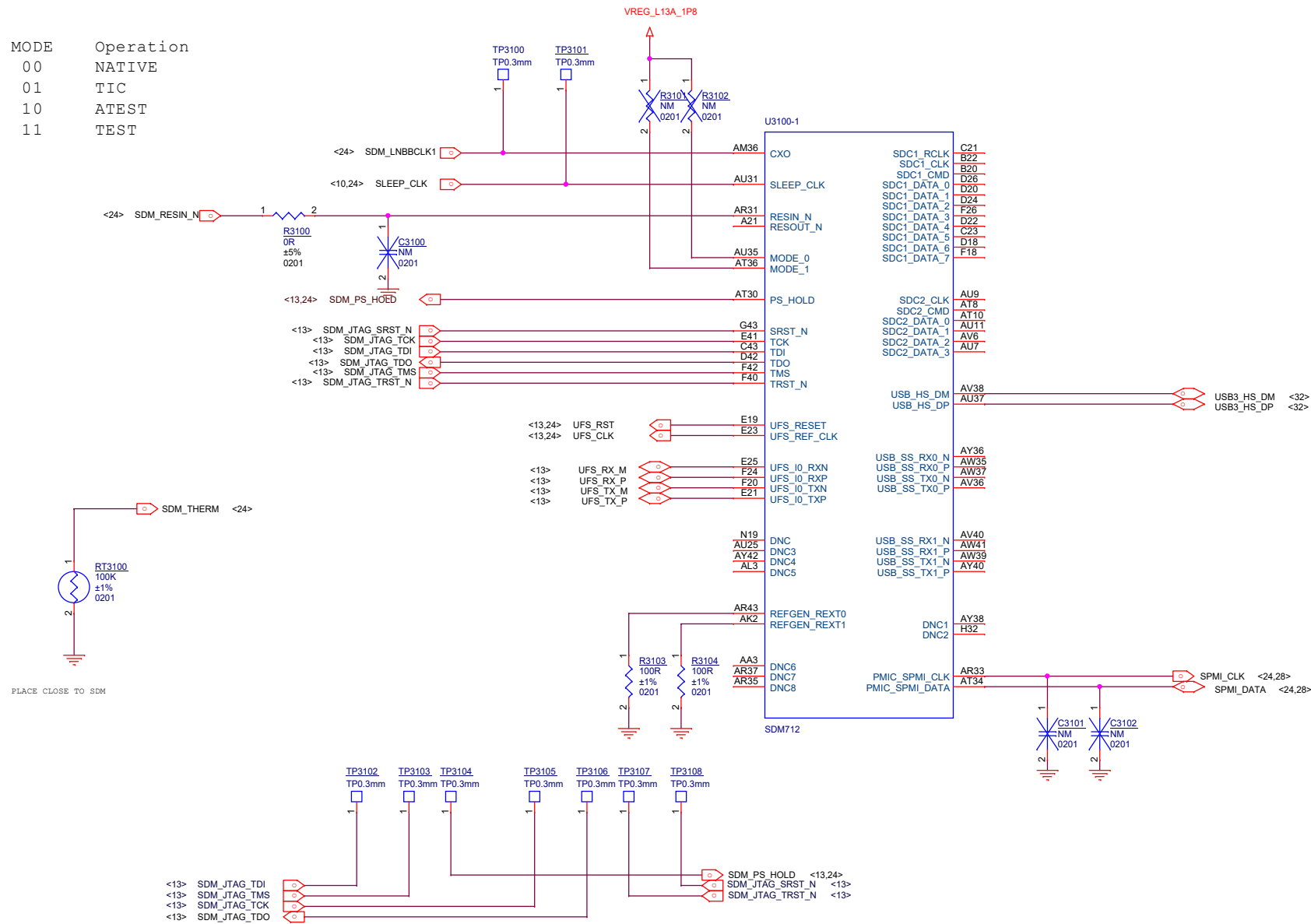

PLACE CLOSE TO SDM

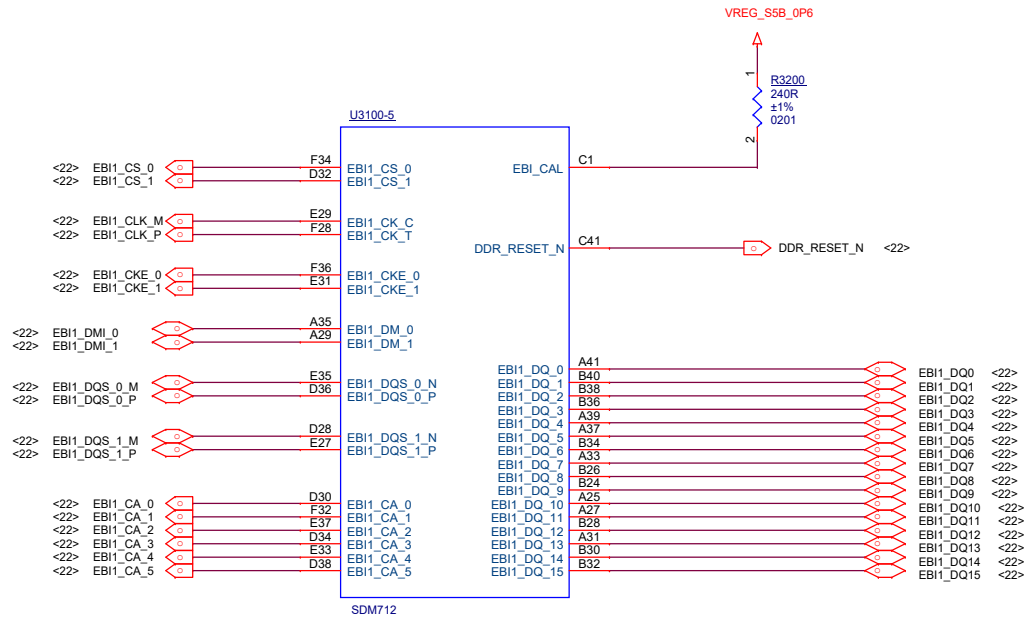
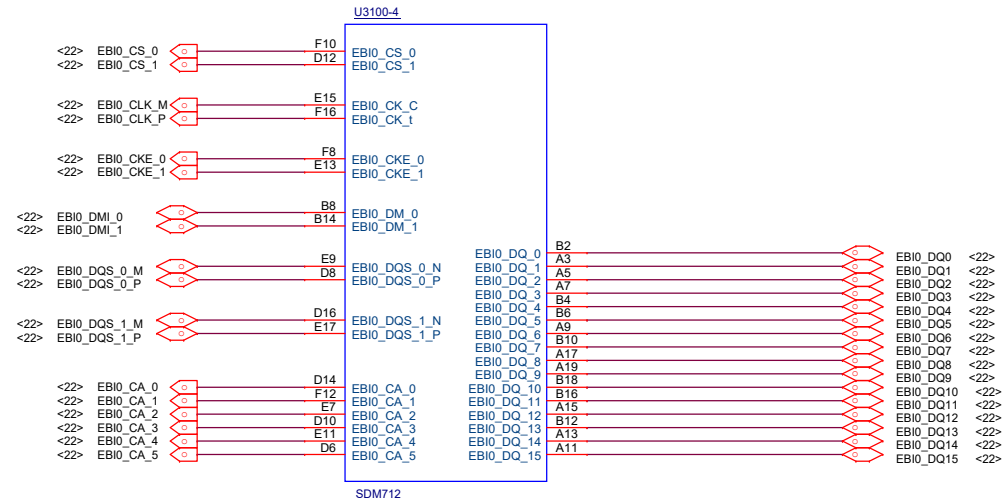

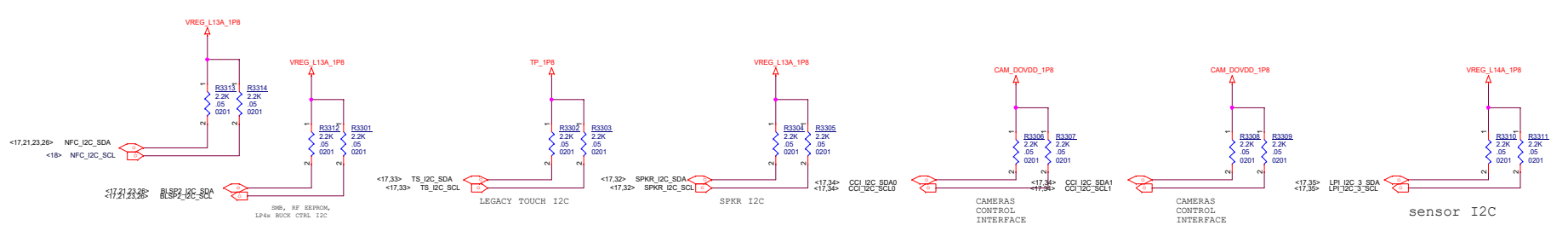
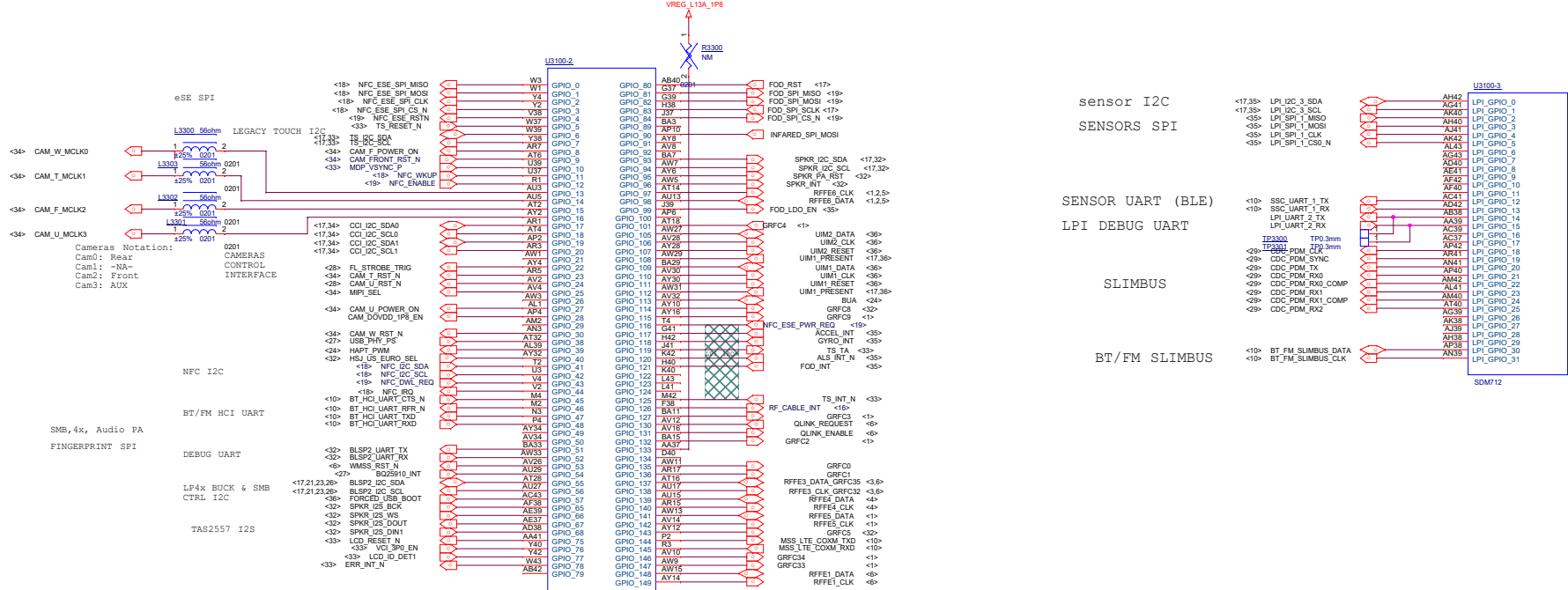

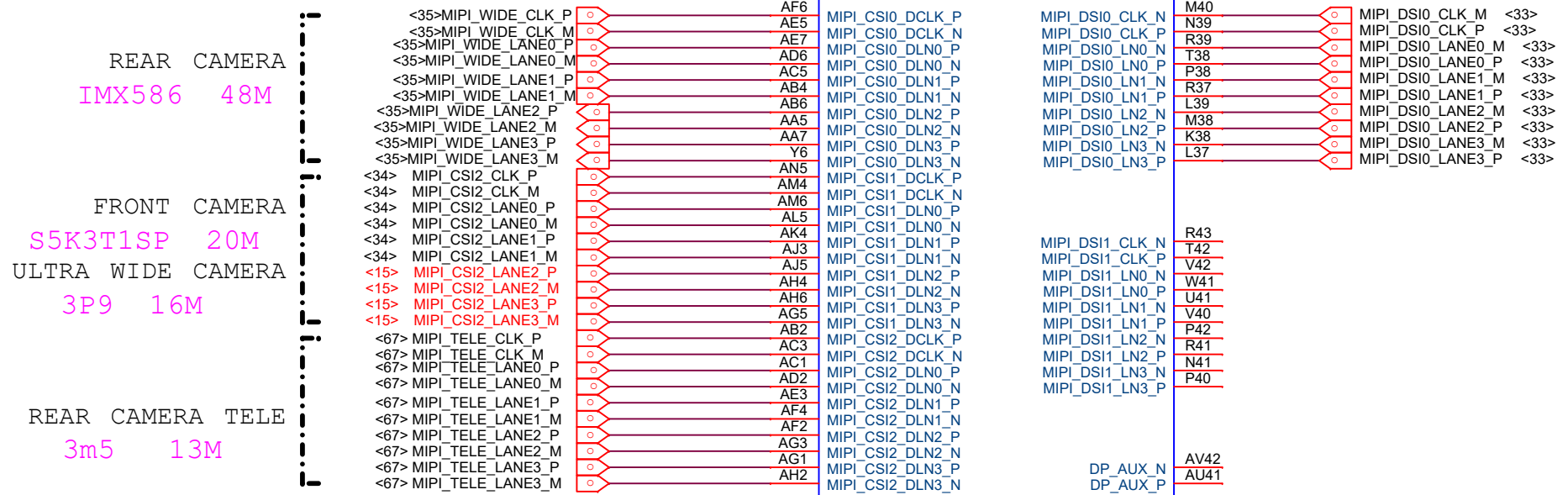

FRONT- Ultra SWITCH

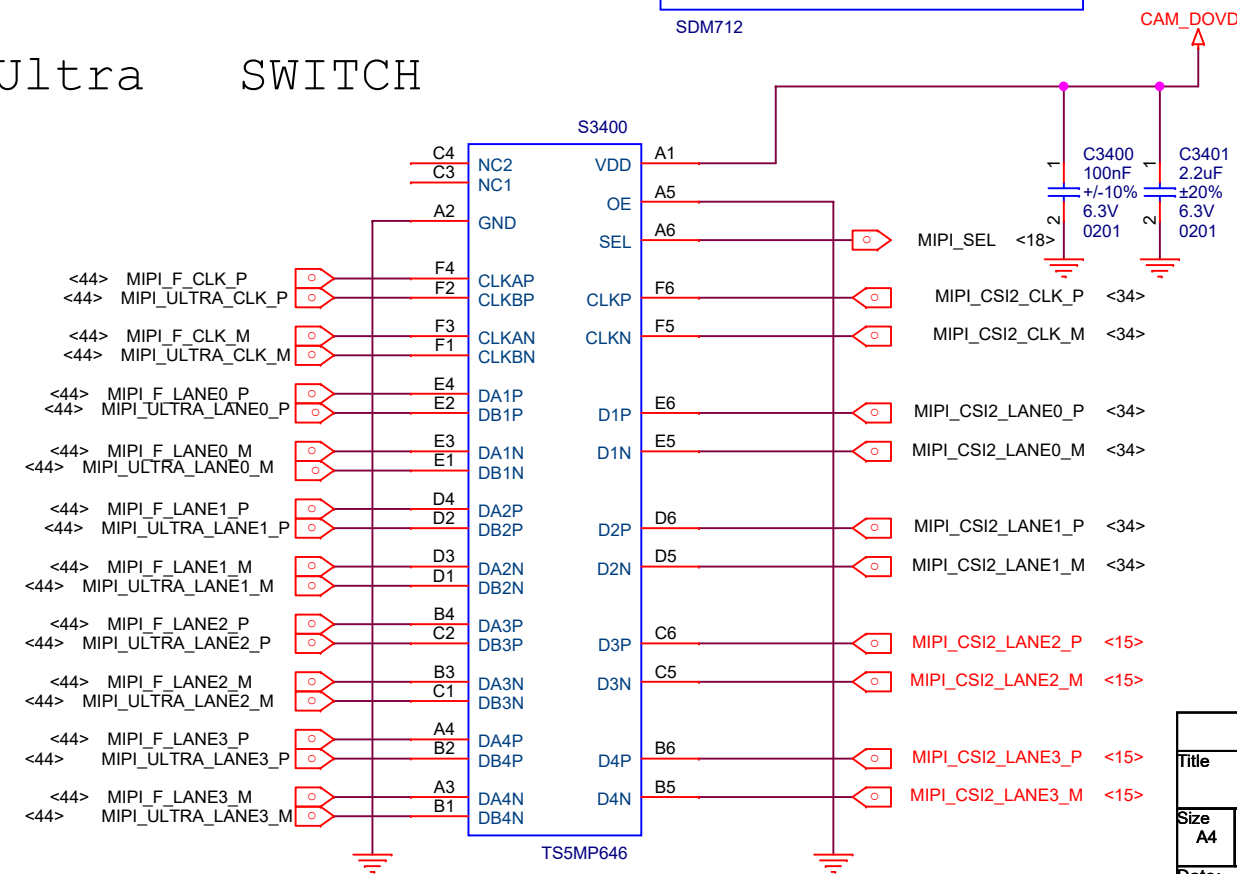

Title			F1 MAIN		
Size	Document Number				Rev
A4	SDM855 MIPI				P0
Date:	Wednesday, January 16, 2019		Sheet	35	of 71

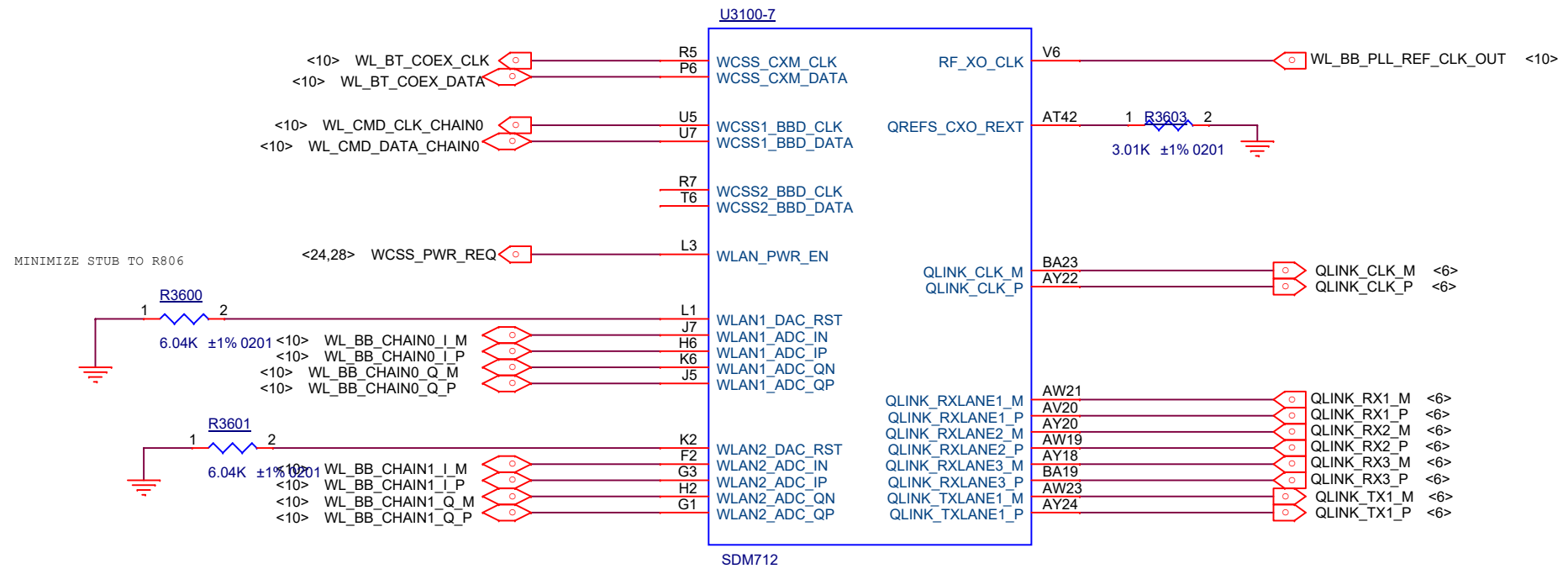

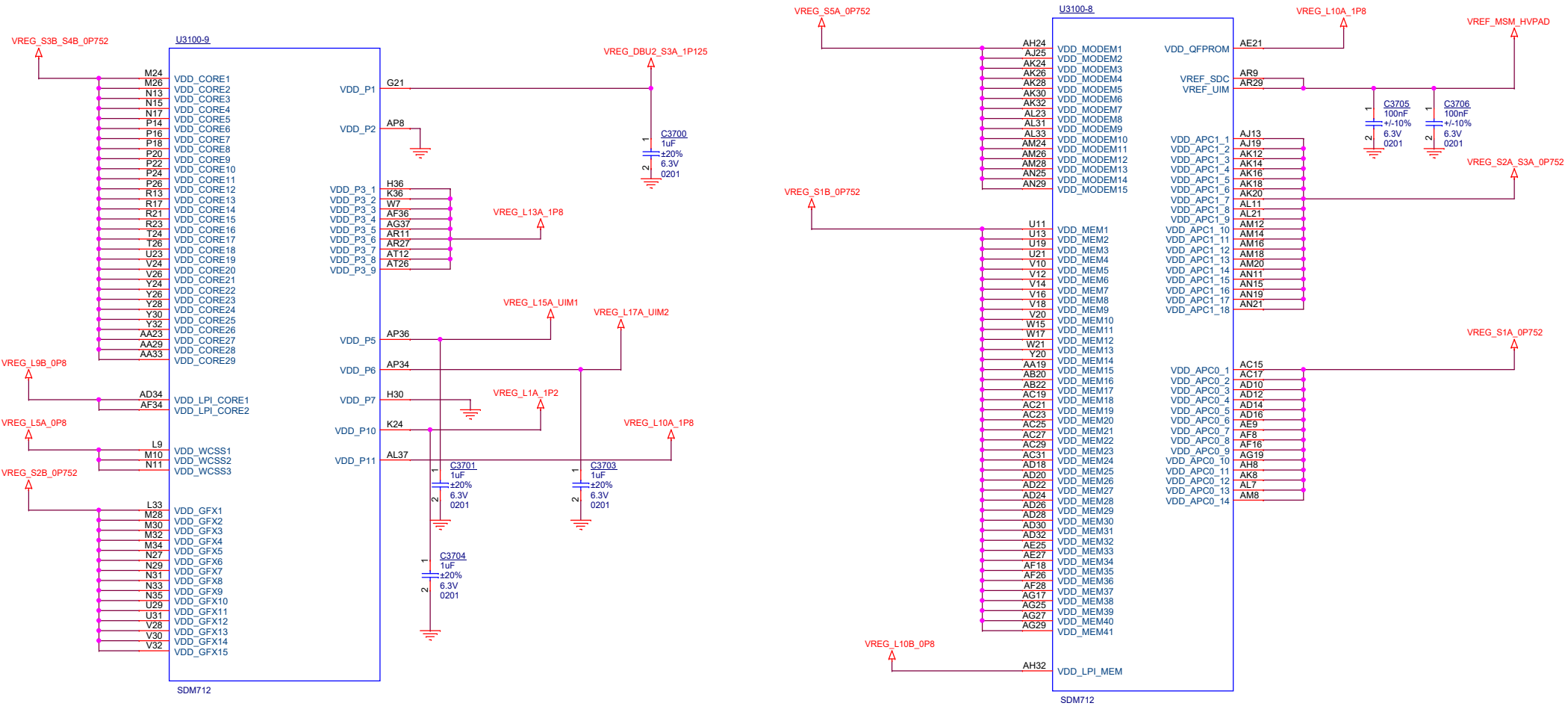

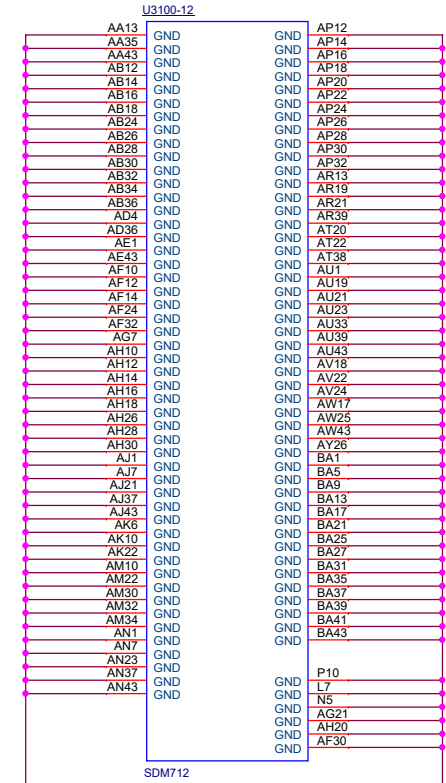
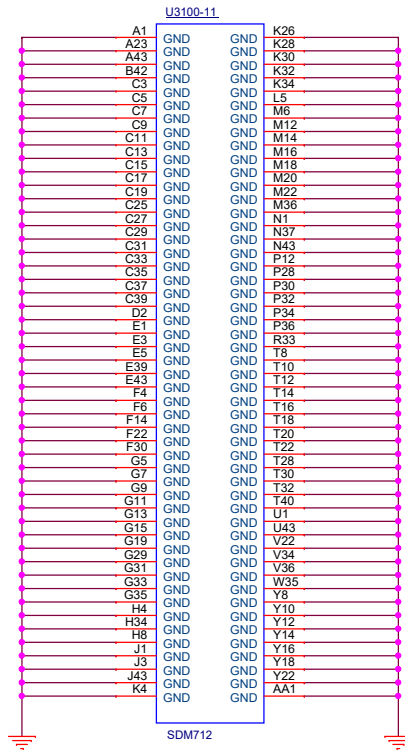

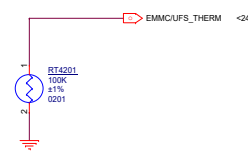
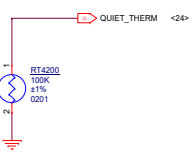
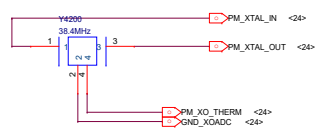
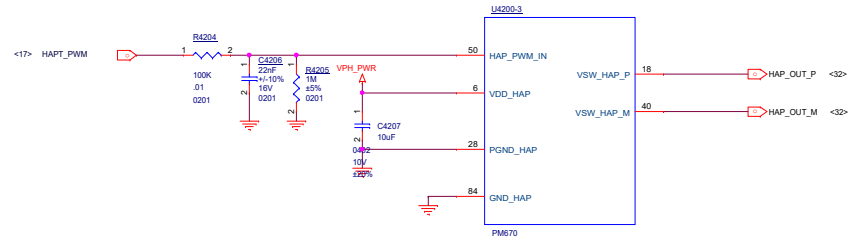
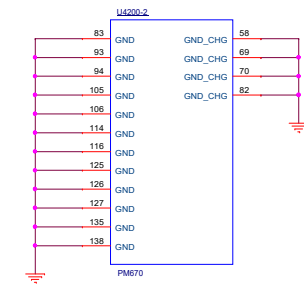
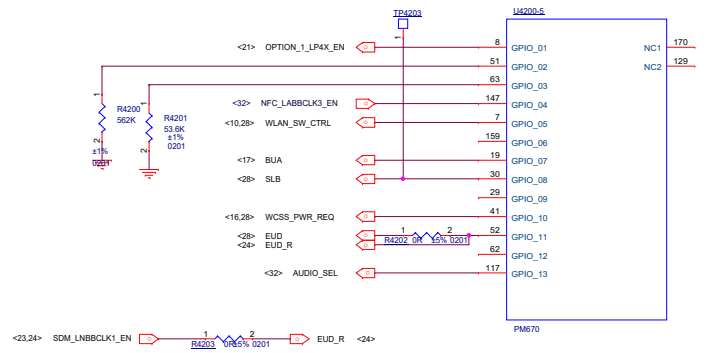
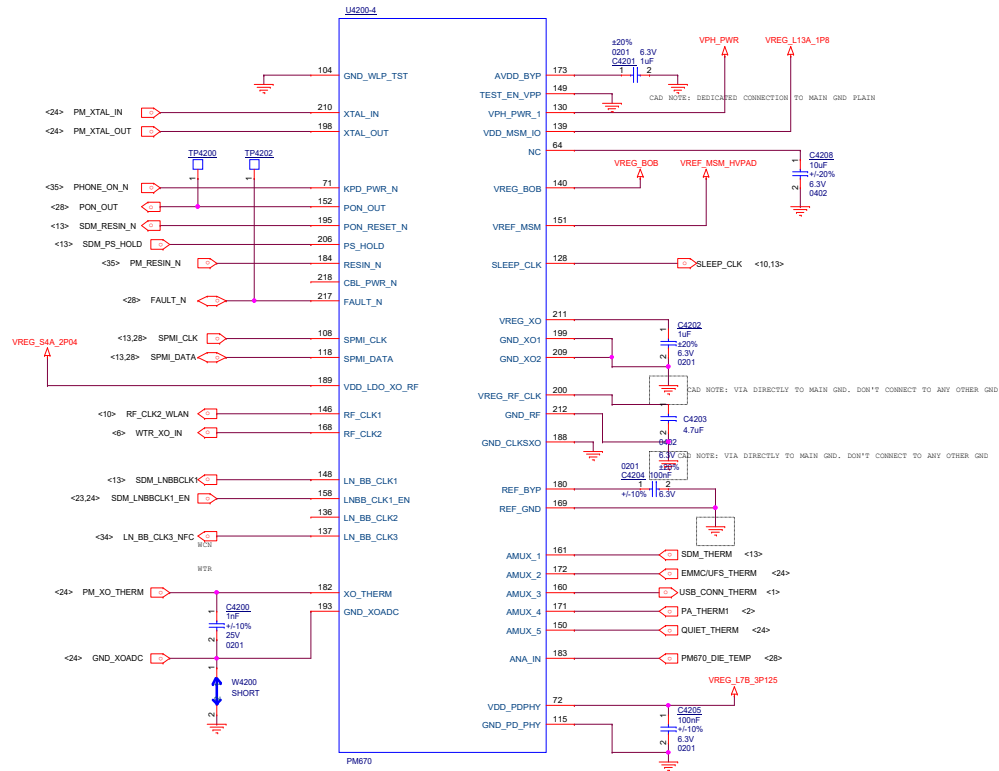

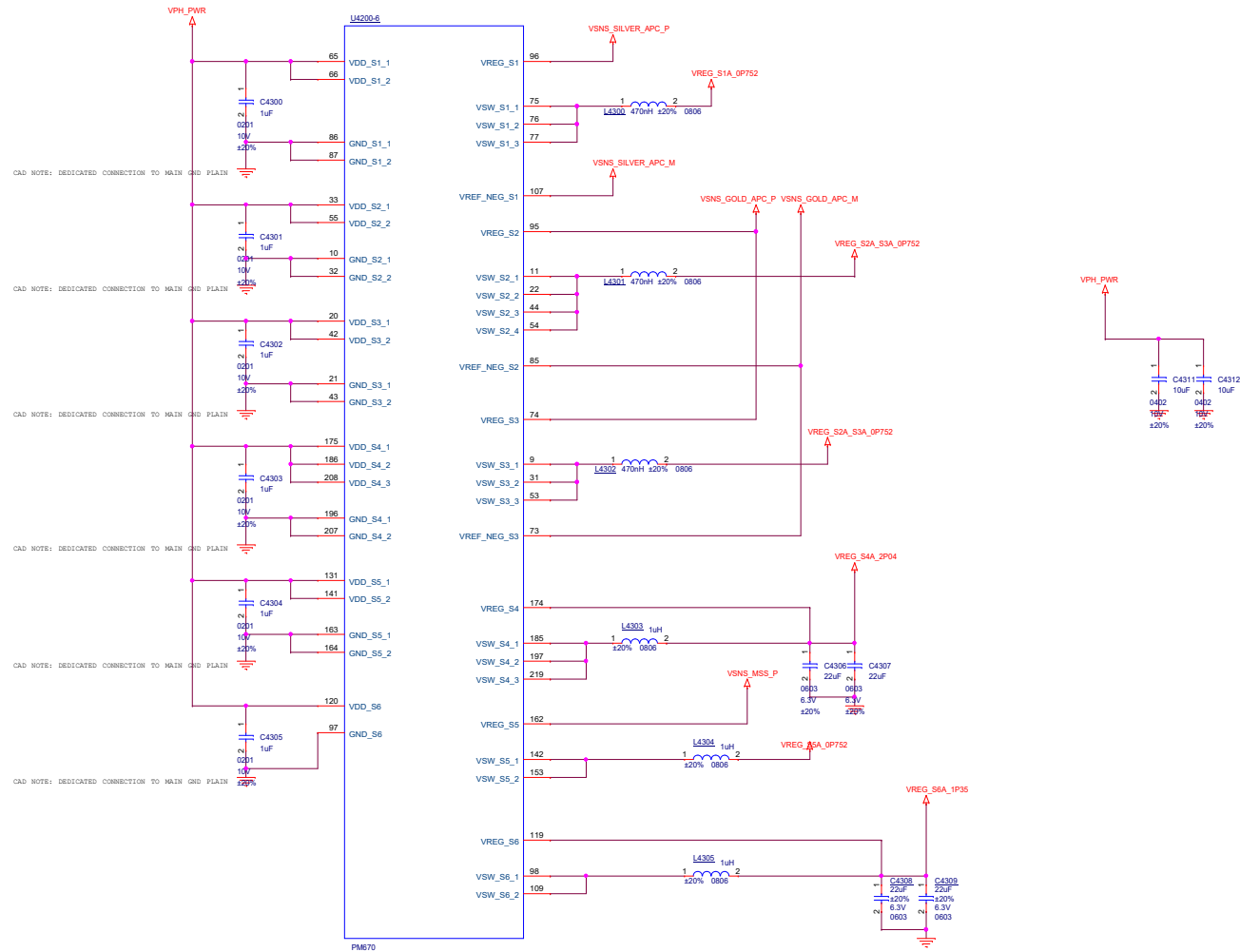

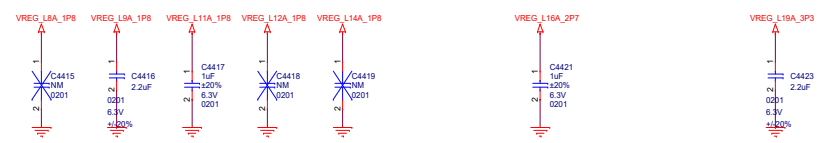
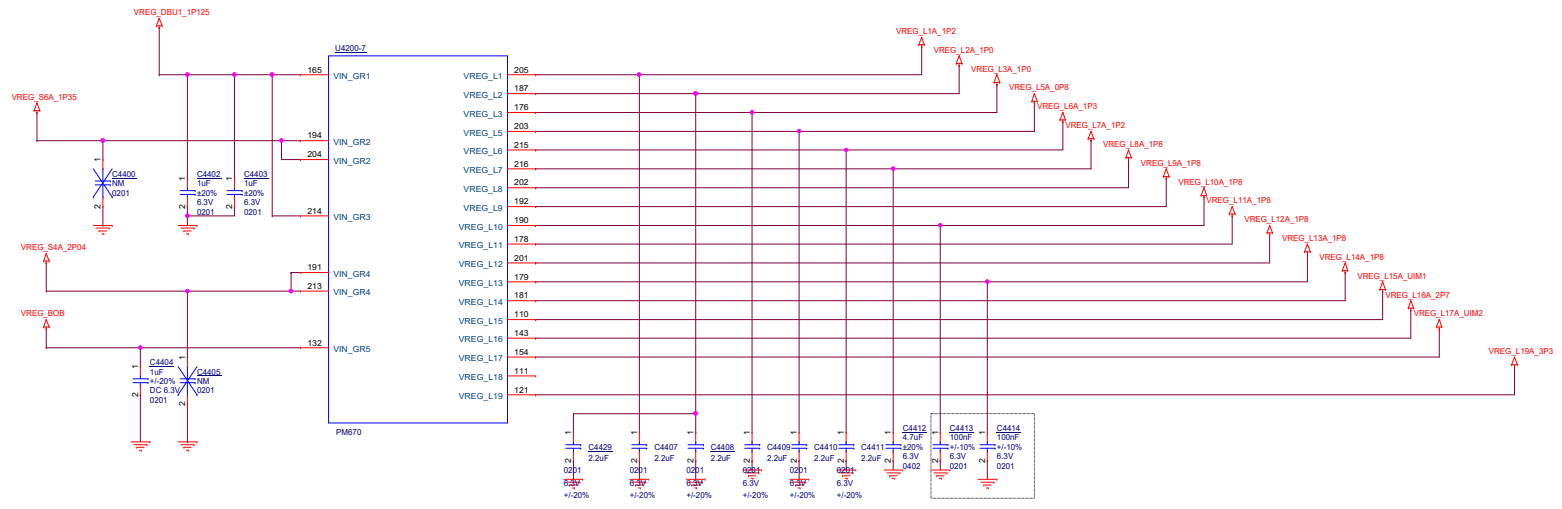

PERIOD CAPLESS LDos
For CAPLESS LDos: If decaps on the load side do not add up to LDO spec, then install the cap close to the PMIC

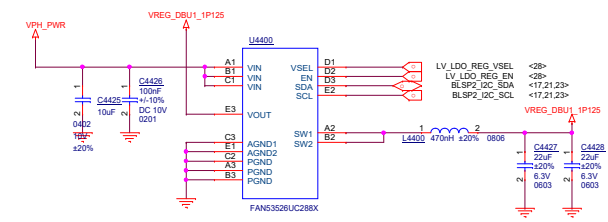

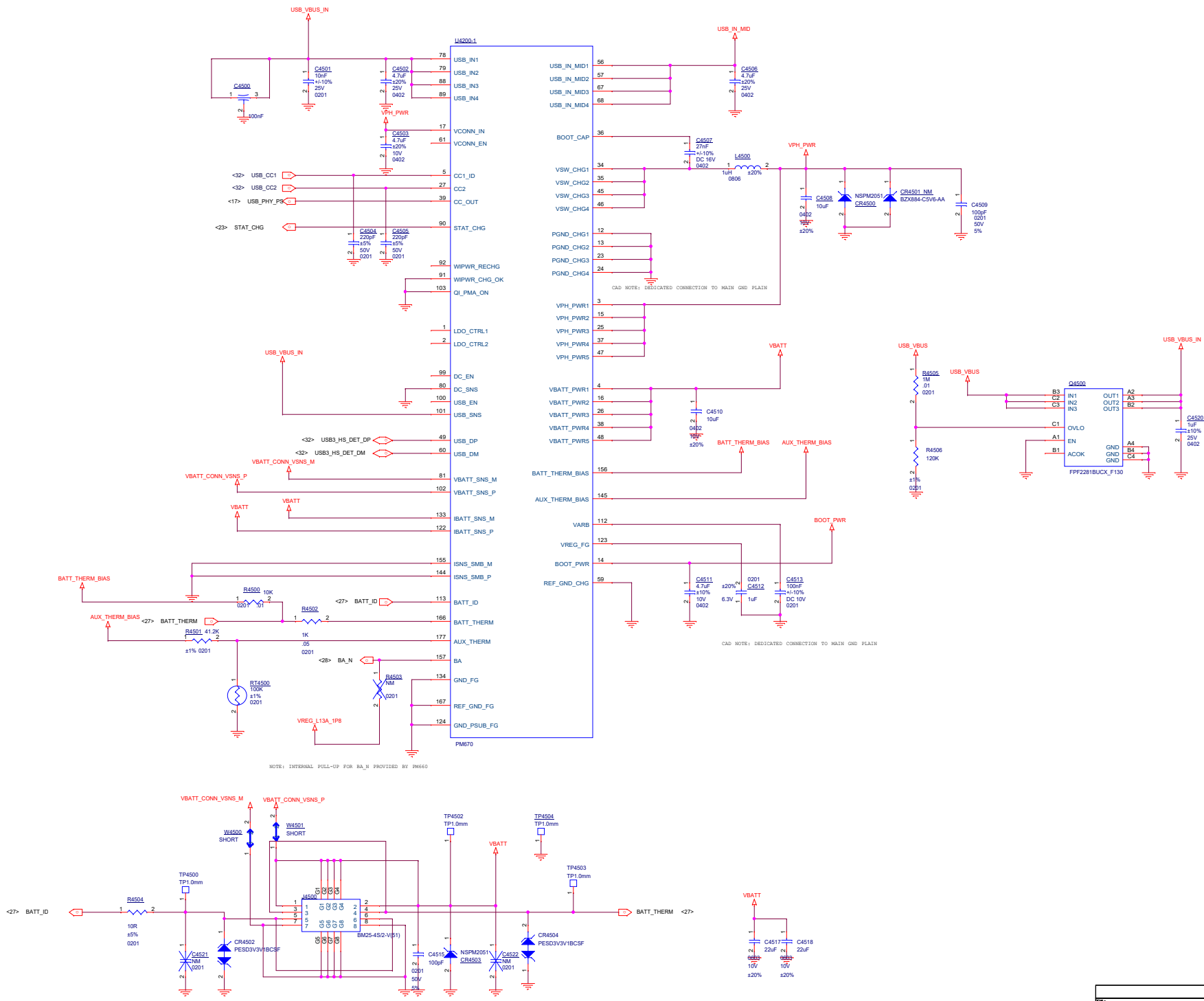

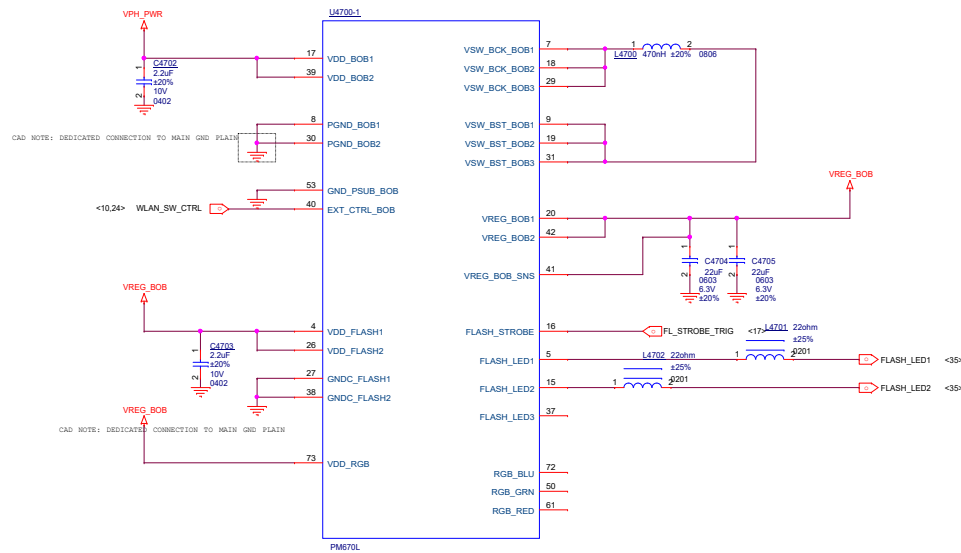
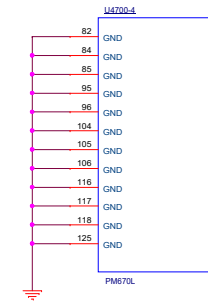
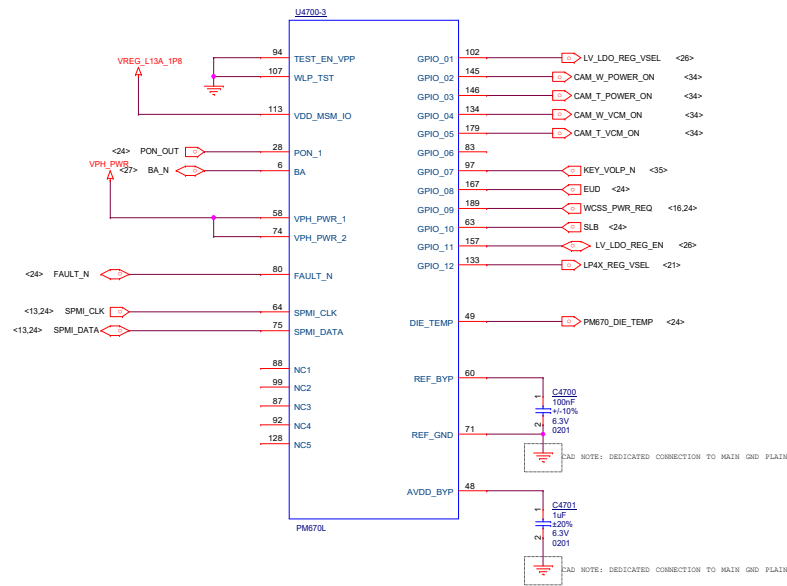

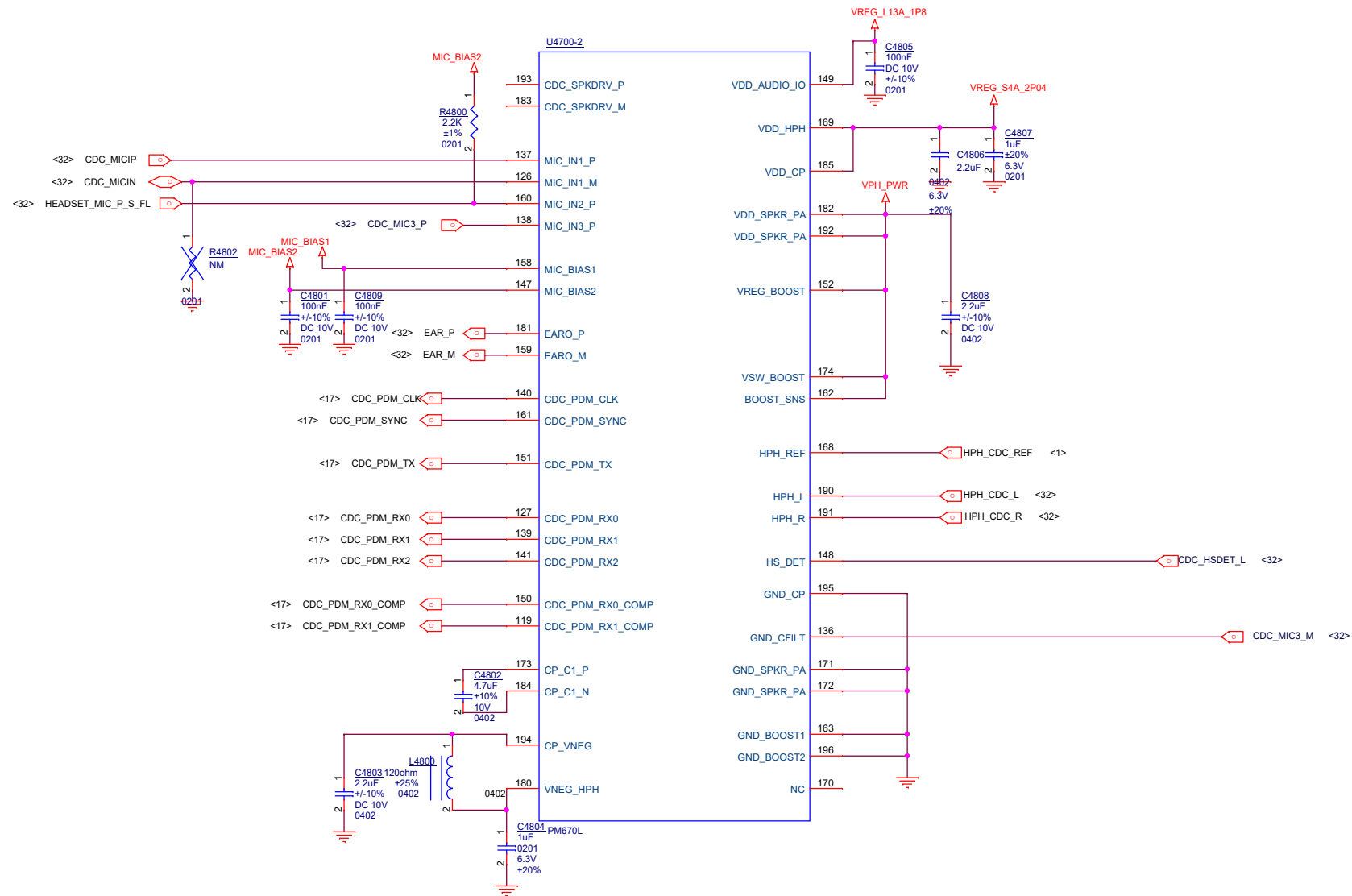

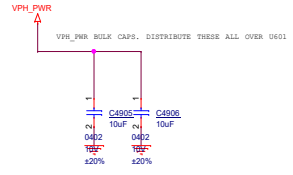
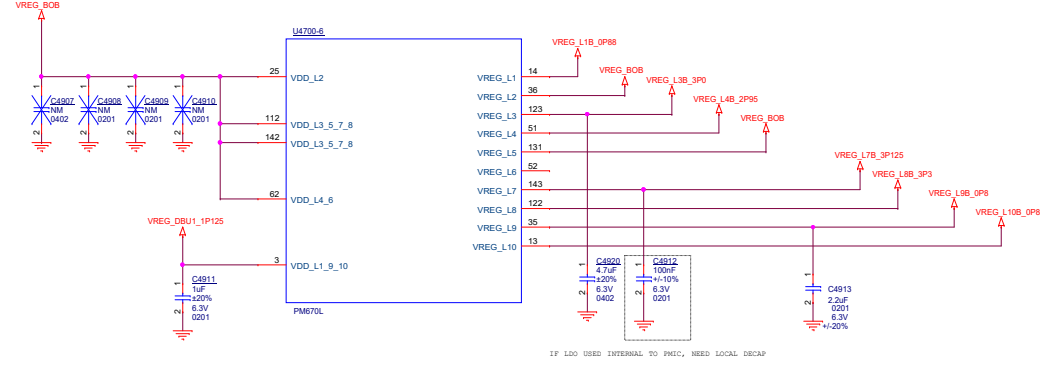
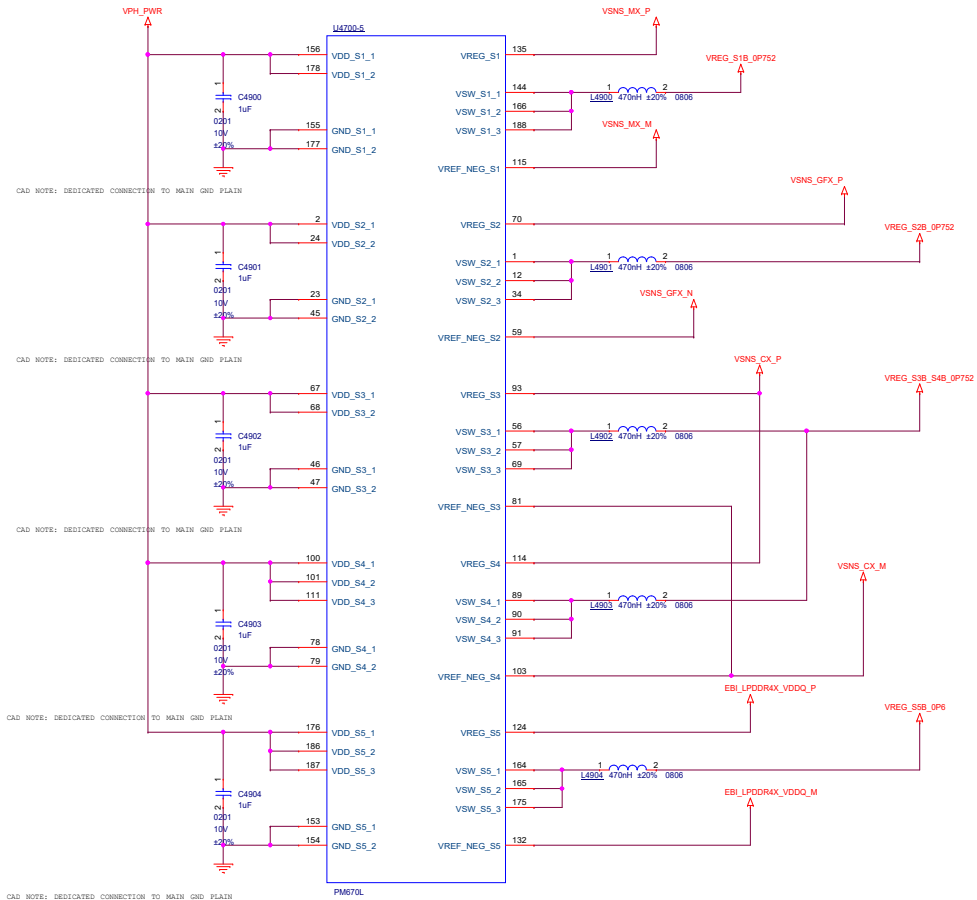

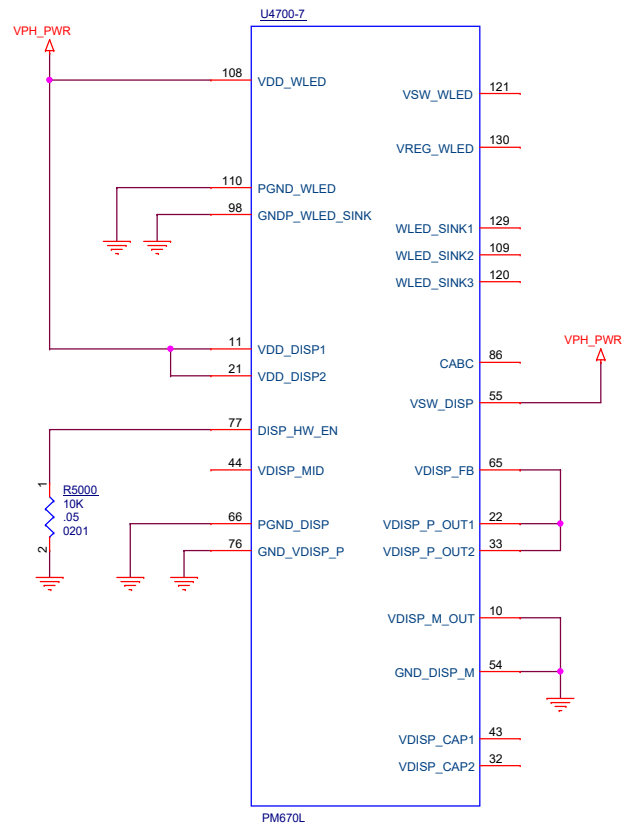

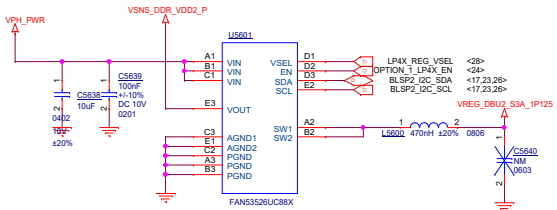
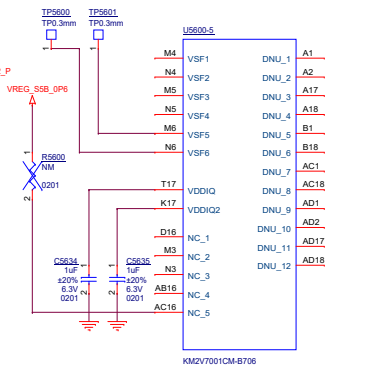
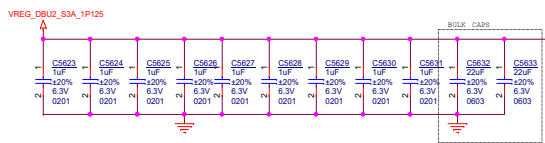
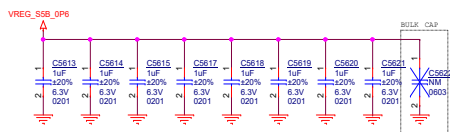
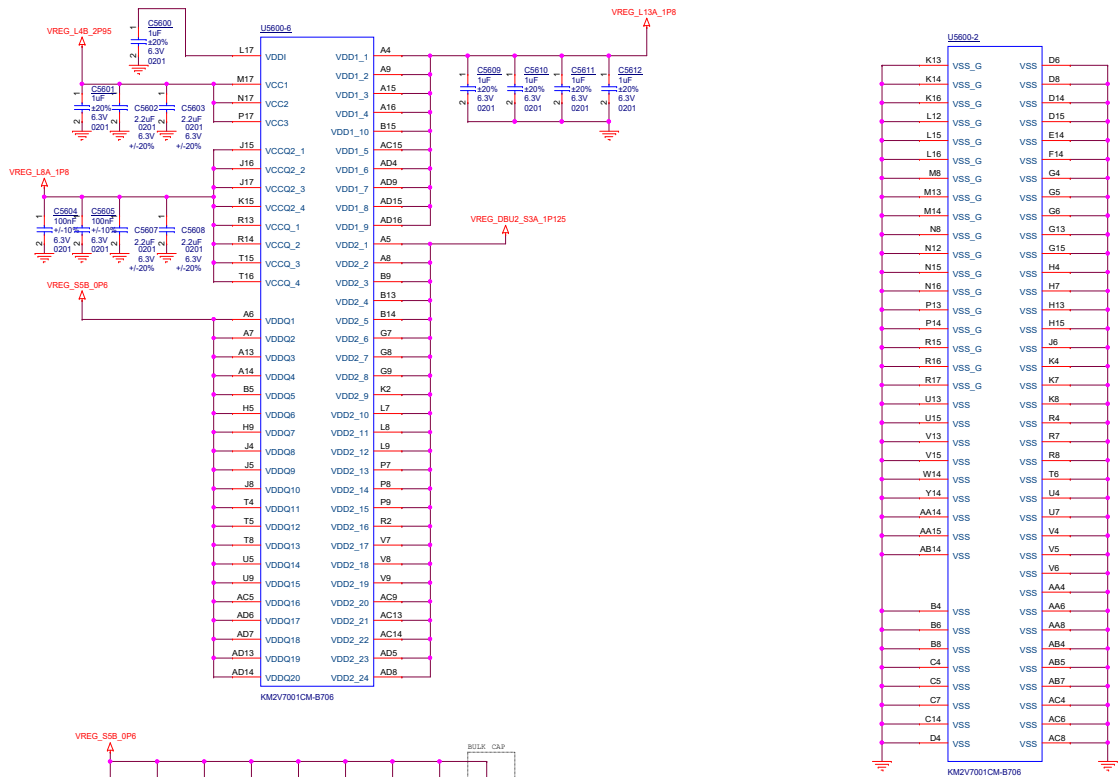

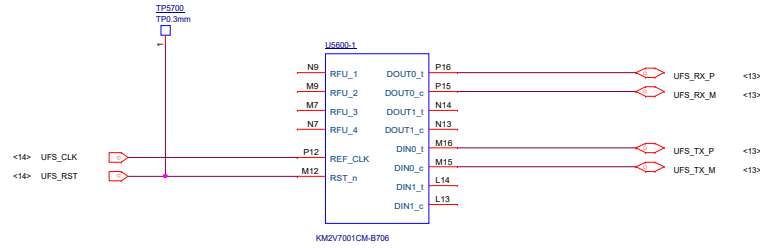

LPDDR4 / 4x

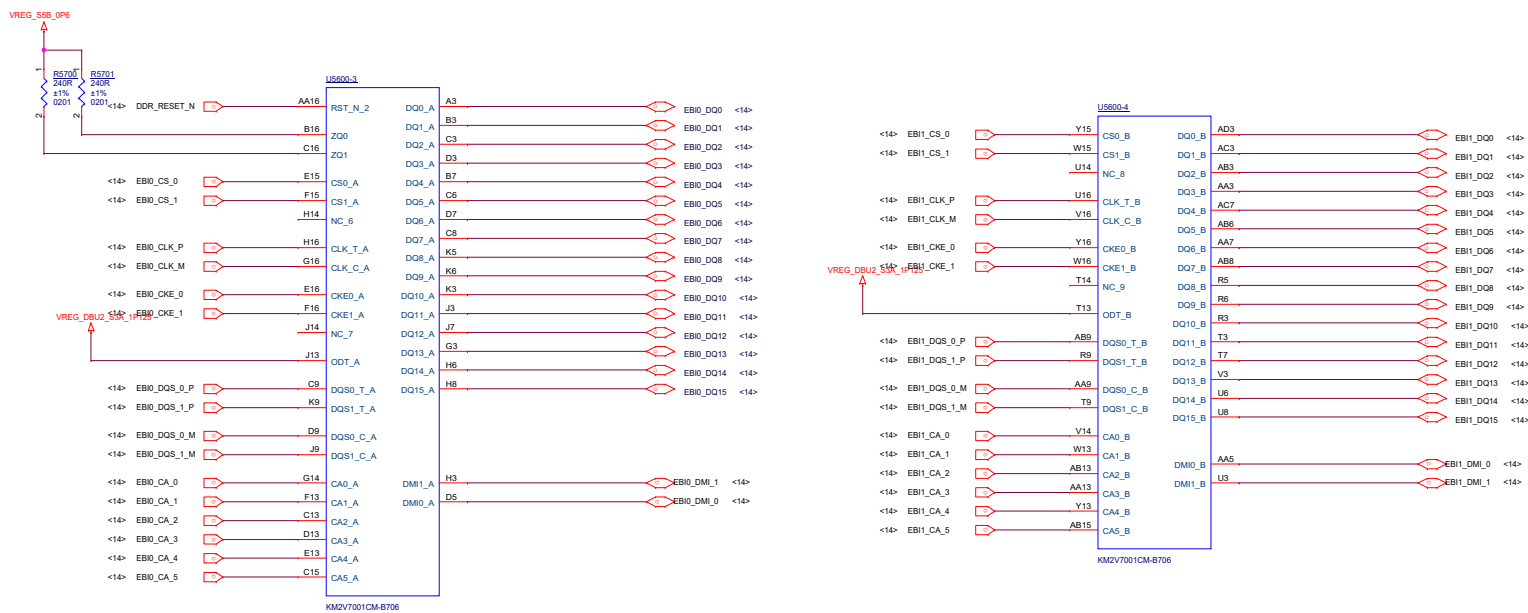

Light-sensor

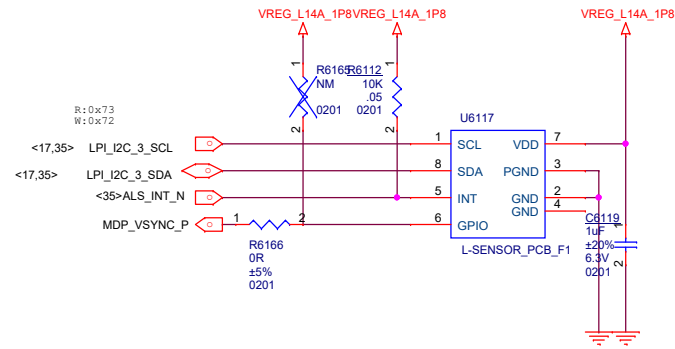

A+G

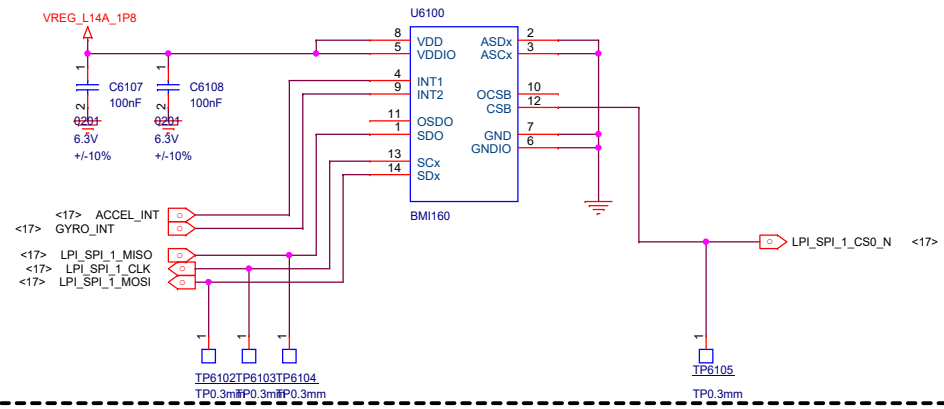

HALL

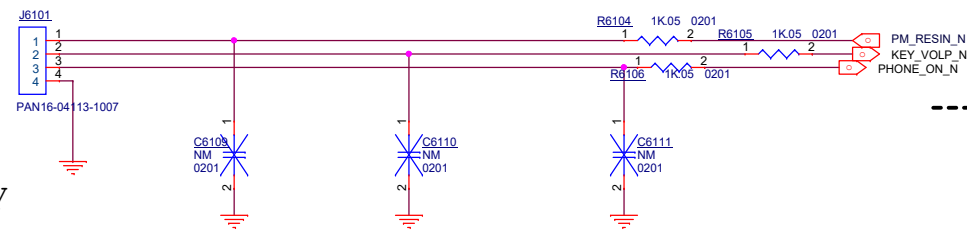

INFARED

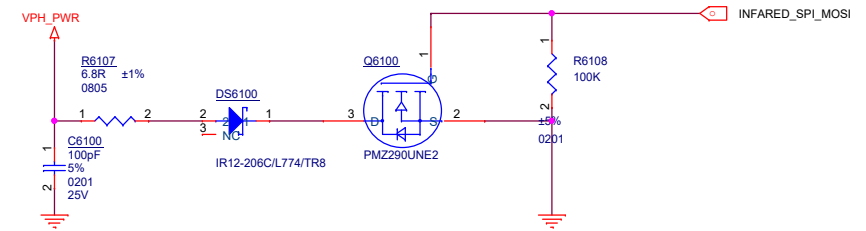

COMPASS



Title			
F1 MAIN			
Size	Document	Number	Rev
A3	SENSOR		P0
Date:	Wednesday, January 16, 2019	Sheet	62 of 71

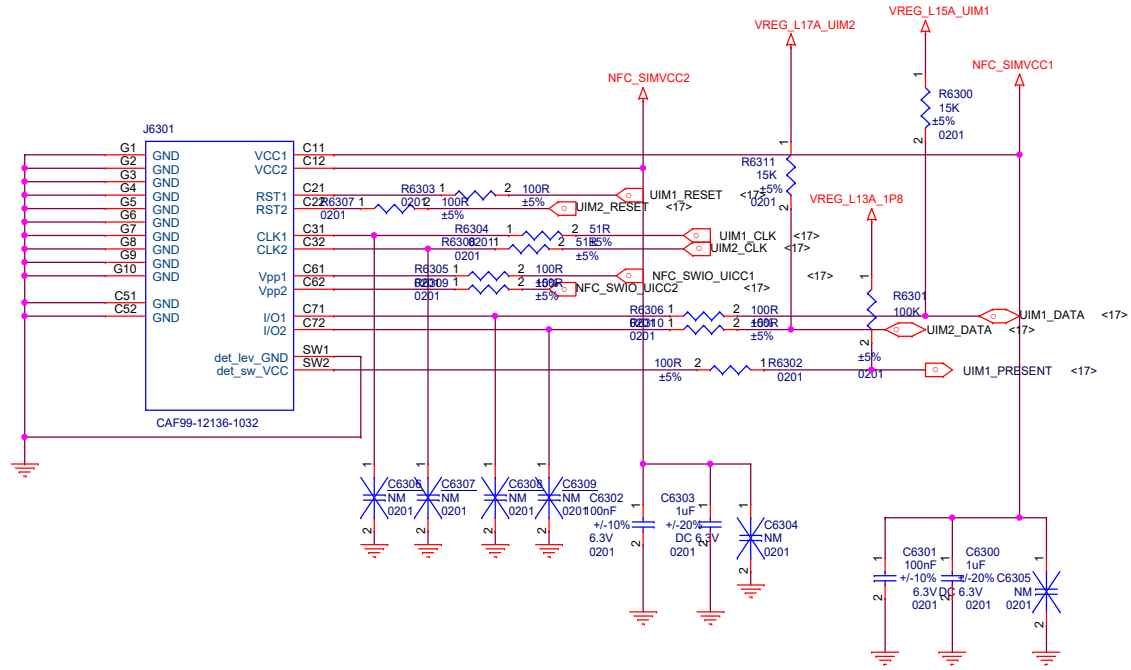

FRONT CAMERA

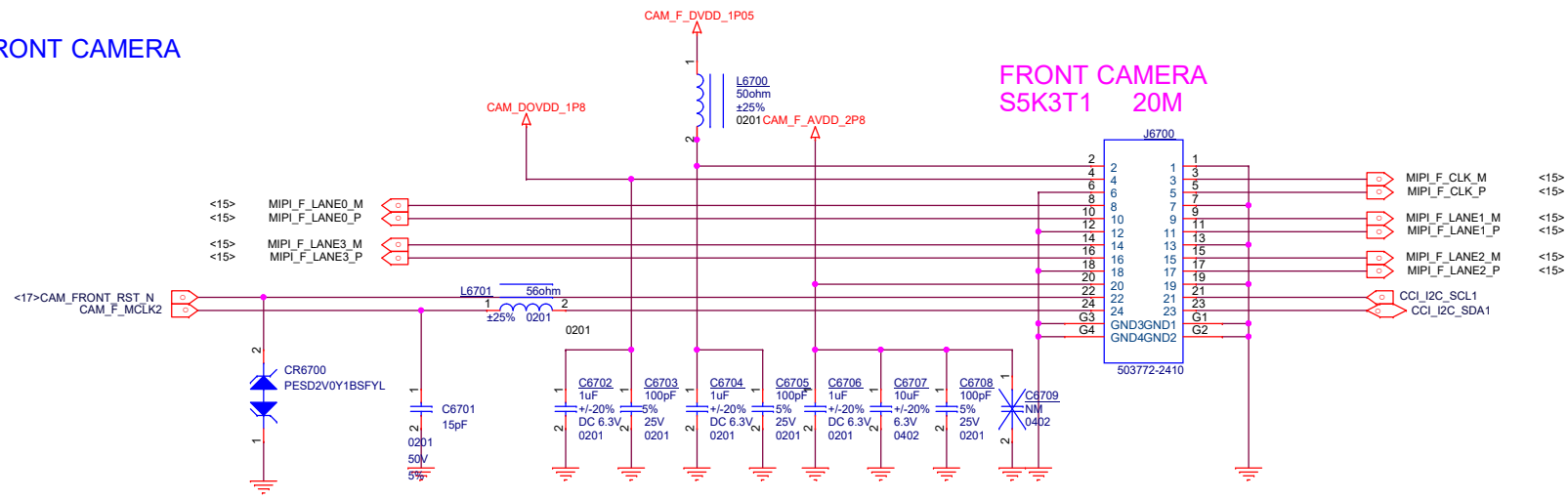

FLASH

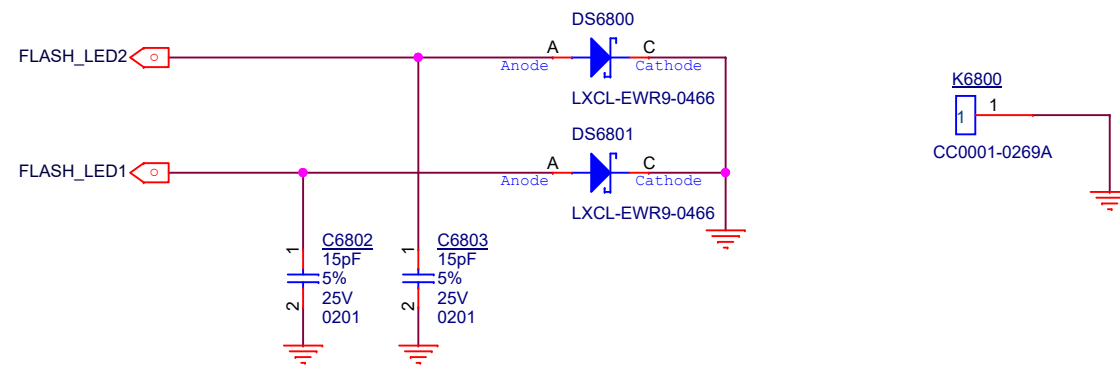

Title		
F1 MAIN		
Size	Document Number	Rev
A4	ULTRA CAMERA	P0
Date:	Wednesday, January 16, 2019	Sheet 69 of 71

