

Ant Con&Coupler & Switchplexer

Title			A1
Size	Document Number	<Doc>	
A3	<Doc>		
Date:	Friday, August 05, 2016	Sheet	1 of 37
		Rev	P0

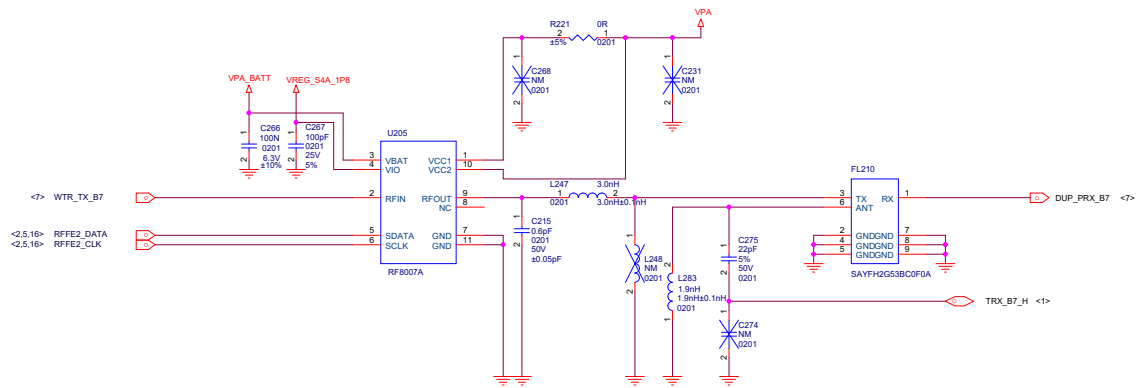

BAND7

File		A1	
Size	A2	Document Number	<Doc>
Date:	Friday, August 05, 2016	Sheet	3 of 37

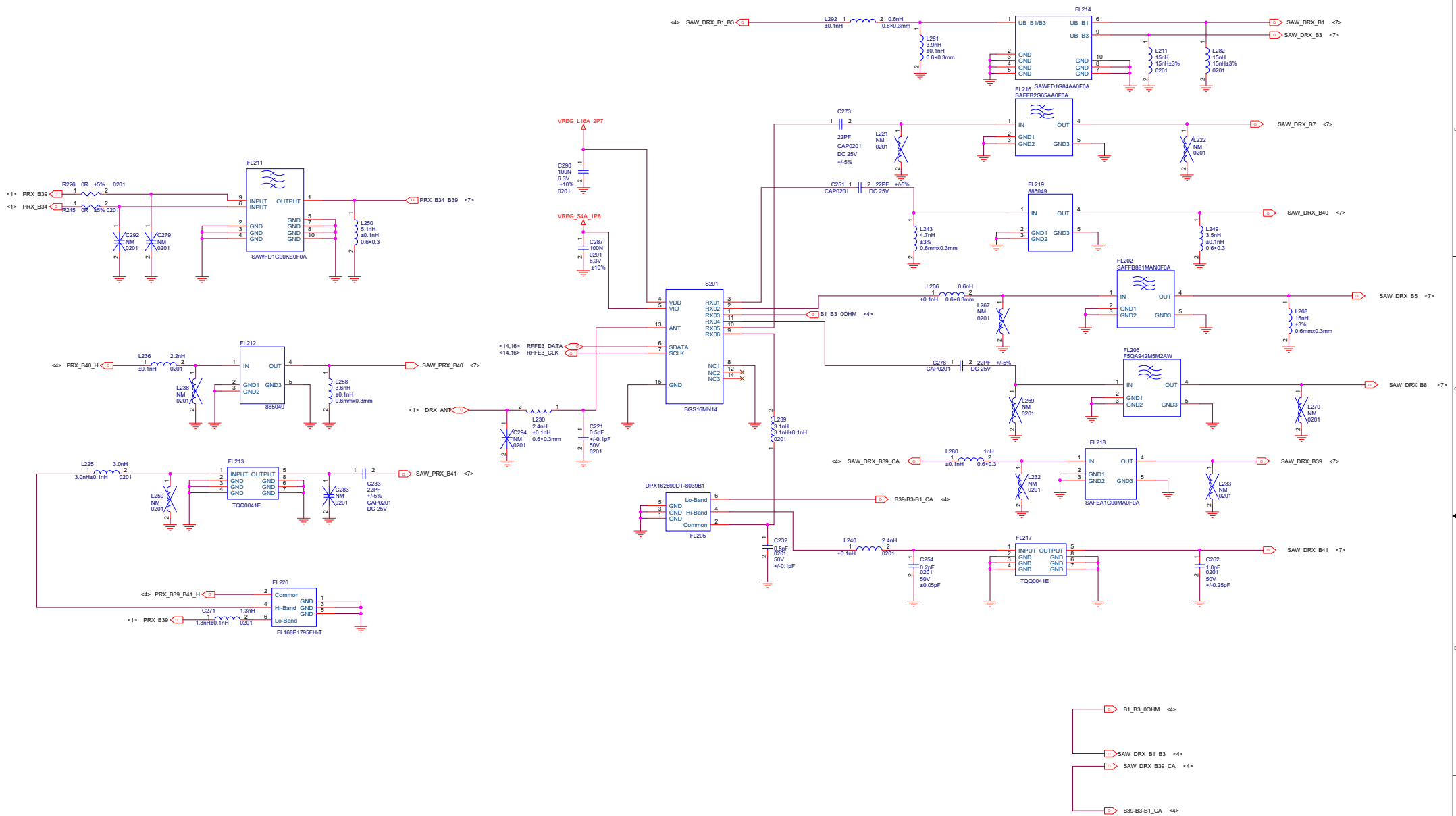

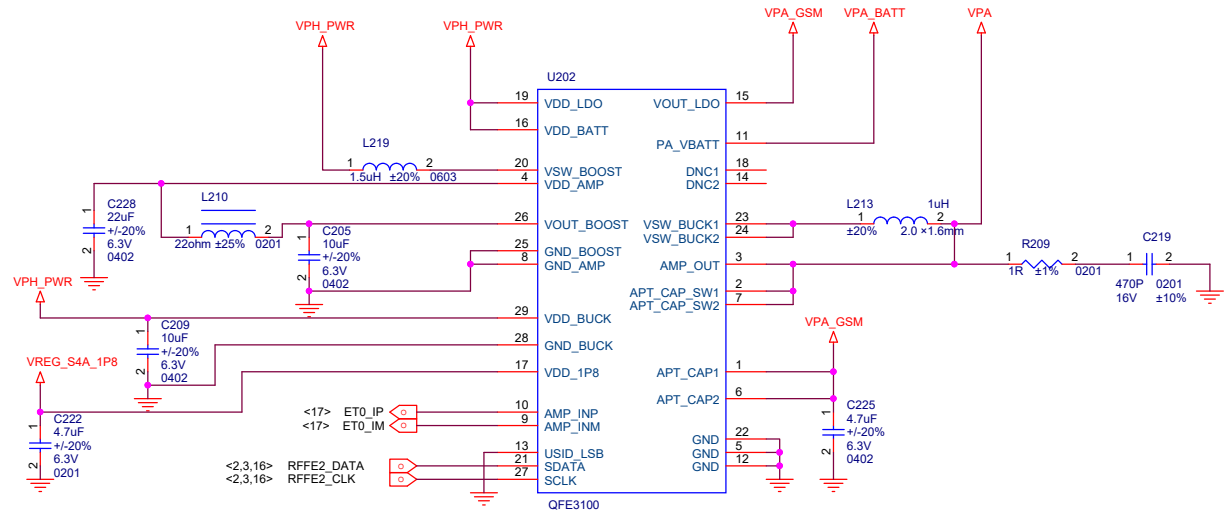

QFE3100

Title		
A1		
Size	Document Number	Rev
A3	<Doc>	P0
Date:	Friday, August 05, 2016	Sheet 5 of 37

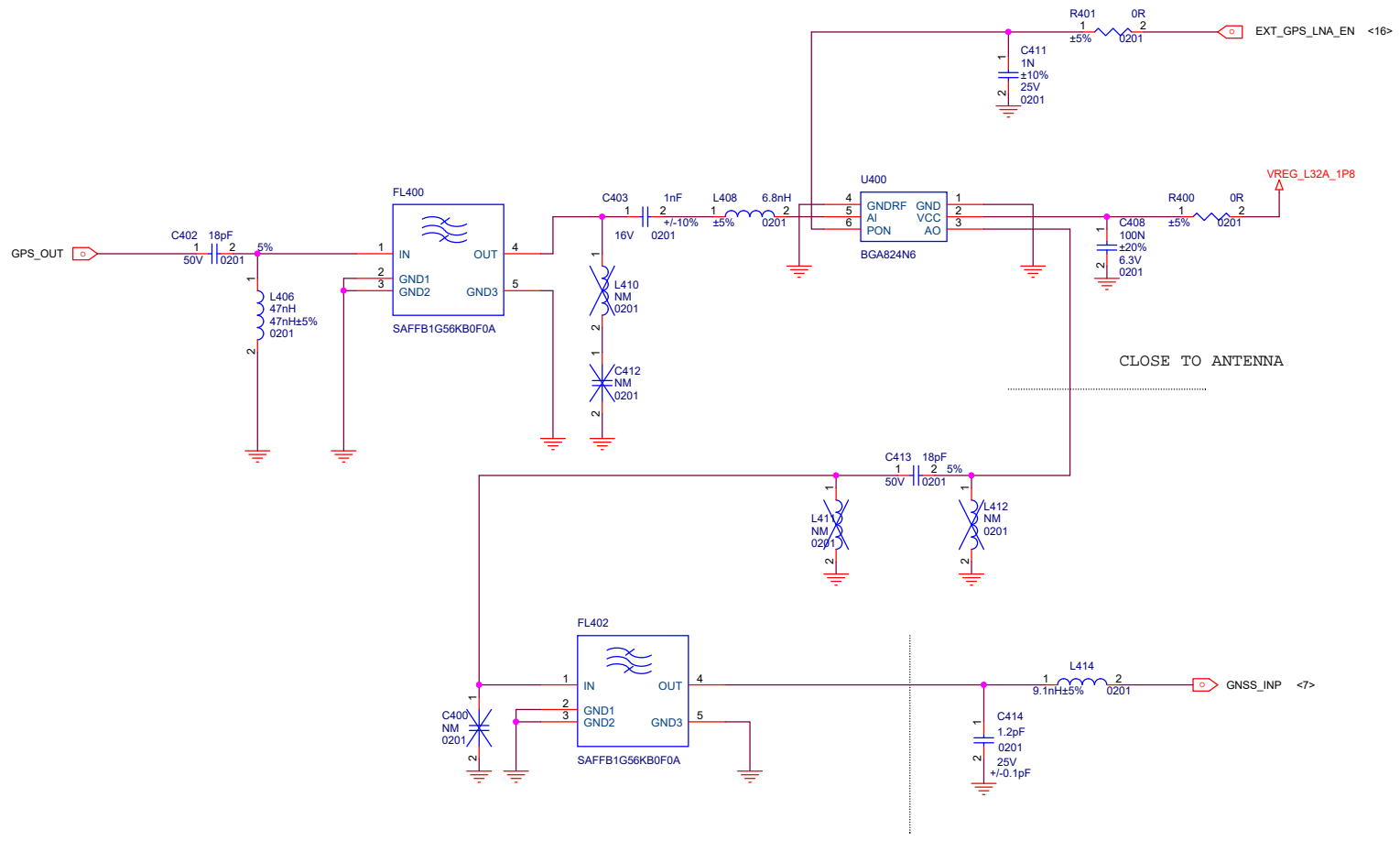

GPS

Title		
A1		
Size	Document Number	Rev
A3	<Doc>	P0
Date:	Friday, August 05, 2016	Sheet 6 of 37

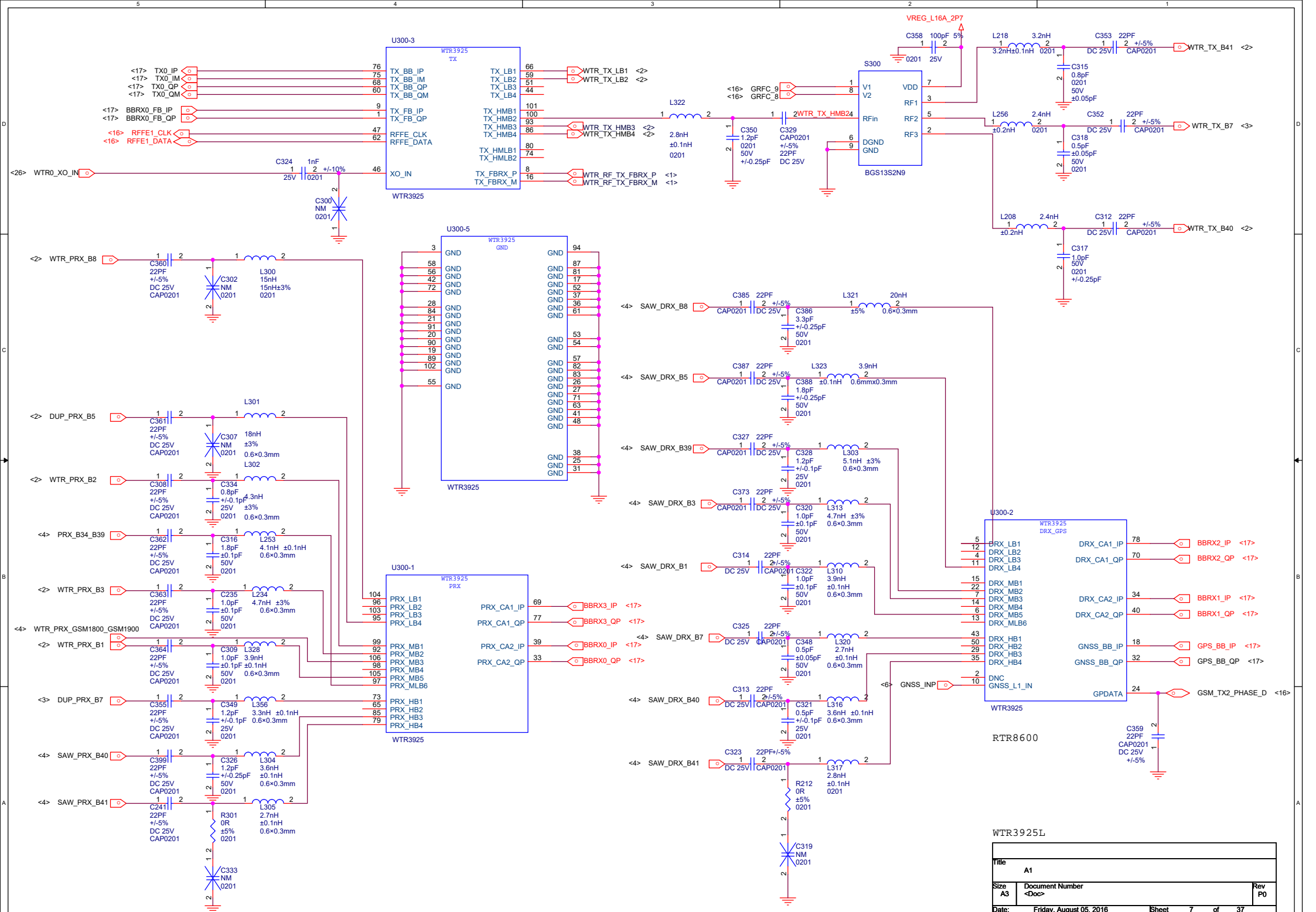

Title		
A1		
Size	Document Number	Rev
A3	<Doc>	P0
Date:	Friday, August 05, 2016	Sheet 7 of 37

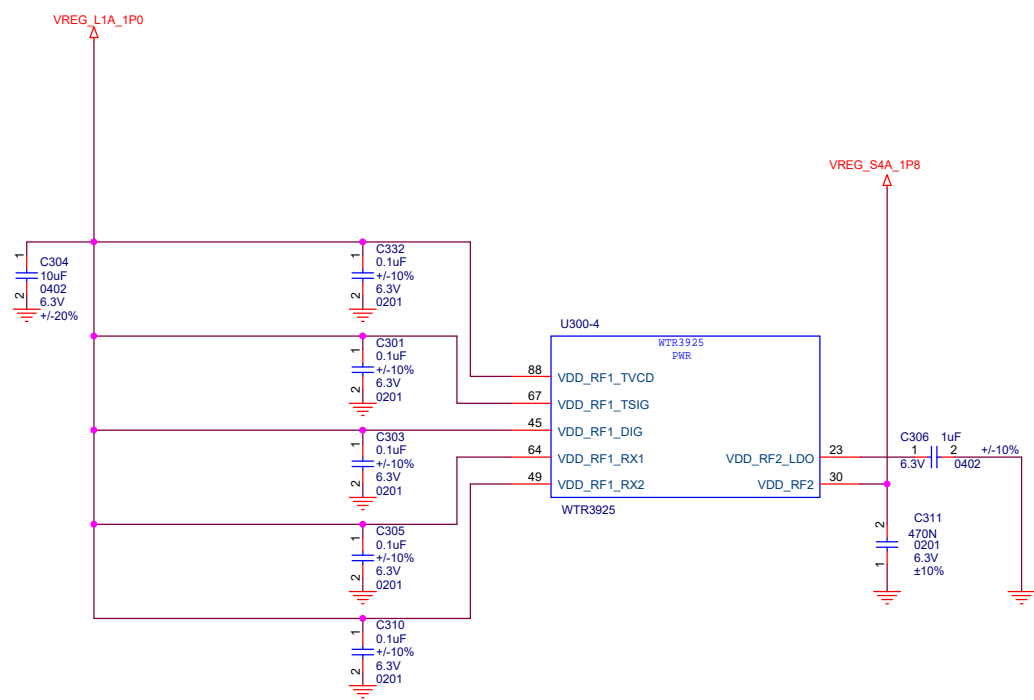

WTR3925L BYPASS

Title		
A1		
Size	Document Number	Rev
A3	<Doc>	P0
Date:	Friday, August 05, 2016	Sheet 8 of 37

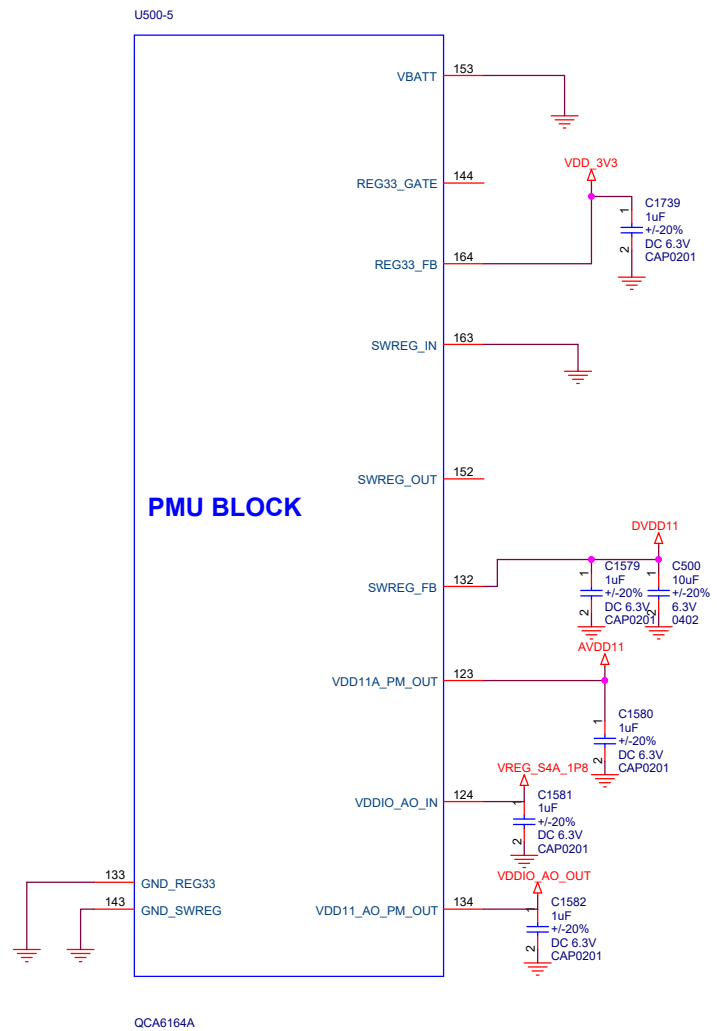
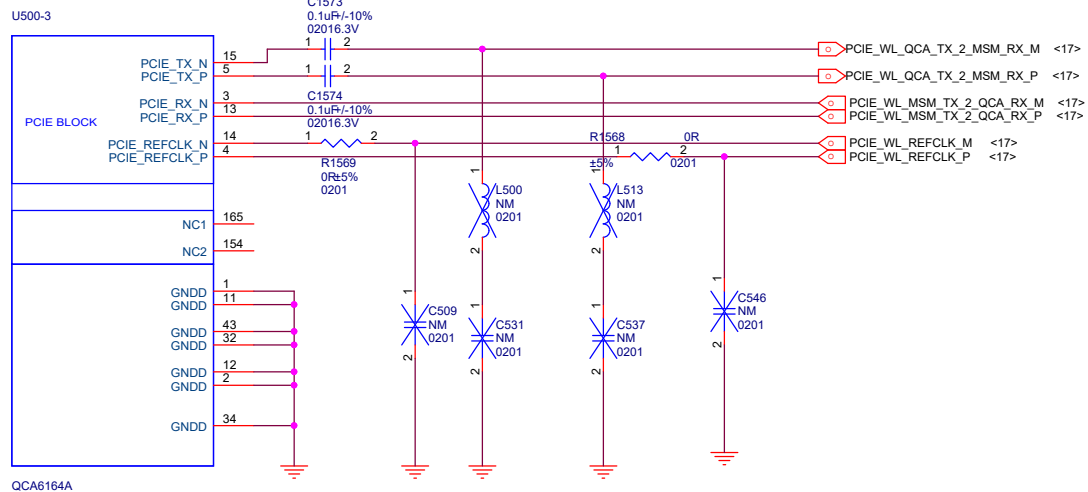
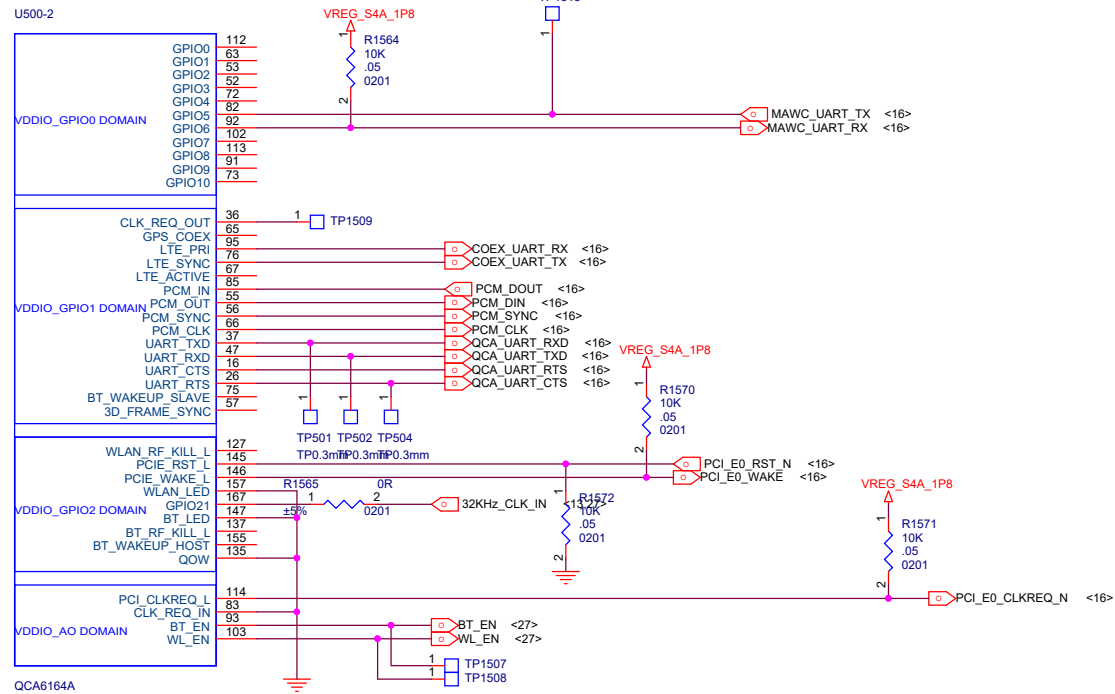

WIFI INTERFACE

Title			A1
Size	Document Number	Rev	
A3	<Doc>	P0	
Date:	Friday, August 05, 2016	Sheet	9 of 37

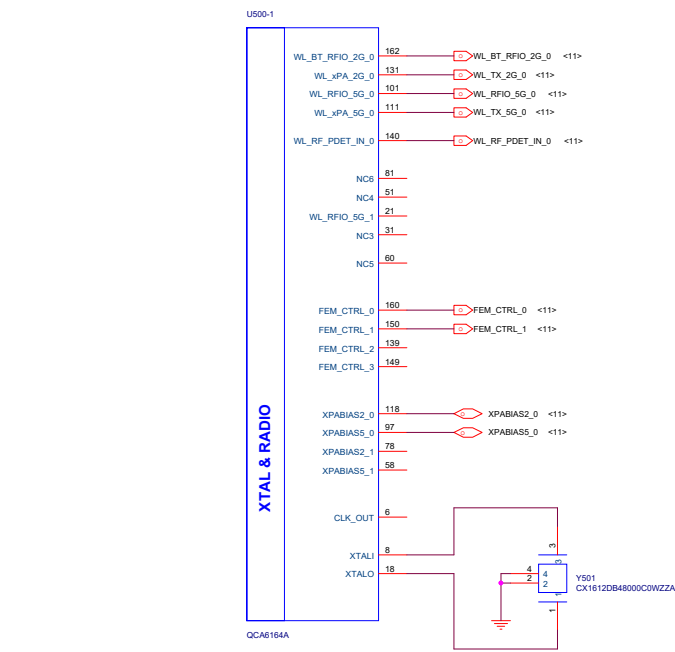
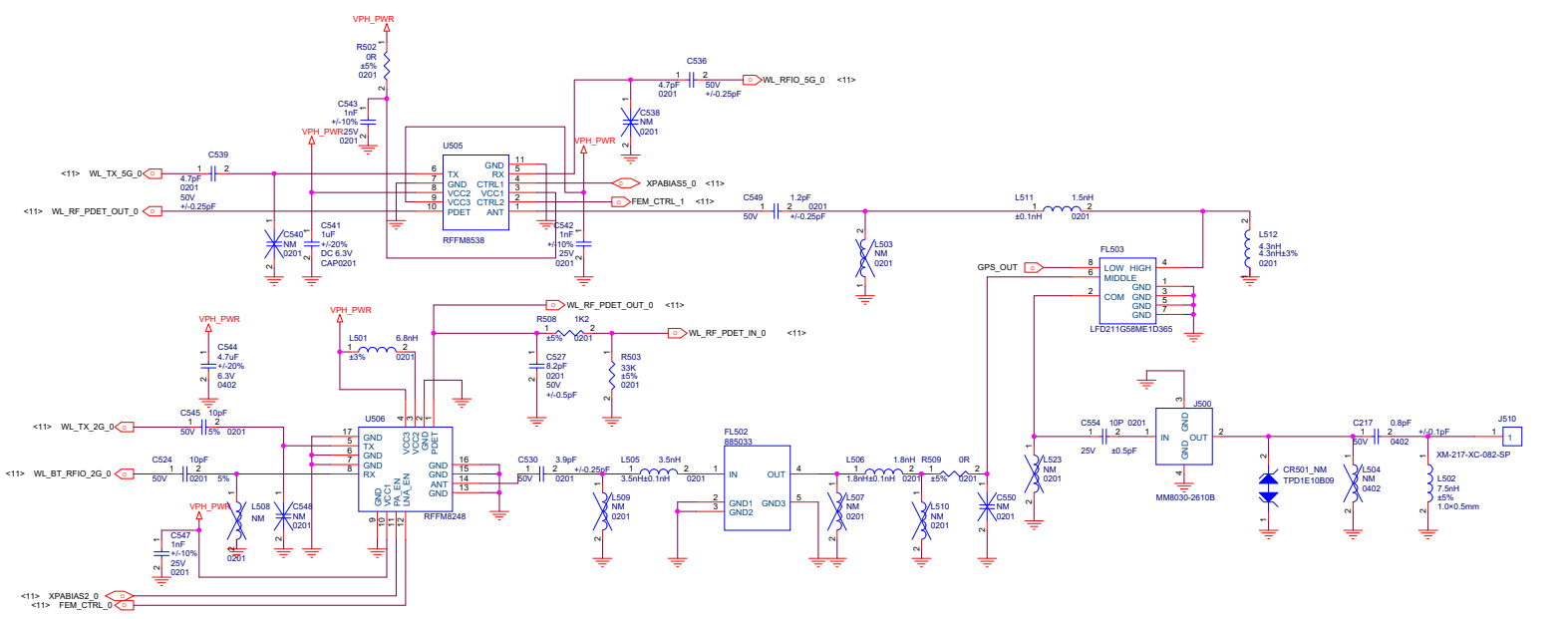

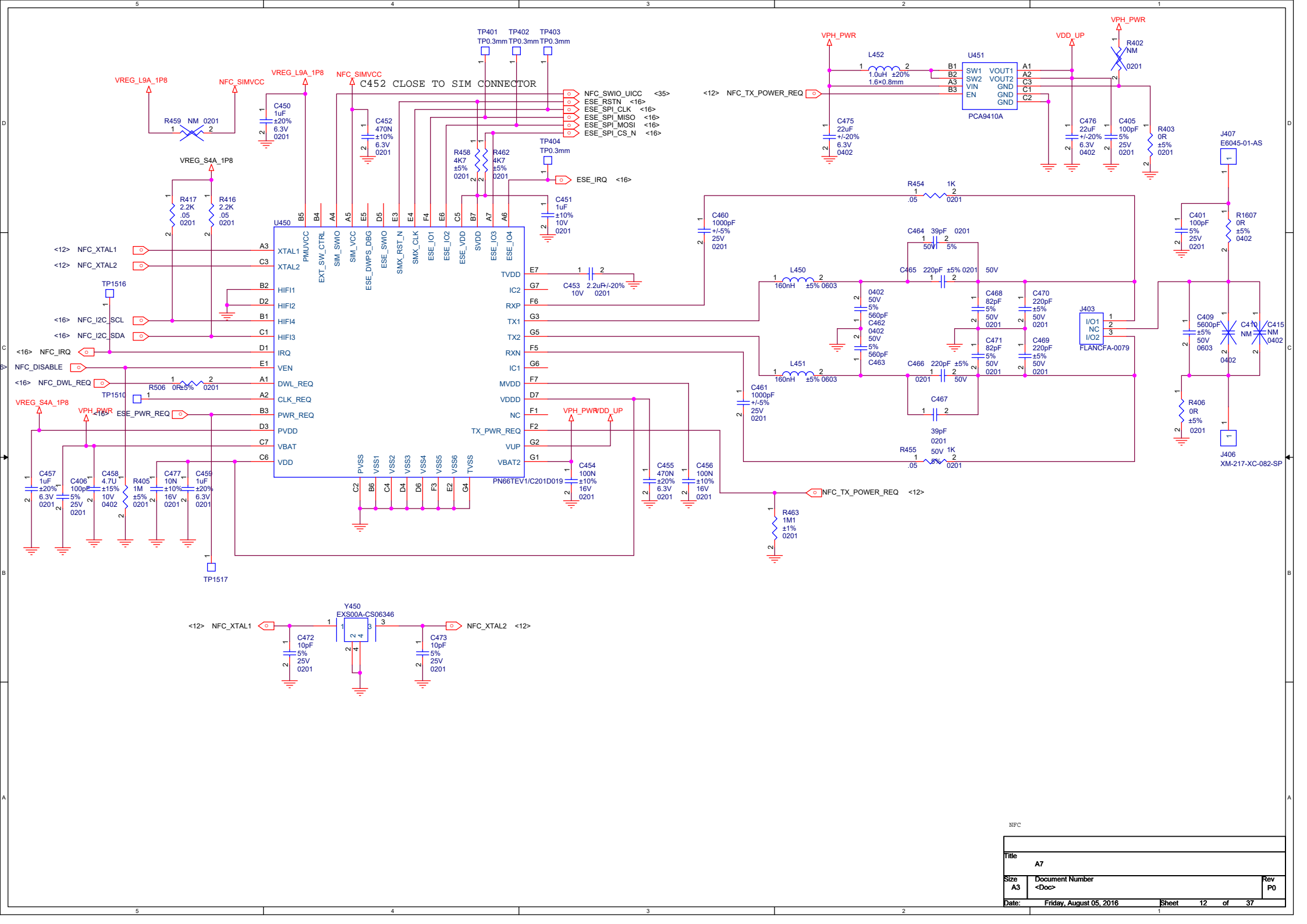

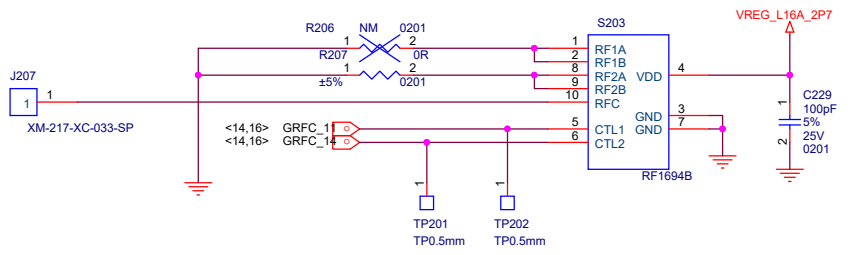
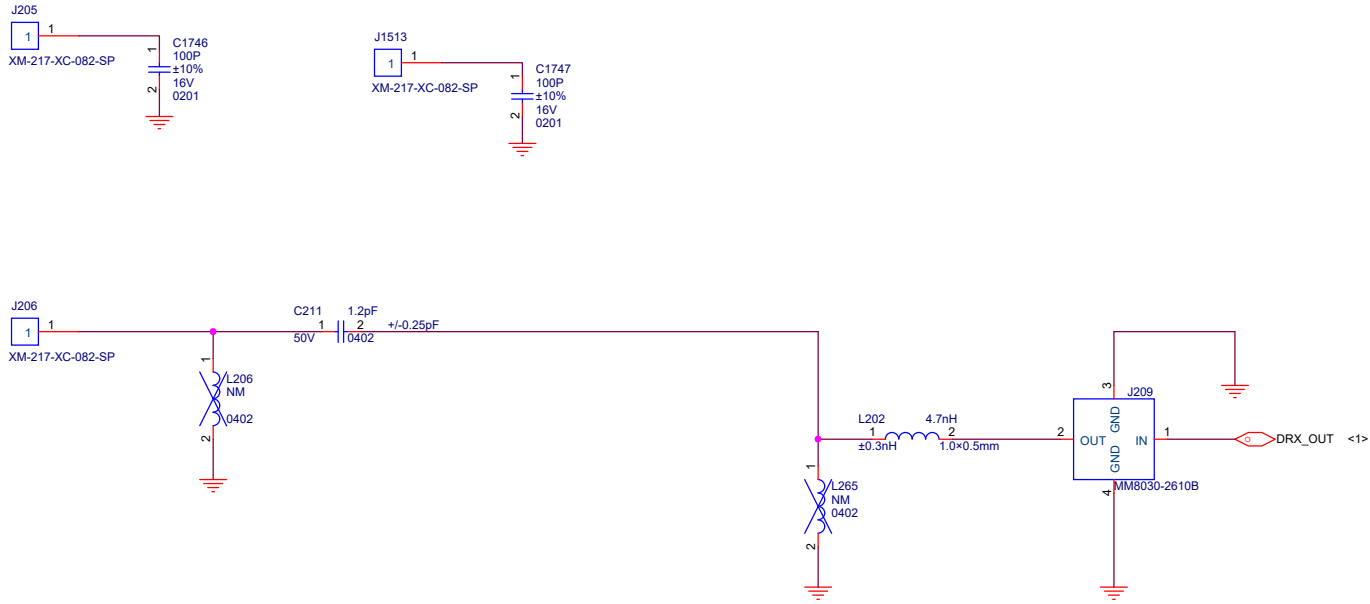

TUNER

Title		
A1		
Size	Document Number	Rev
A3	<Doc>	P0
Date:	Friday, August 05, 2016	Sheet 14 of 37

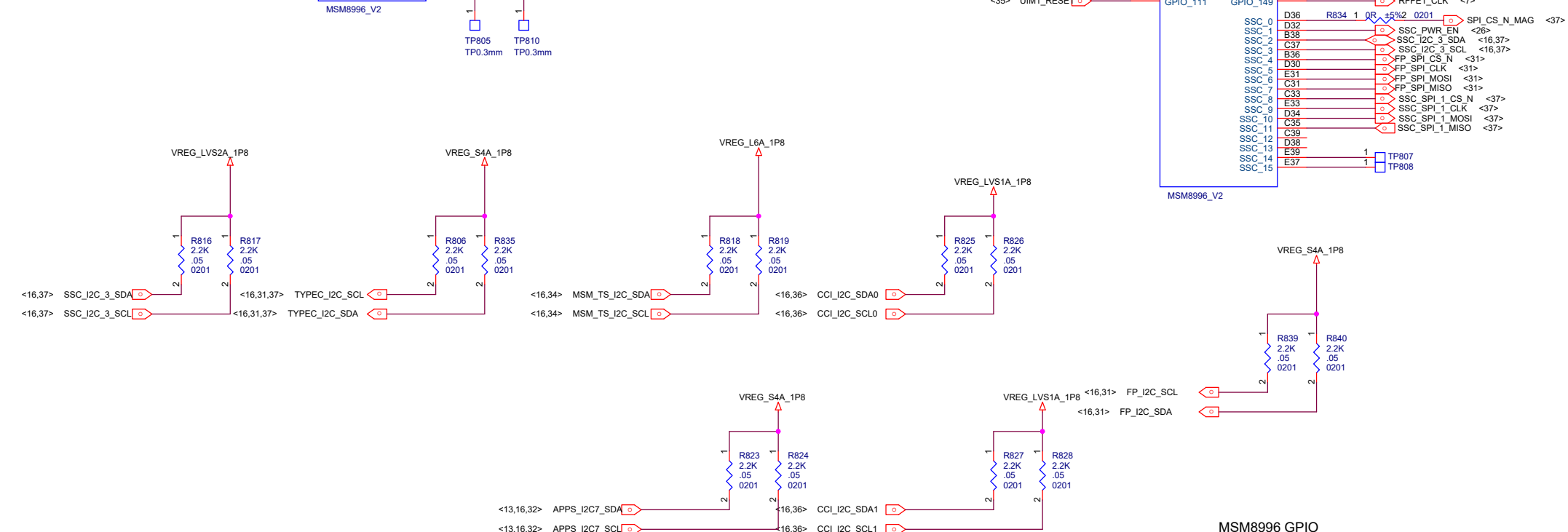
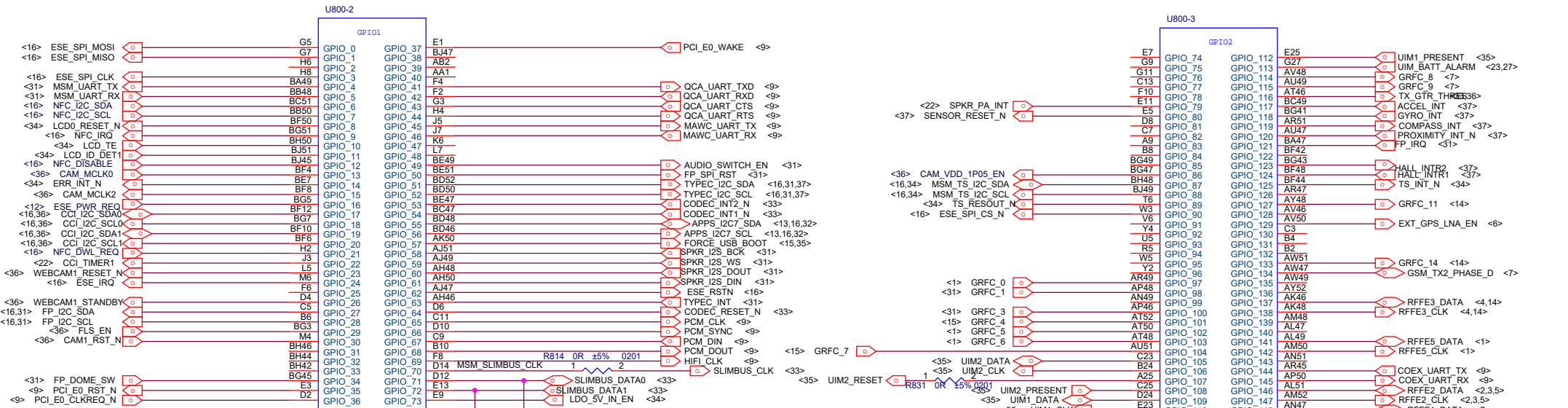

MSM8996 GPIO			
Title	A1		
Size	Document Number	Rev Po	
A3	<Doc>		
Date:	Friday, August 05, 2016	Sheet	16 of 37

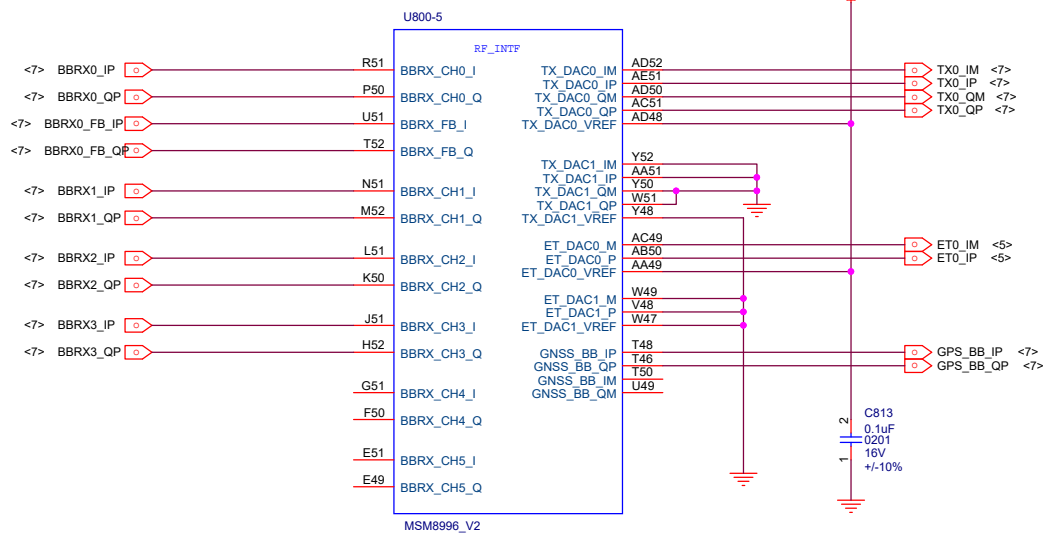
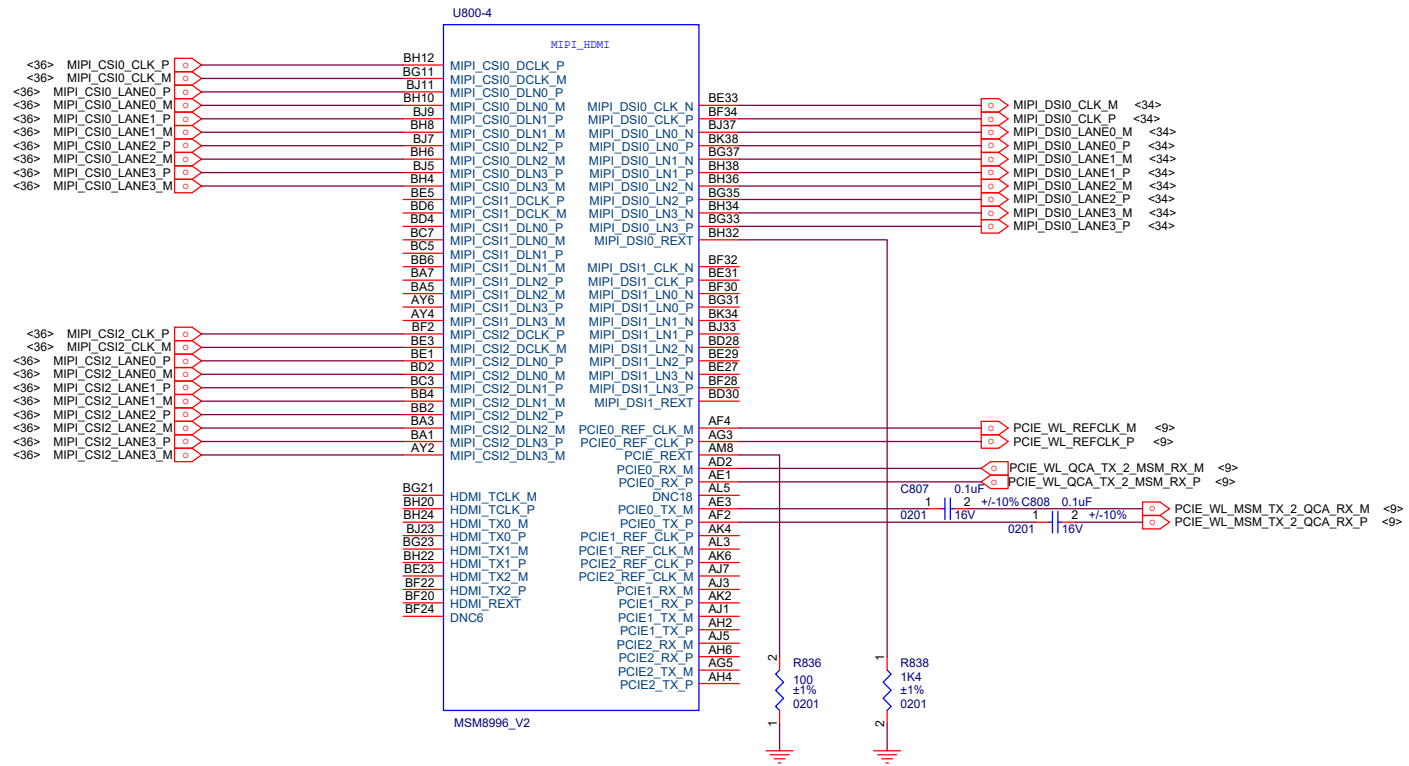

MSM8996 MIPI

Title		A1	
Size	A3	Document Number	<Doc>
Date:	Friday, August 05, 2016	Sheet	17 of 37
Rev	P0		

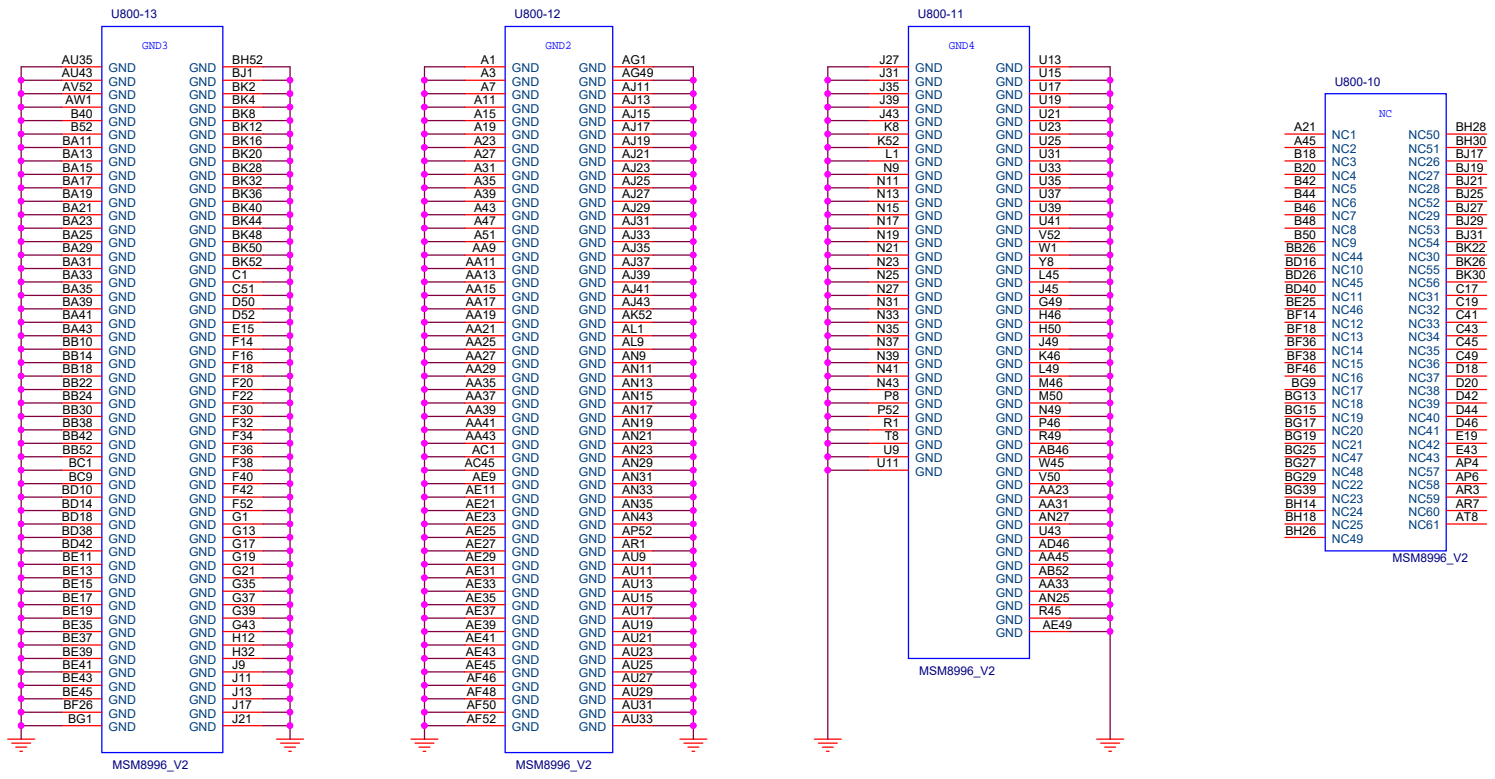

MSM8996 GND

Title		
A1		
Size	Document Number	Rev
A3	<Doc>	P0
Date:	Friday, August 05, 2016	Sheet 20 of 37

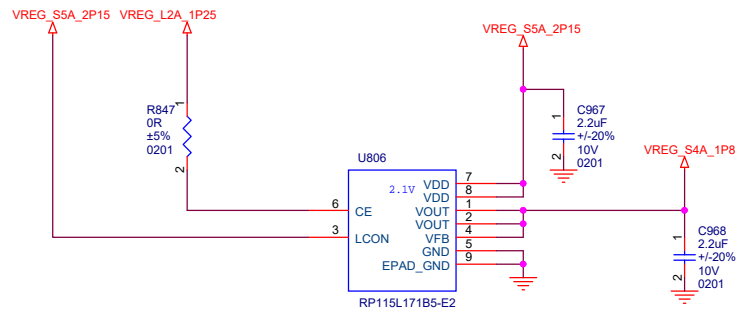

MSM8996 LPDDR REGULATOR

Title		
A1		
Size	Document Number	Rev
A3	<Doc>	P0
Date:	Friday, August 05, 2016	Sheet 21 of 37

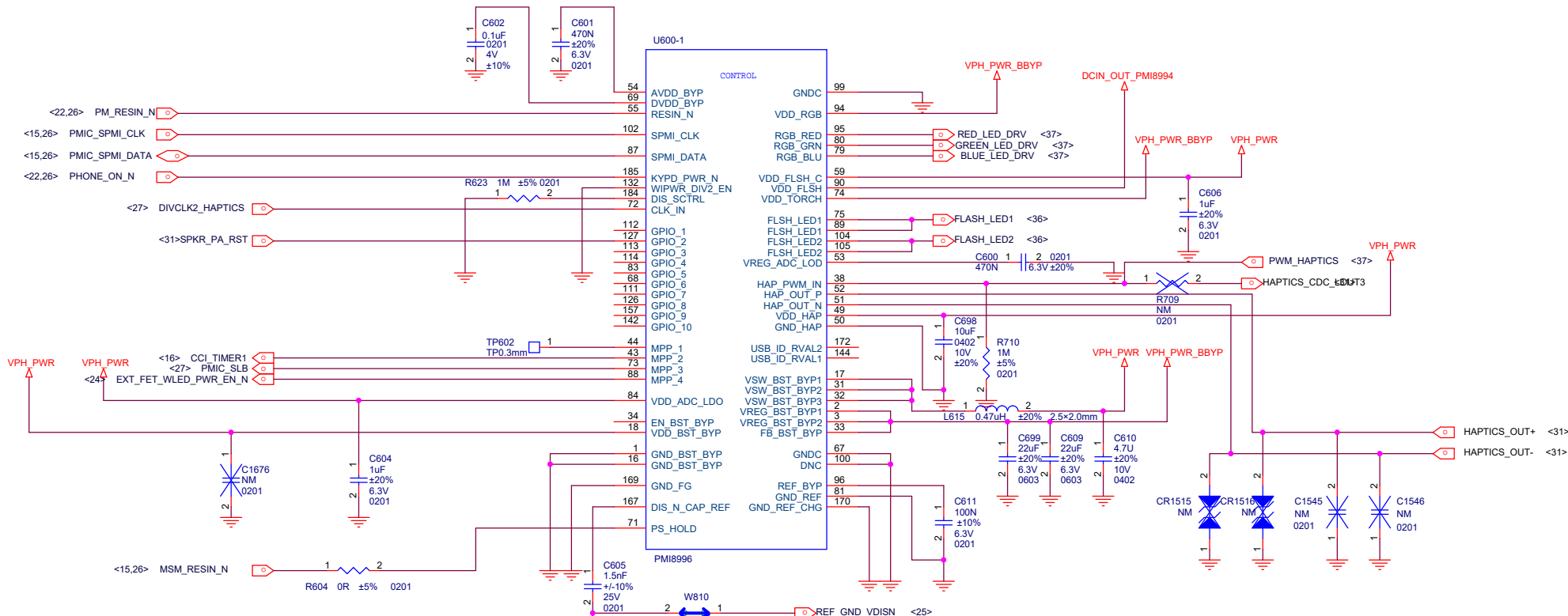

To be confirmed!

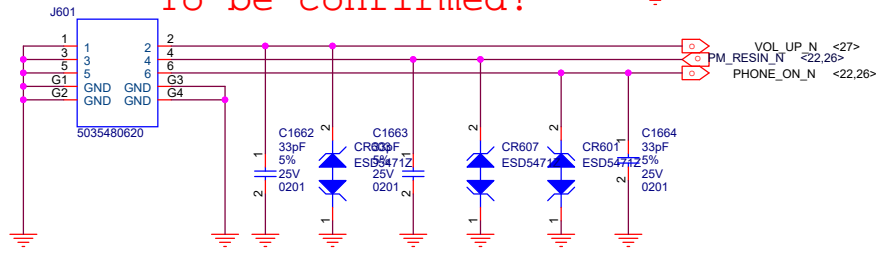

PMI8994 CONTROL

Title		
A1		
Size	Document Number	Rev
A3	<Doc>	P0
Date:	Friday, August 05, 2016	Sheet 22 of 37

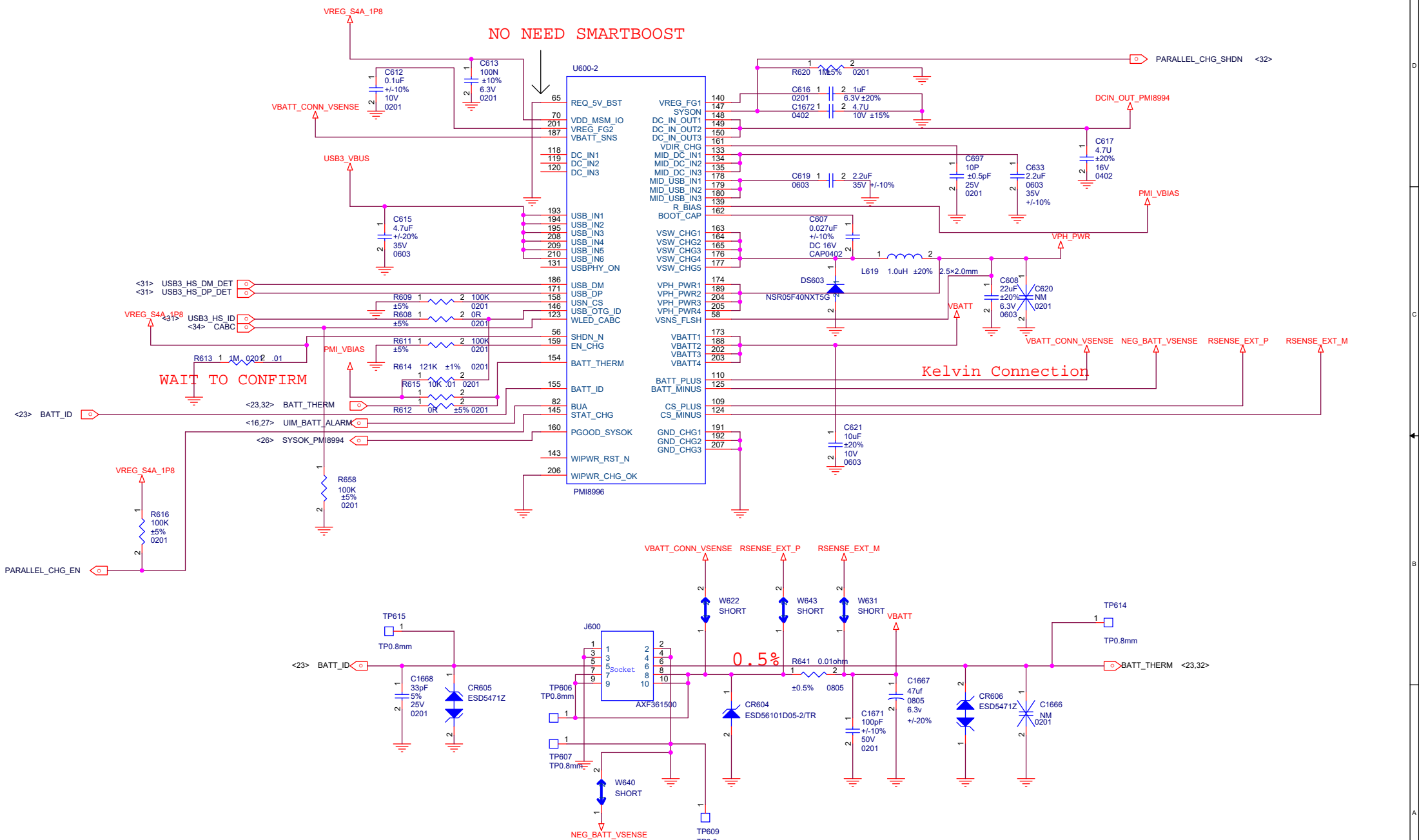

PMI8994 CHAGER&CLOCKS

Title	A1	
Size	Document Number	Rev
A3	<Doc>	P0
Date:	Friday, August 05, 2016	Sheet 23 of 37

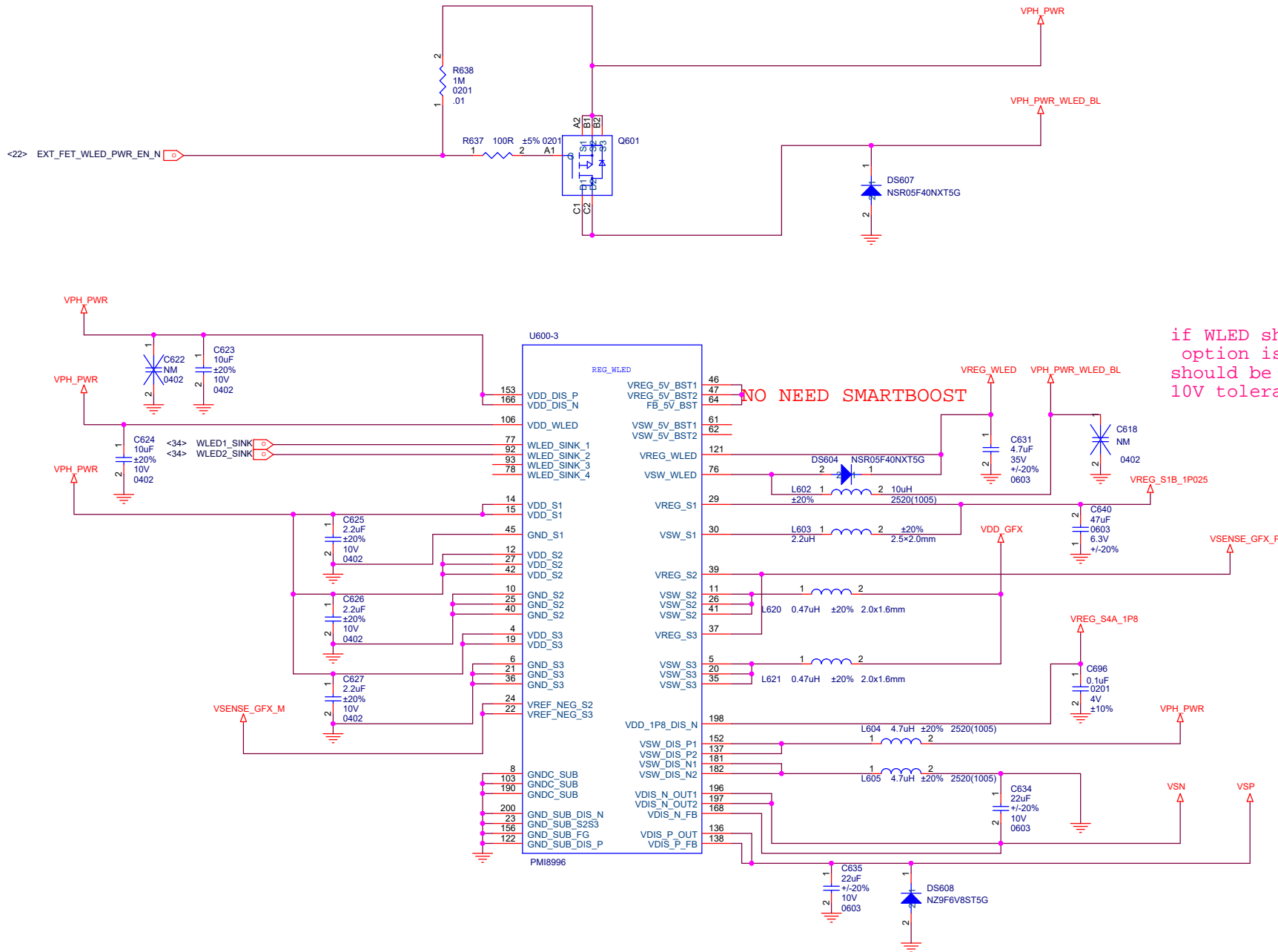

if WLED short circuit protection option is not used, C1670 should be changed to 10uF, 10V tolerance capacitor

NO NEED SMARTBOOST

PM18994 REG WLED

Title		
A1		
Size	Document Number	Rev
A3	<Doc>	P0
Date:	Friday, August 05, 2016	Sheet 24 of 37

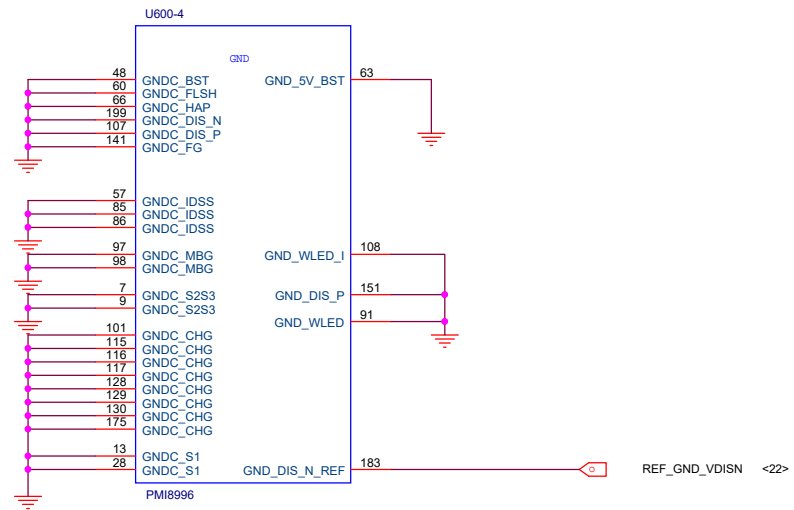

CAD NOTE: Connect to pin183 then GND with single via

PM18994 GND

Title		
A1		
Size	Document Number	Rev
A3	<Doc>	P0
Date:	Friday, August 05, 2016	Sheet 25 of 37

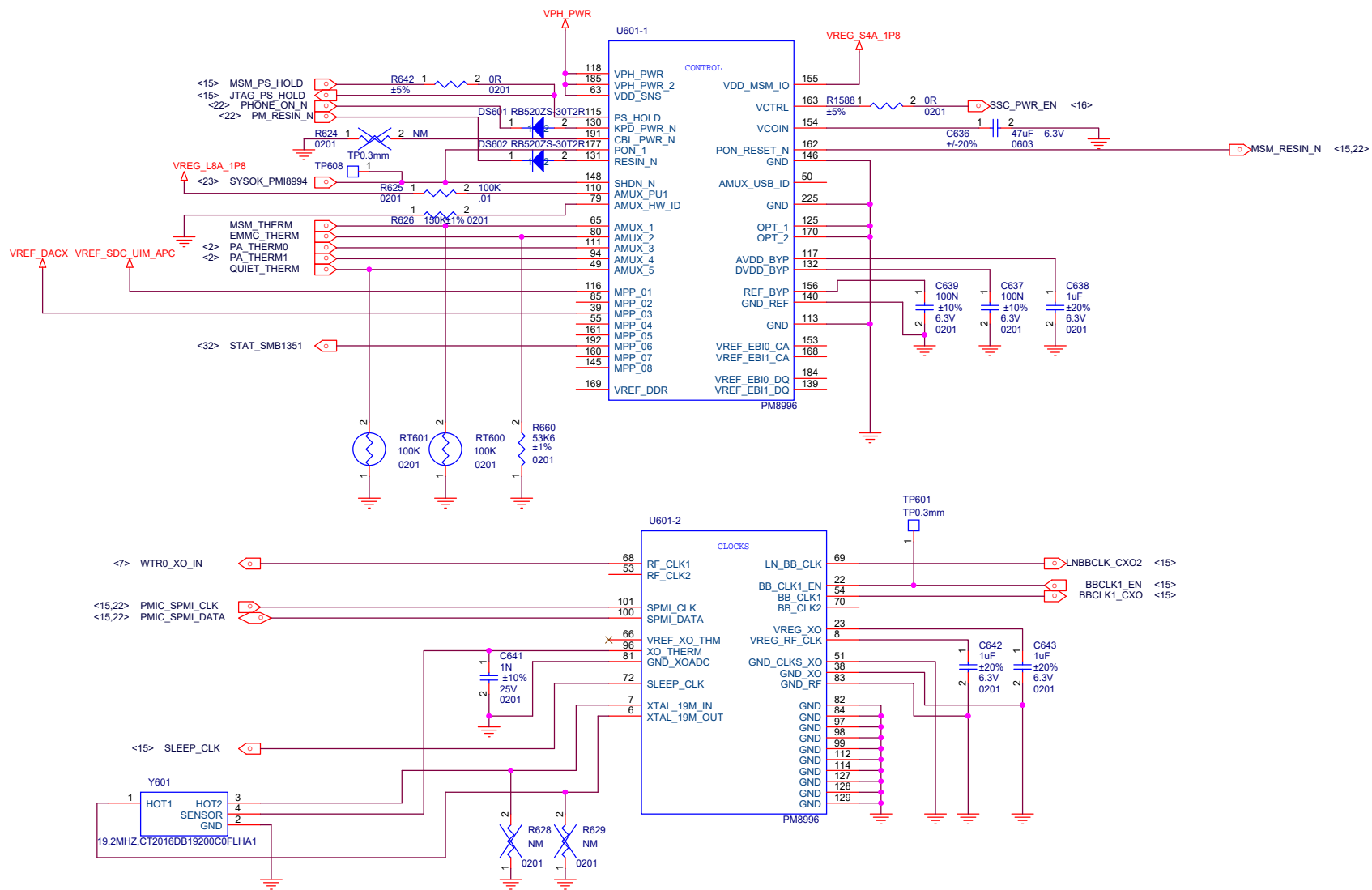

PM8996 CONTROL

Title		
A1		
Size	Document Number	Rev
A3	<Doc>	P0
Date:	Friday, August 05, 2016	Sheet 26 of 37

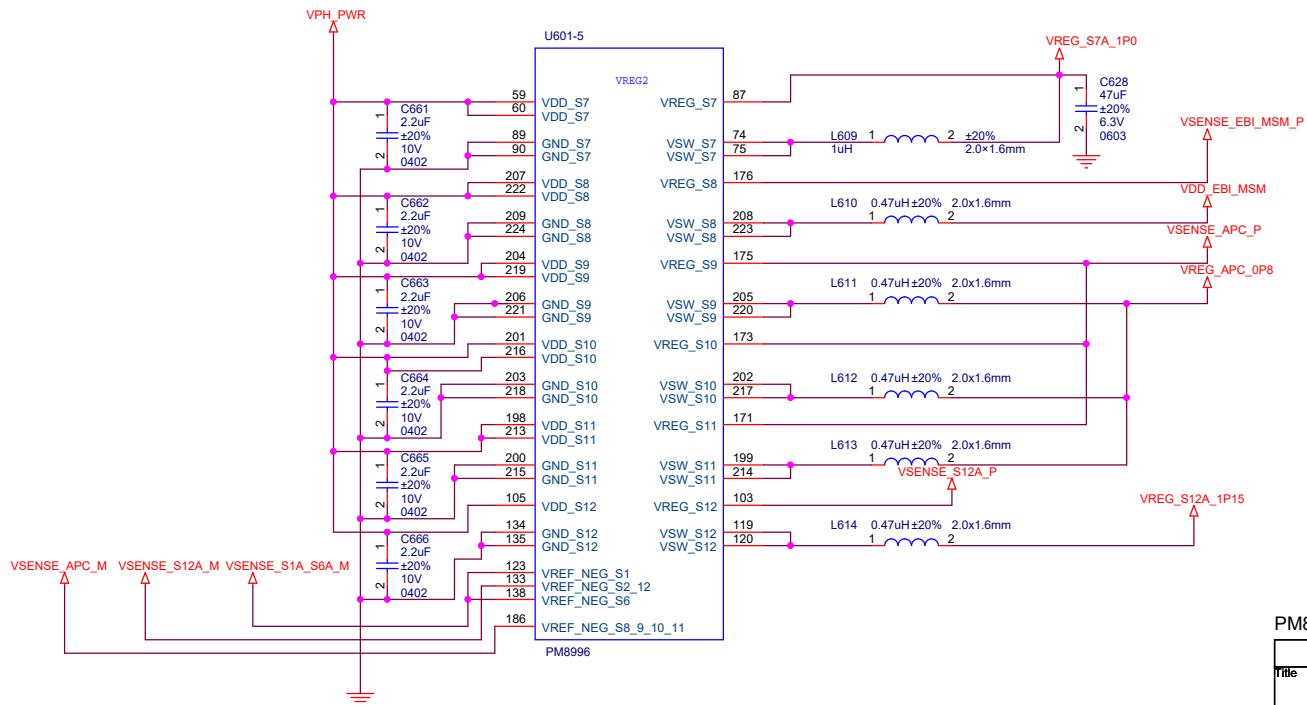
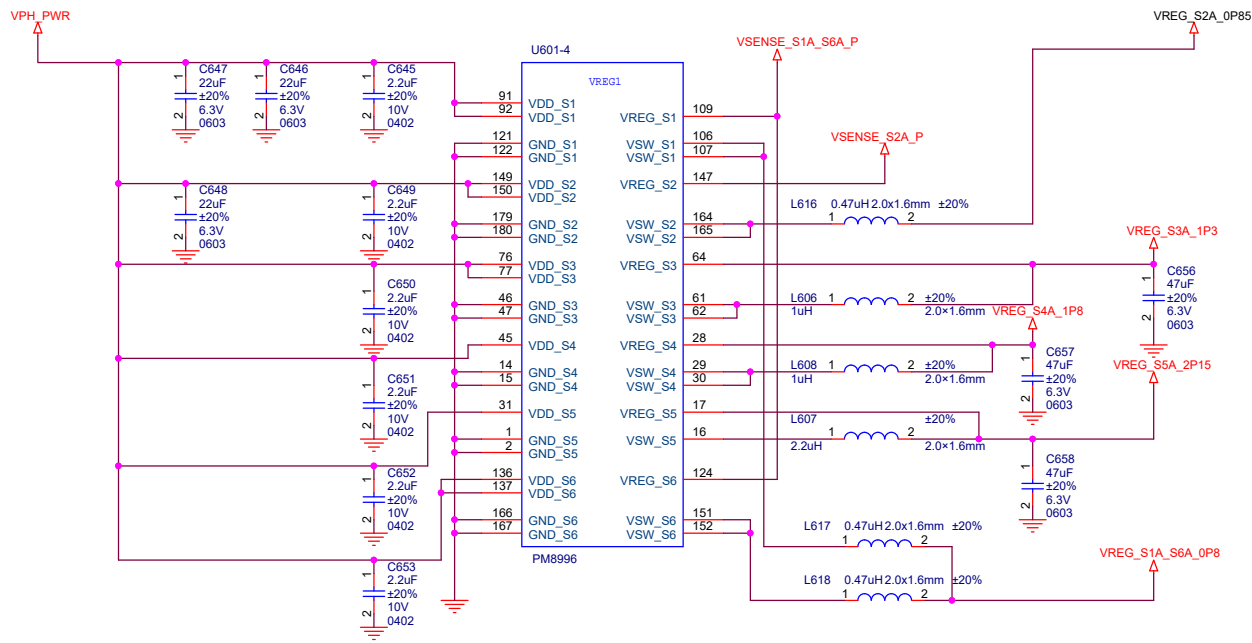

PM8996 VREG

Title		
A1		
Size	Document Number	Rev
A3	<Doc>	P0
Date:	Friday, August 05, 2016	Sheet 28 of 37

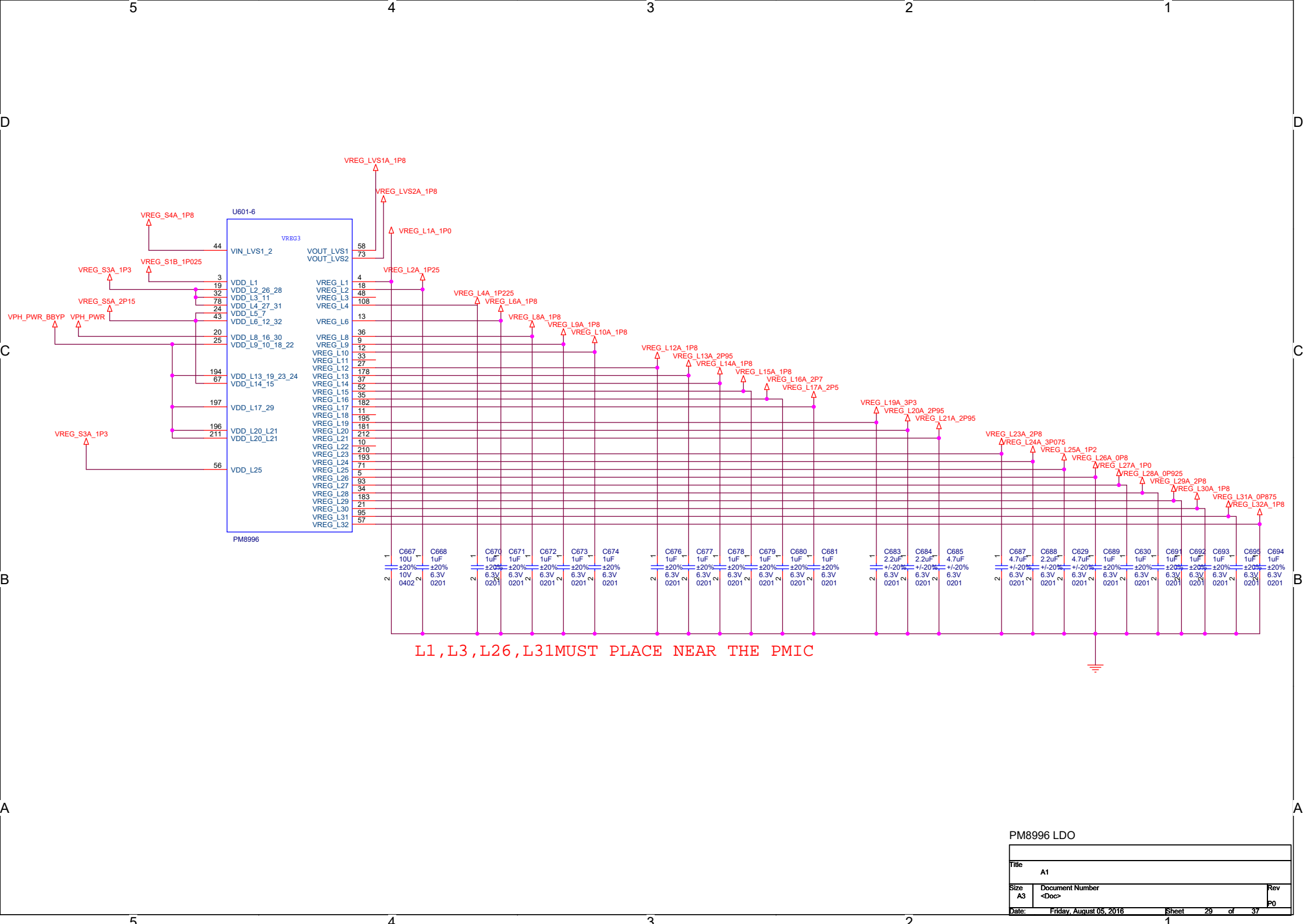

L1, L3, L26, L31 MUST PLACE NEAR THE PMIC

PM8996 LDO			
Title	A1		
Size	A3	Document Number	<Doc>
Rev	P0		
Date:	Friday, August 05, 2016	Sheet	29 of 37

HANDSET

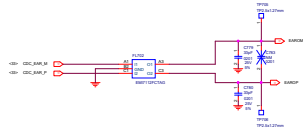

AUX Mic2

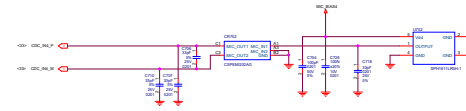

HEADSET

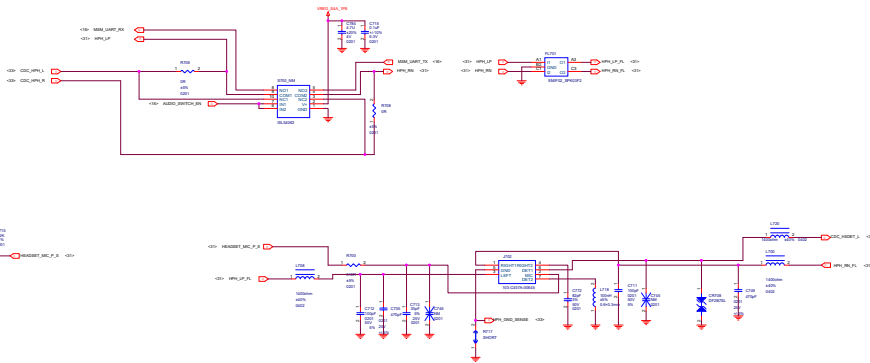

Speaker PA

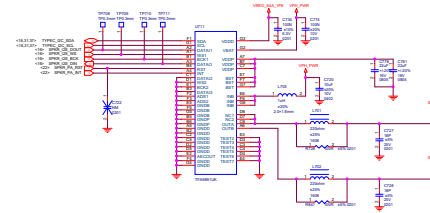

AUX Mic1

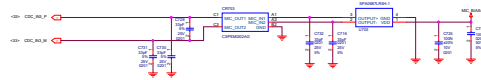

KEYPAD LED DRIVER

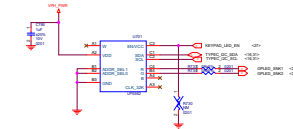

Bottom fpc Connector

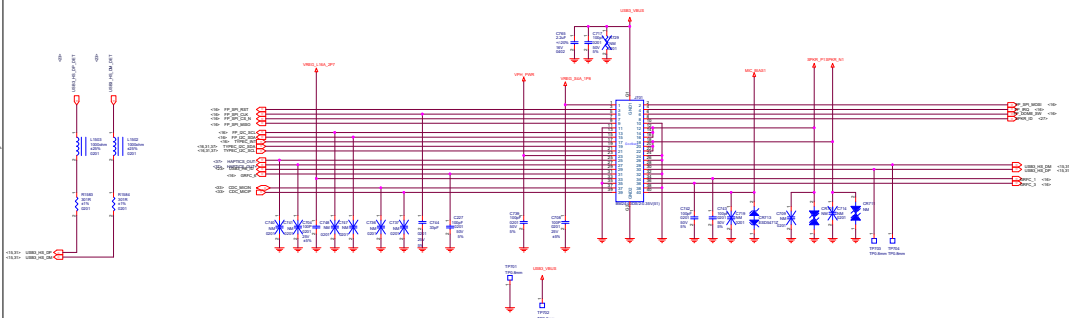

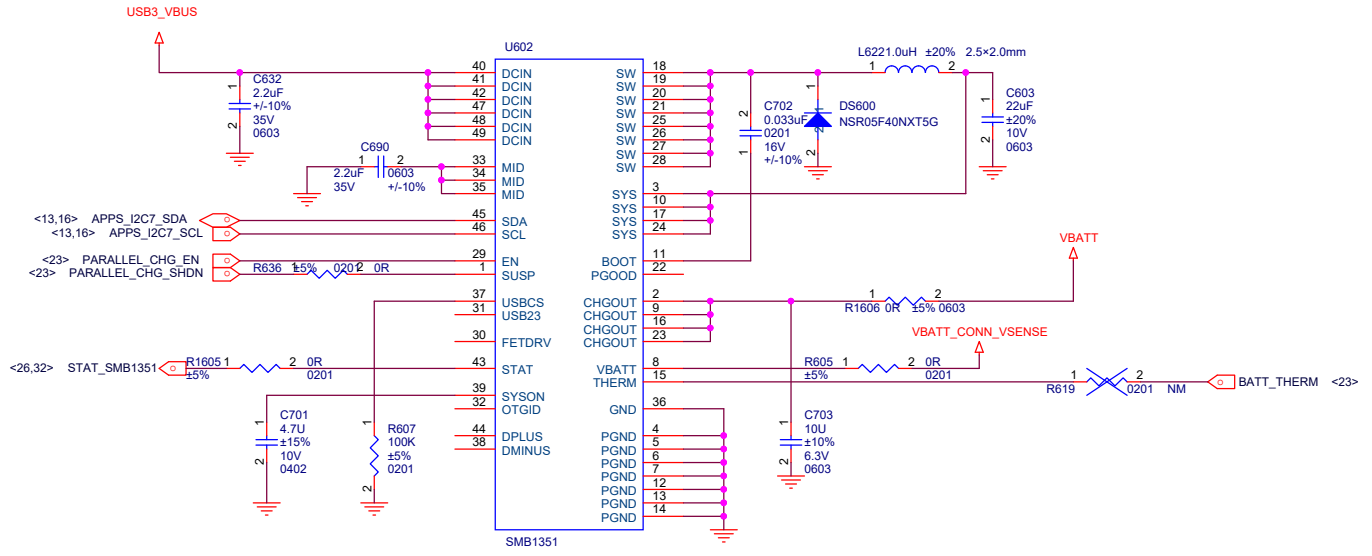

SMB1351 CHARGER

Title		
A1		
Size	Document Number	Rev
A3	<Doc>	P0
Date:	Friday, August 05, 2016	Sheet 32 of 37

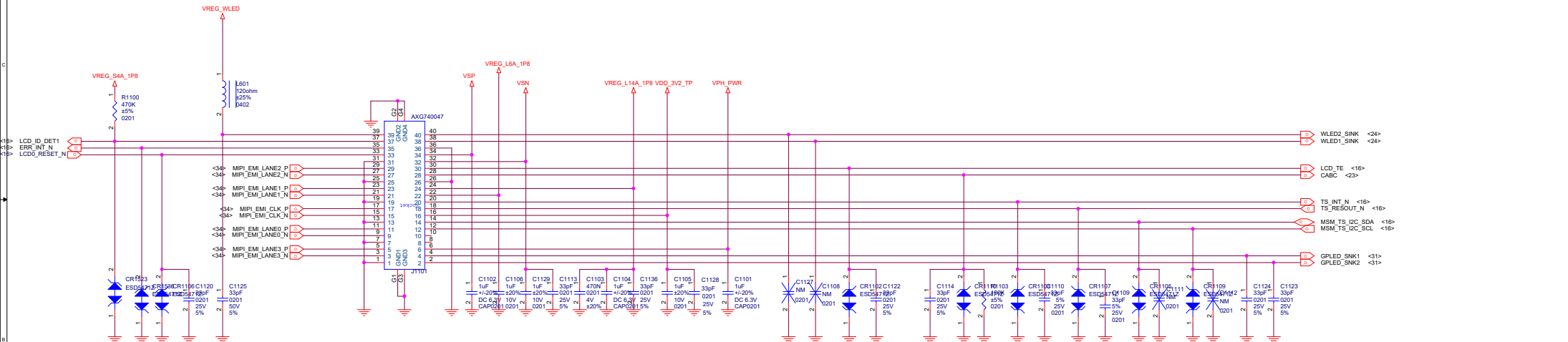
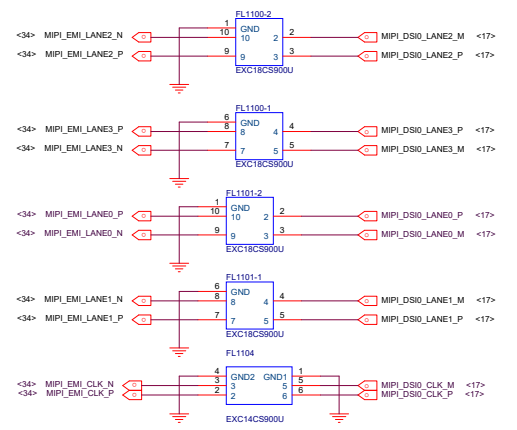
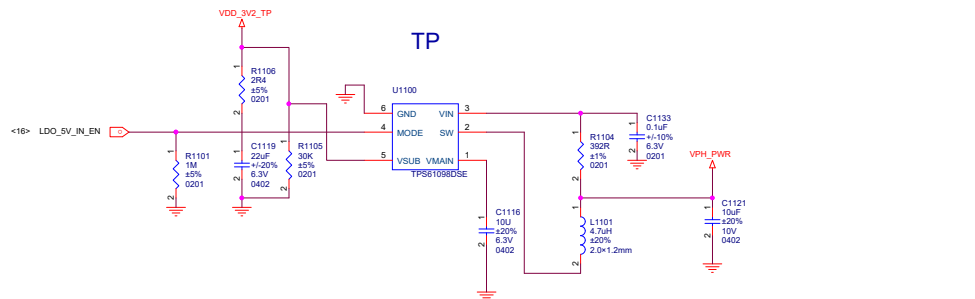

LCD

XIAO MI			
File	A1		
Size	Document Number		Rev
A2	LCD		PD
Date:	Friday, August 05, 2016	Sheet	34 of 37

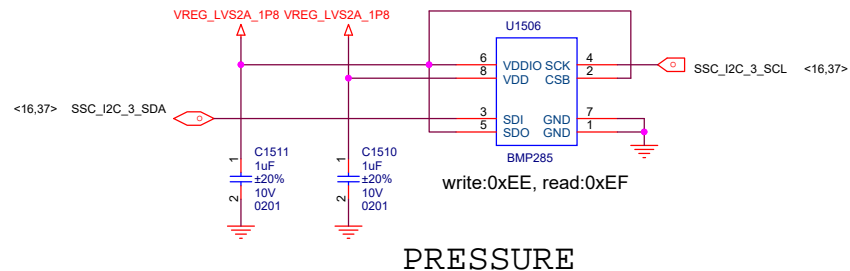
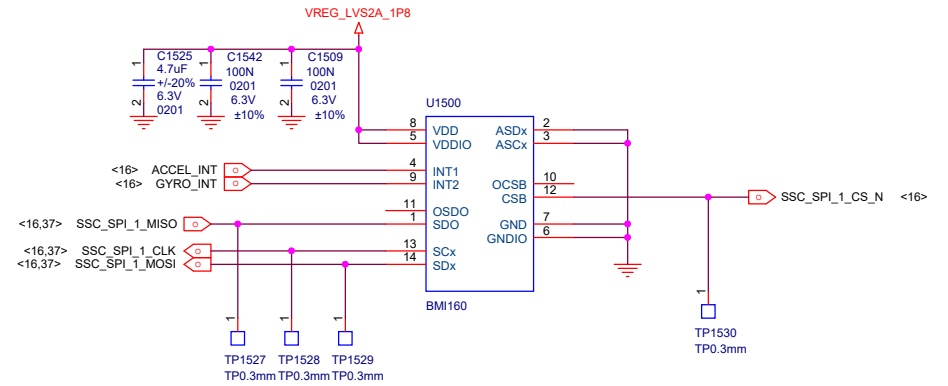
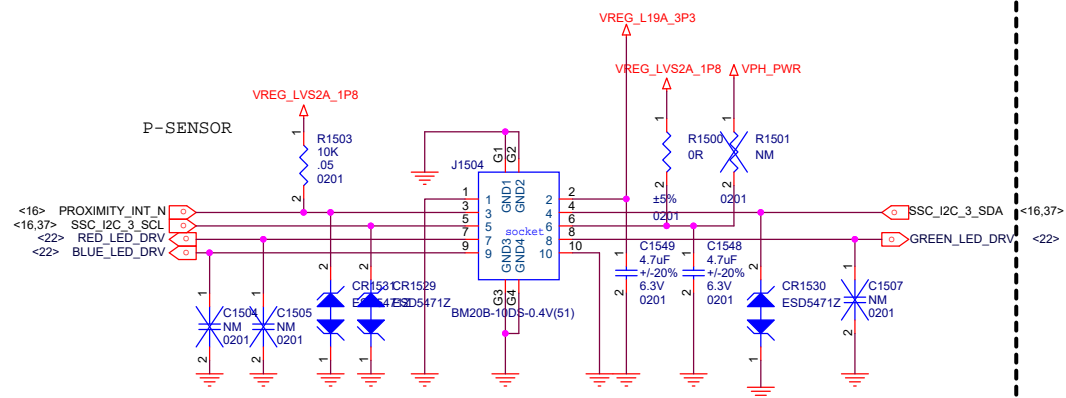

PRESSURE

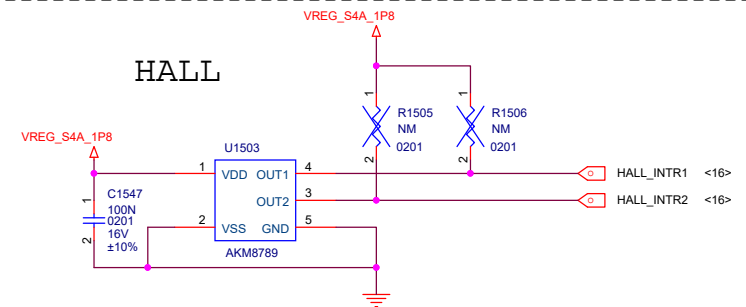

HALL

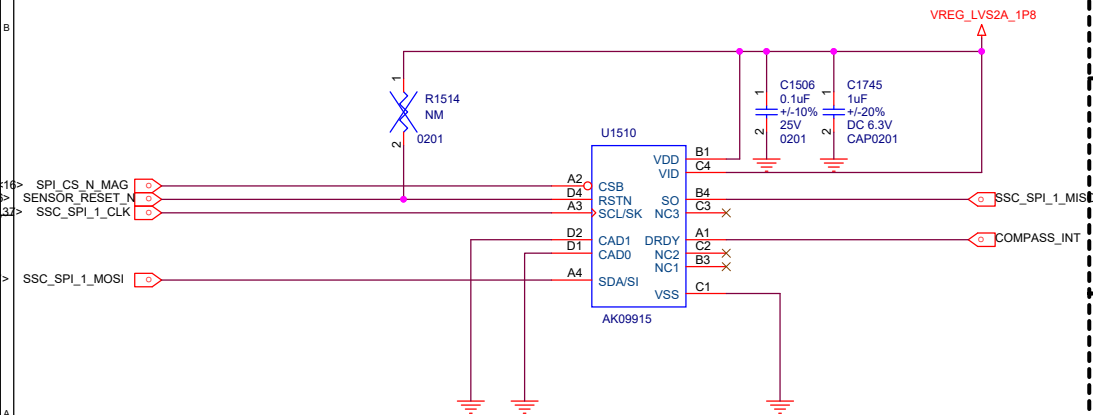

COMPASS

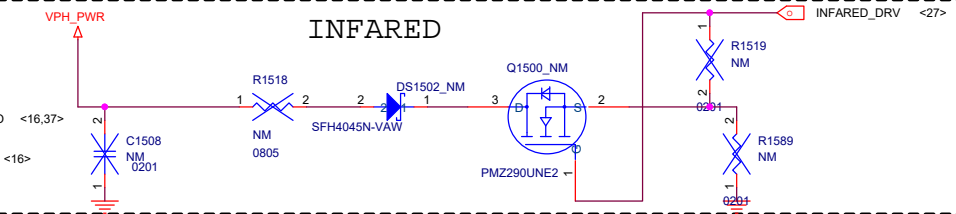

INFRARED

SENSOR			
Title	A1		
Size	Document Number	Rev	P0
A3	<Doc>		
Date:	Sheet	37	of 37