

### PRIMARY SWITCH(SP16T) LOGIC

Antenna Path	Bit[7]	Bit[6]	Bit[5]	Bit[4]	Bit[3]	Bit[2]	Bit[1]	Bit[0]
Sleep mode (standby)	X	0	0	0	0	0	0	0
2G transmit low band	X	0	0	0	1	0	1	0
2G transmit high band	X	0	0	0	1	0	0	0
TRX1	X	0	0	0	0	1	0	0
TRX2	X	0	0	0	0	1	0	1
TRX3	X	0	0	0	0	1	1	0
TRX4	X	0	0	0	0	1	1	1
TRX5	X	0	0	0	1	0	0	1
TRX6	X	0	0	0	1	0	1	1
TRX7	X	0	0	0	1	1	0	0
TRX8	X	0	0	0	0	0	0	1
TRX9	X	0	0	0	0	0	1	0
TRX10	X	0	0	0	0	0	1	1
TRX11	X	0	0	0	1	1	0	1
TRX12	X	0	0	0	1	1	1	0
TRX13	X	0	0	1	0	0	0	0
TRX14	X	0	0	1	0	0	0	1
Isolation mode (warm-up)	X	1	1	1	1	1	1	1

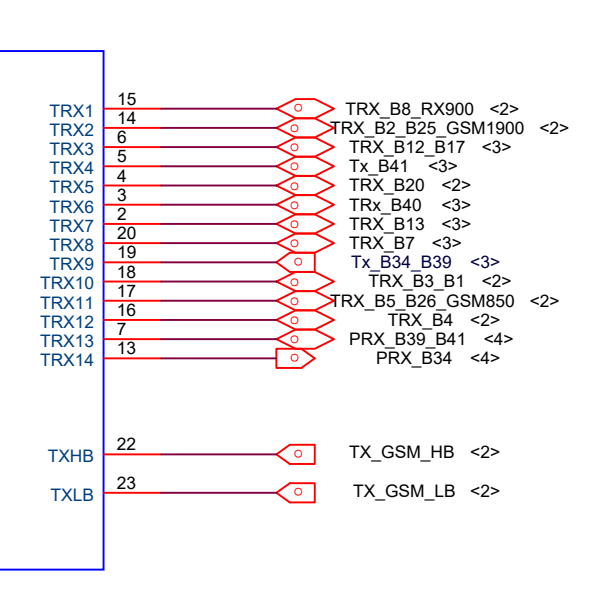
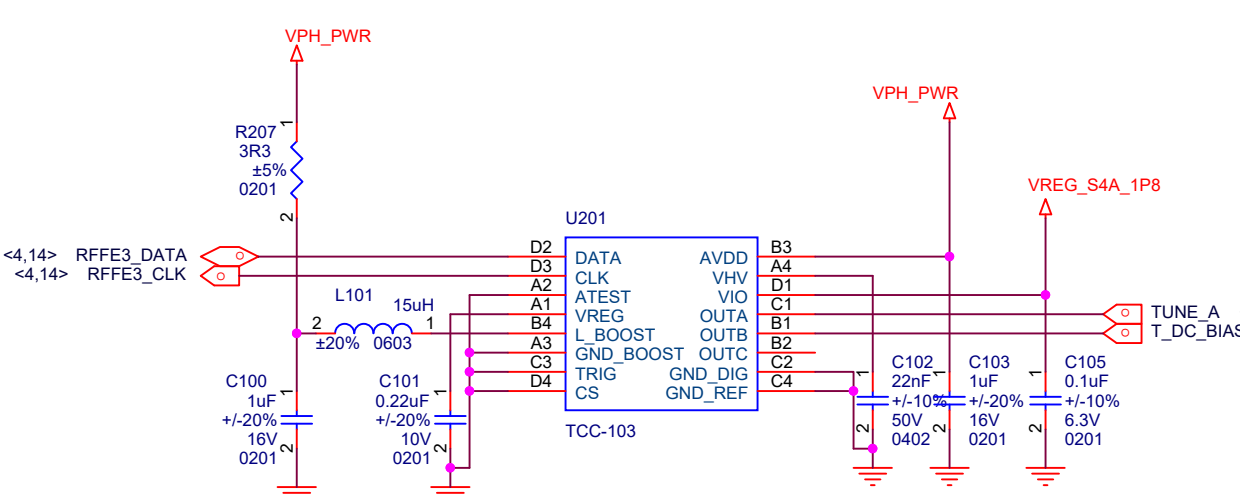

CXM3593		
CTL 1	CTL 2	Active path
L	H	RF1-RF4 RF2-RF3
H	L	RF1-RF3 RF2-RF4

#### Primary Ant Connector, Coupler and Primary Switchplexer

Title		
B7		
Size	Document Number	Rev
A3	ANT CON&COUPLER&SWITCHPL	P0
Date:	Wednesday, August 17, 2016	Sheet 1 of 35

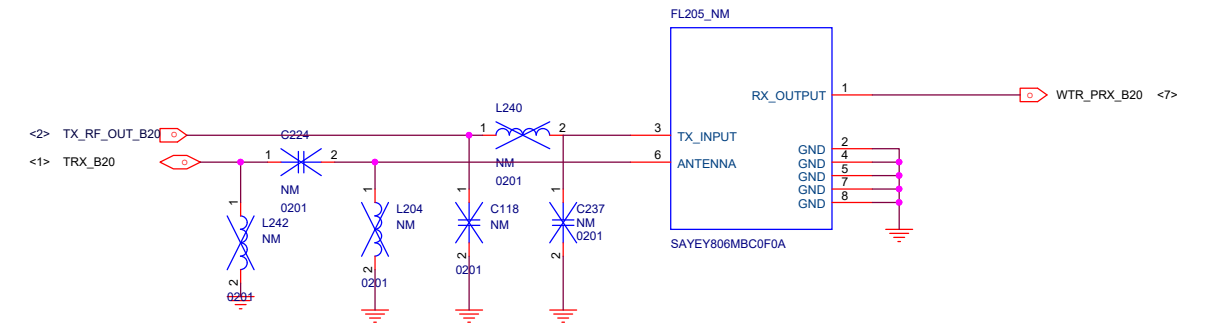
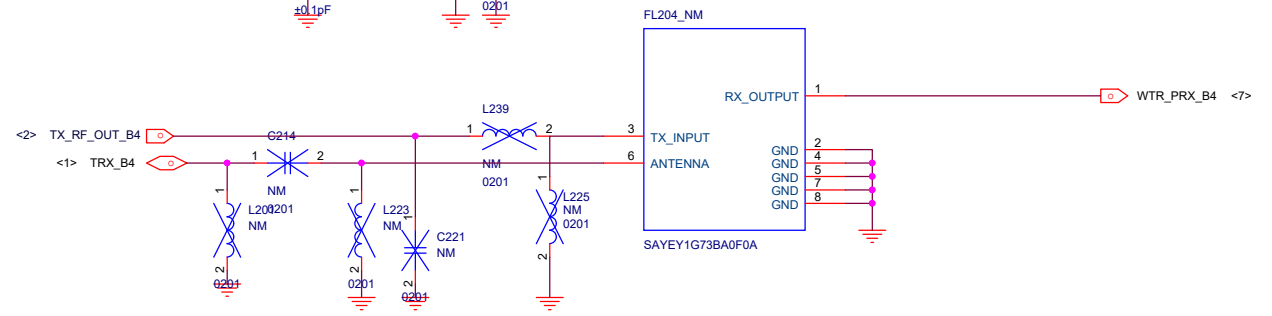
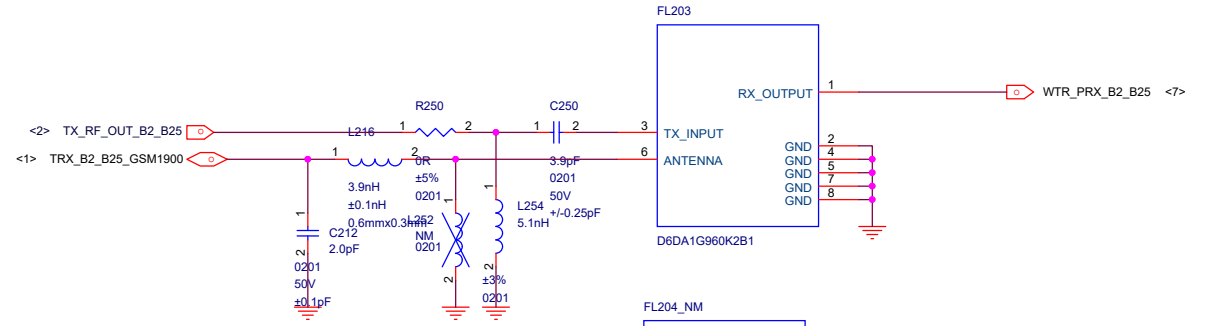
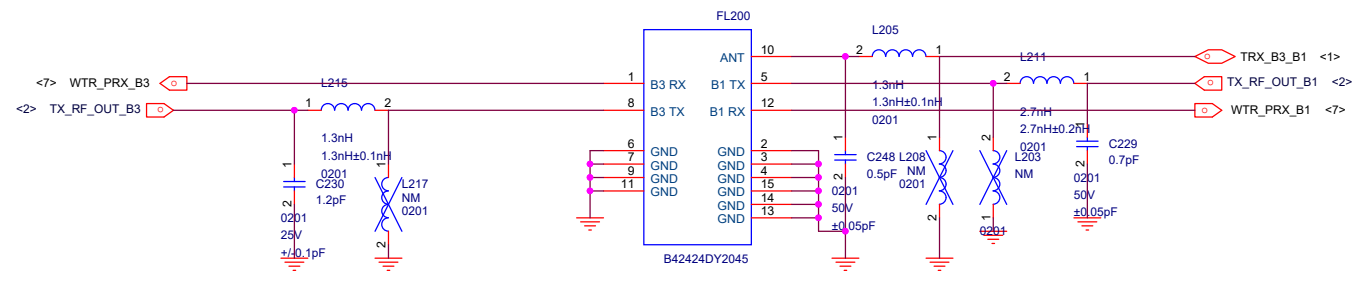
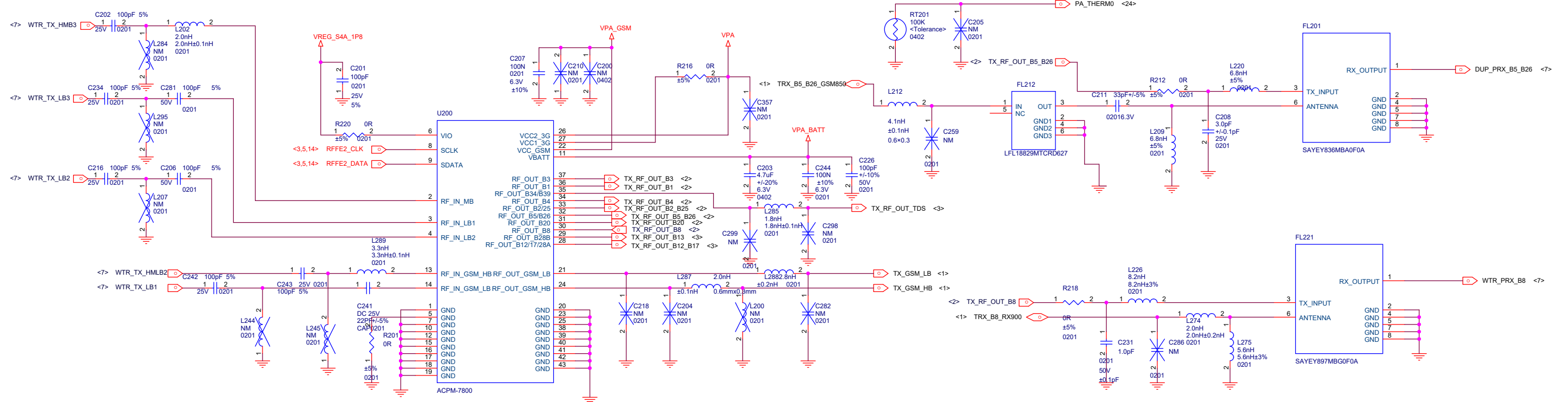

RF7301 LOGIC

POWER MODE	PA_ON3_B34_B39	TDS_PA0_R0	TDS_PA0_R1
POWER DOWN MODE	L	L	L
STANDBY MODE	L	X	X
HIGH POWER STATE	H	L	L
MEDIUM POWER STATE	H	H	L
LOW POWER STATE		H	H

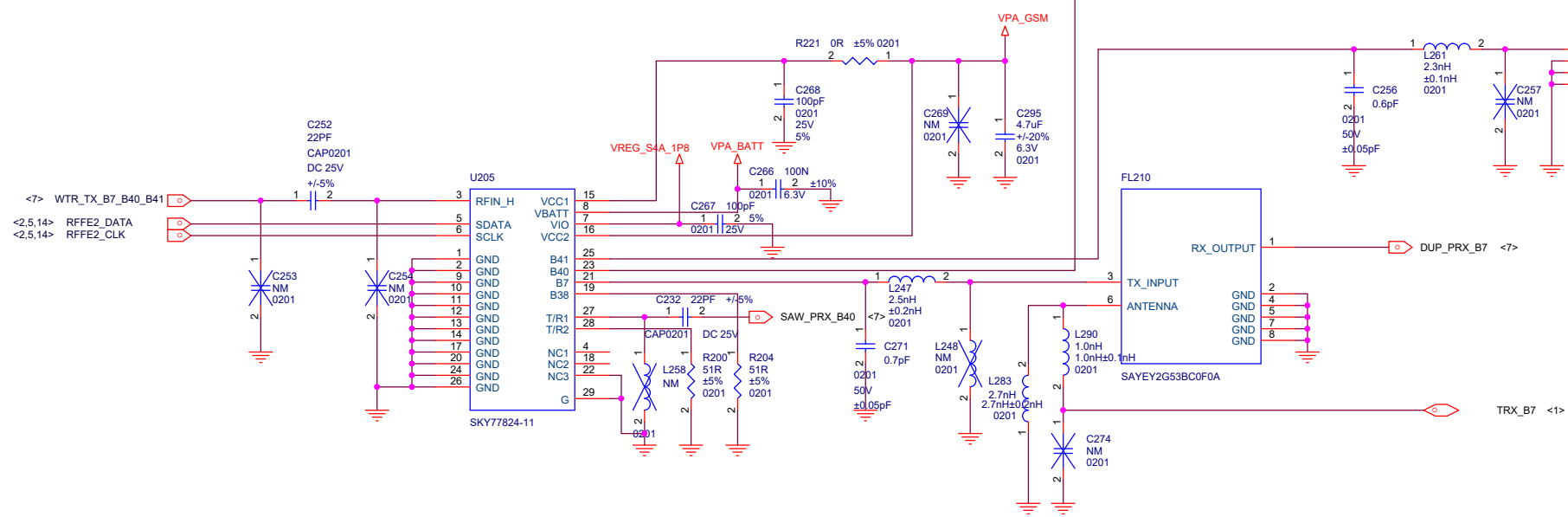
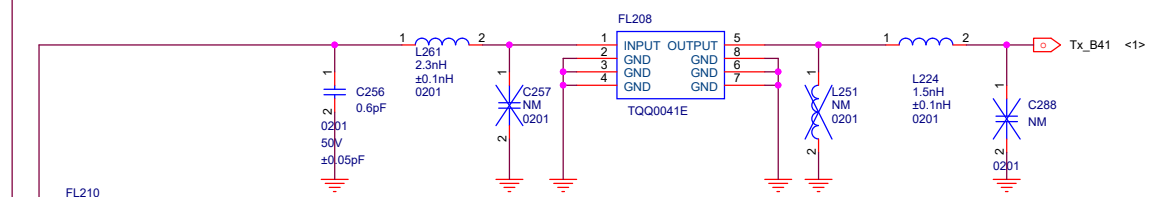
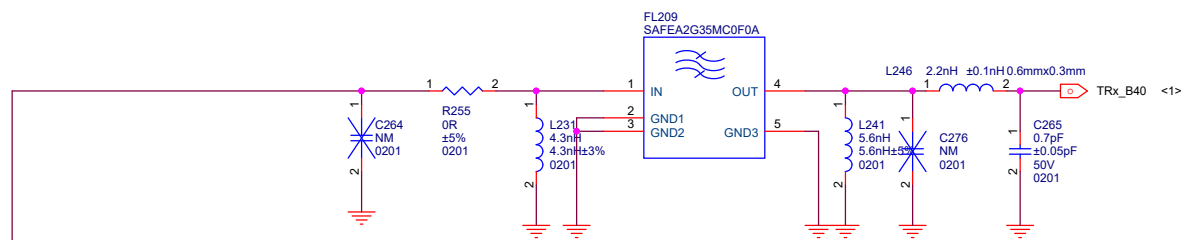
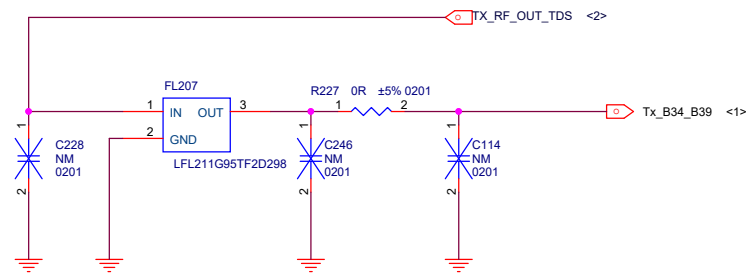
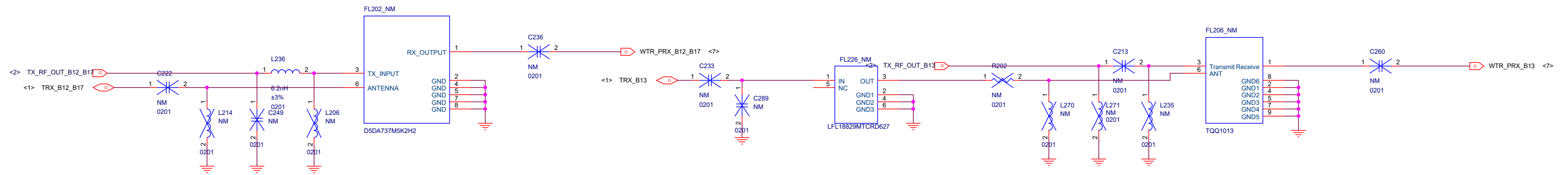

RF7301 LOGIC

POWER MODE	PA_ON3_B34_B39	TDS_PA0_R0	TDS_PA0_R1
POWER DOWN MODE	L	L	L
STANDBY MODE	L	X	X
HIGH POWER STATE	H	L	L
MEDIUM POWER STATE	H	H	L
LOW POWER STATE		H	H

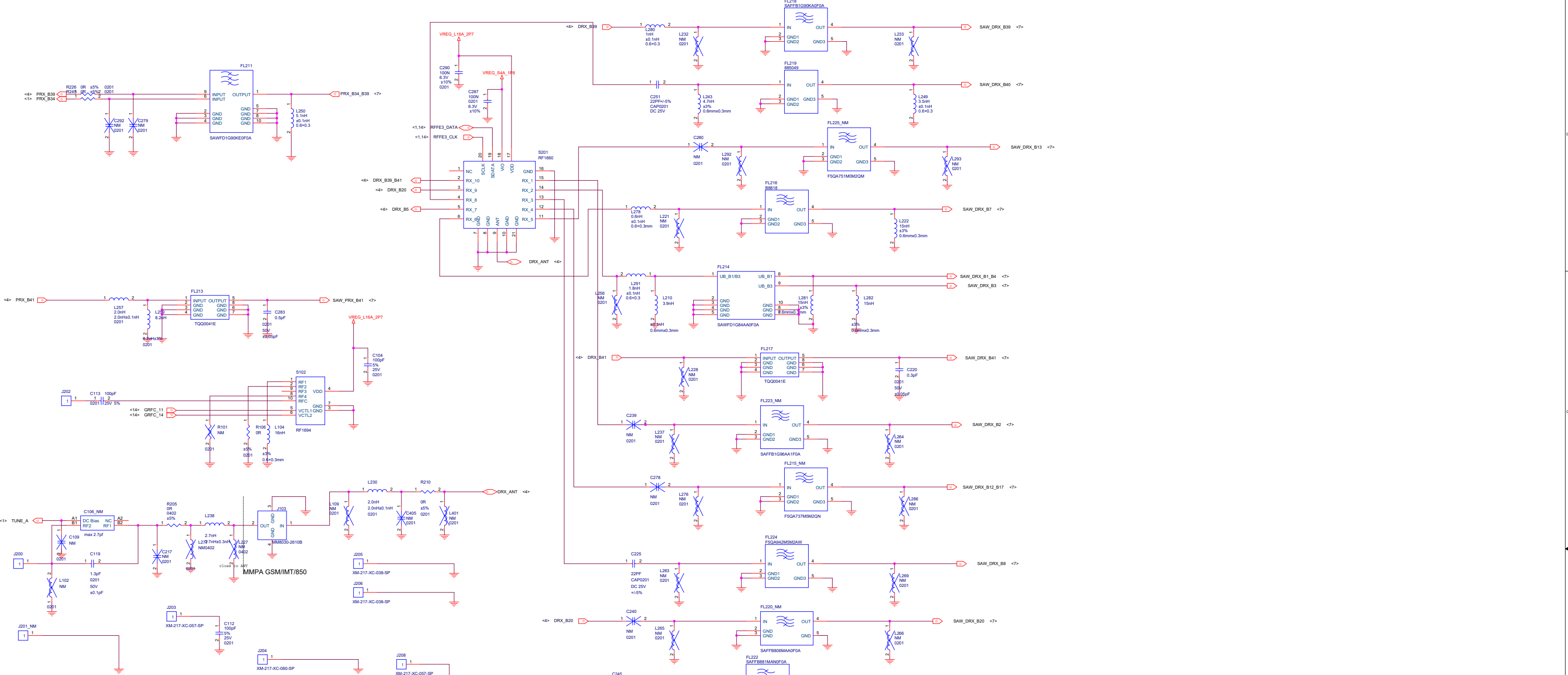

PRx and Drx	SP4T_CTRL_1	SP4T_CTRL_2
B2	H	L
B34	L	L
B1	L	H
B3	H	H

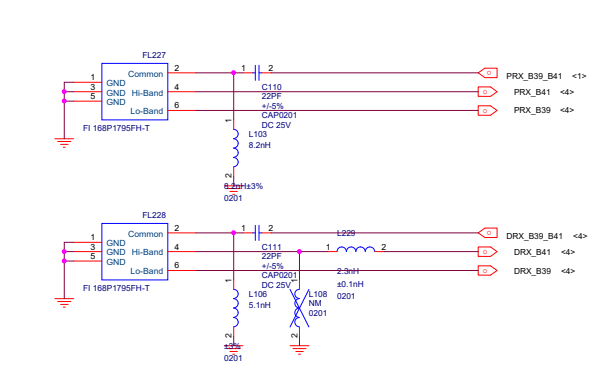

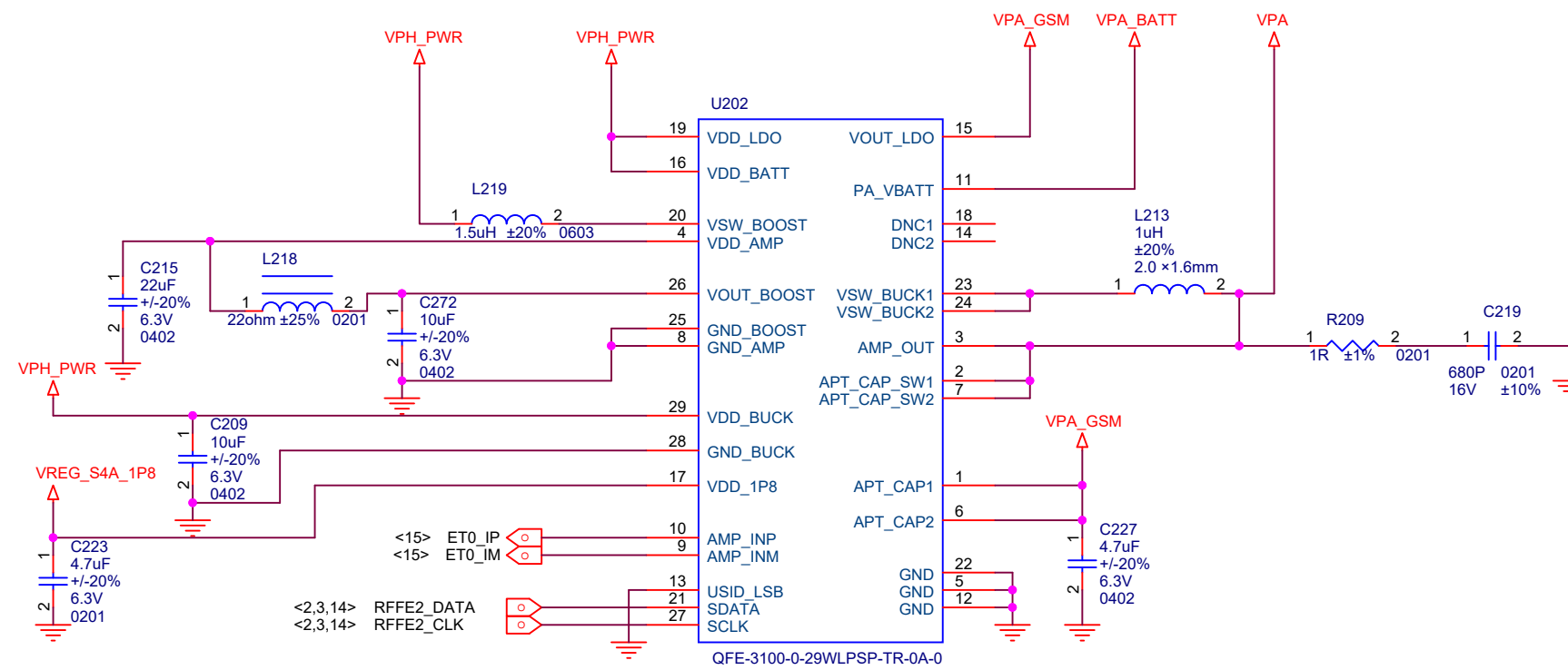

QFE3100

Title		
B7		
Size	Document Number	Rev
A3	QFE3100	P0
Date:	Wednesday, August 17, 2016	Sheet 5 of 35

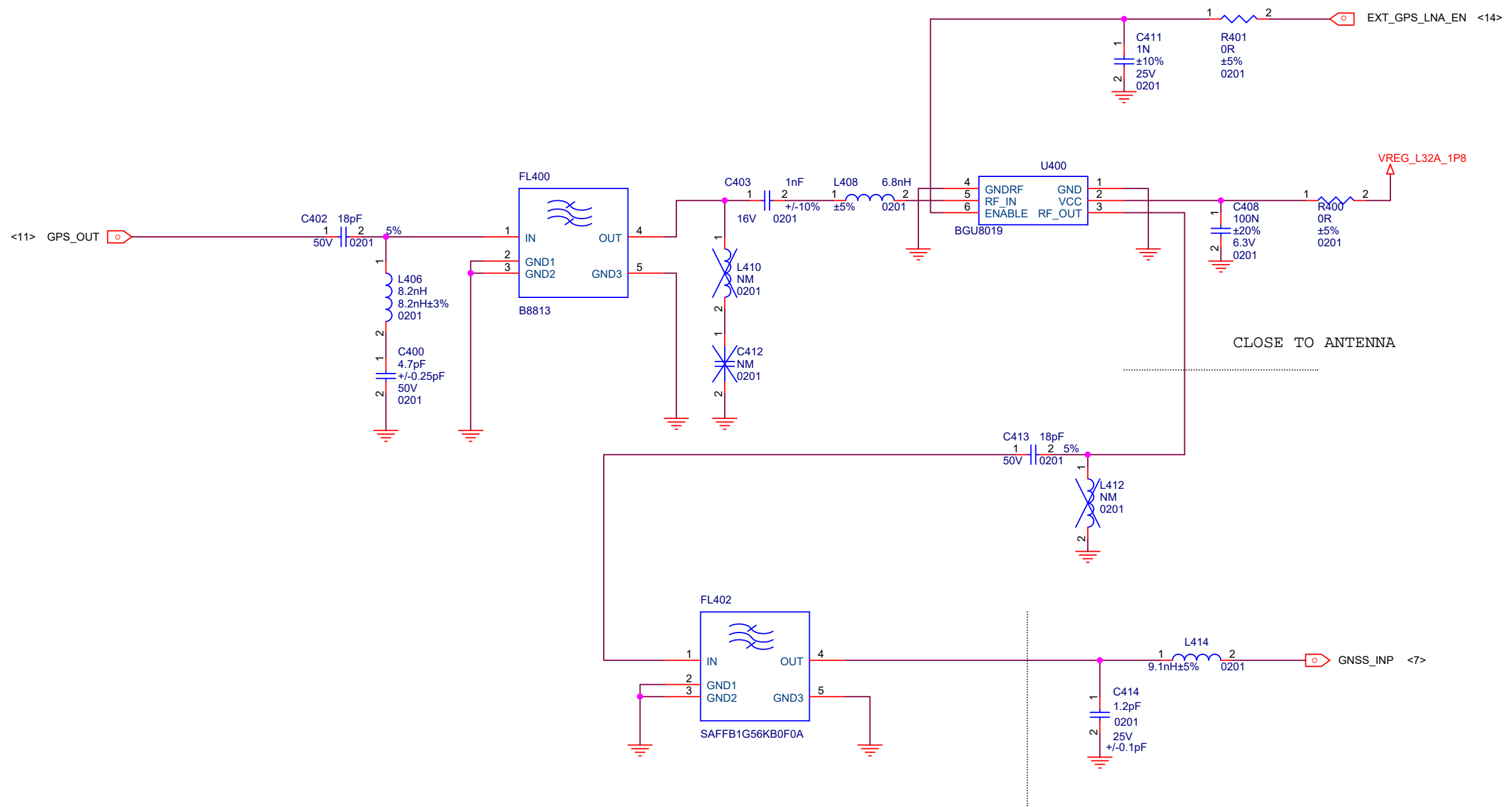

CLOSE TO ANTENNA

GPS		
Title		
B7		
Size	Document Number	Rev
A3	GPS	P0
Date:	Wednesday, August 17, 2016	Sheet 6 of 35

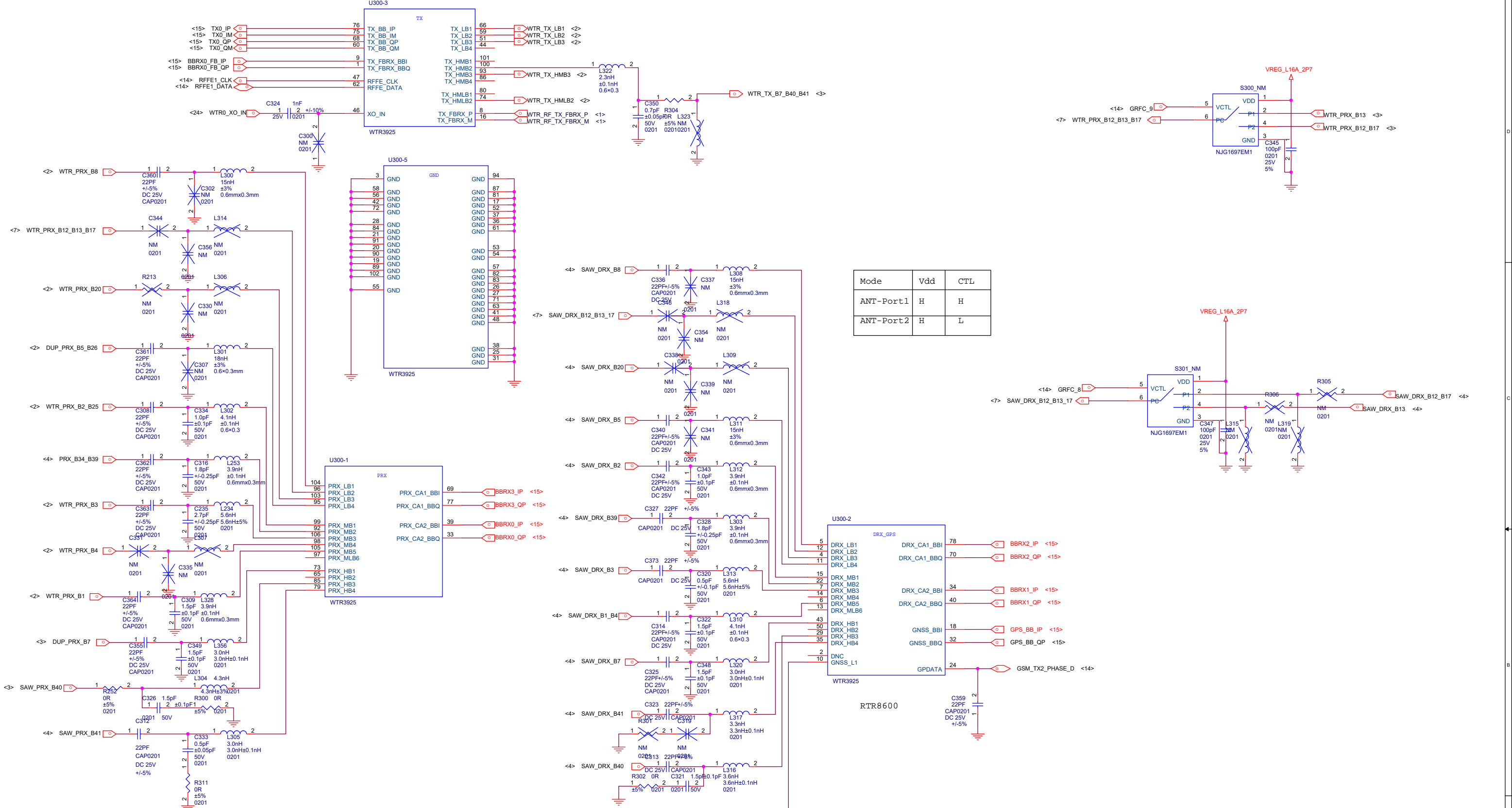

WTR3925L

Title		B7
Size	Document Number	Rev
A2	WTR3925L	PO
Date:	Wednesday, August 17, 2016	Sheet 7 of 35

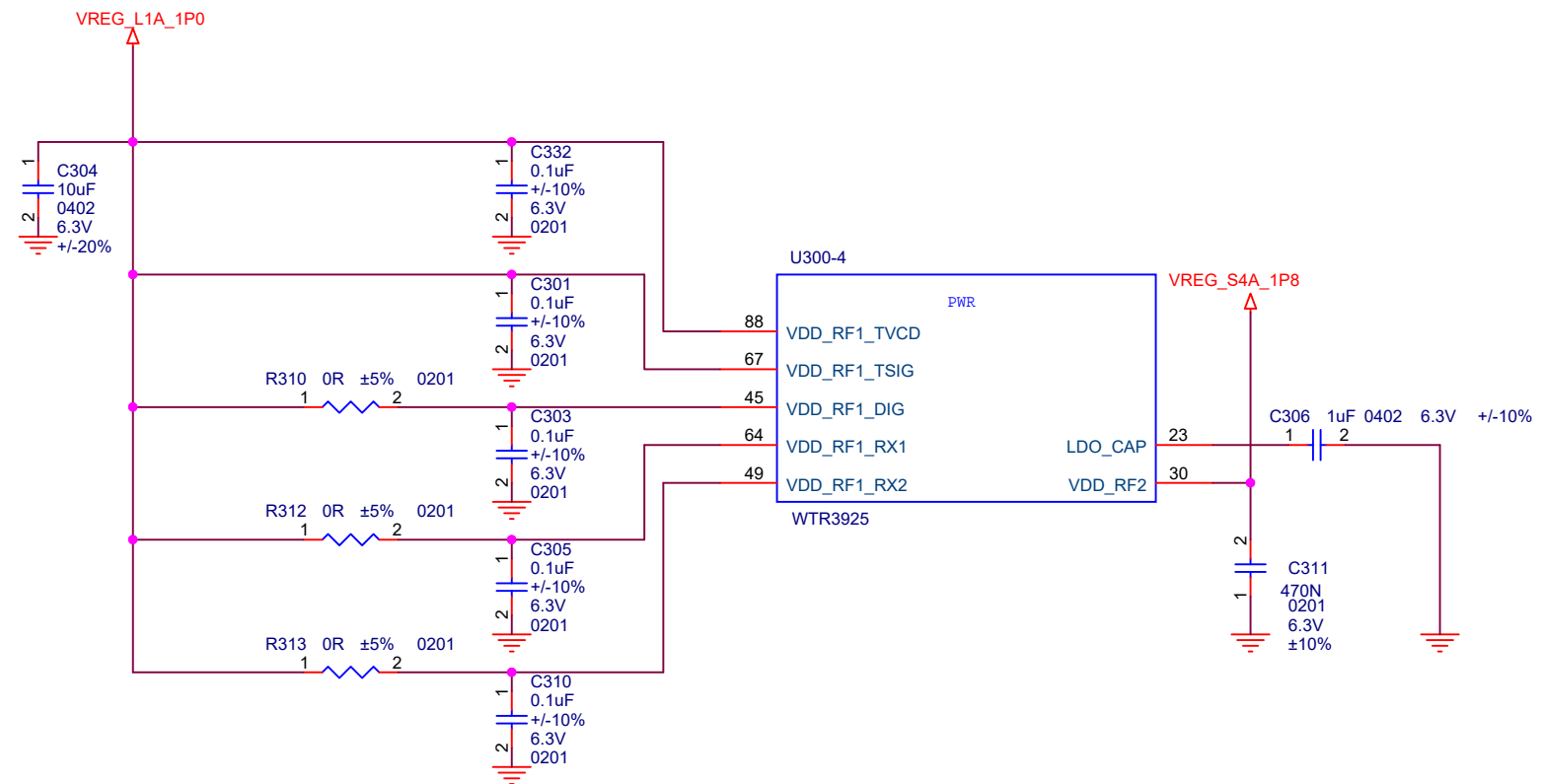

RTR8600 BYPASS

Title		
B7		
Size	Document Number	Rev
A3	WTR3925L BYPASS	P0
Date:	Wednesday, August 17, 2016	Sheet 8 of 35



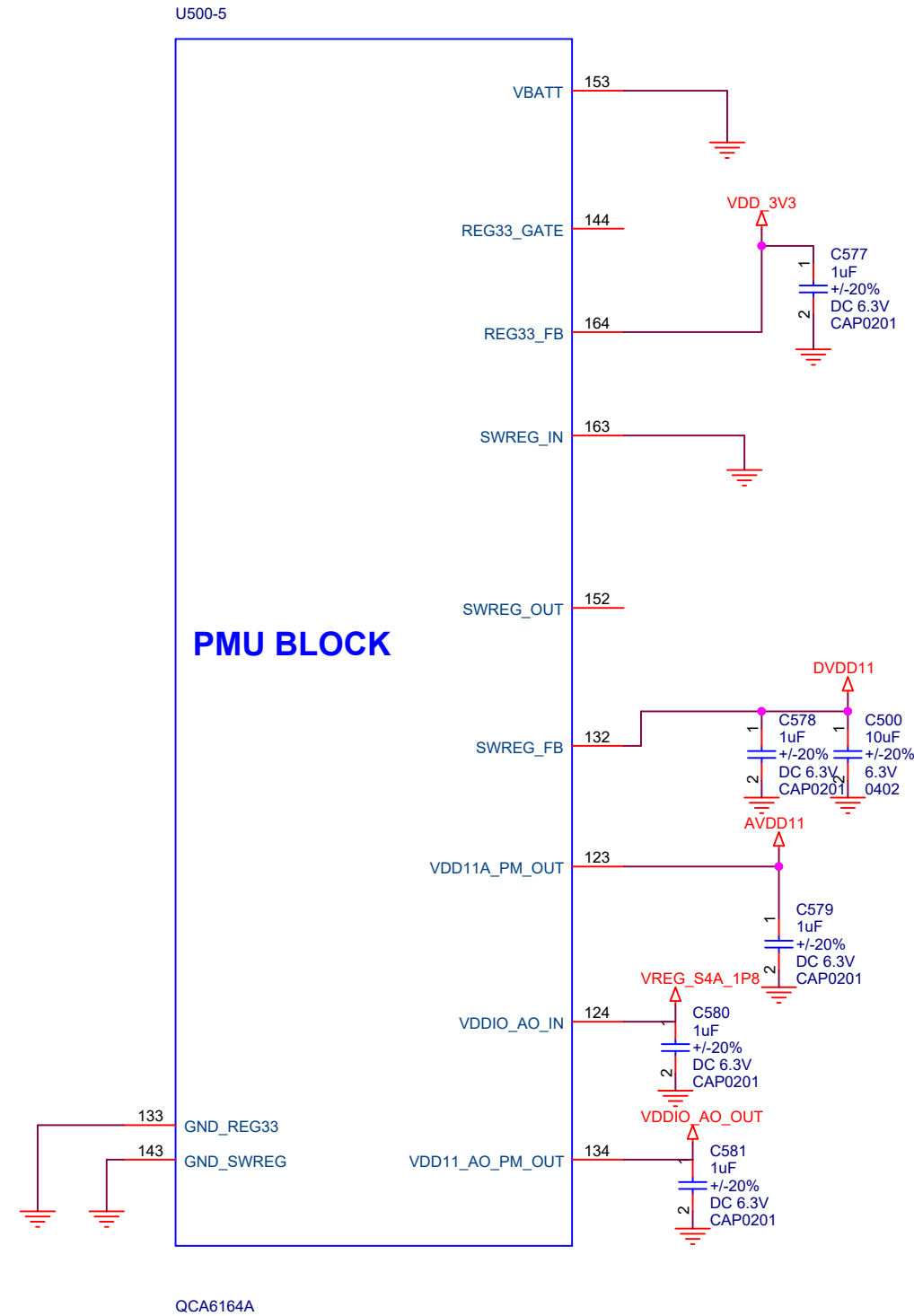
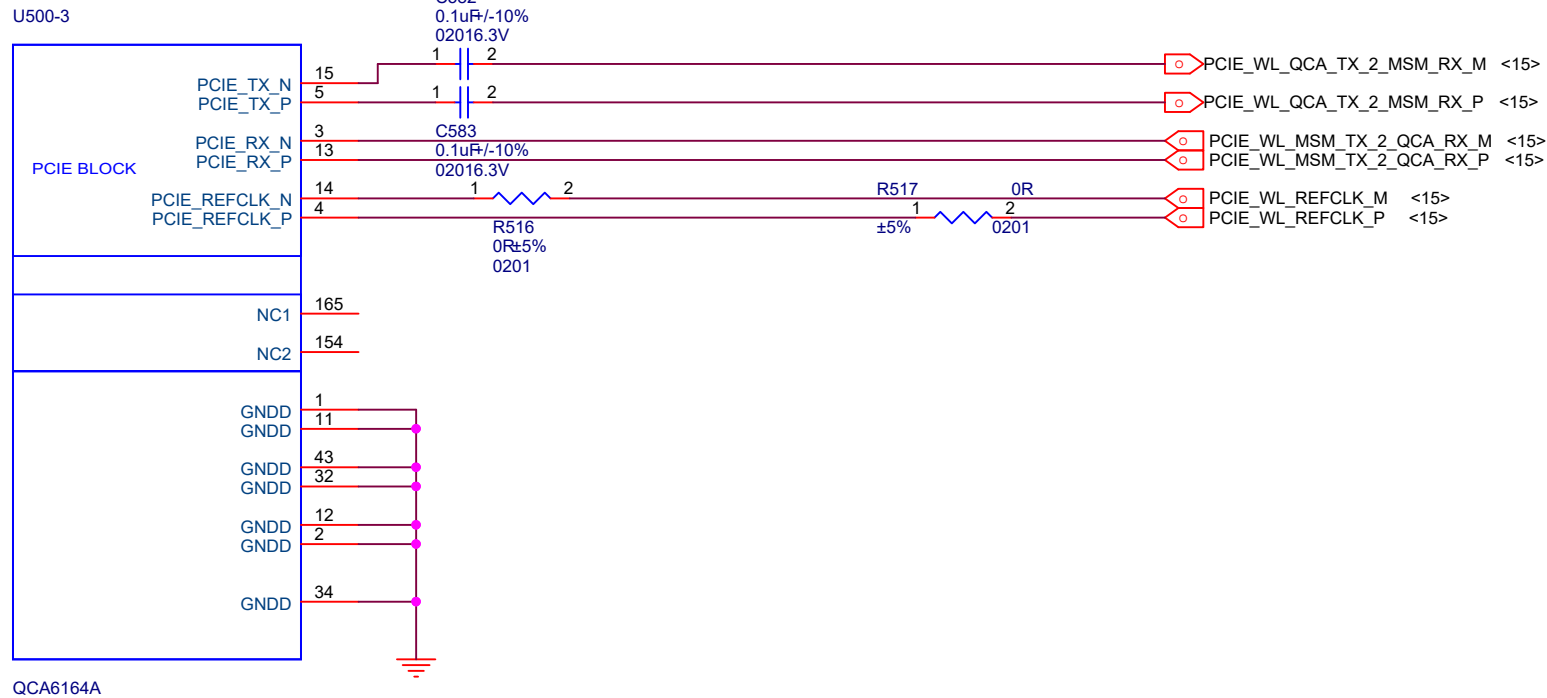
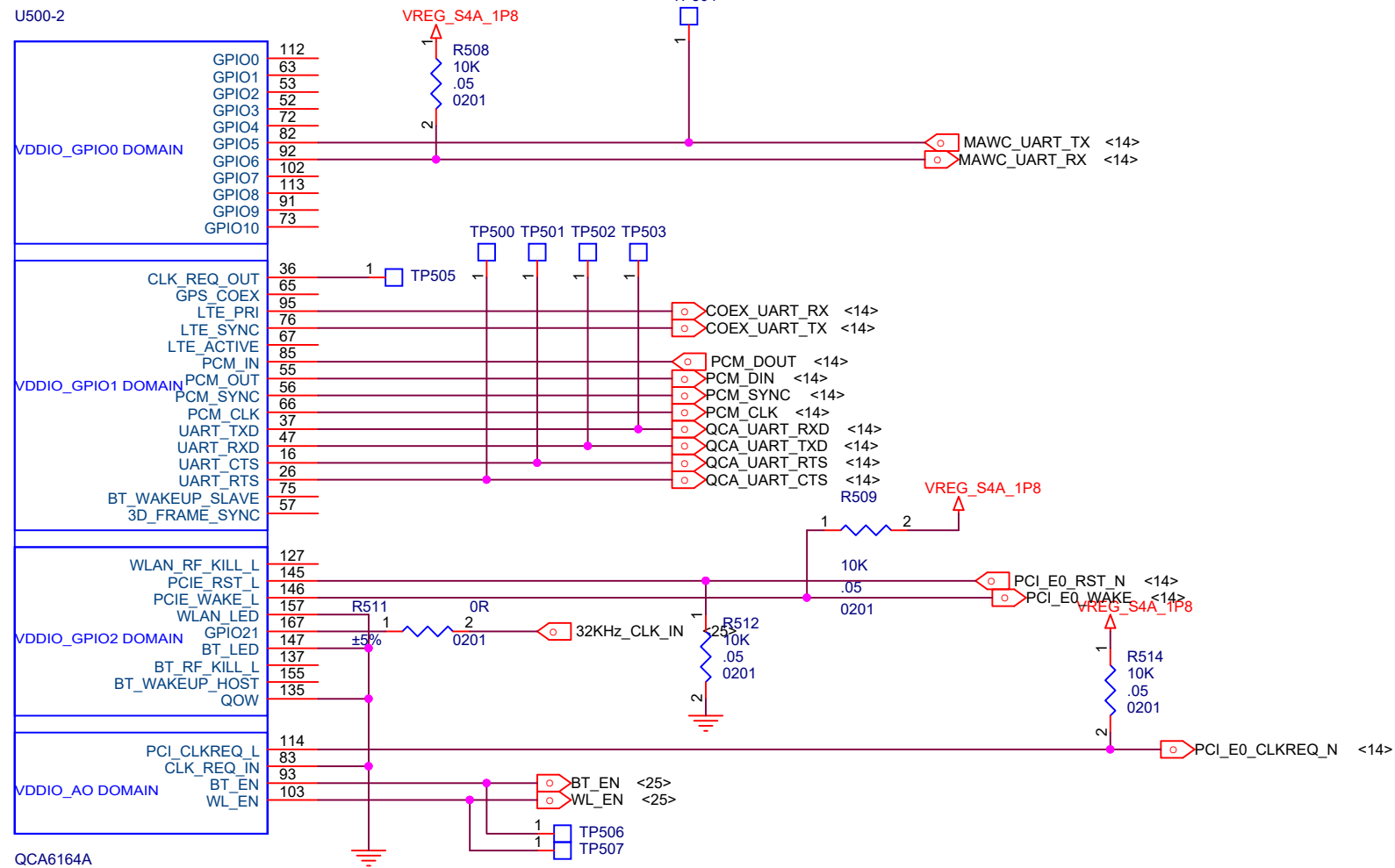

WIFI INTERFACE

Title		
B7		
Size	Document Number	Rev
A3	WIFI INTERFACE	P0
Date:	Wednesday, August 17, 2016	Sheet 9 of 35

# POWER

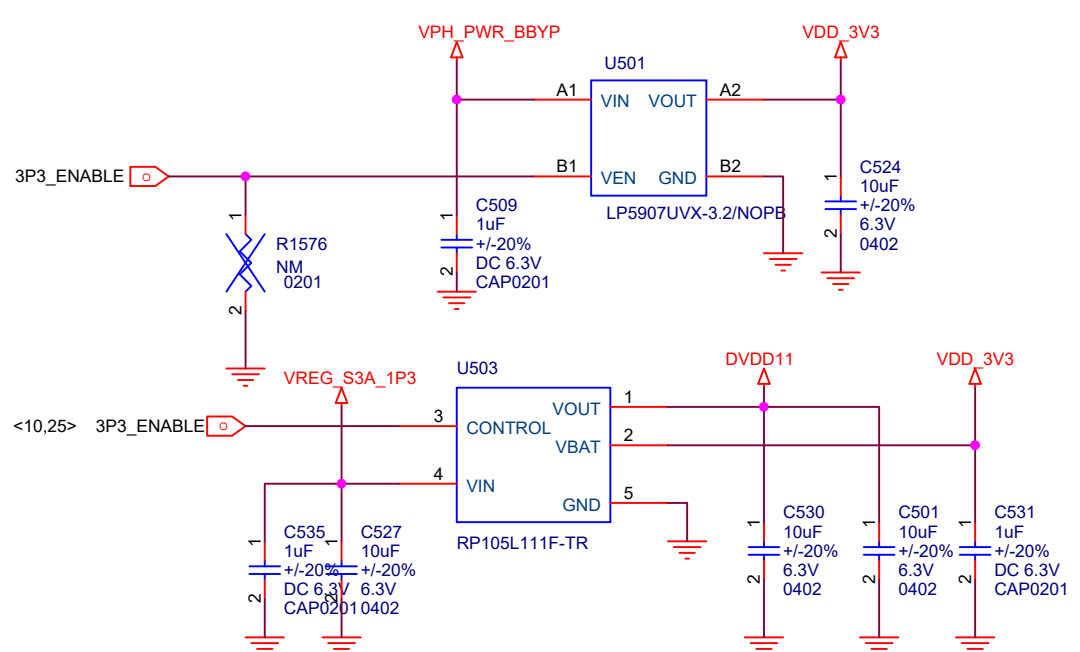
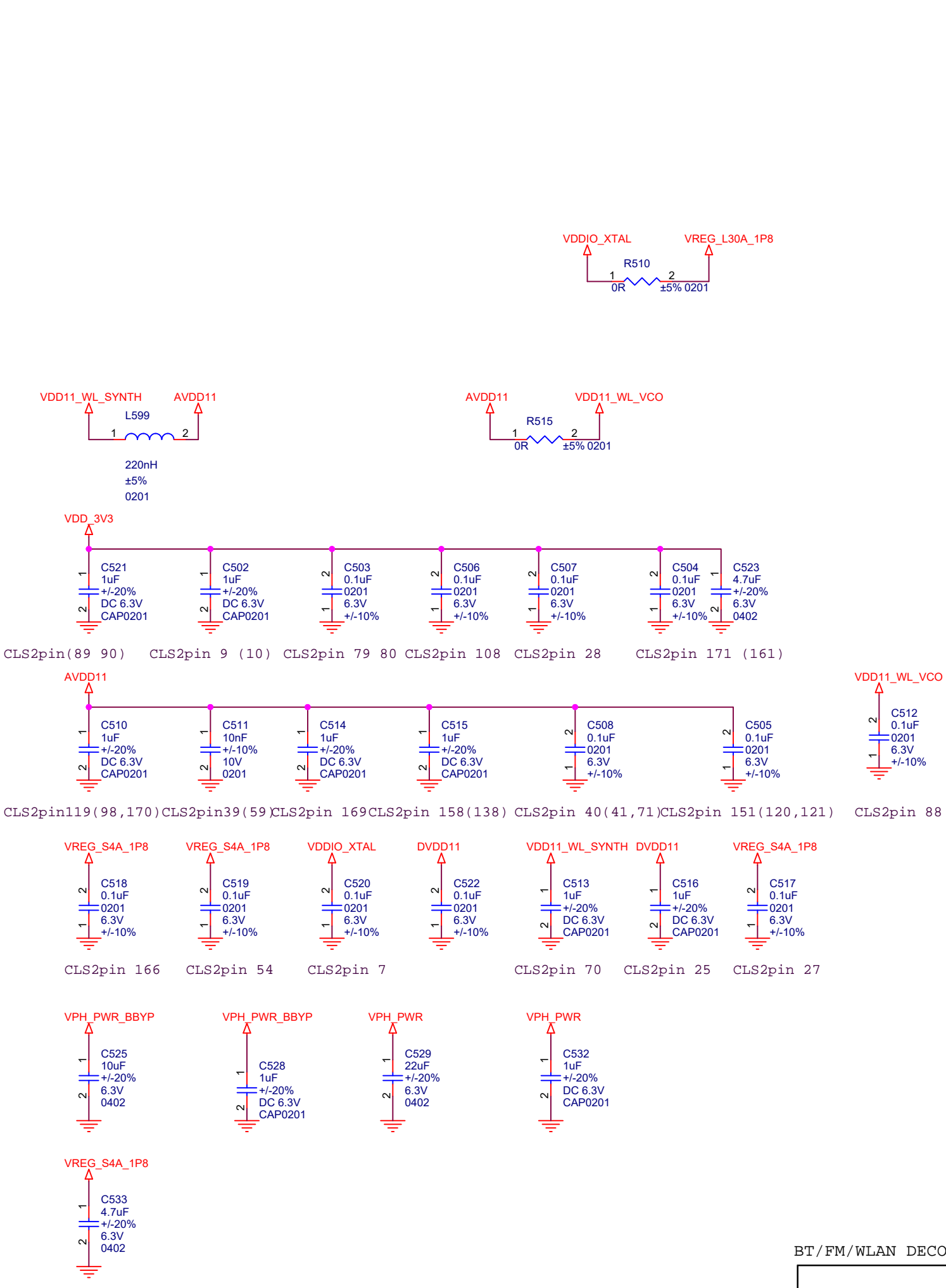
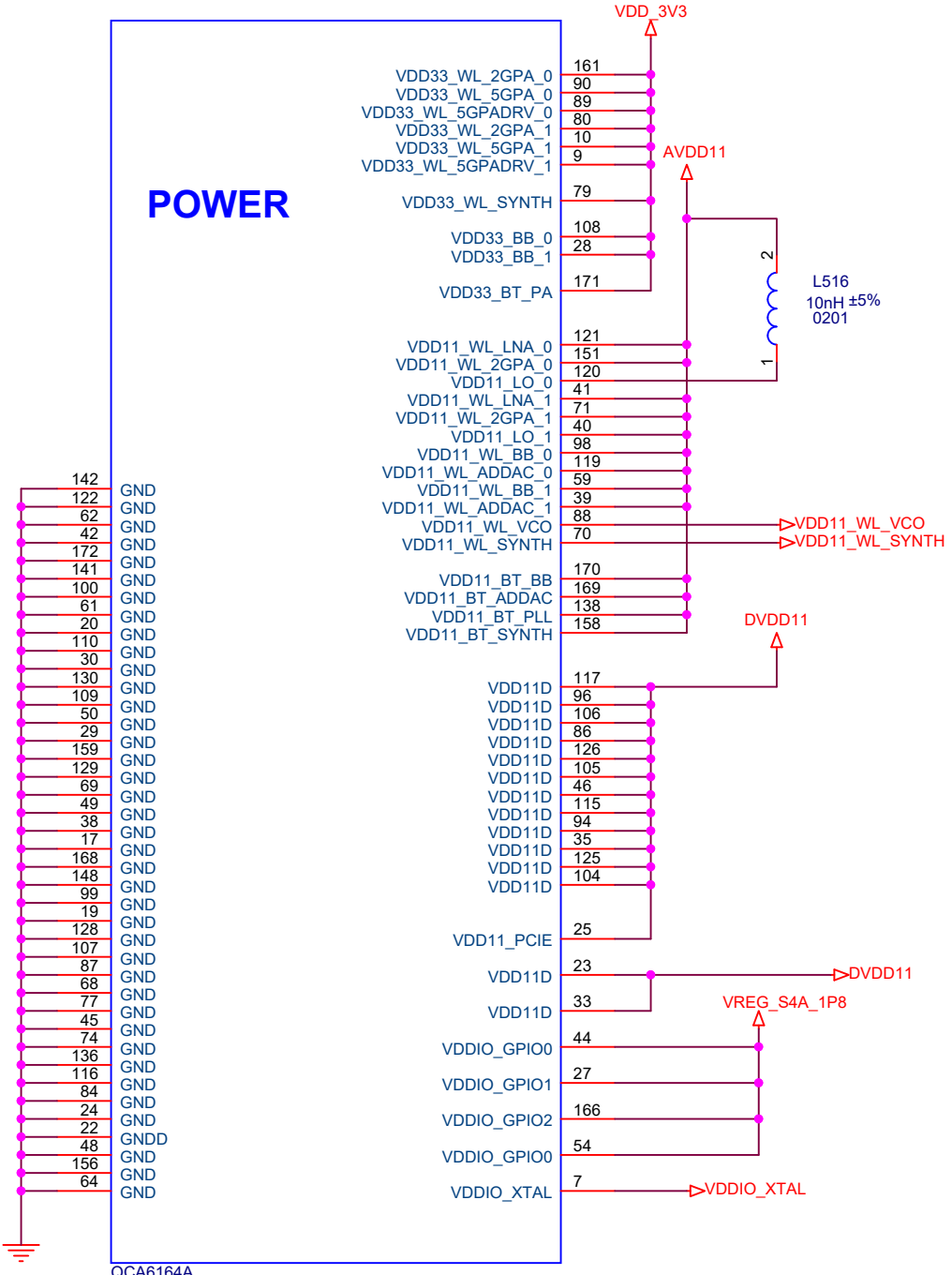

BT/FM/WLAN DECOUP

Title		
B7		
Size	Document Number	Rev
A3	BT/WLAN DECOUP	P0
Date:	Wednesday, August 17, 2016	Sheet 10 of 35

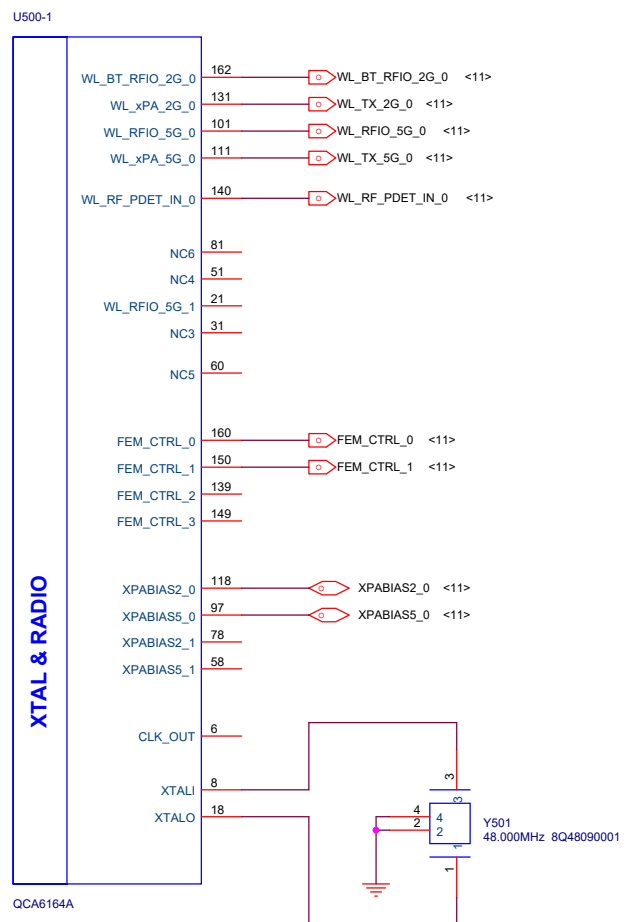
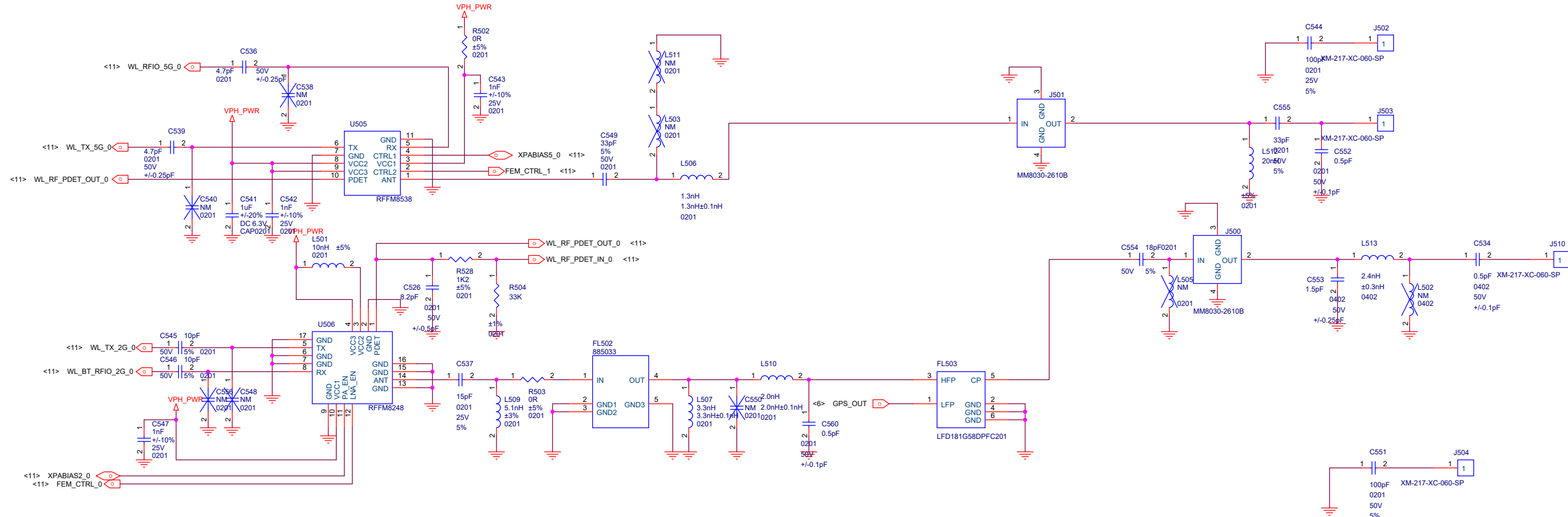

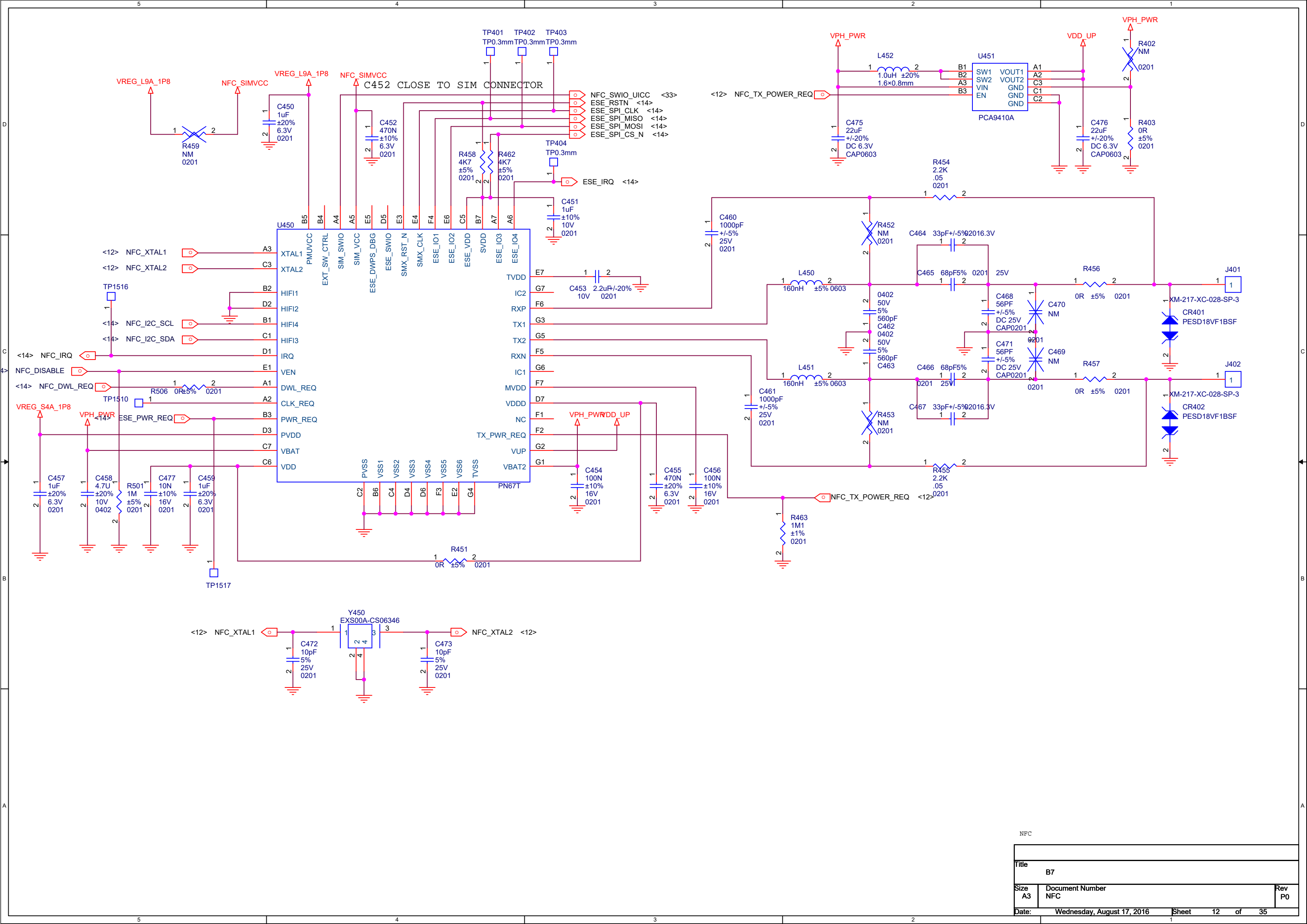

Title		
B7		
Size	Document Number	Rev
A3	NFC	P0
Date:	Wednesday, August 17, 2016	Sheet 12 of 35

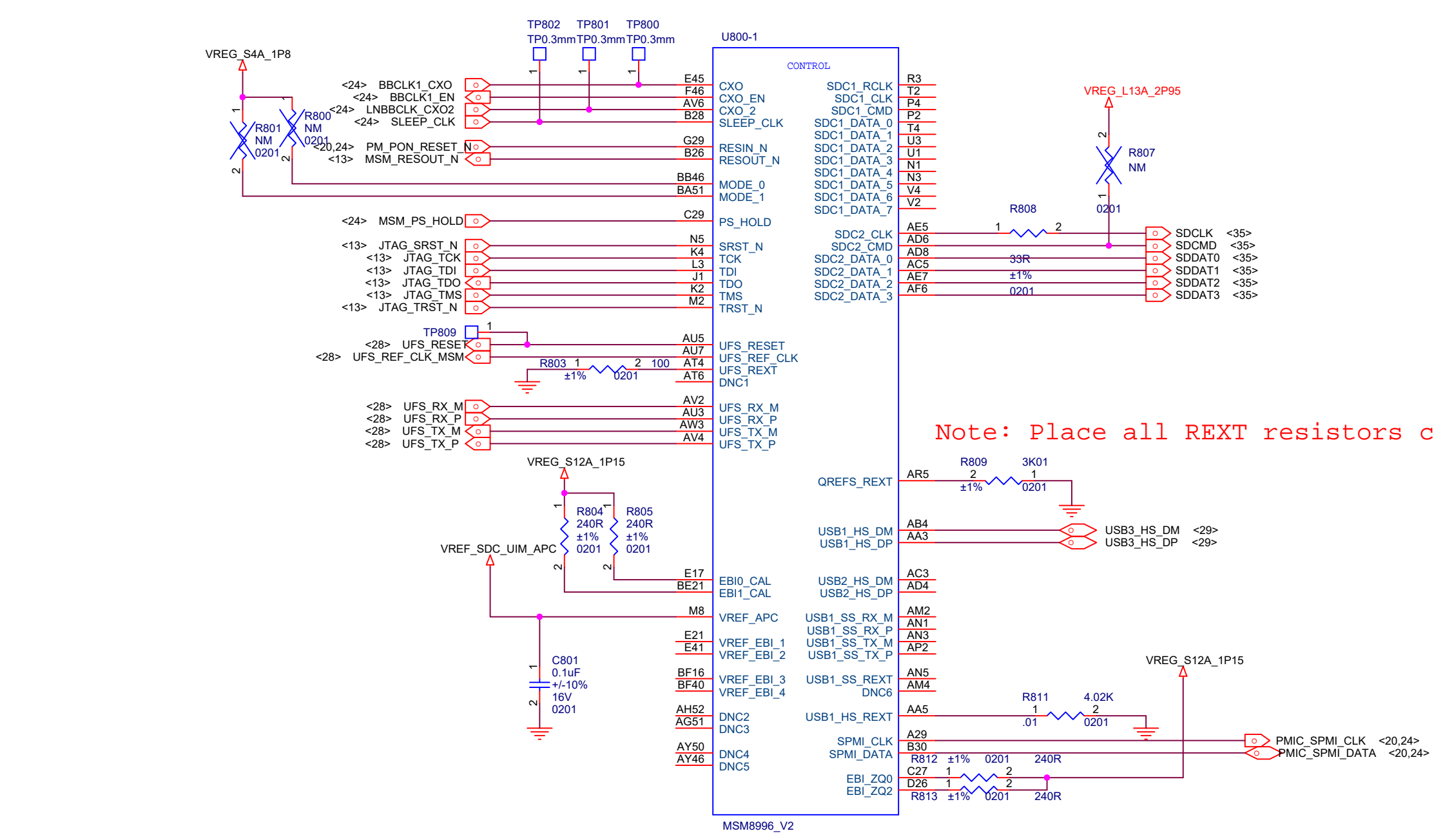

Note: Place all REXT resistors close to MSM

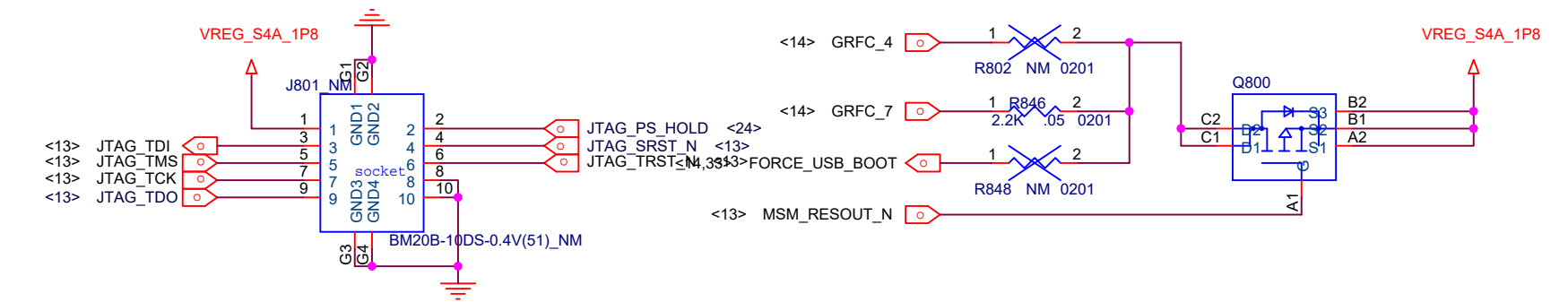

MSM8996 CONTROL

Title		
B7		
Size	Document Number	Rev
A3	MSM8996 CONTROL	P0
Date:	Wednesday, August 17, 2016	Sheet 13 of 35

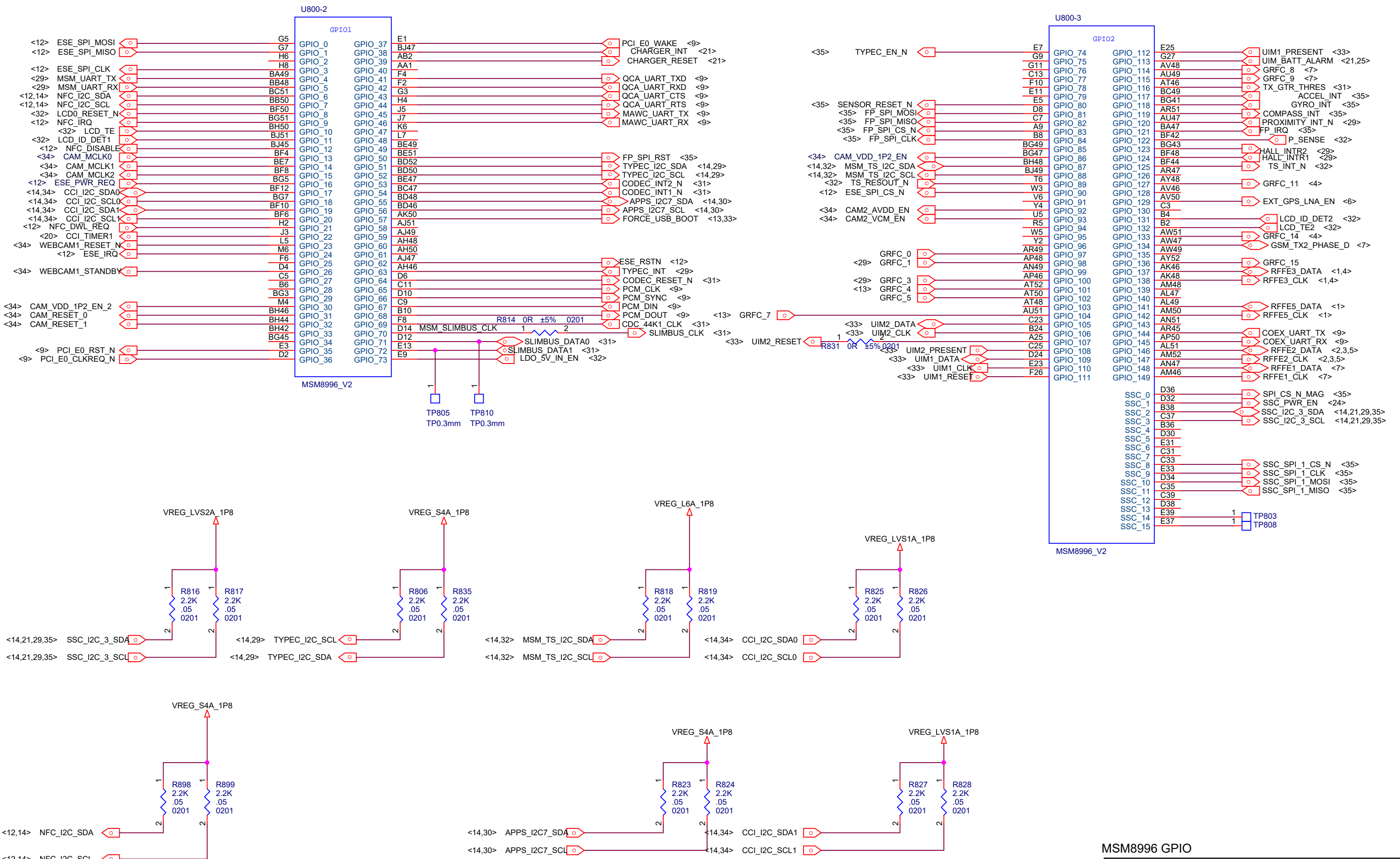

MSM8996 GPIO		
Title B7		
Size A3	Document Number MSM8996 GPIO	Rev P0
Date:	Wednesday, August 17, 2016	Sheet 14 of 35



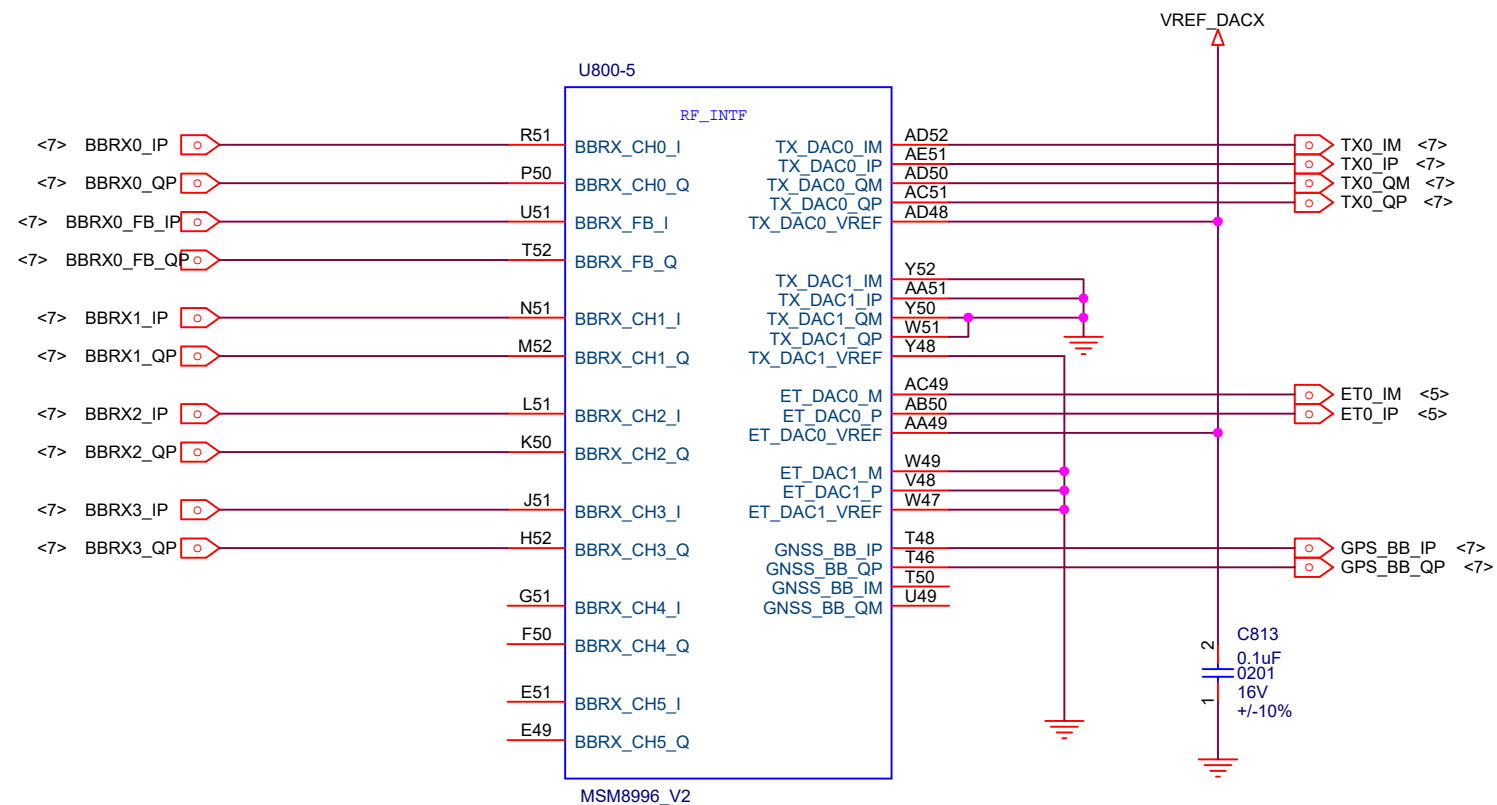
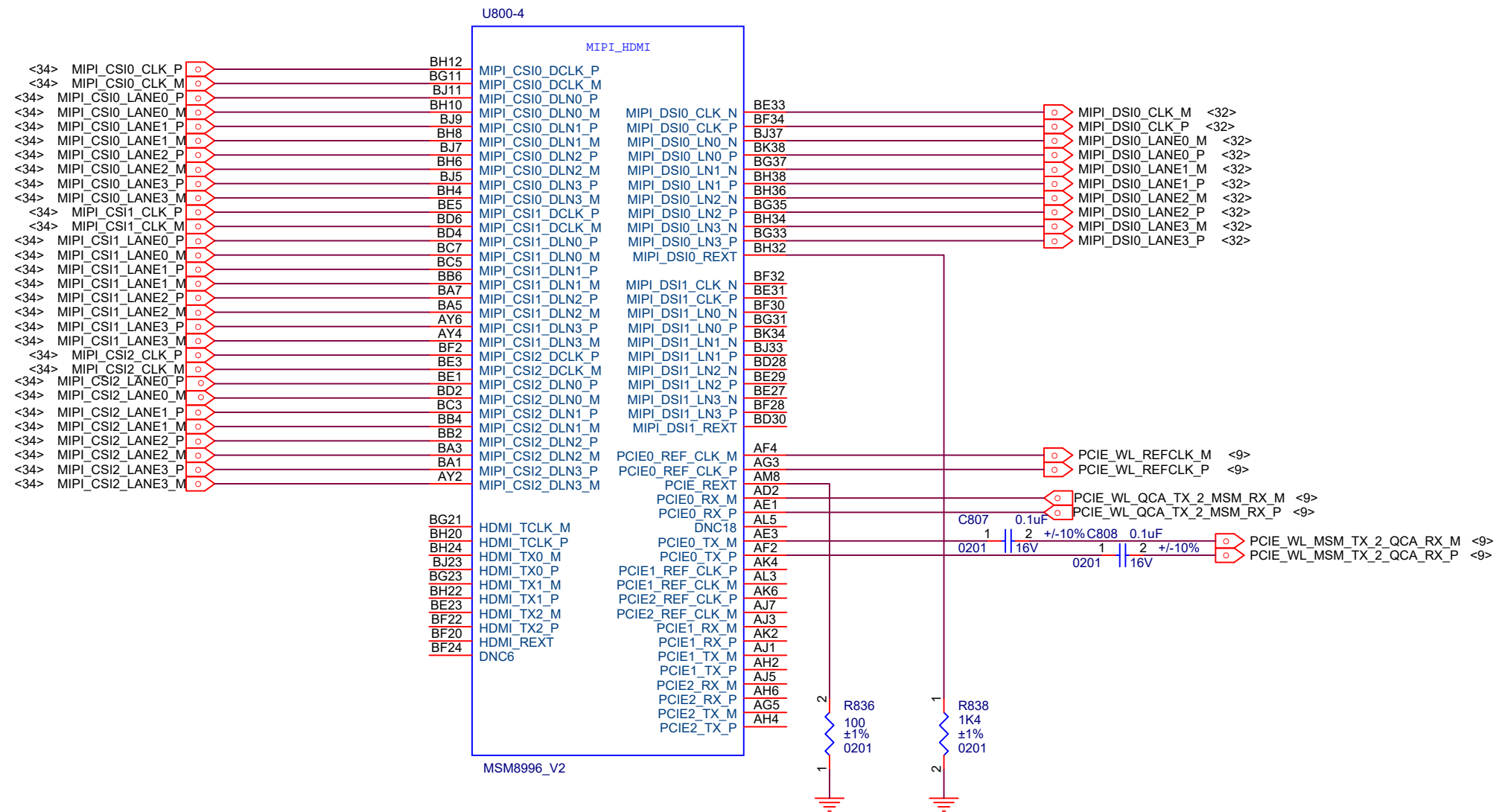

**MSM8996 MIPI**

Title		
B7		
Size	Document Number	Rev
A3	MSM8996 MIPI	P0
Date:	Wednesday, August 17, 2016	Sheet 15 of 35

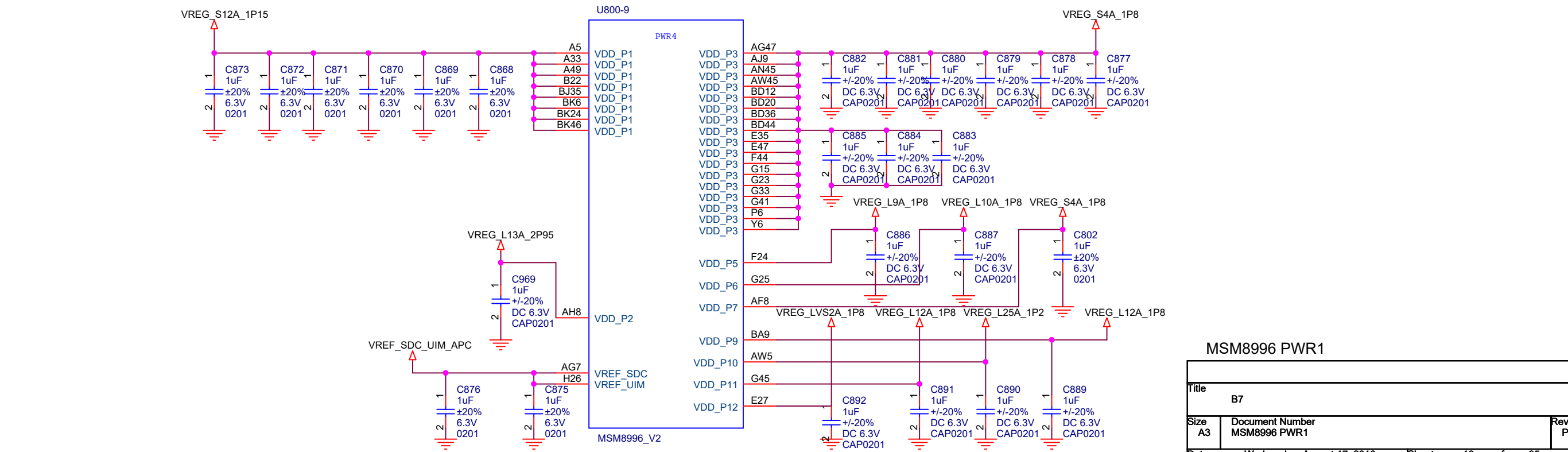
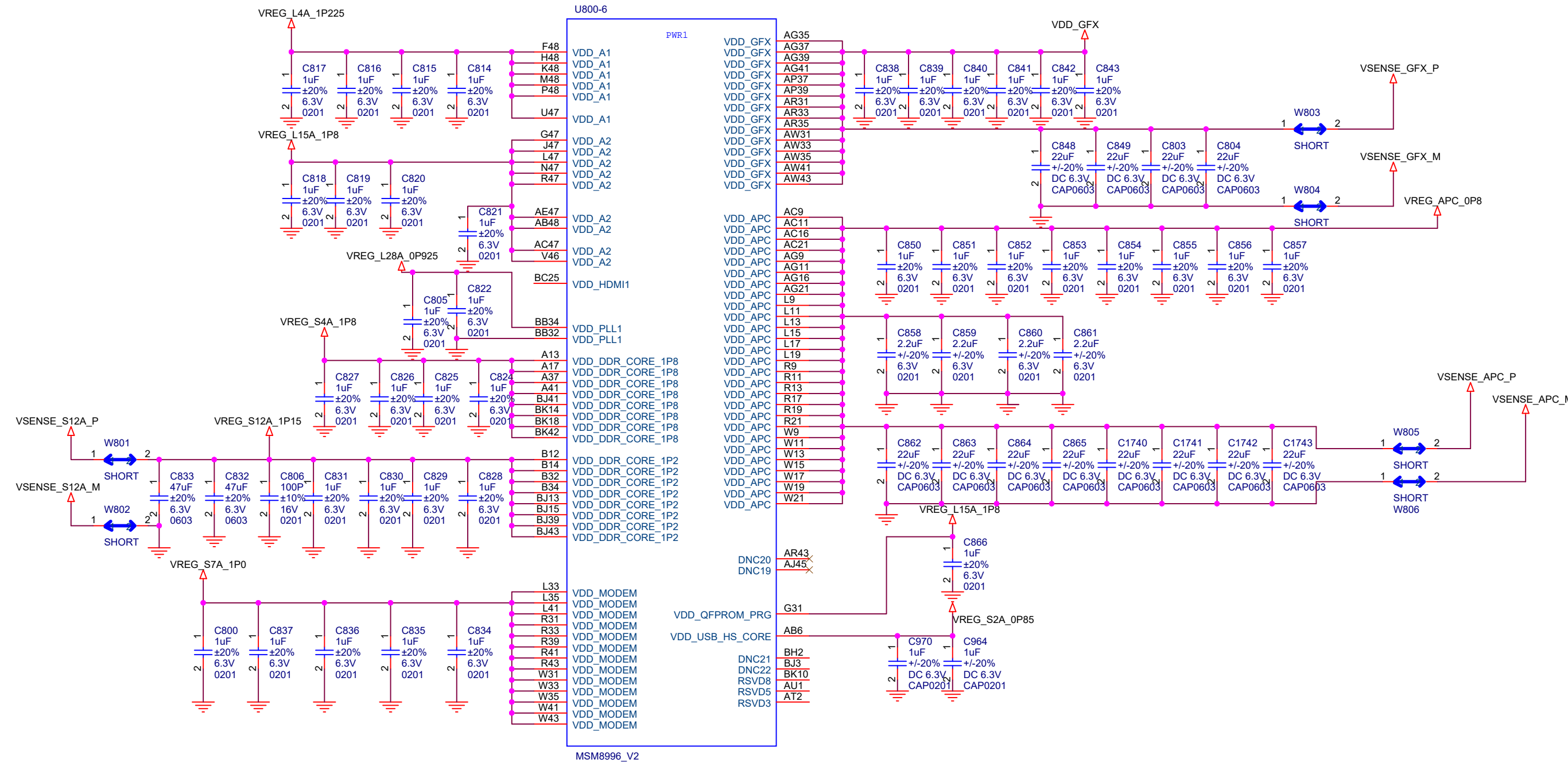

**MSM8996 PWR1**

Title			B7		
Size	Document Number		Rev		
A3	MSM8996 PWR1		P0		
Date:	Wednesday, August 17, 2016	Sheet	16	of	35



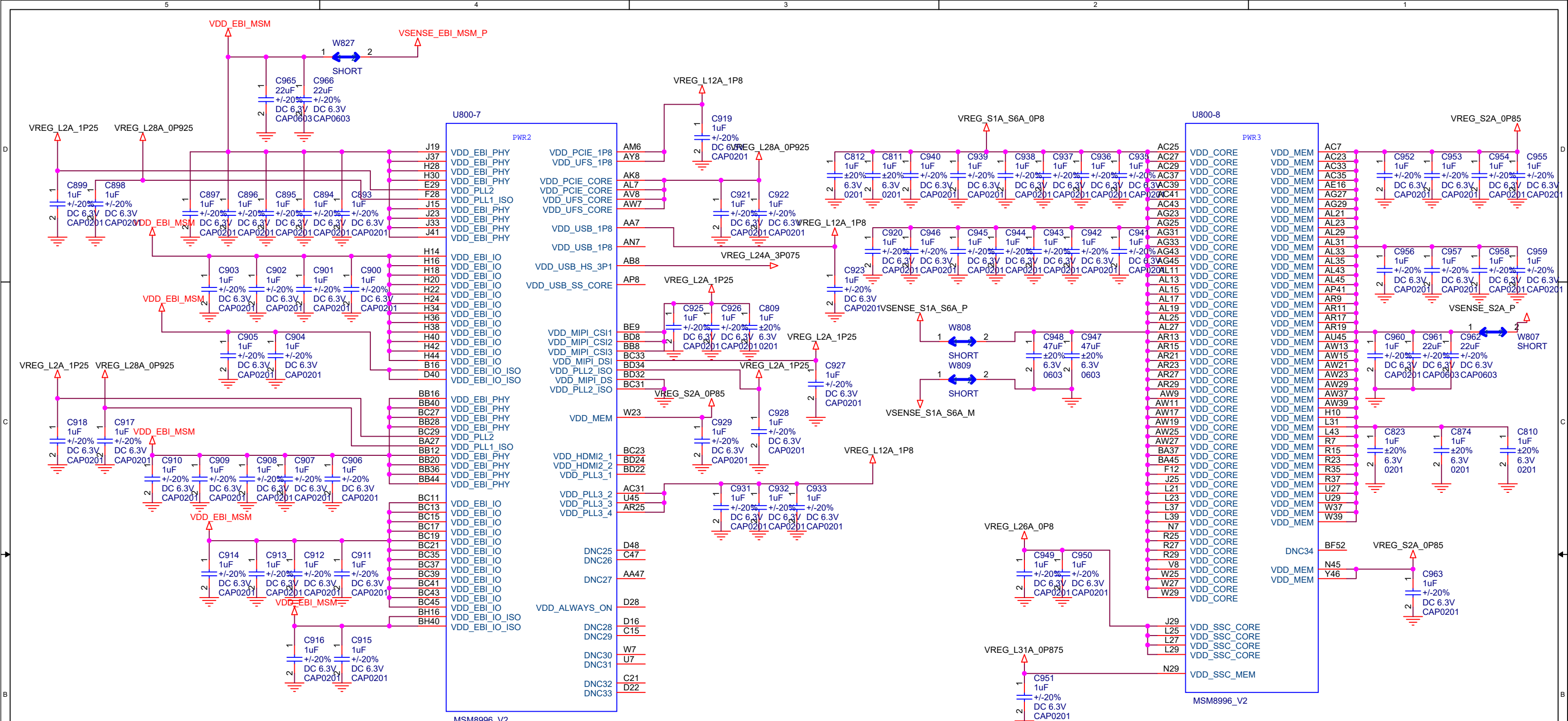

MSM8996 PWR2

Title			B7
Size	Document Number	Rev	
A3	MSM 8996 PWR2	P0	
Date:	Wednesday, August 17, 2016	Sheet	17 of 35

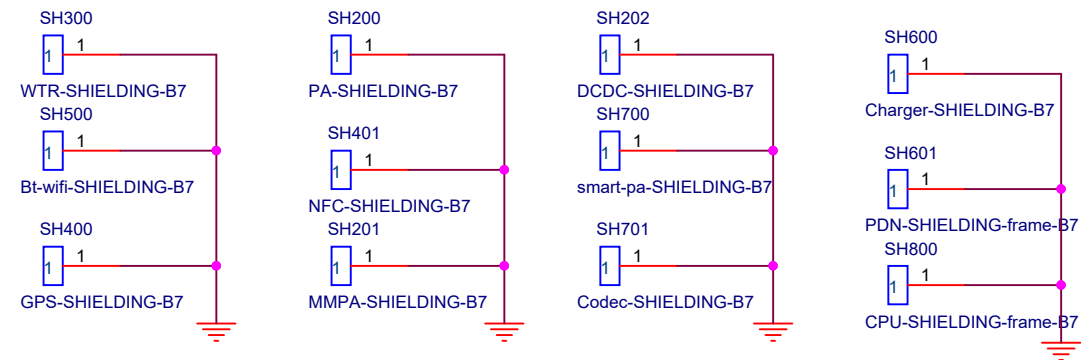
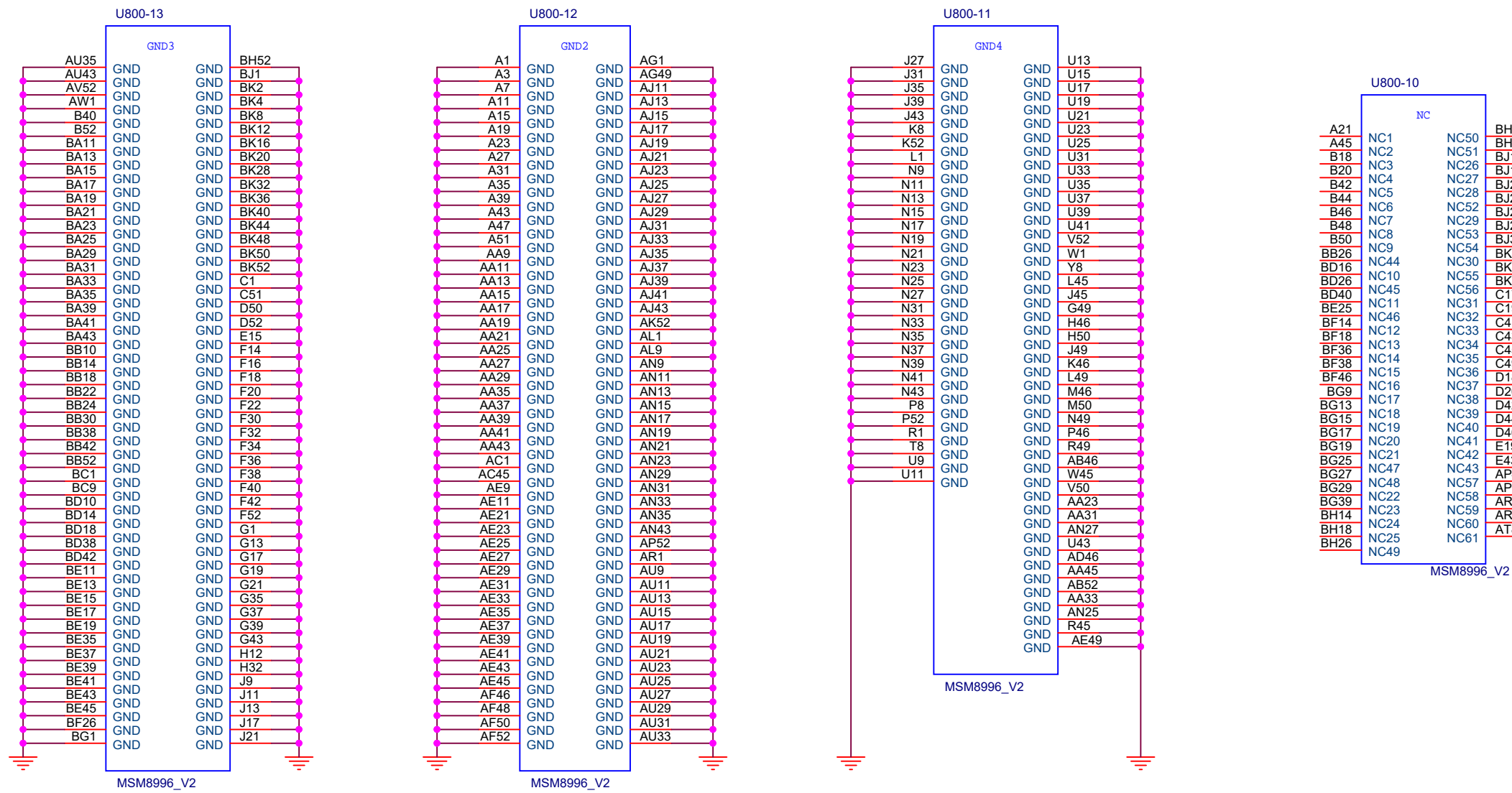

MSM8996 GND

Title		
B7		
Size	Document Number	Rev
A3	MSM8996 GND	P0
Date:	Wednesday, August 17, 2016	Sheet 18 of 35

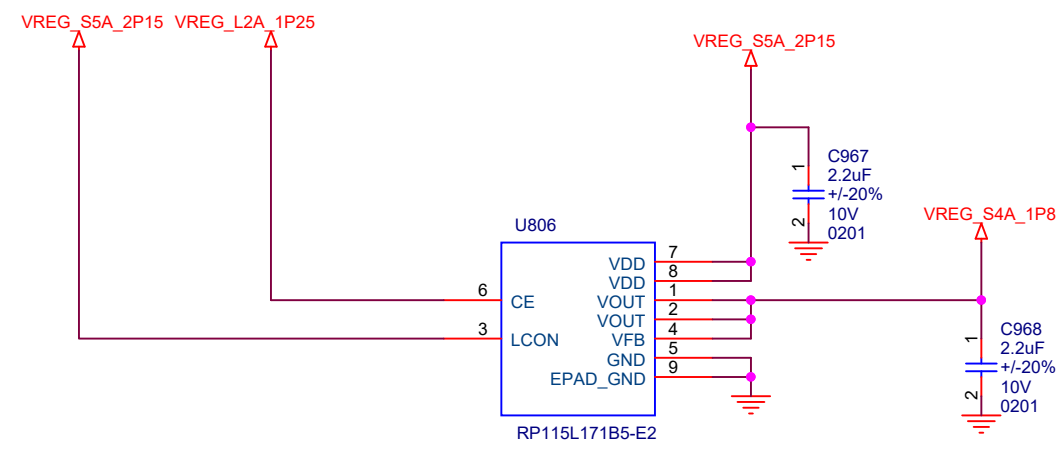

MSM8996 LPDDR REGULATOR

Title		
B7		
Size	Document Number	Rev
A3	MSM8996 LPDDR REGULATOR	P0
Date:	Wednesday, August 17, 2016	Sheet 19 of 35

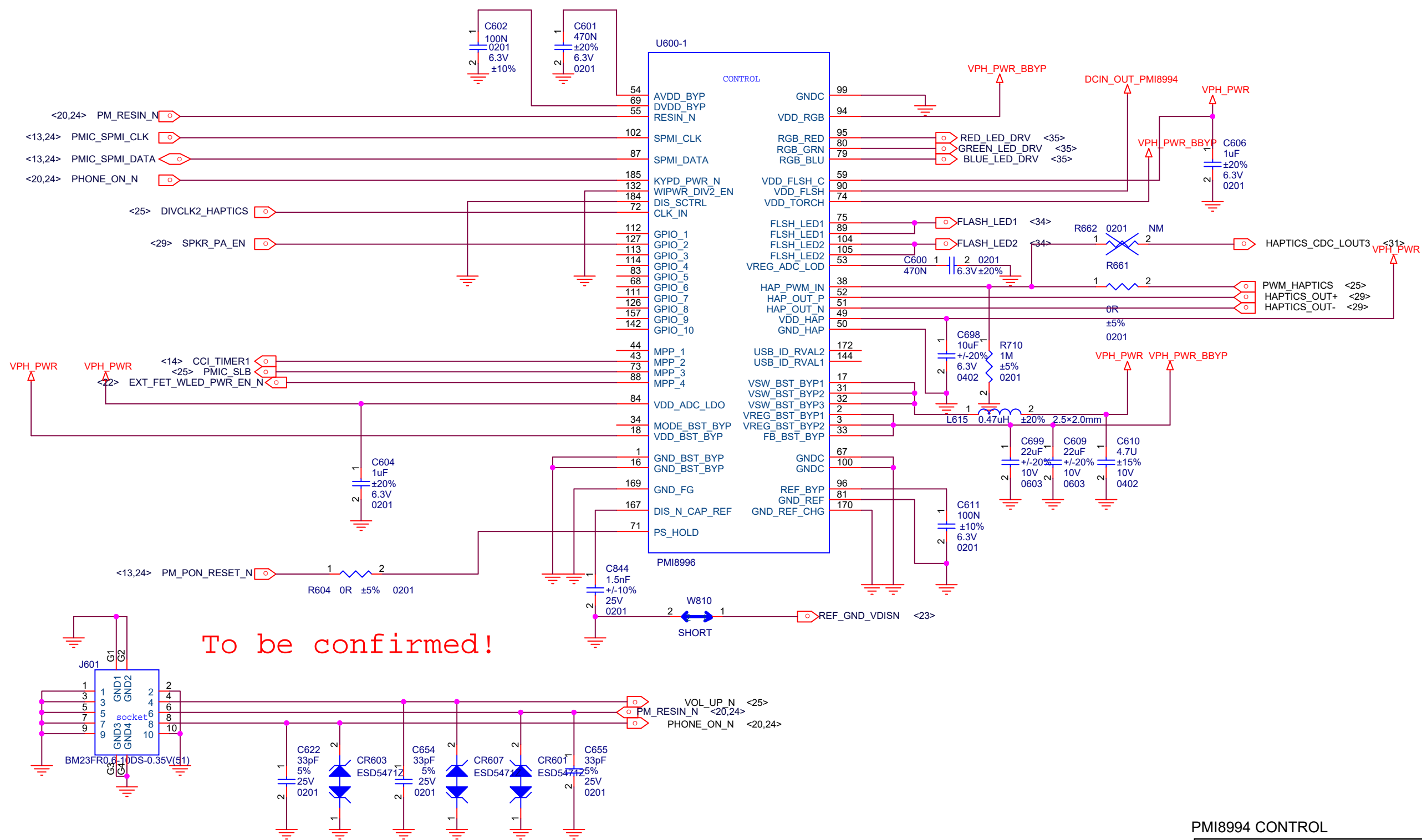

**PMI8996 CONTROL**

Title		
B7		
Size	Document Number	Rev
A3	PMI8996 CONTROL	P0
Date:	Wednesday, August 17, 2016	Sheet 20 of 35

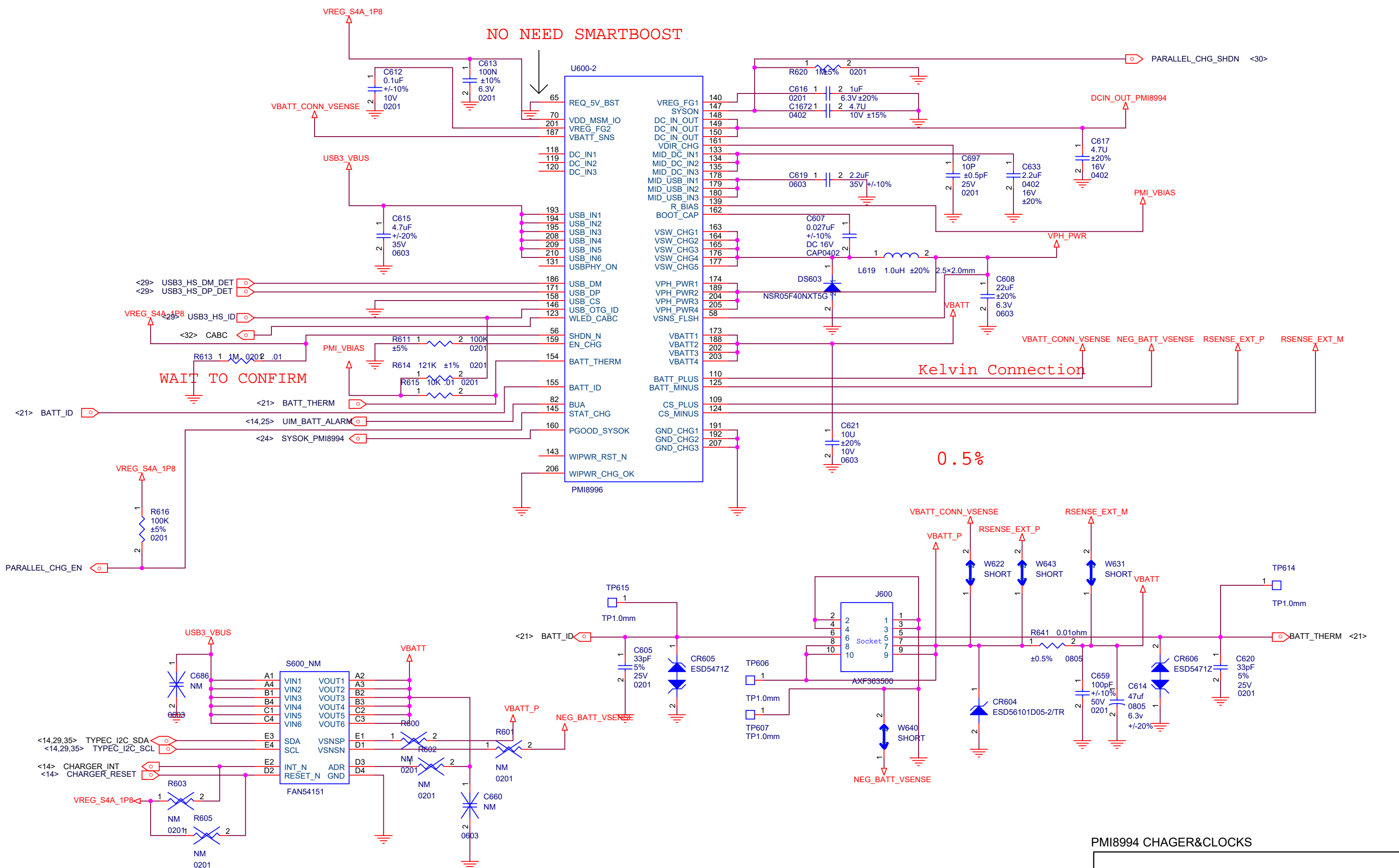

**PM18996 CHARGER&CLOCKS**

Title		
B7		
Size	Document Number	Rev
A3	PM18996 CHARGE&cCLOCKS	P0
Date:	Wednesday, August 17, 2016	Sheet 21 of 35

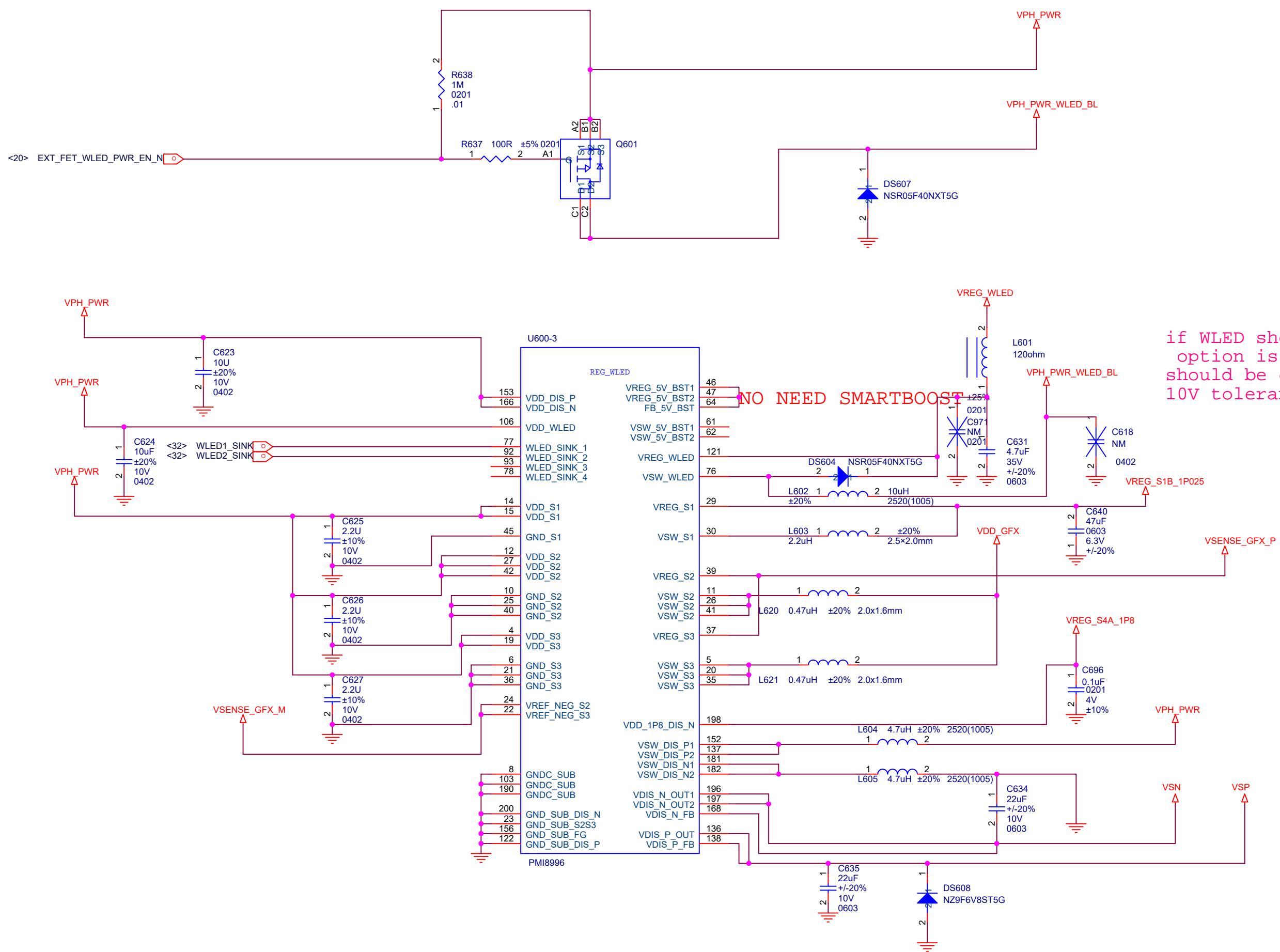

if WLED short circuit protection option is not used, C1670 should be changed to 10uF, 10V tolerance capacitor

PMI8994 REG WLED

Title		
B7		
Size	Document Number	Rev
A3	PMI8996 REG_WLED	P0
Date:	Wednesday, August 17, 2016	Sheet 22 of 35

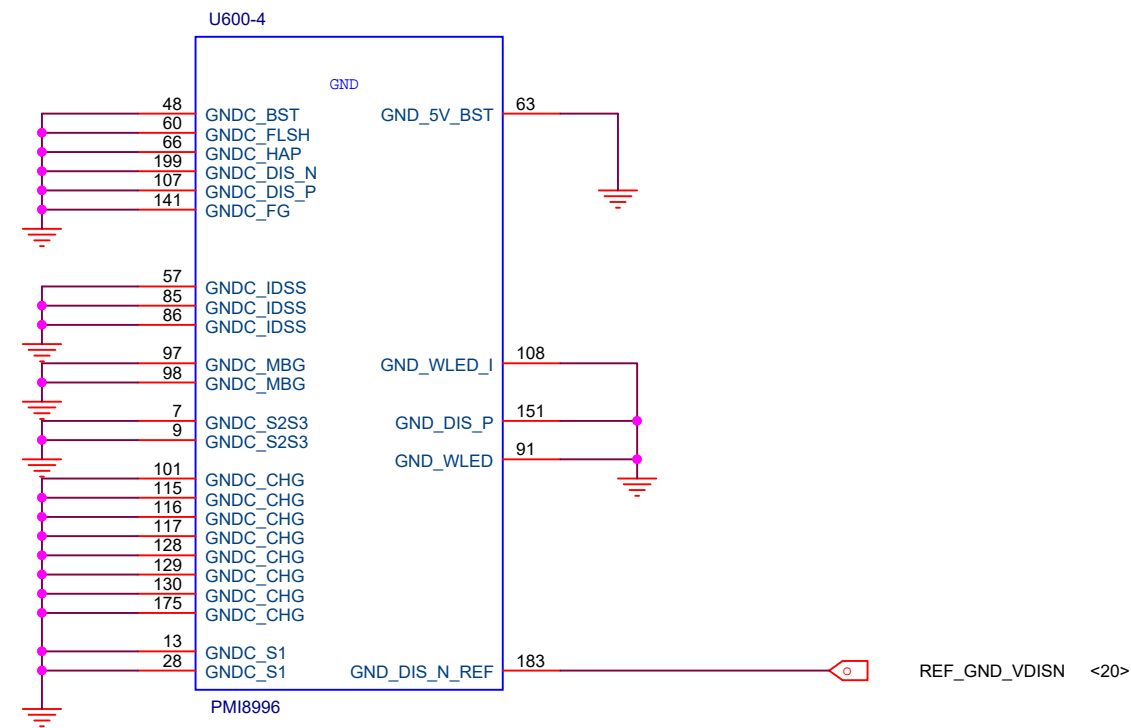

CAD NOTE: Connect to pin183 then GND with single via

PMI8994 GND

Title		
B7		
Size	Document Number	Rev
A3	PMI8996 GND	P0
Date:	Wednesday, August 17, 2016	Sheet 23 of 35

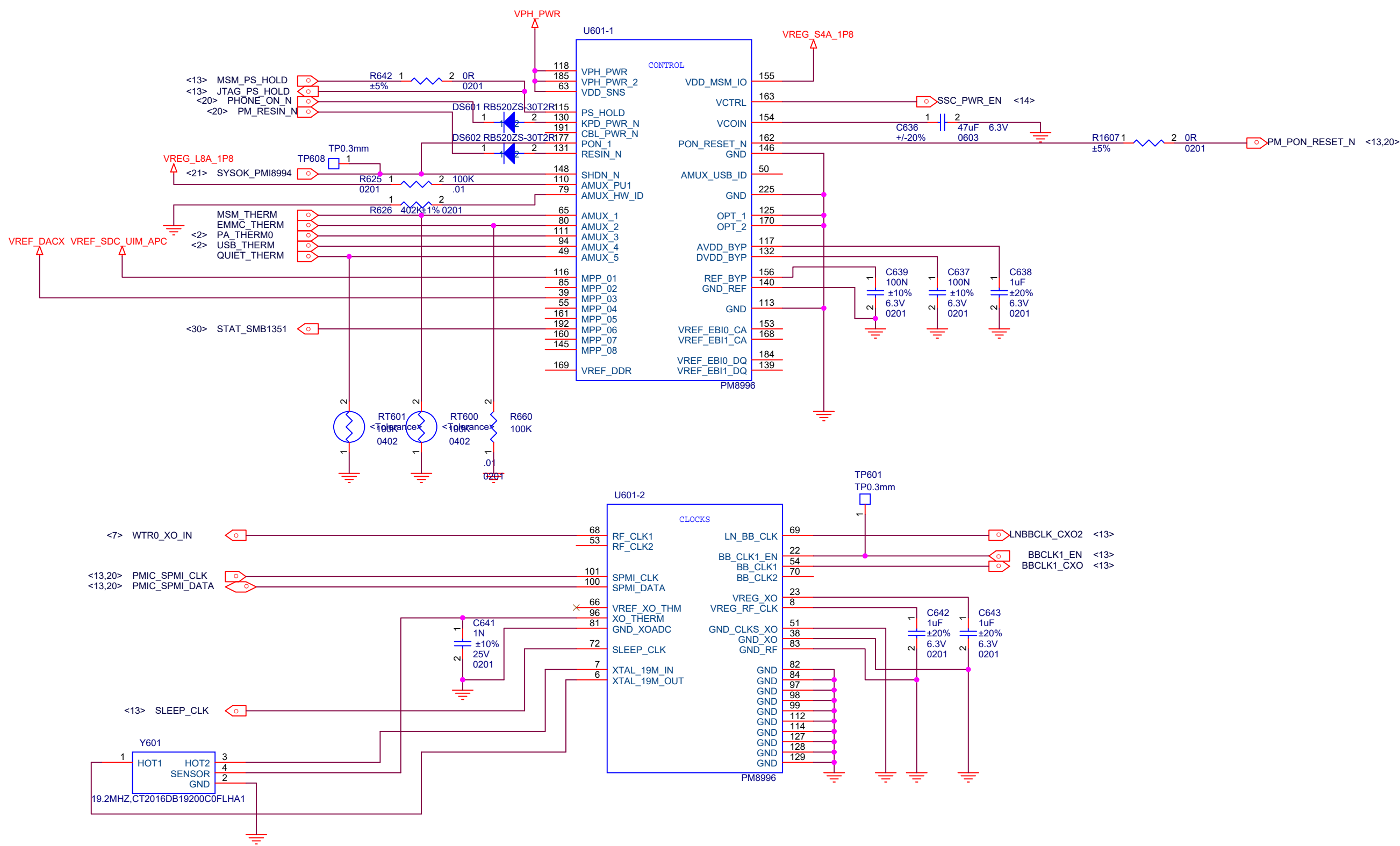

PM8996 CONTROL

Title		
B7		
Size	Document Number	Rev
A3	PM8996 CONTROL	P0
Date:	Wednesday, August 17, 2016	Sheet 24 of 35



D

C

B

A

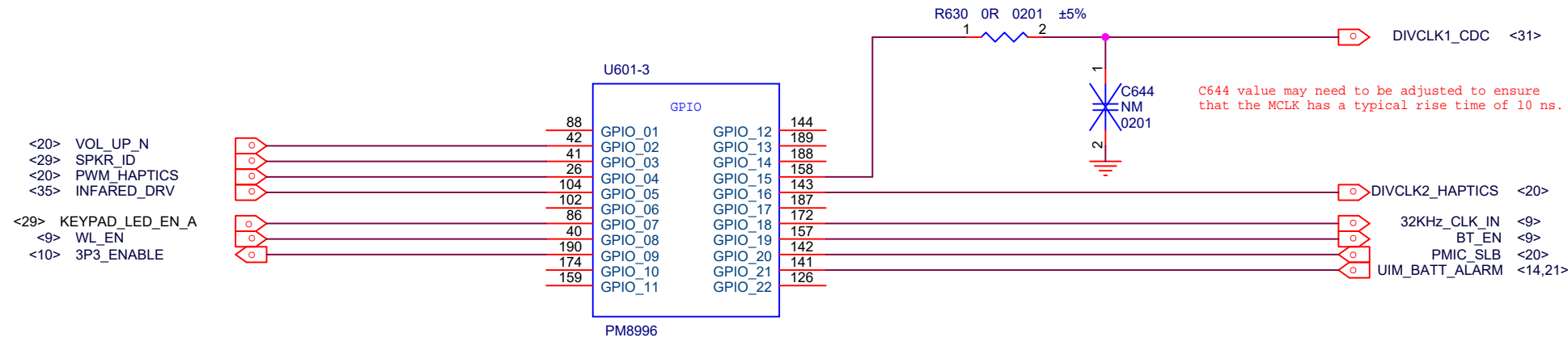

PM8996 GPIO

Title		
B7		
Size	Document Number	Rev
A3	PM8996 GPIO	P0
Date:	Wednesday, August 17, 2016	Sheet 25 of 35

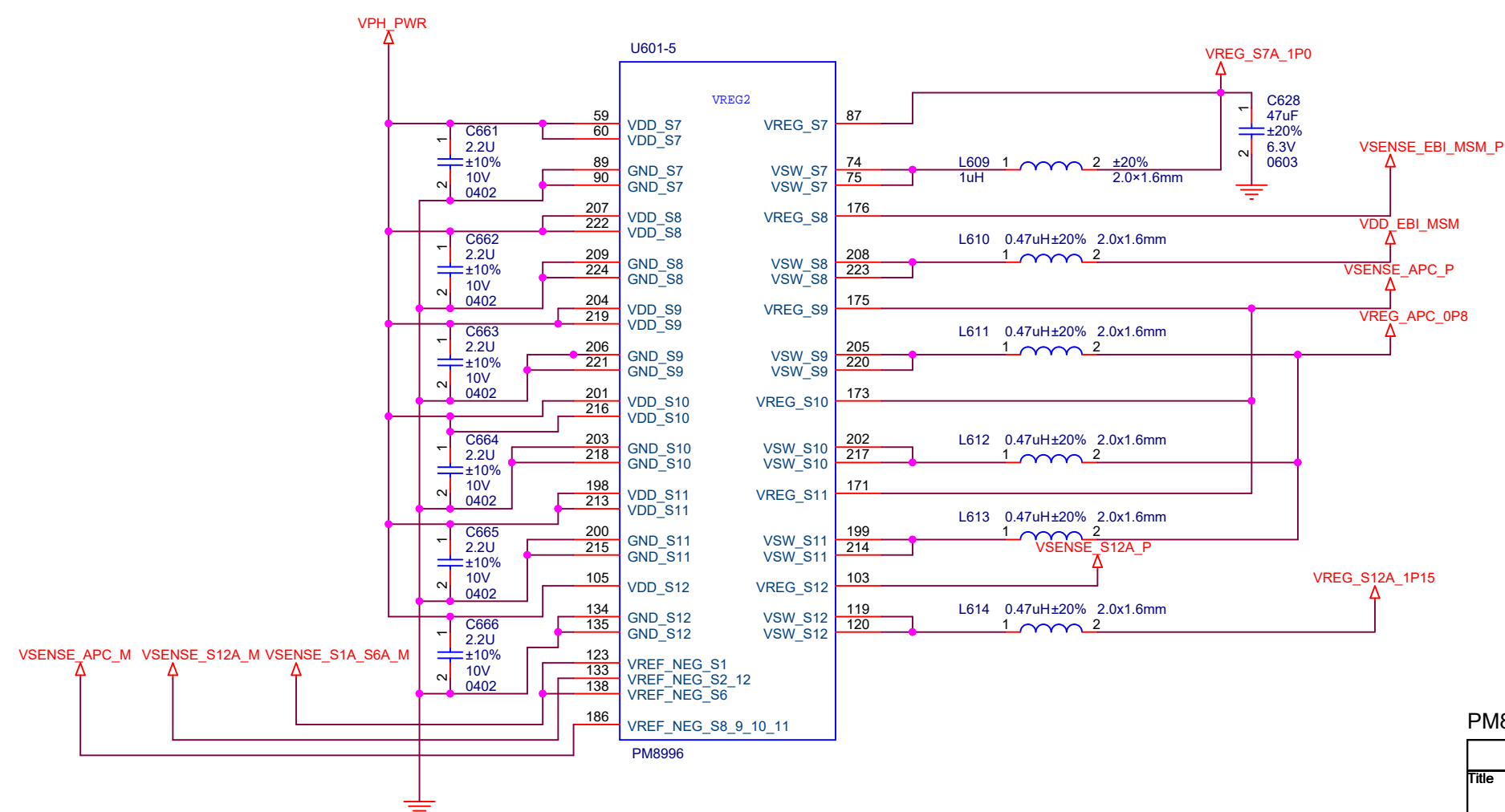
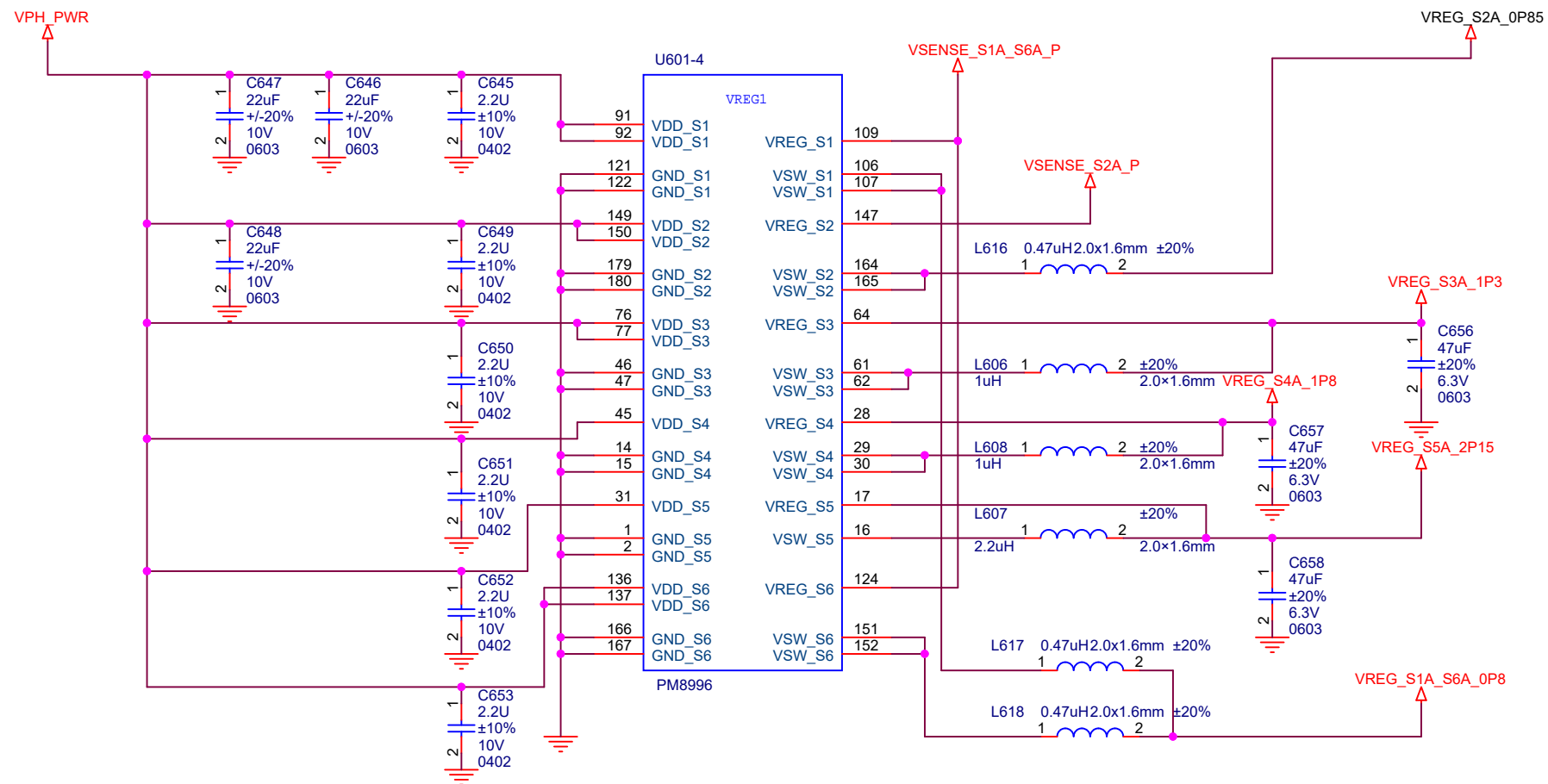

PM8996 VREG

Title		
B7		
Size	Document Number	Rev
A3	PM8996 VREG	P0
Date:	Wednesday, August 17, 2016	Sheet 26 of 35

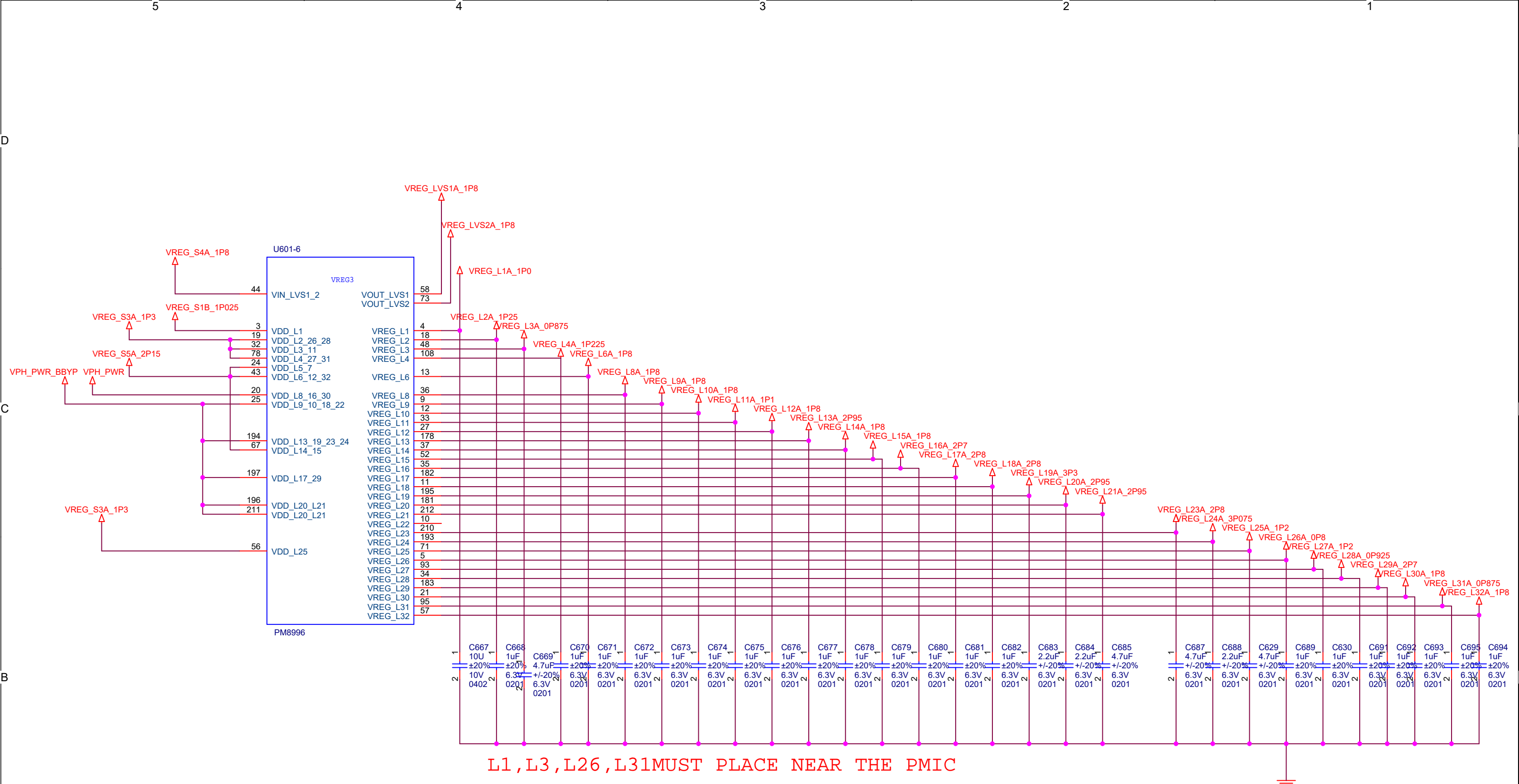

L1, L3, L26, L31 MUST PLACE NEAR THE PMIC

PM8996 LDO

Title		B7
Size	Document Number	Rev
A3	PM8996 LDO	P0
Date:	Wednesday, August 17, 2016	Sheet 27 of 35

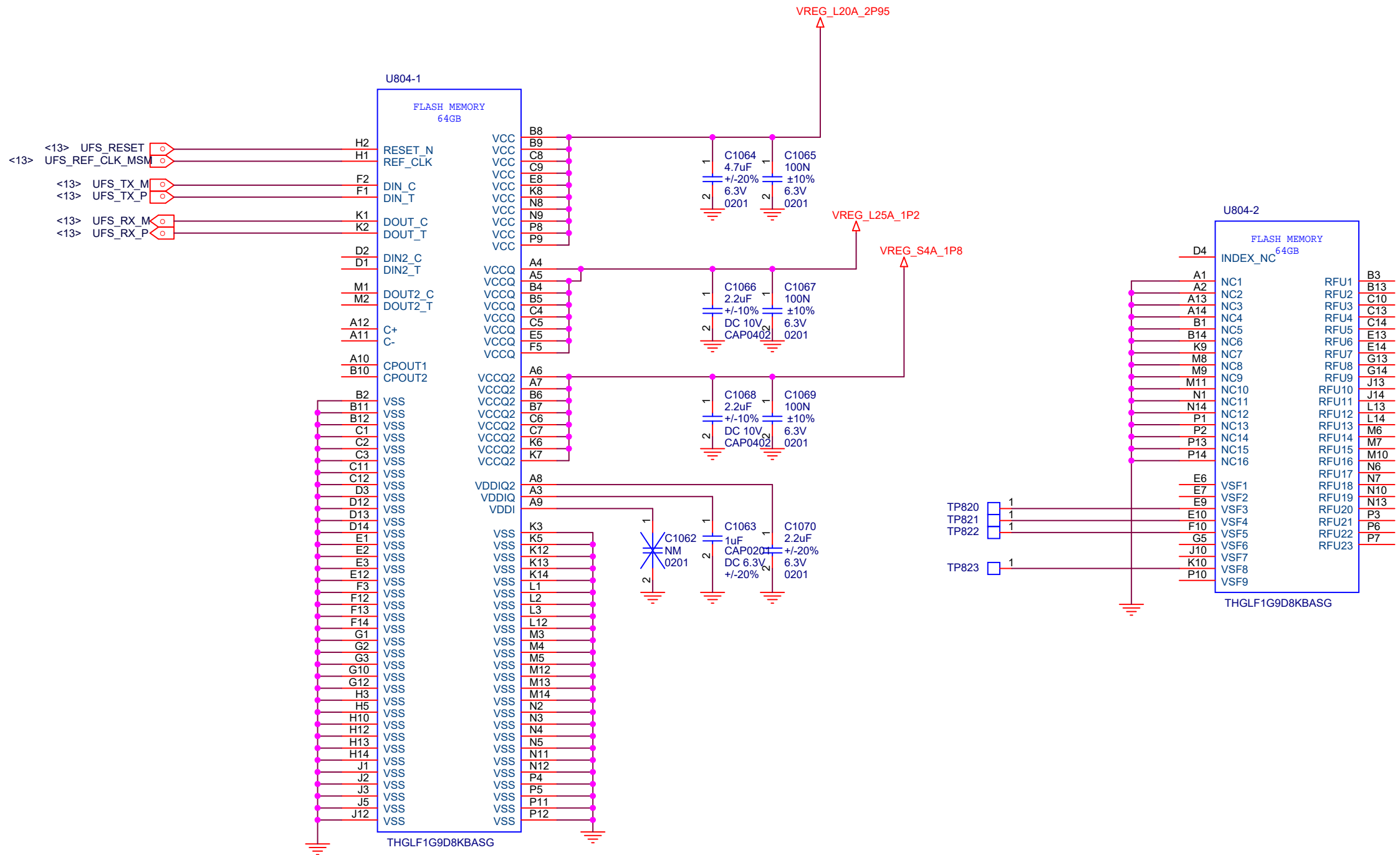

MEMORY UFS

Title			B7
Size	Document Number	Rev	
A3	MEMORY UFS	P0	
Date:	Wednesday, August 17, 2016	Sheet	28 of 35

# HANDSET

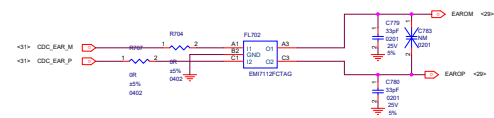

# AUX Mic2

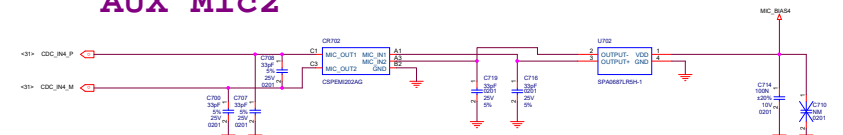

# AUX Mic1

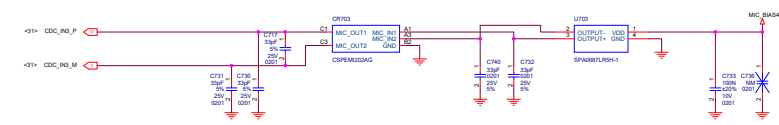

# HEADSET

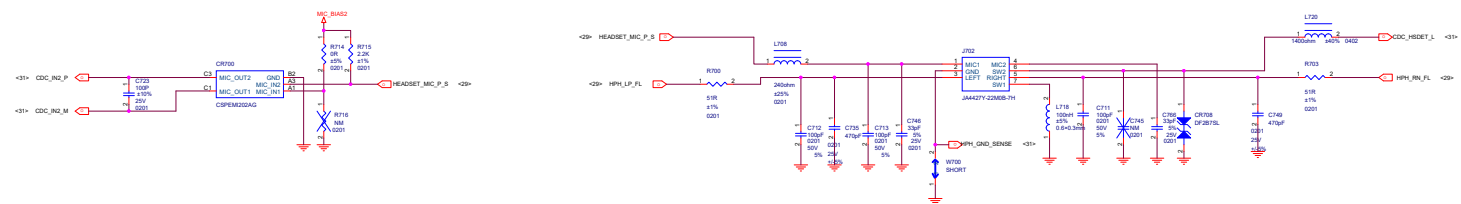
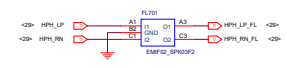
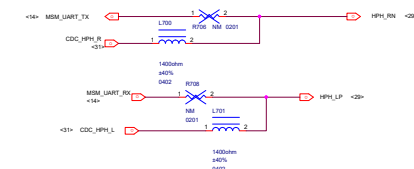

# Speaker PA

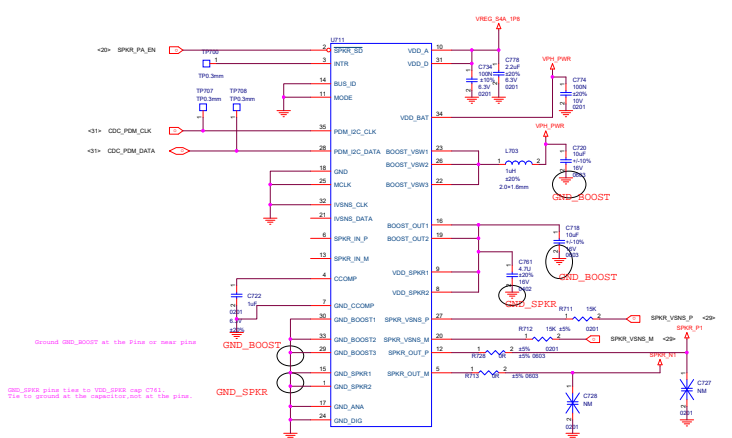

Ground GND\_BOOST at the pin or near pin  
 VDD\_BOOST pin line to VDD\_BOOST and CT10 tie to ground at the capacitor end at the pin.

# KEYPAD LED DRIVER

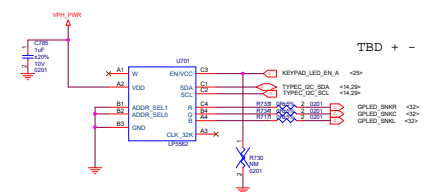

TBD + -

# Bottom fpc Connector

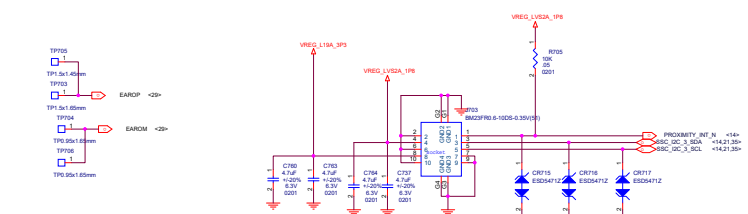
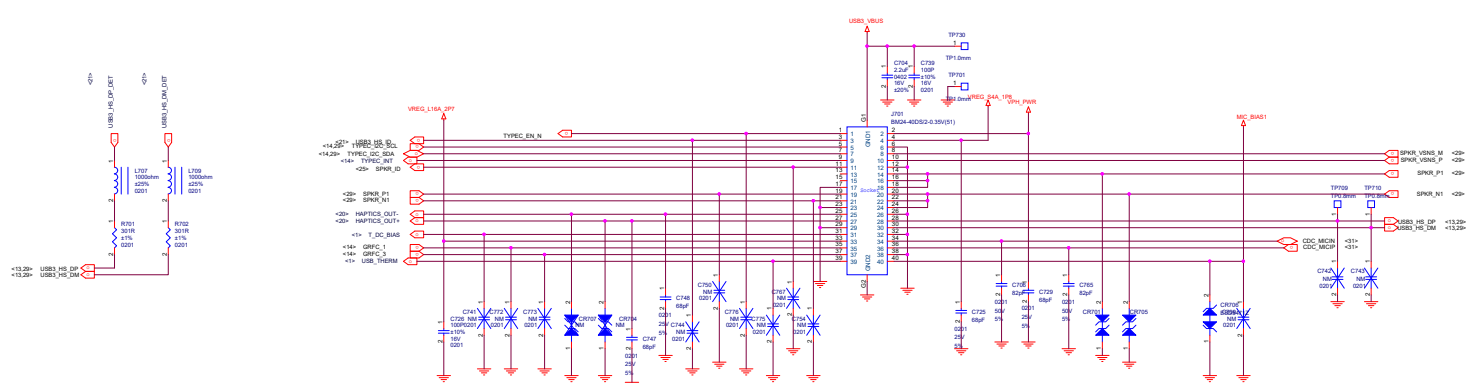

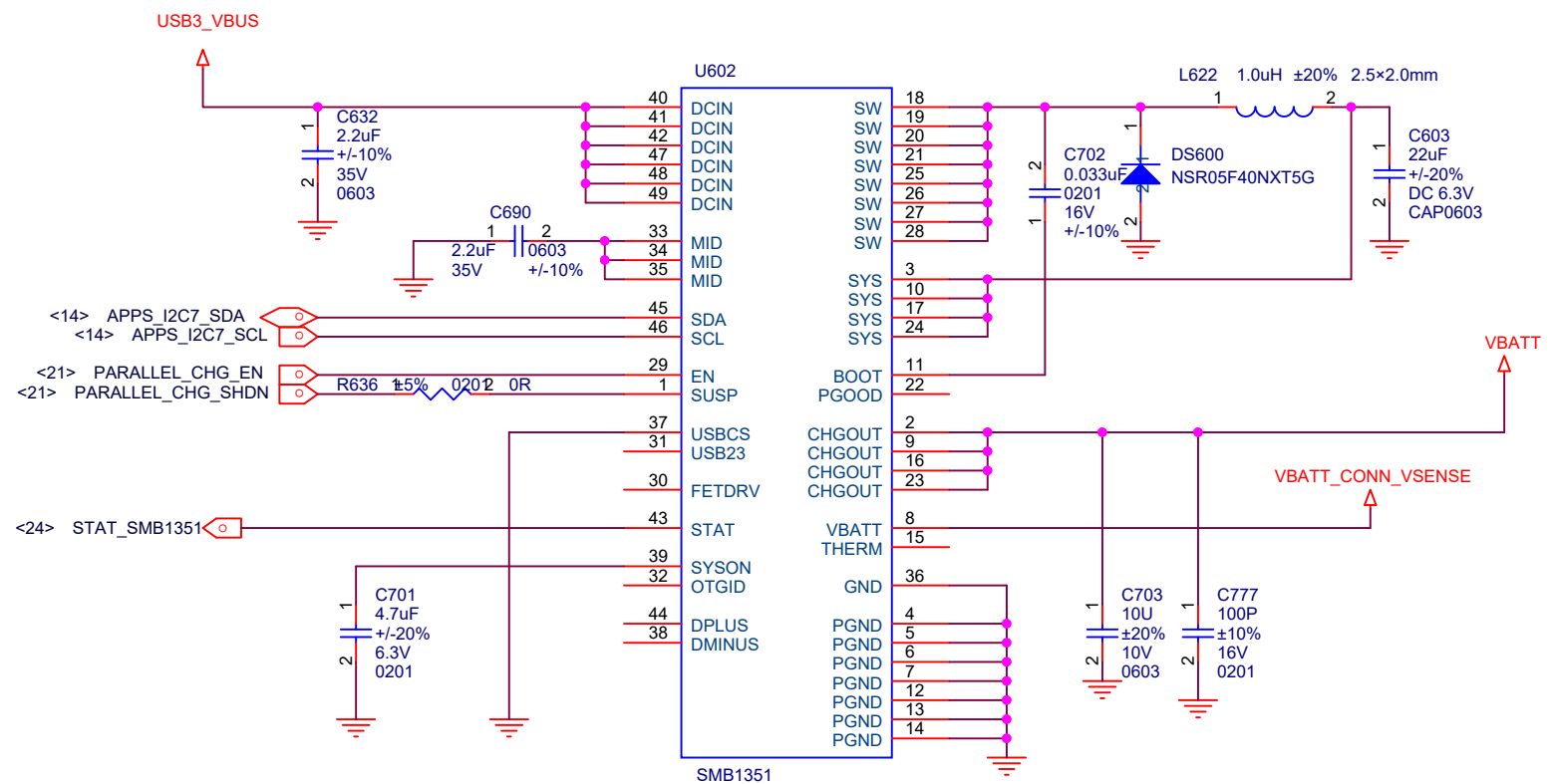

SMB1357 CHARGER

Title		
B7		
Size	Document Number	Rev
A3	SMB1351 CHARGER	P0
Date:	Wednesday, August 17, 2016	Sheet 30 of 35

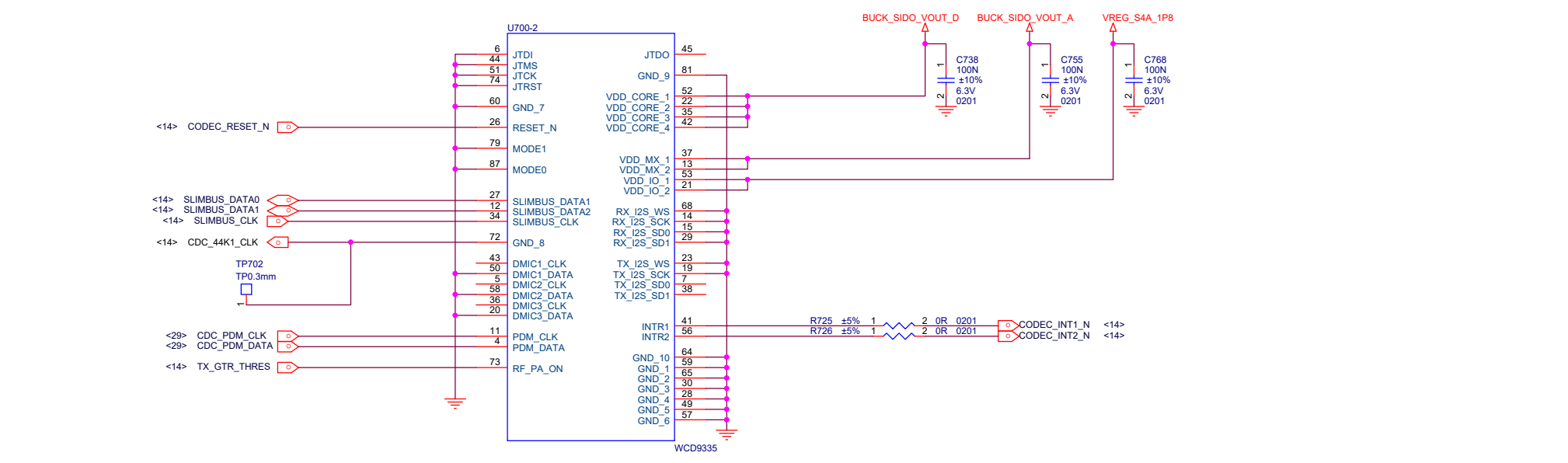
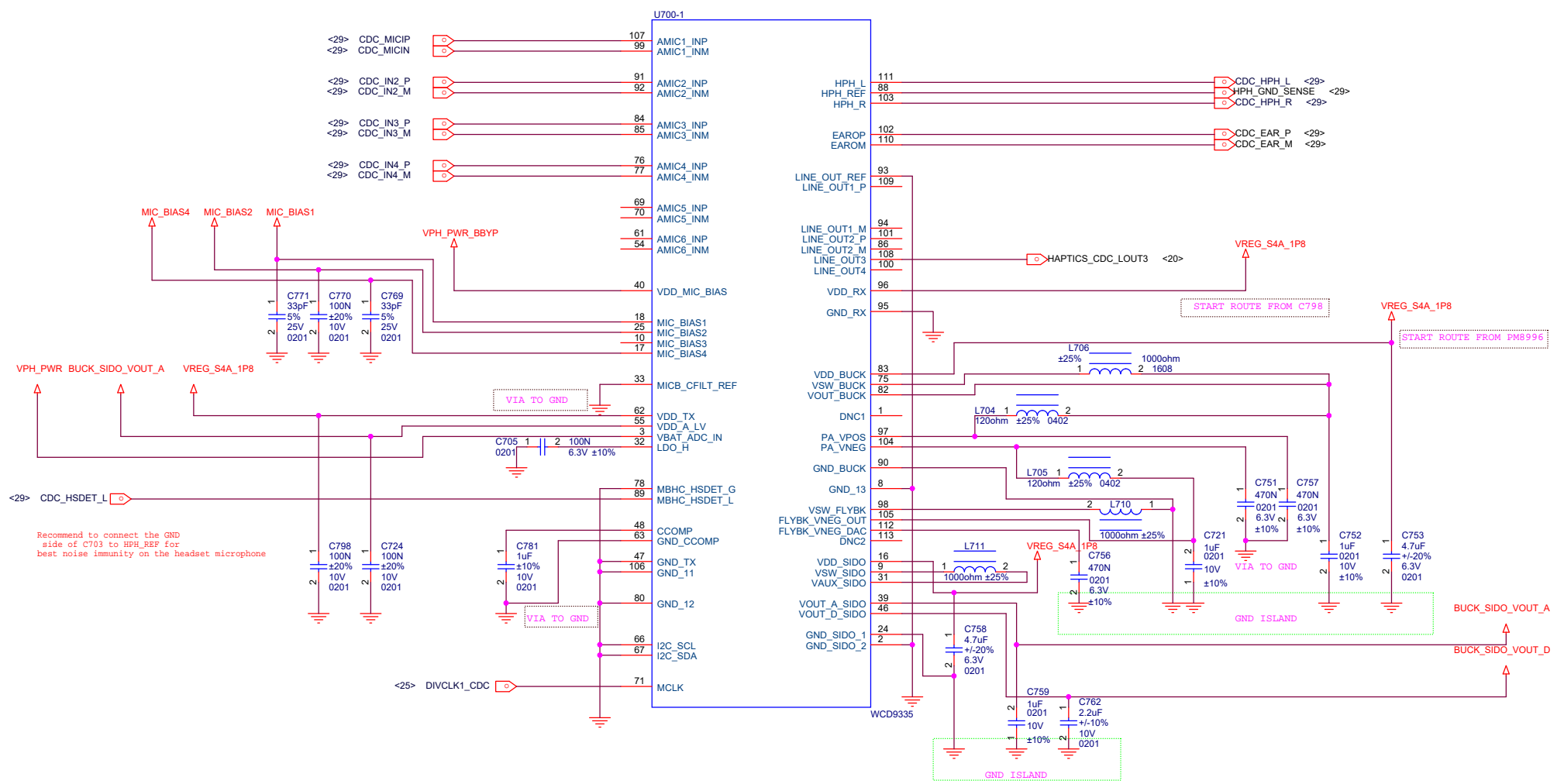

Recommend to connect the GND side of C703 to HPH\_REF for best noise immunity on the headset microphone

WCD9335			
Title			
B7			
Size	Document Number	Rev	
A2	WCD9335	P0	
Date:	Wednesday, August 17, 2016	Sheet	31 of 35

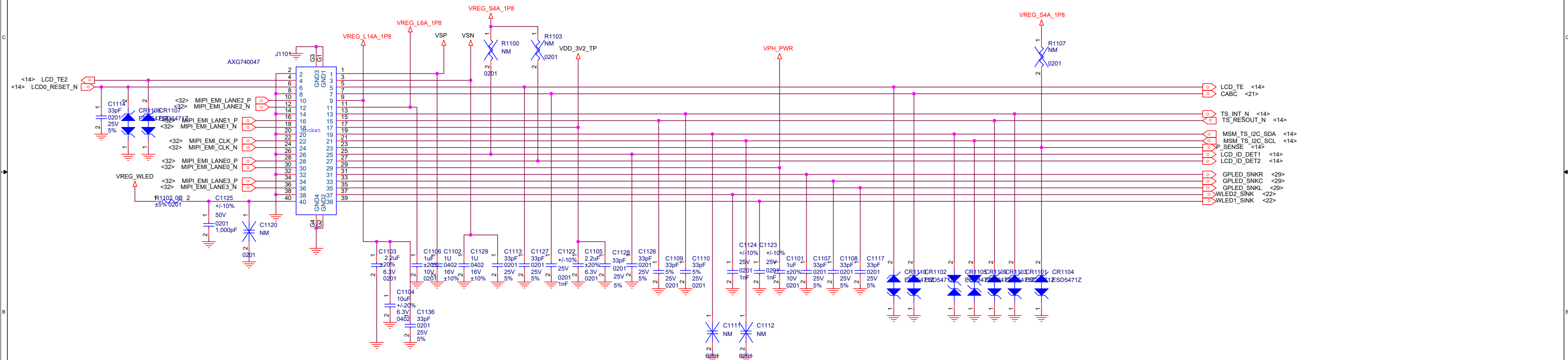
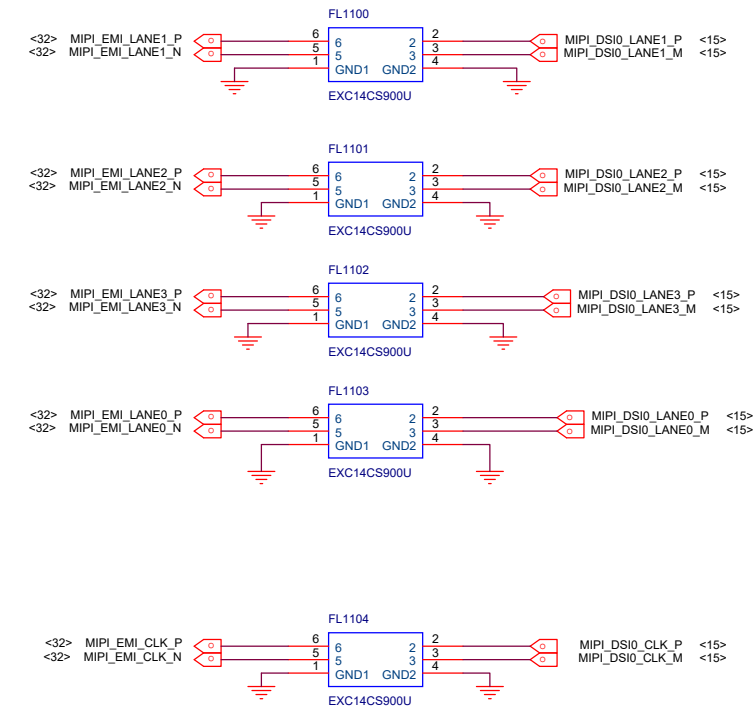
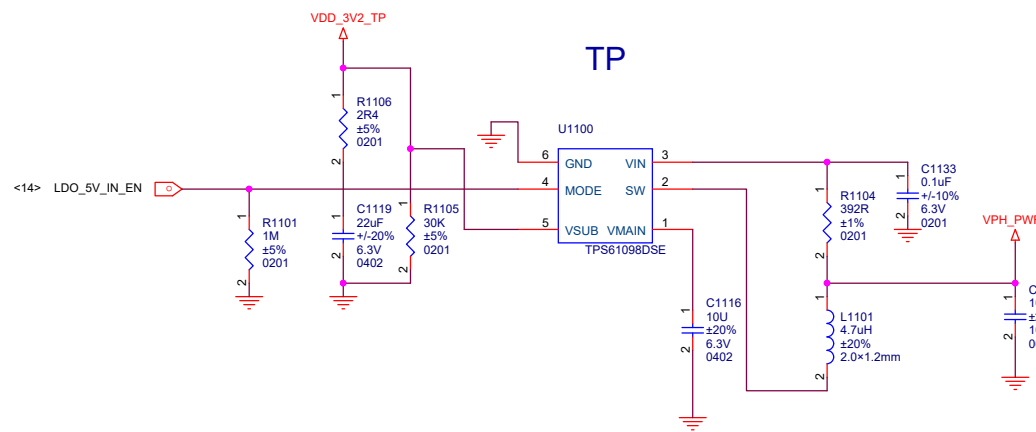

LCD		
<b>XIAO MI</b>		
Title	B7	
Size	Document Number	Rev
A2	LCD	P0
Date:	Wednesday, August 17, 2016	Sheet 32 of 35



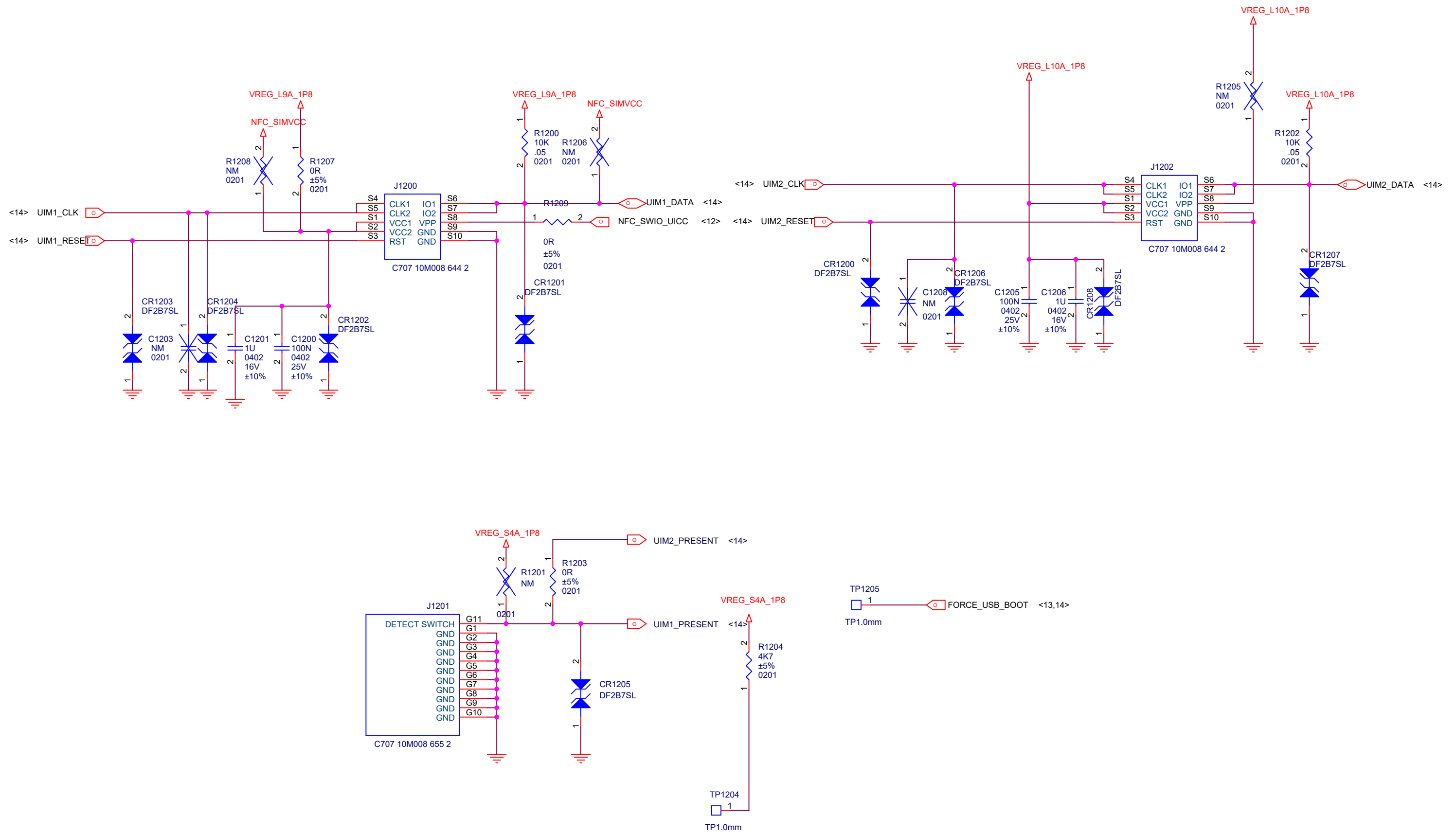

SIM CONNECTOR		
XIAO MI		
Title B7		
Size A3	Document Number	Rev P0
Date:	Sheet 33 of 35	

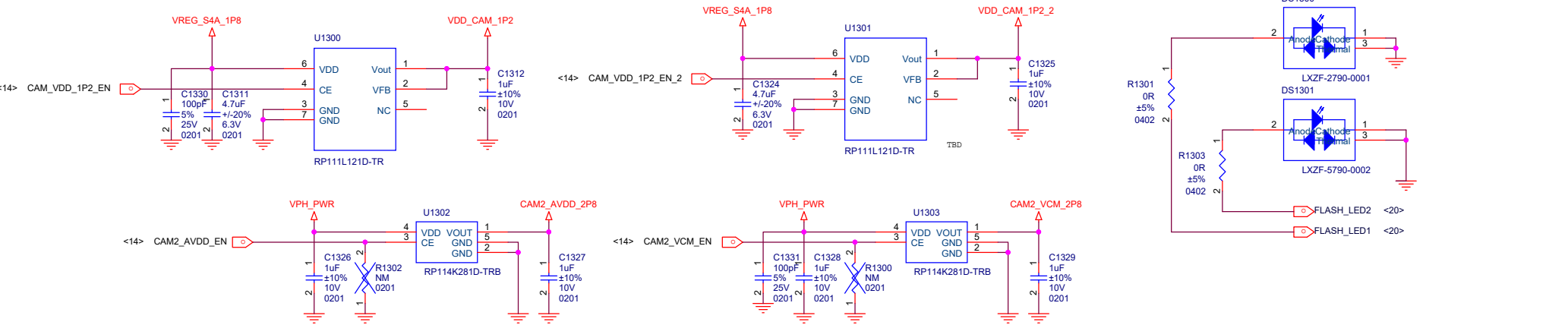

# Rear Cam

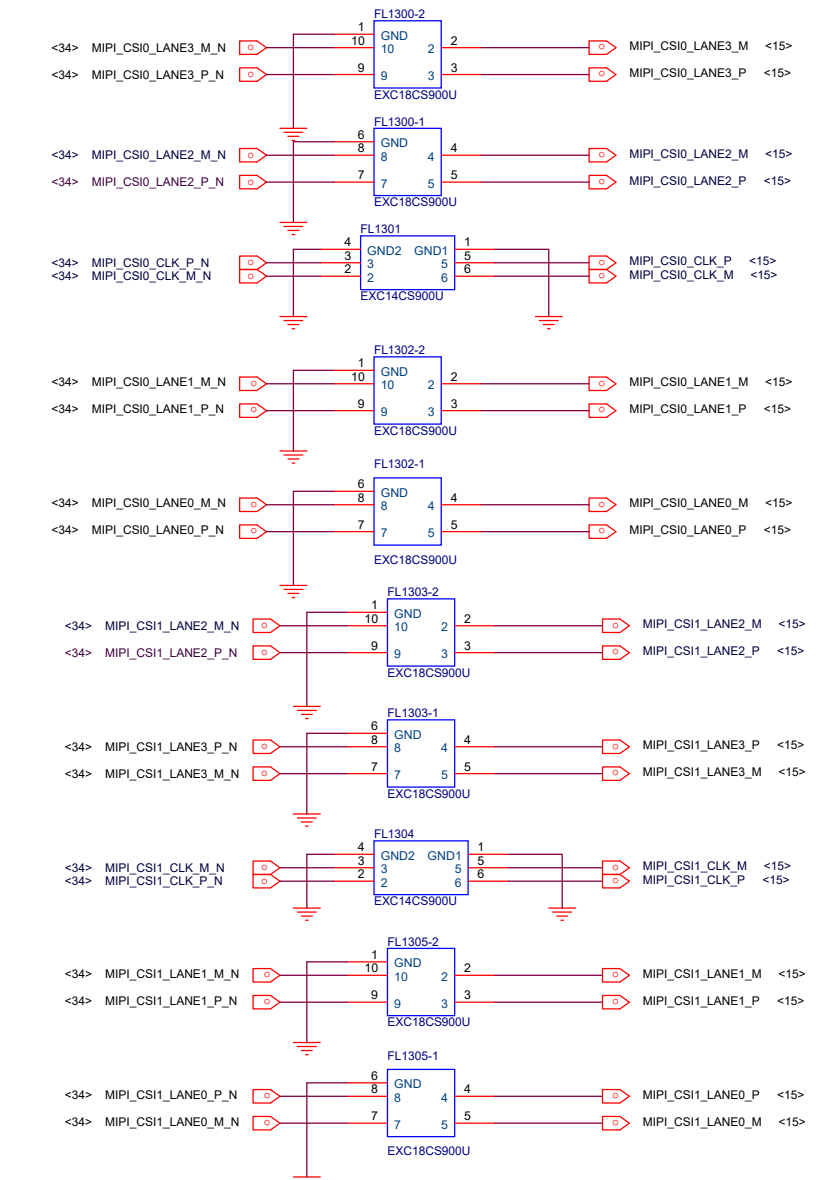
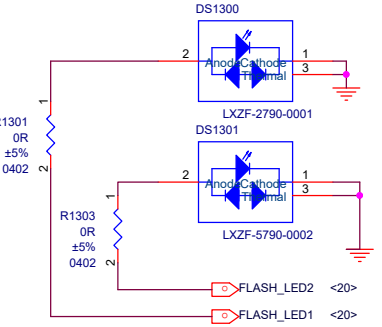
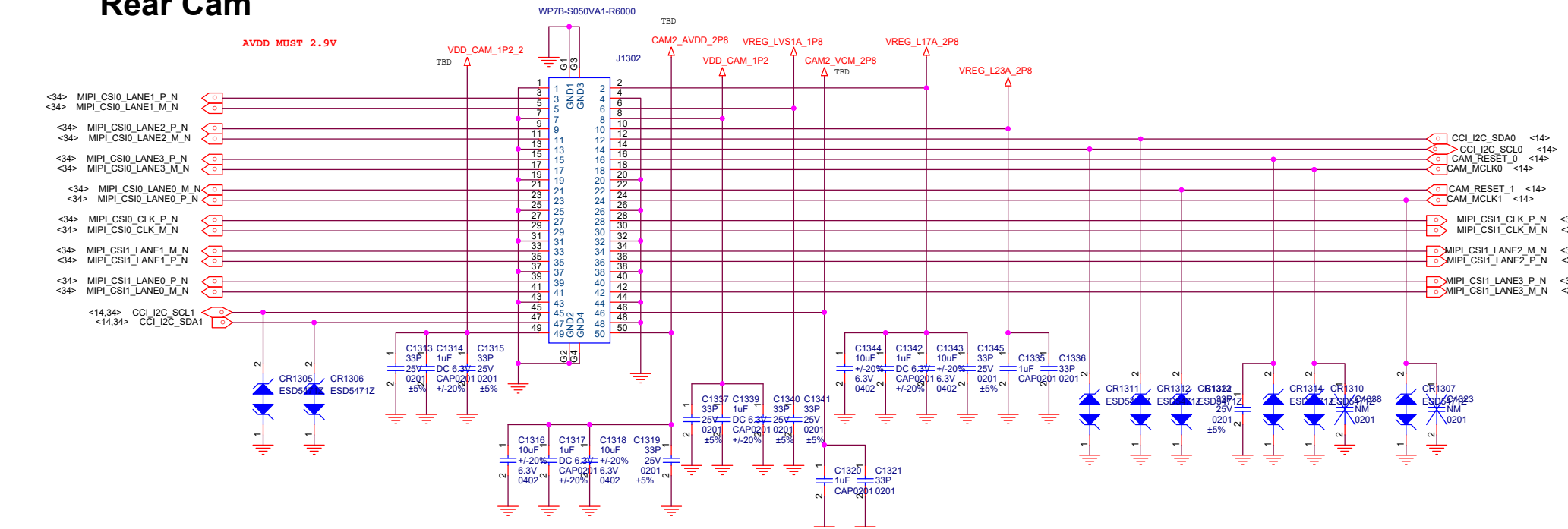

# FRONT CAMERA

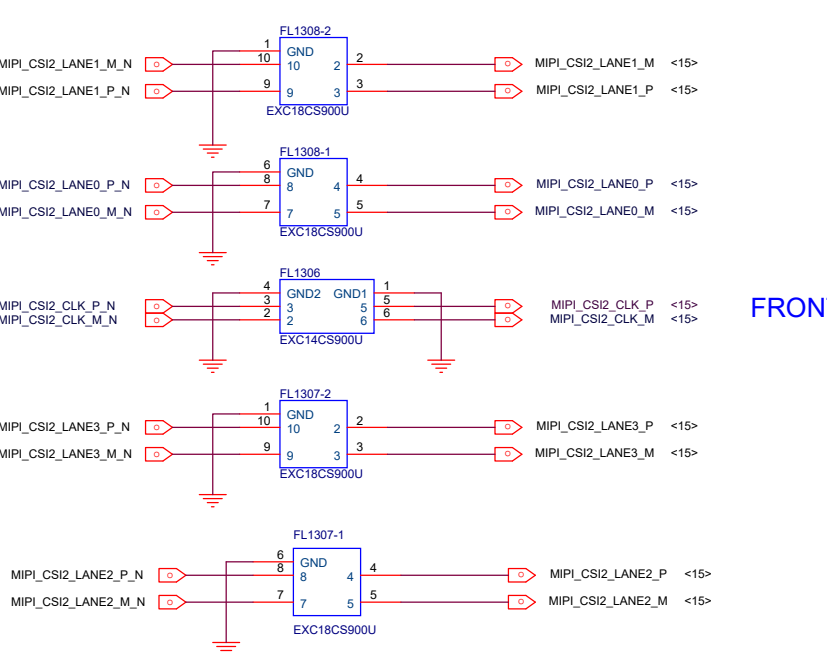

CAMERA		
XIAO MI		
Title	B7	
Size	Document Number	Rev P0
Date:	Sheet 34 of 35	

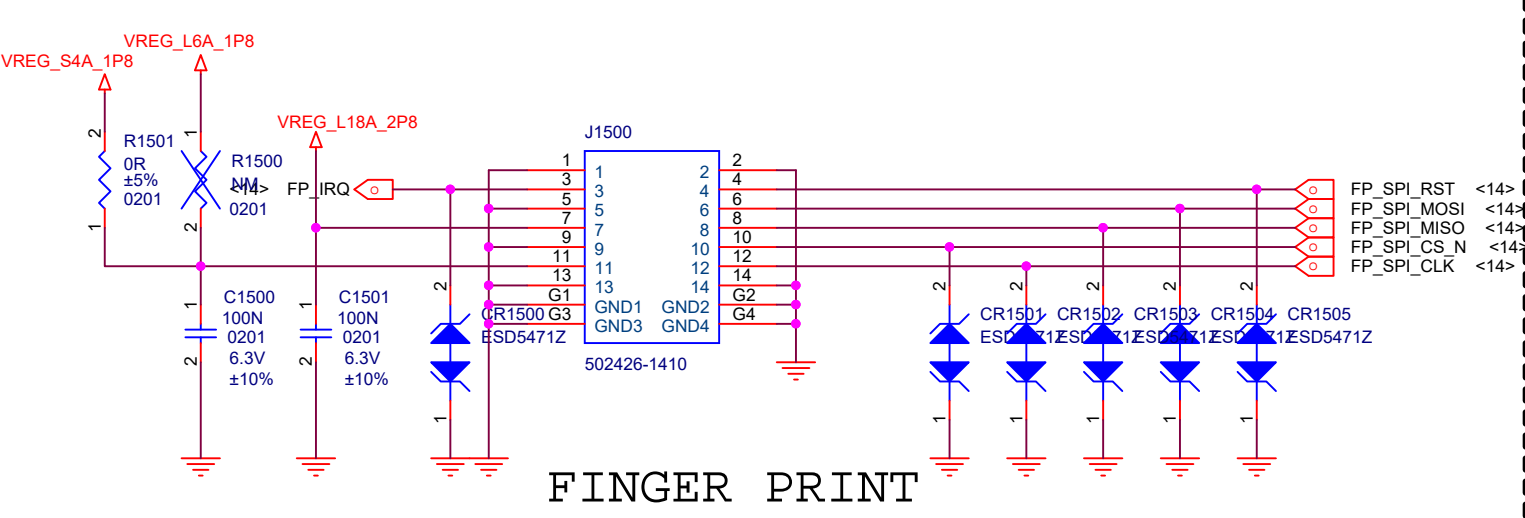

FINGER PRINT

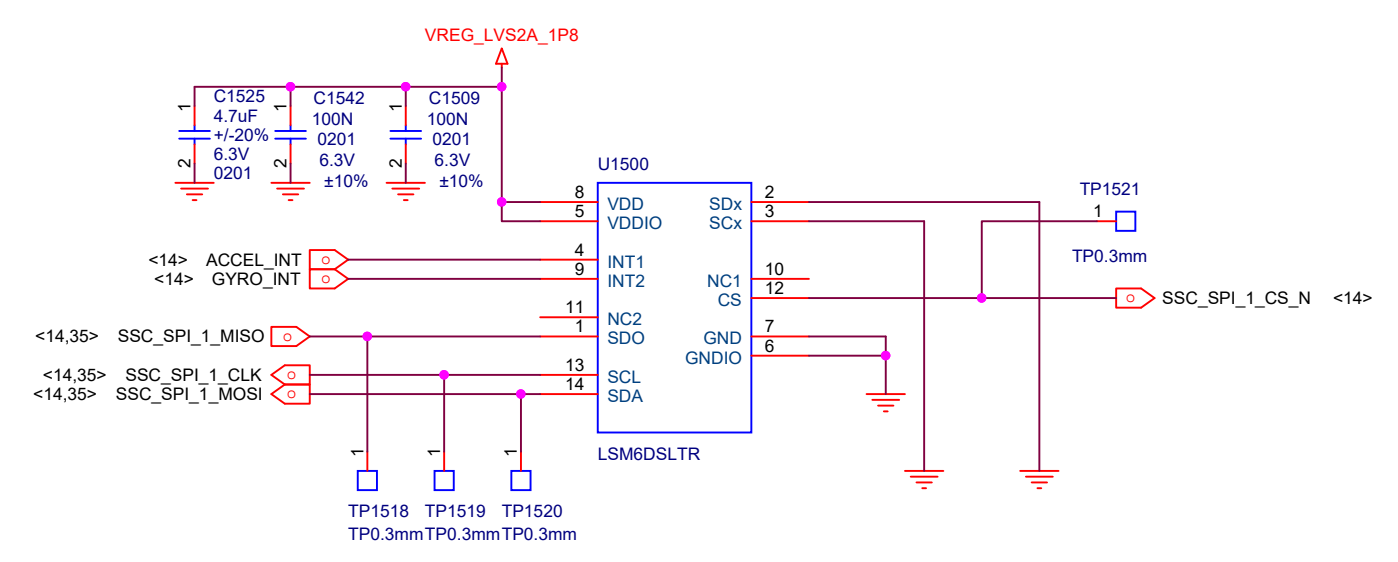

G+G

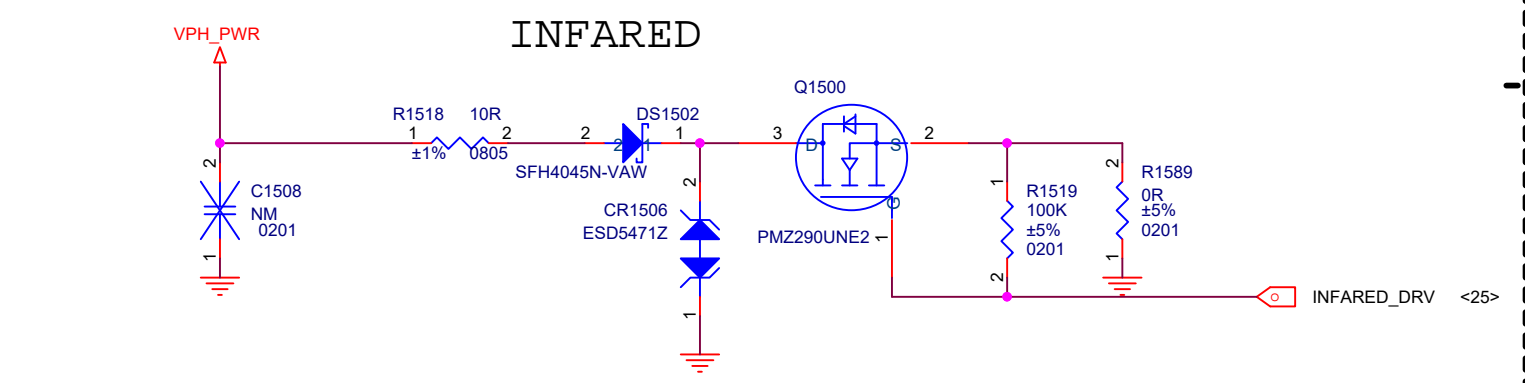

INFARED

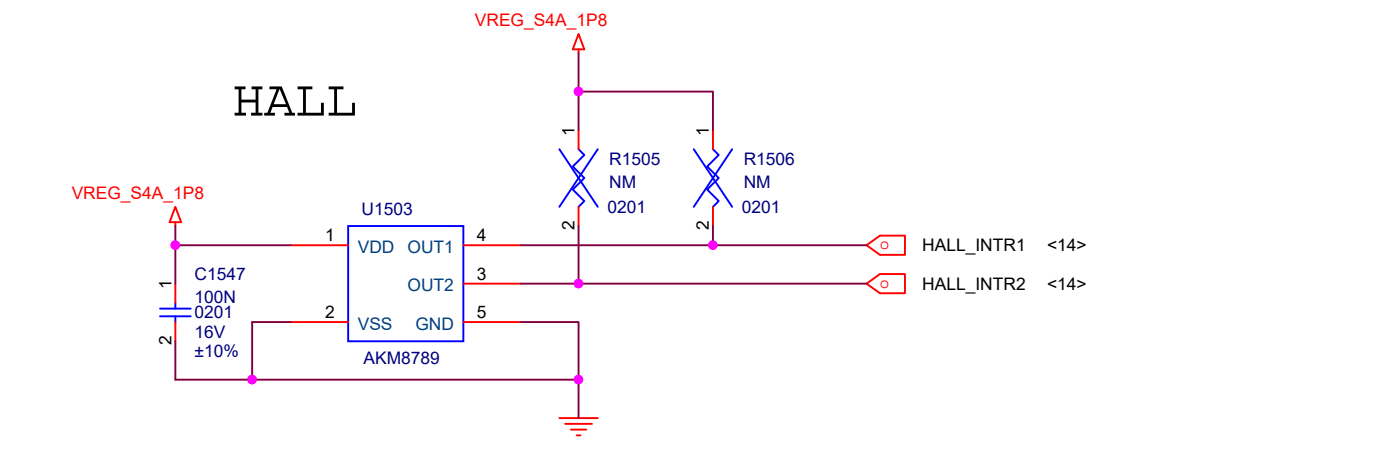

HALL

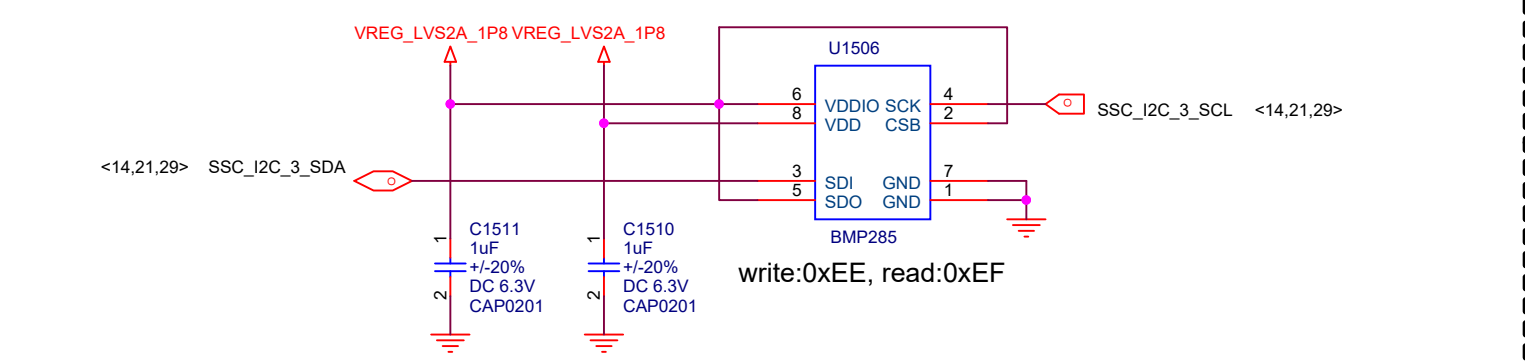

PRESSURE

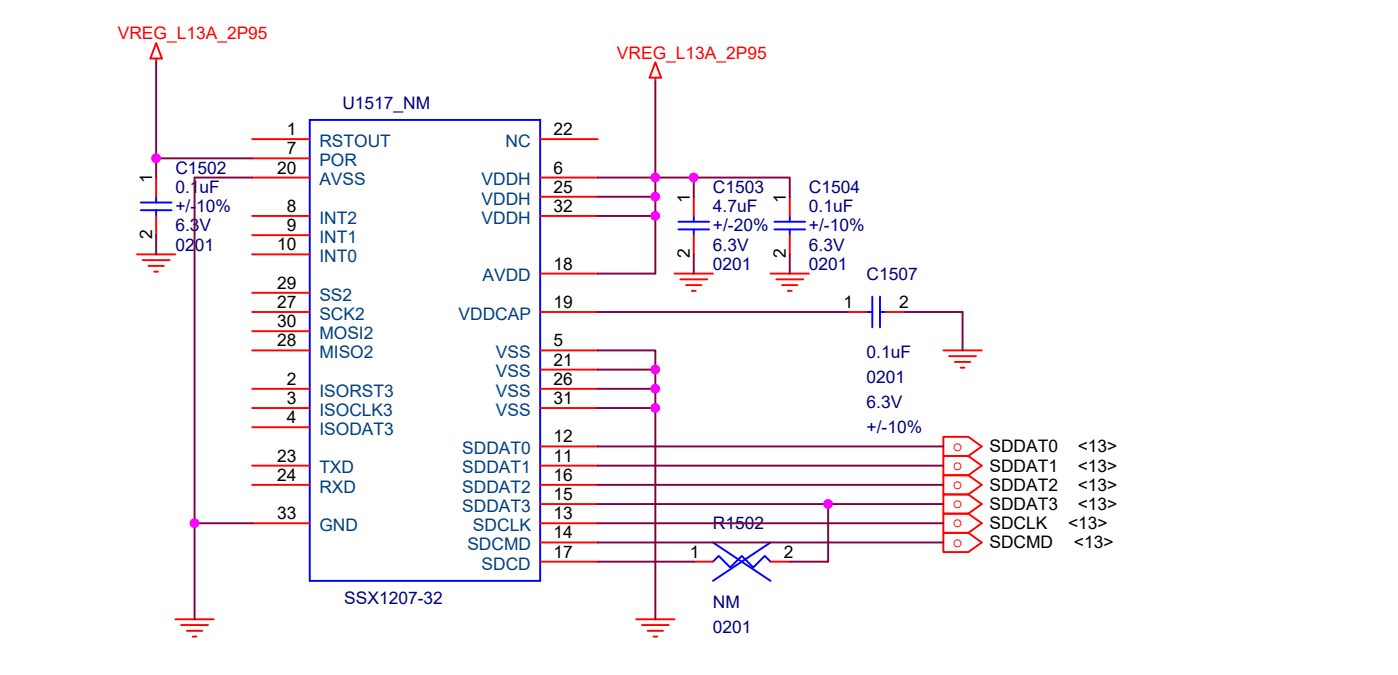

PRESSURE

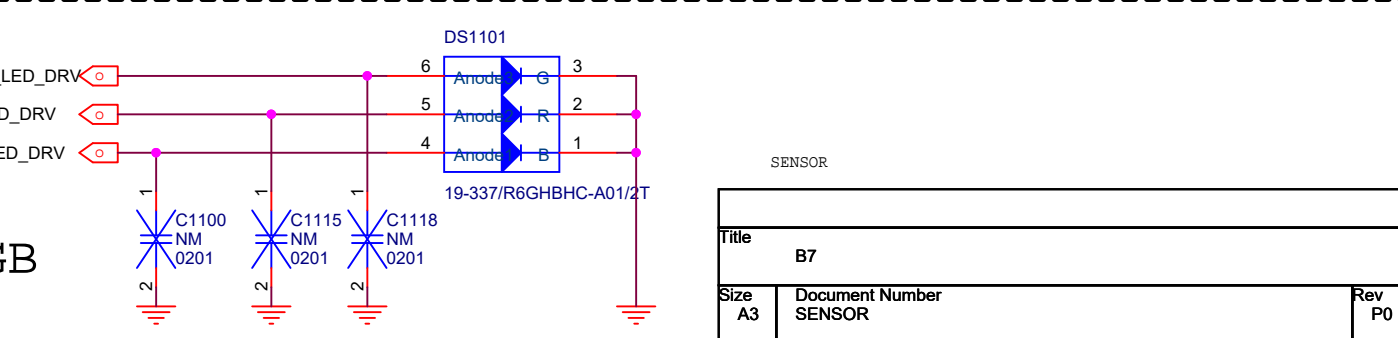

RGB

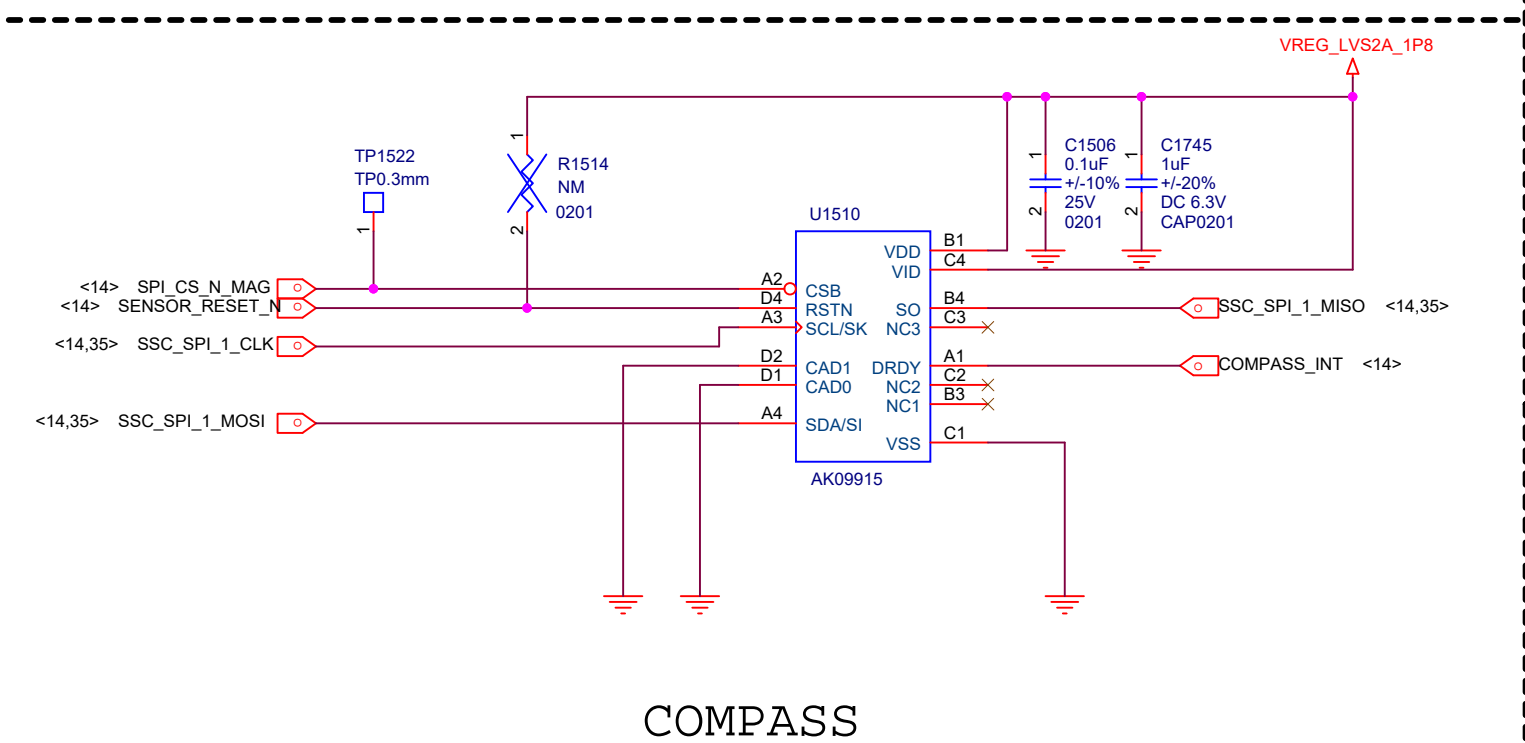

COMPASS

Title		B7
Size	Document Number	Rev
A3	SENSOR	P0
Date:	Sheet	35 of 35