

DRX_ANT

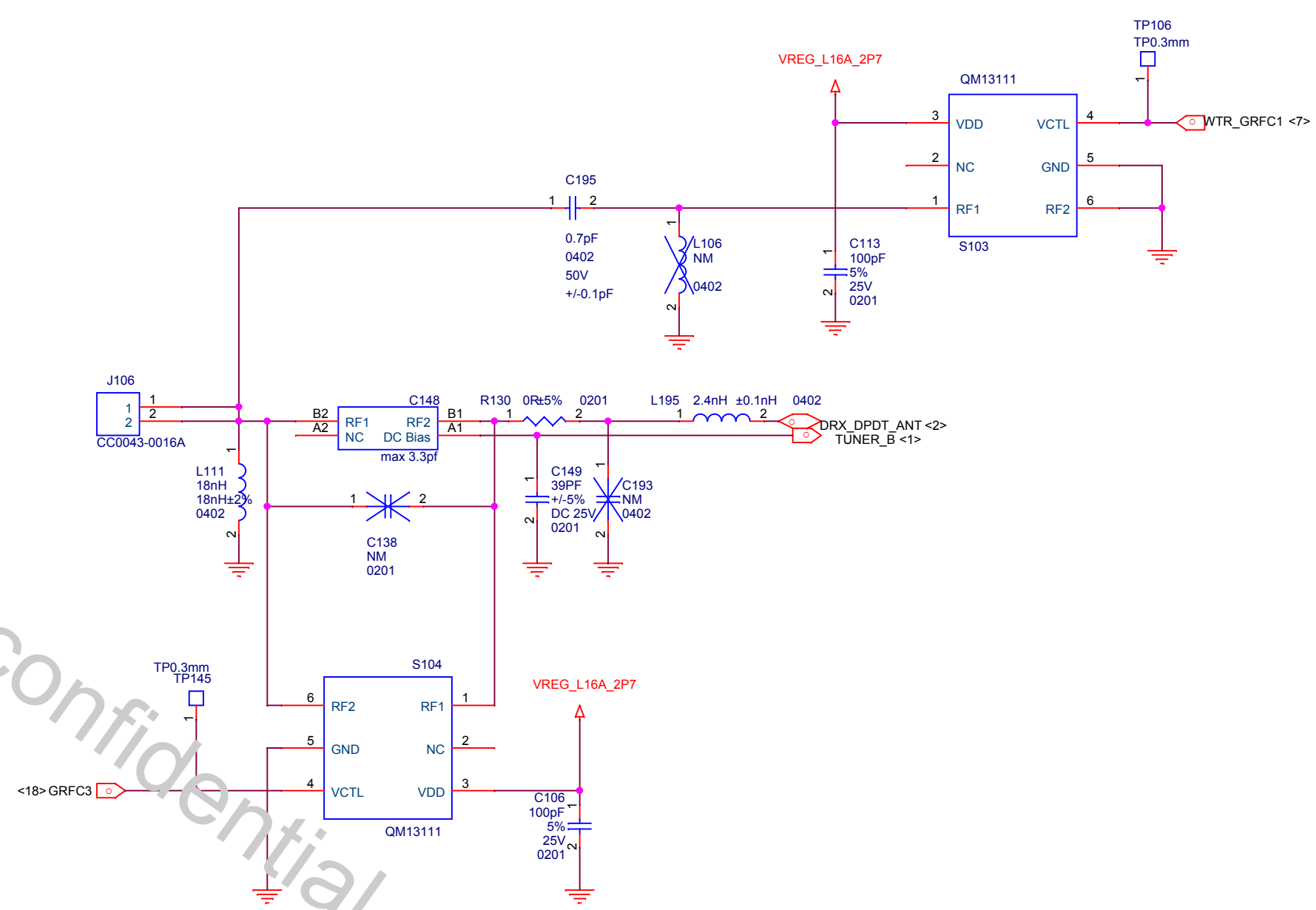

TUNER_CTR

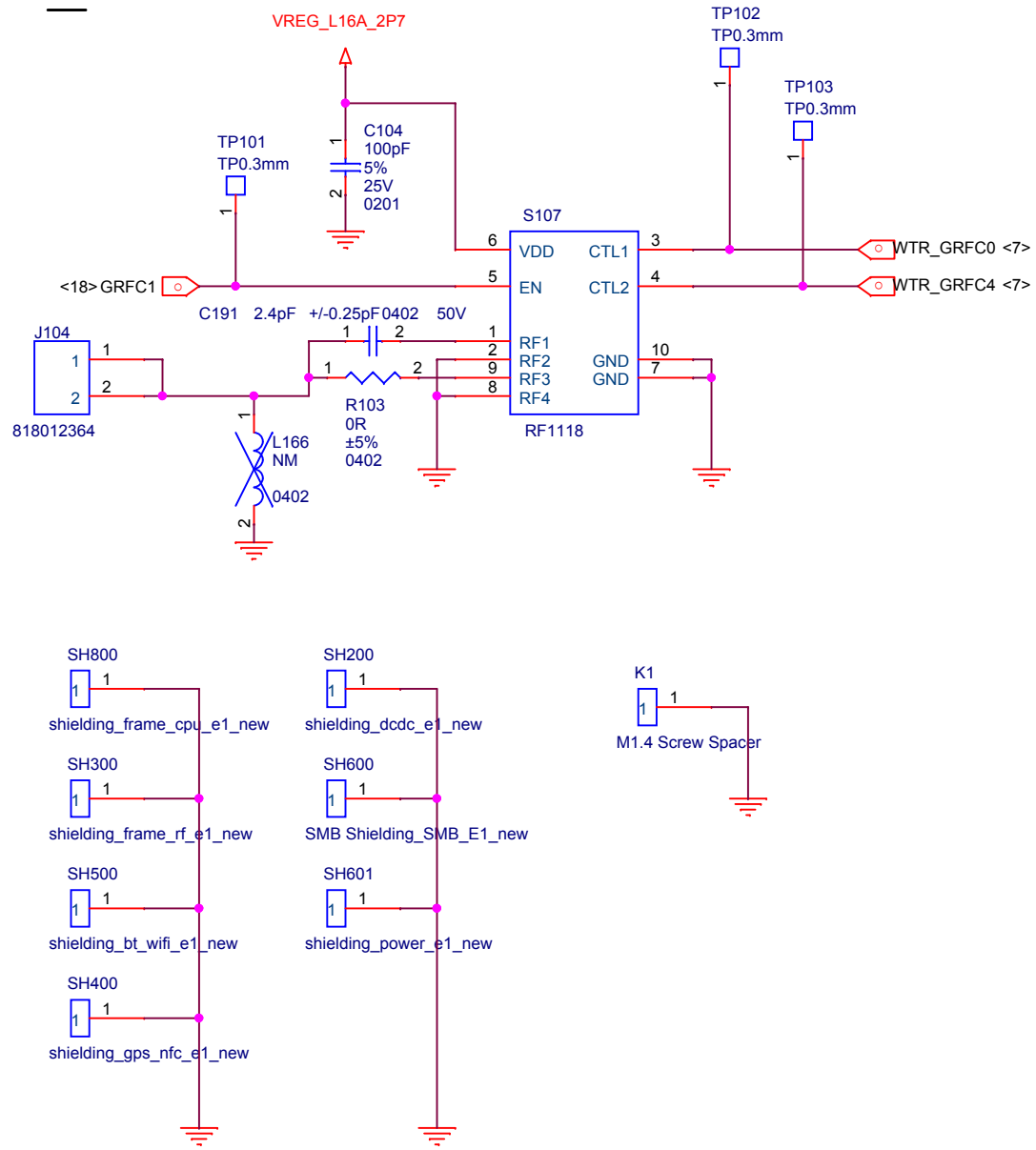
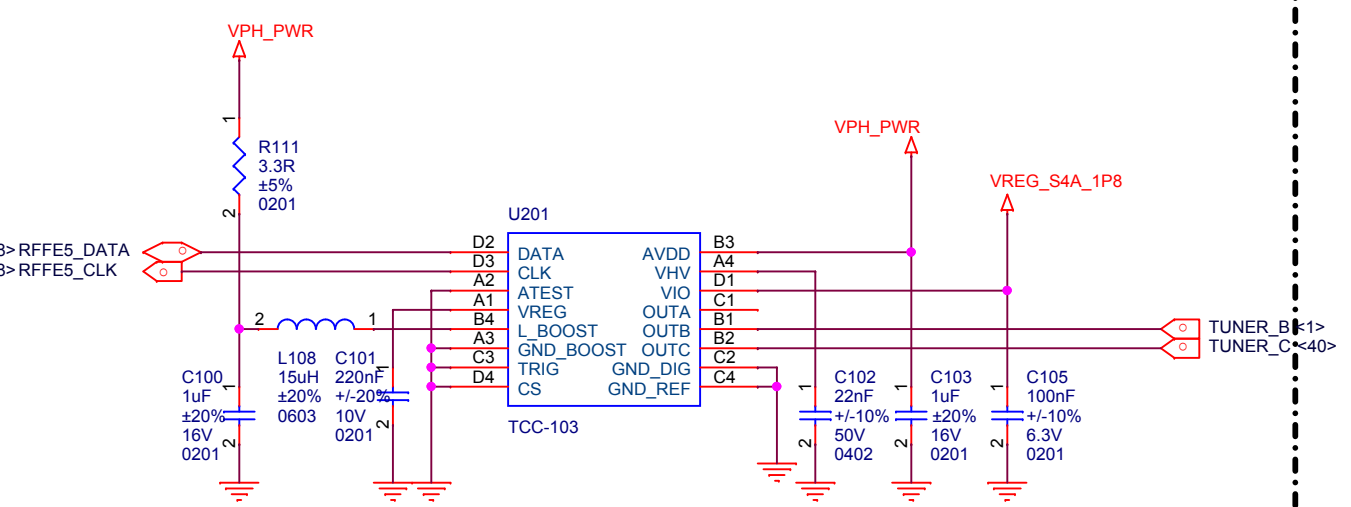

4X4_MIMO_ANT3

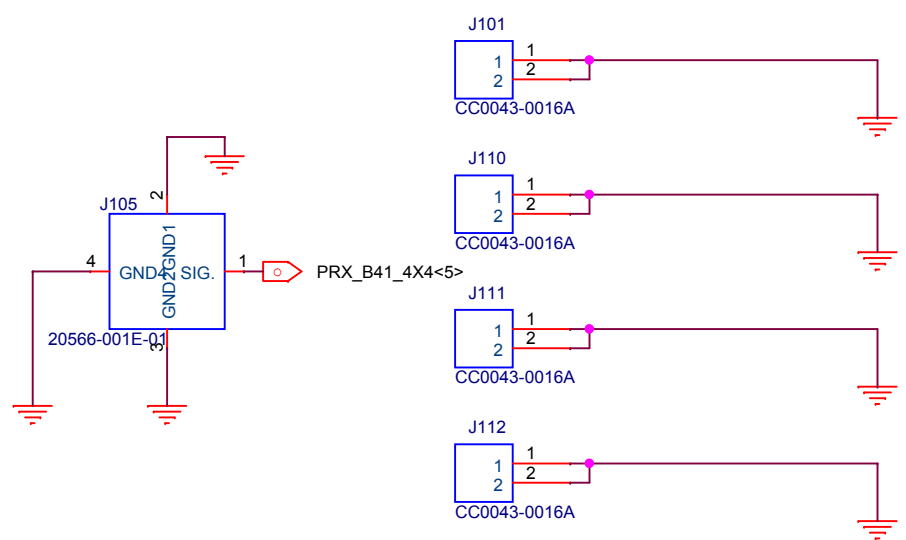

4X4_MIMO_ANT4

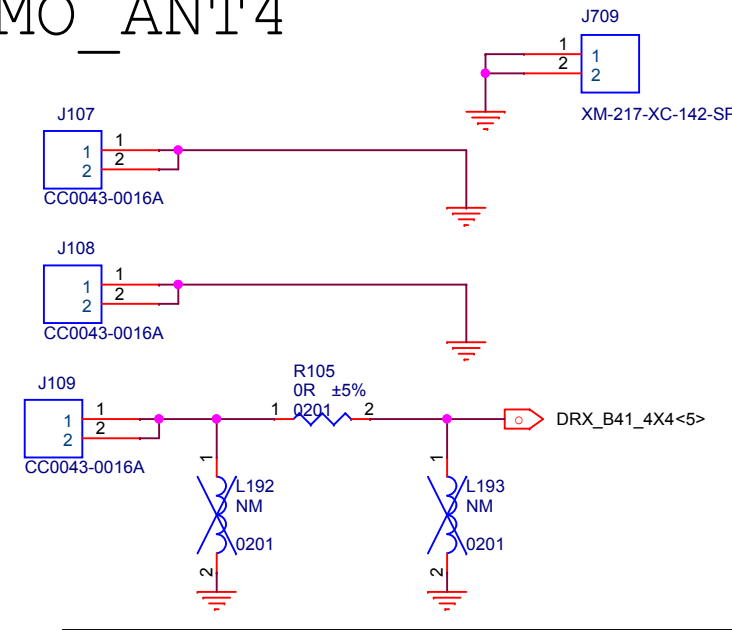

Title		E8	
Size	Document Number	ANT	
Date:	Monday, April 02, 2018	Sheet	1 of 44

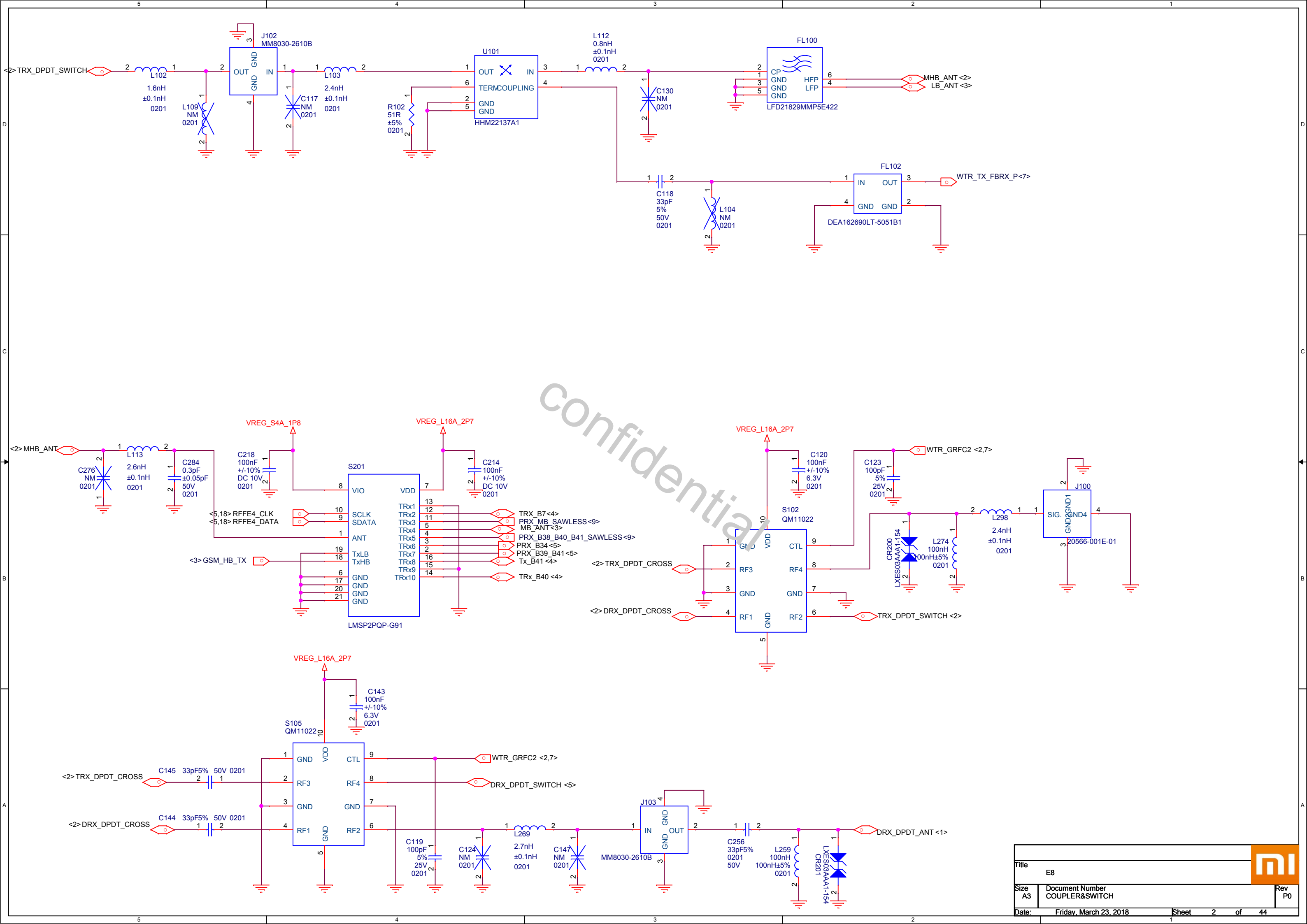

Confidential

Title		E8	
Size	Document Number	COUPLER&SWITCH	
A3			P0
Date:	Friday, March 23, 2018	Sheet	2 of 44

2GPA

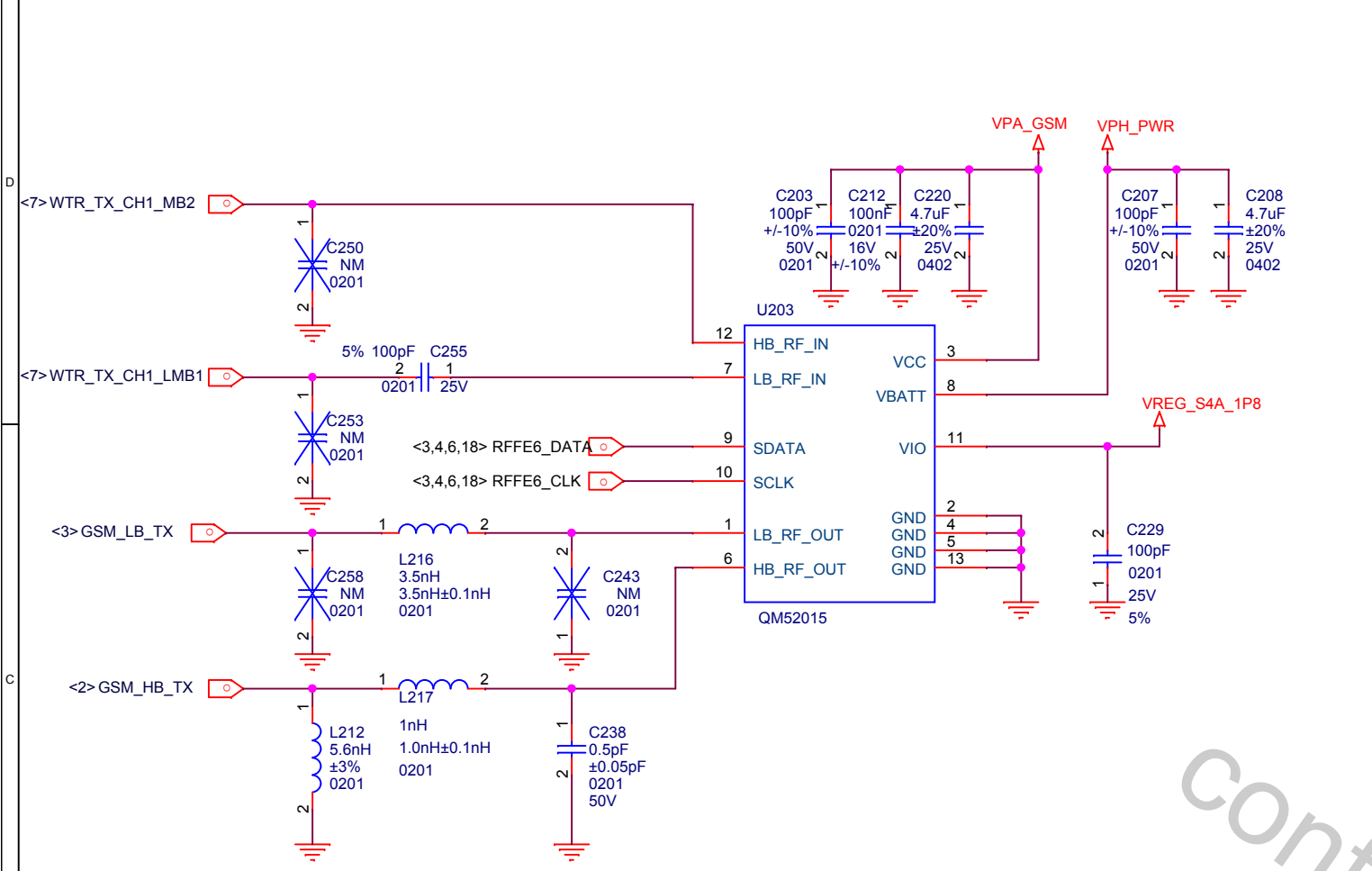

LBPA

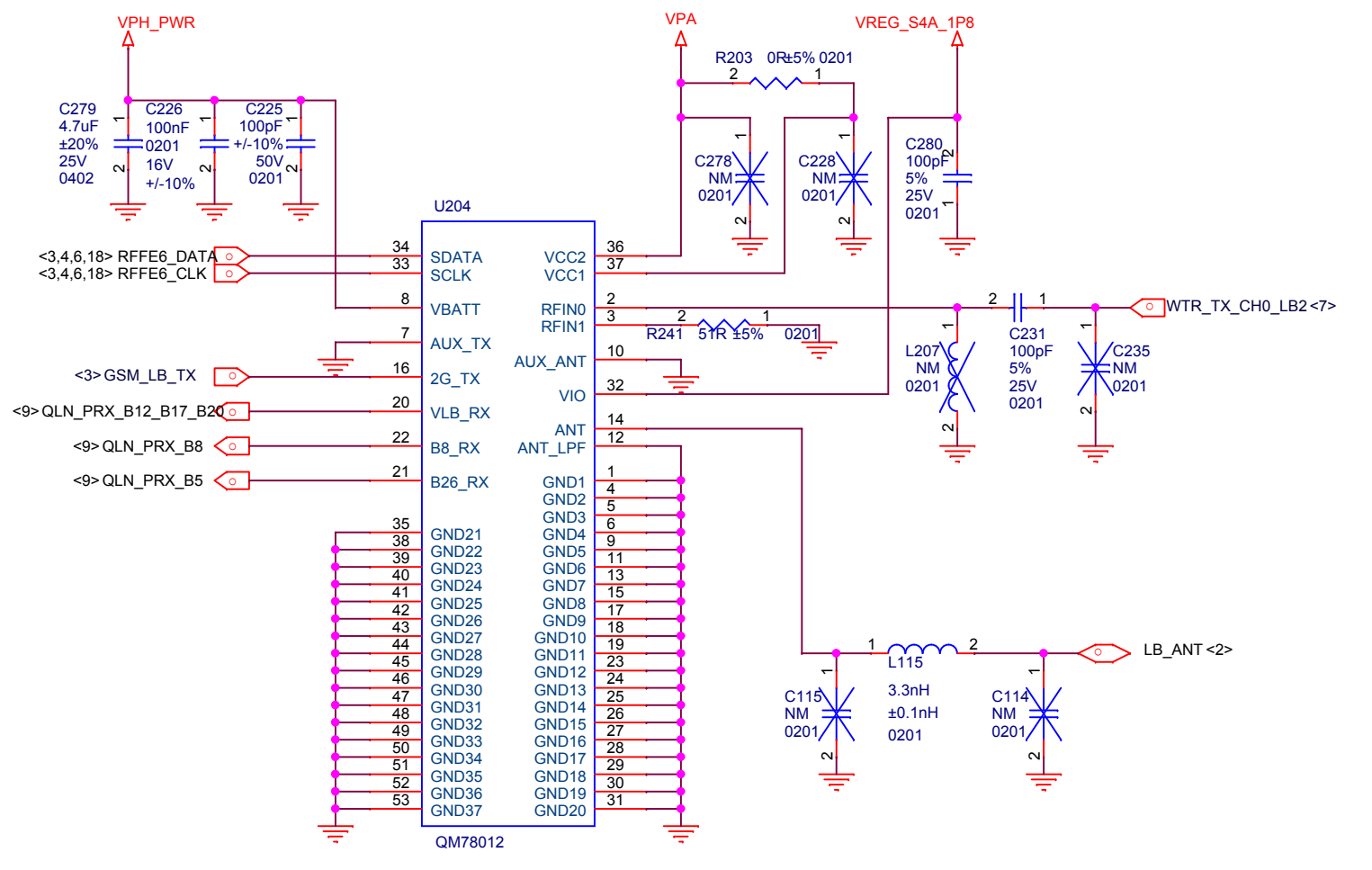

Confidential

MBPA

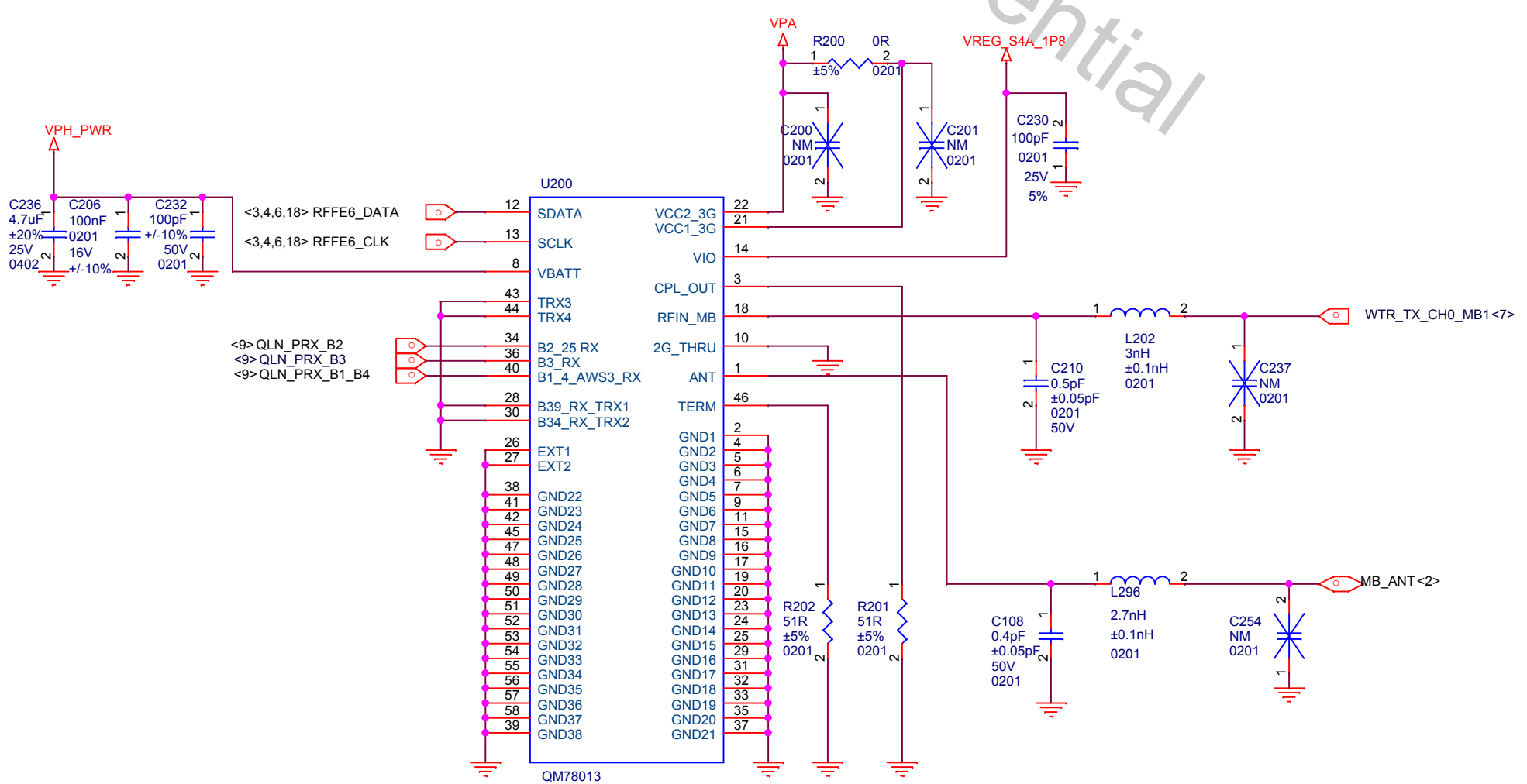

Title		E8	
Size	Document Number	2G&LB&MB PA	
Date:	Friday, March 23, 2018	Sheet	3 of 44

HBPA

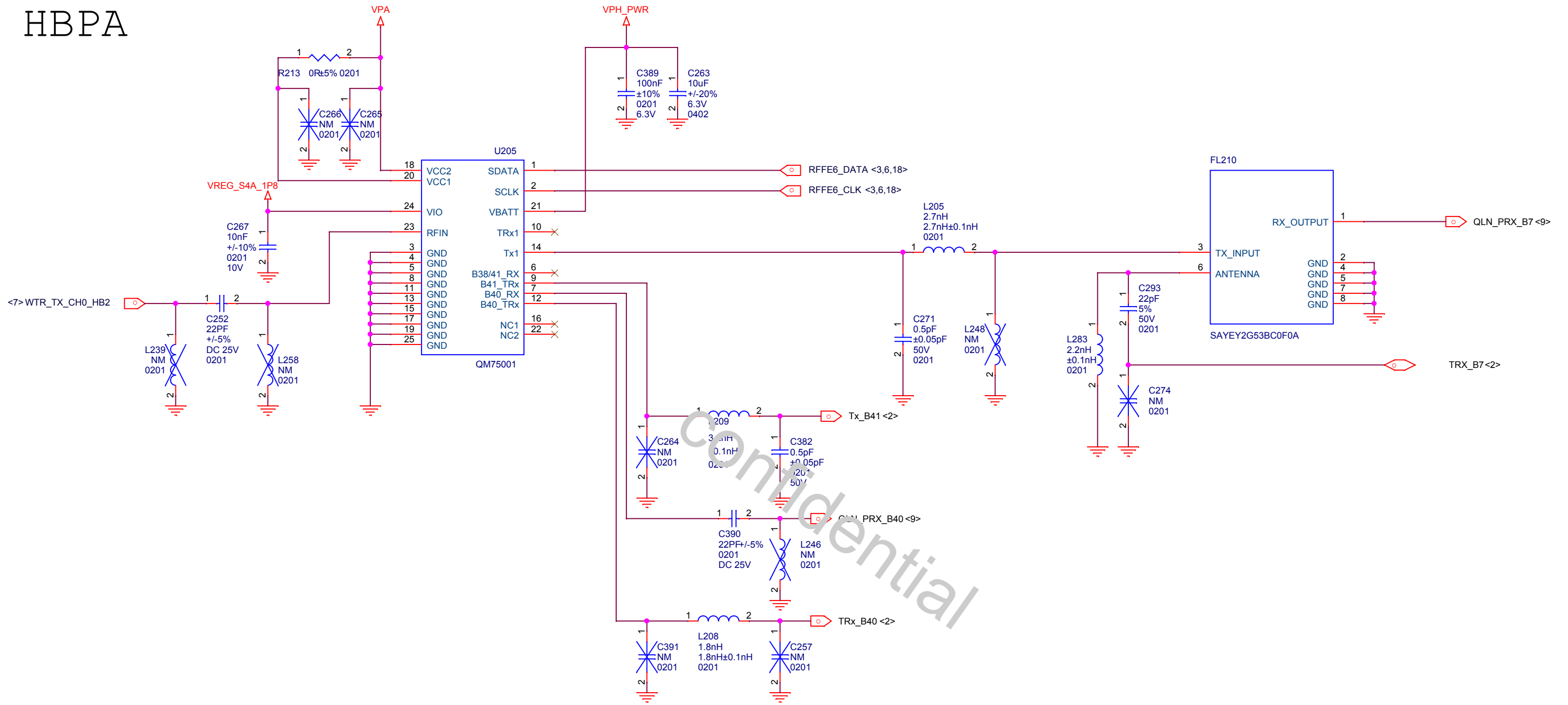

PA THERM



Title		E1	
Size	Document Number	HBPA & PA THERM	
A3			P0
Date:	Friday, March 23, 2018	Sheet	4 of 44

PRX B34 B39 B41

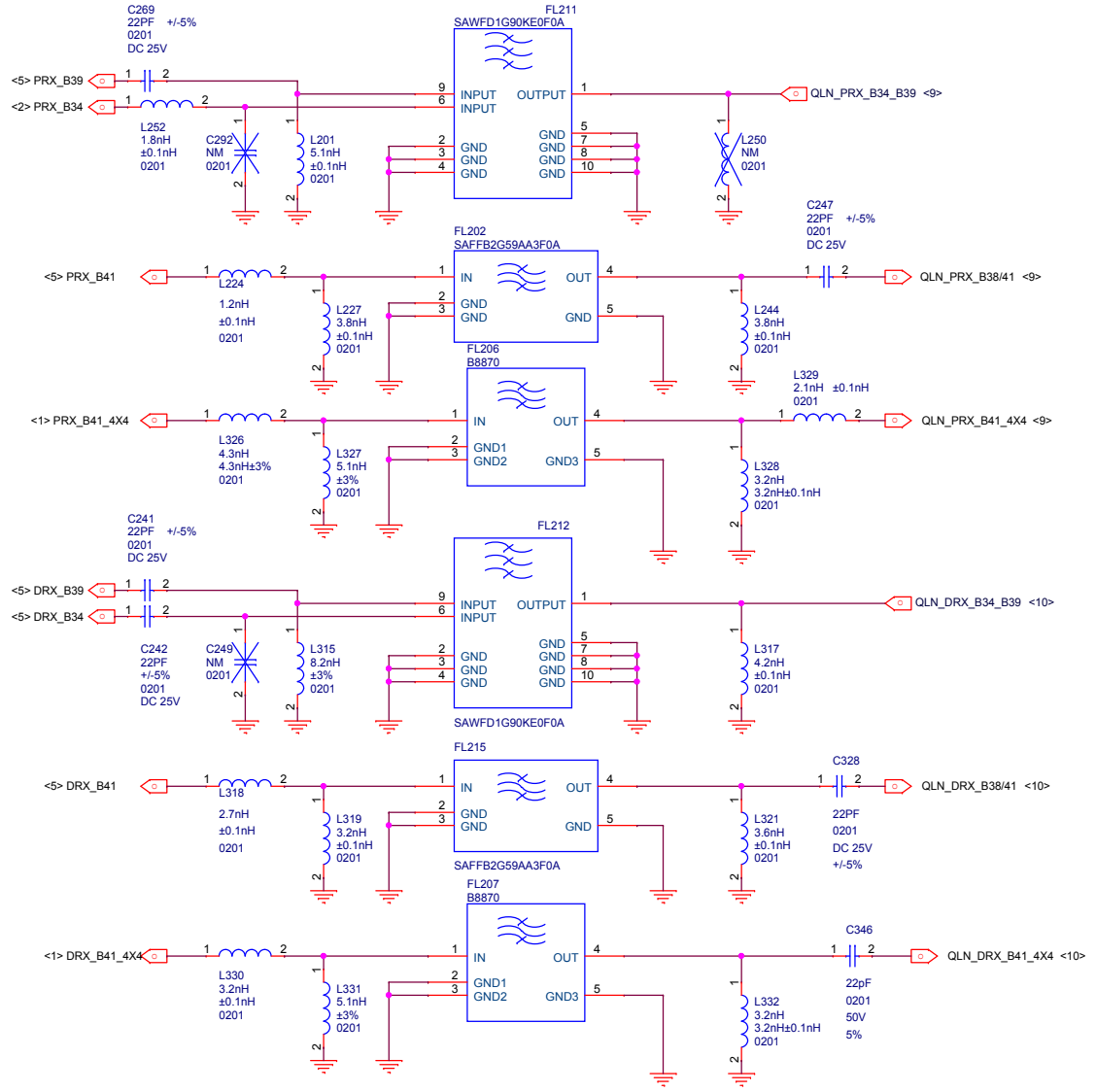

DIPLEXER B39 B41

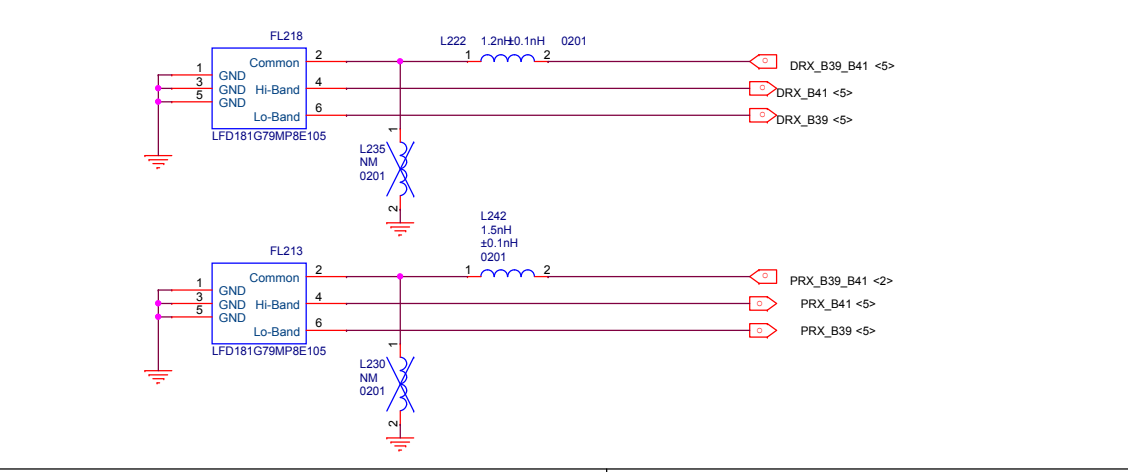

DRX

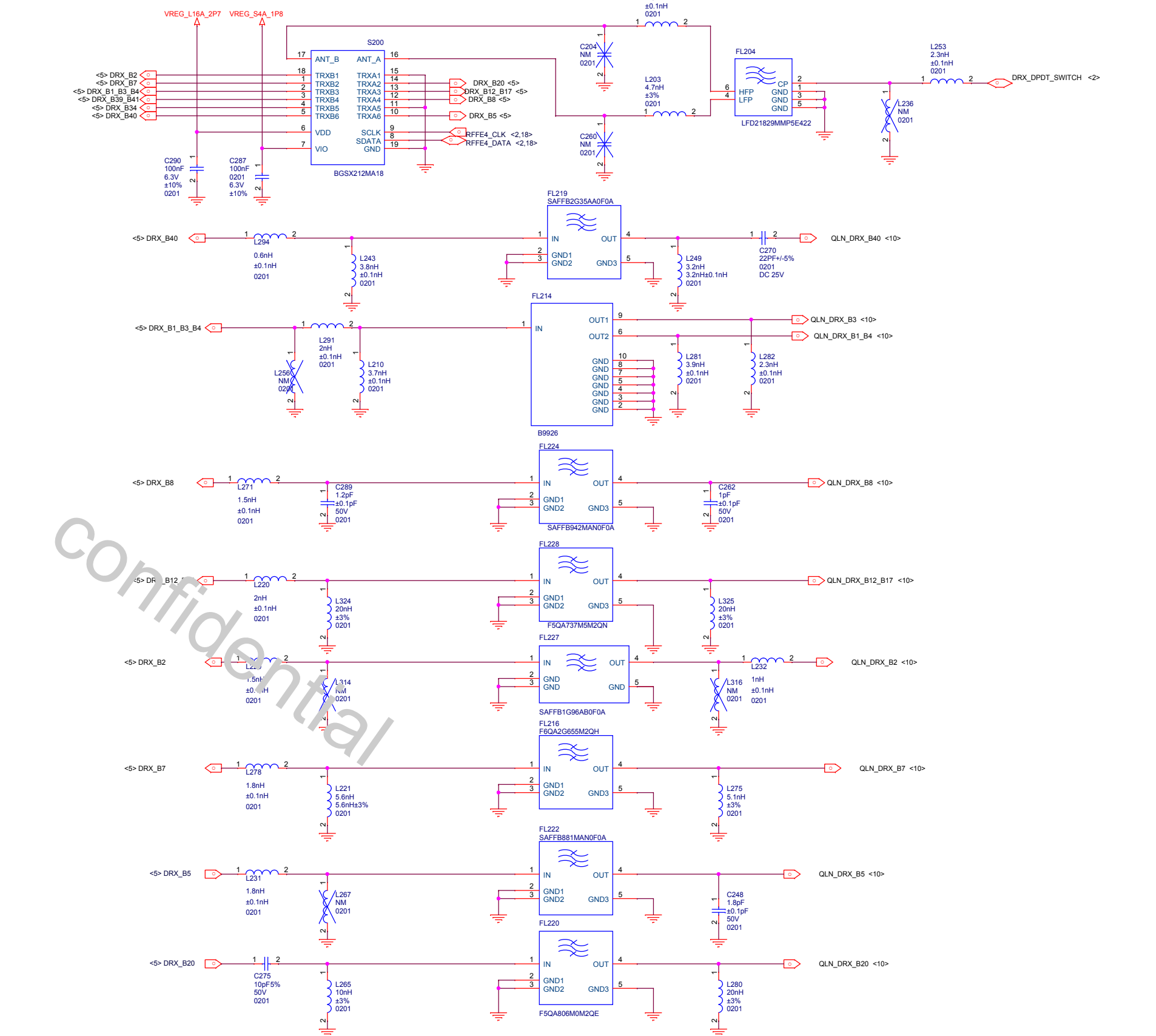

Confidential

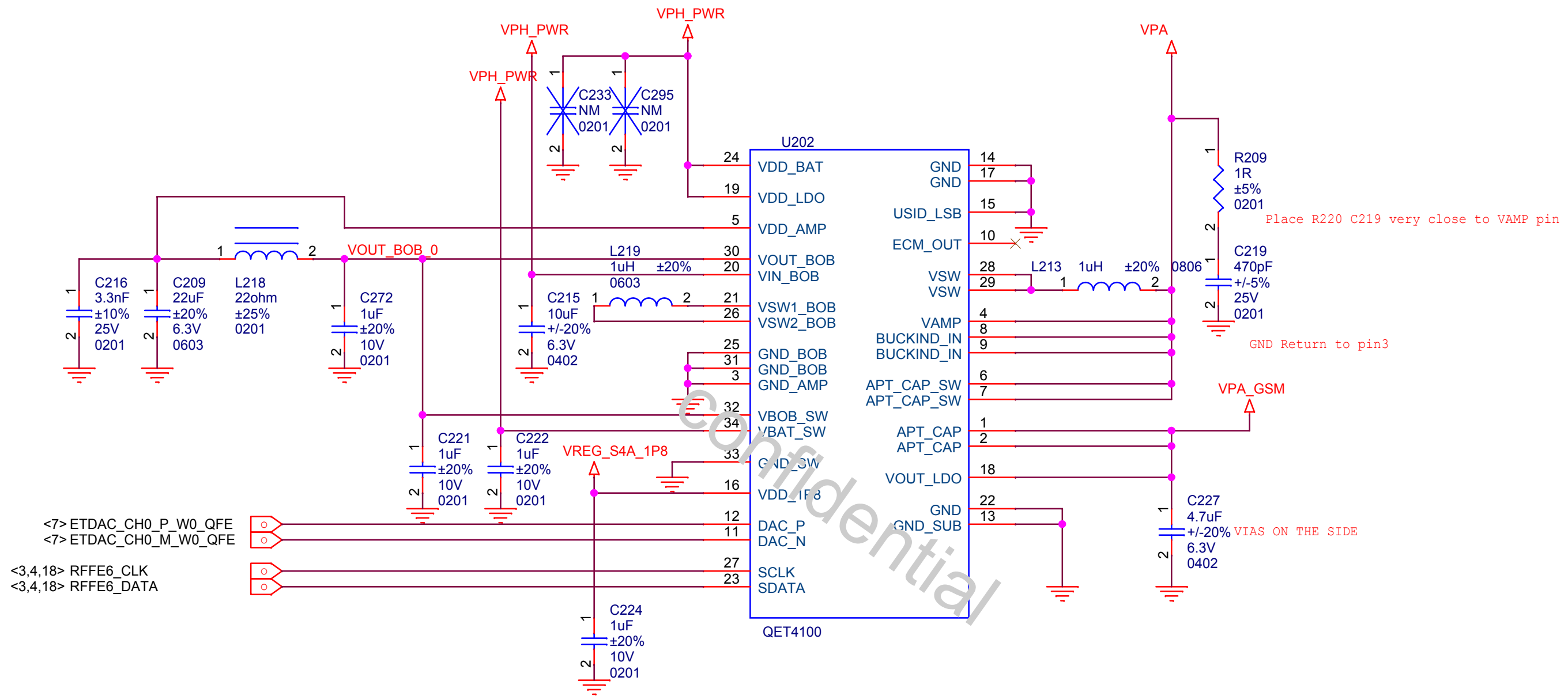

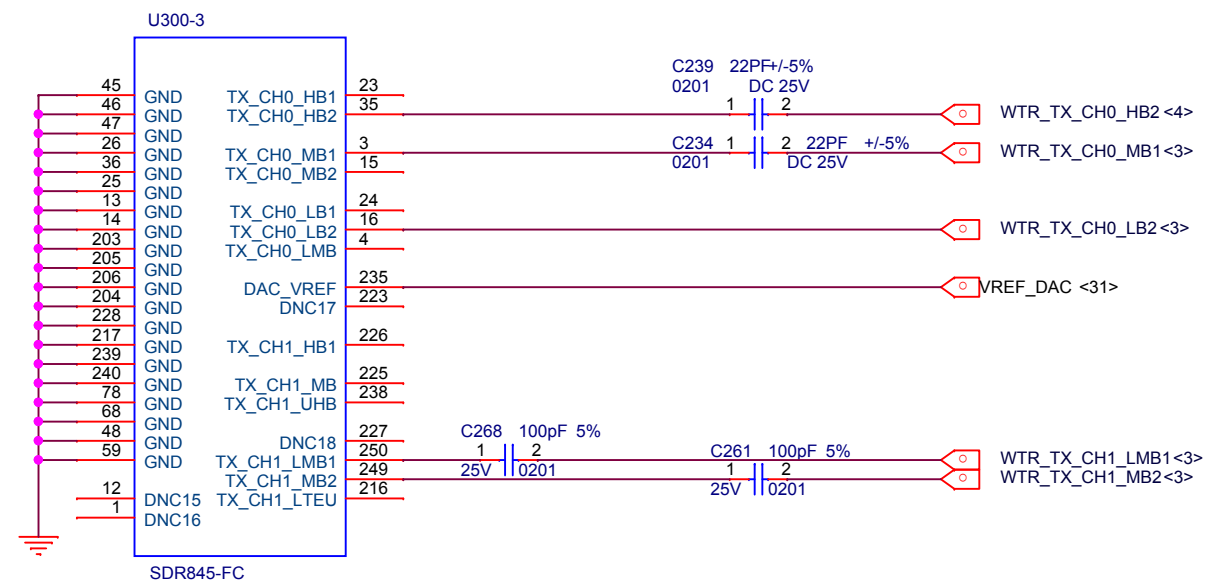
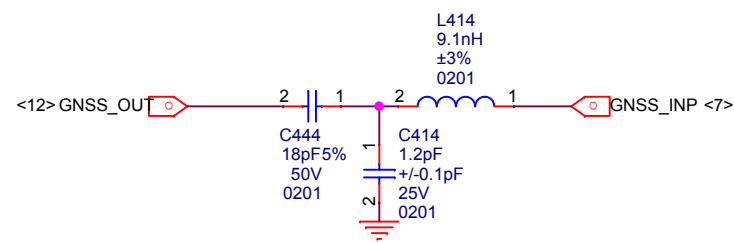
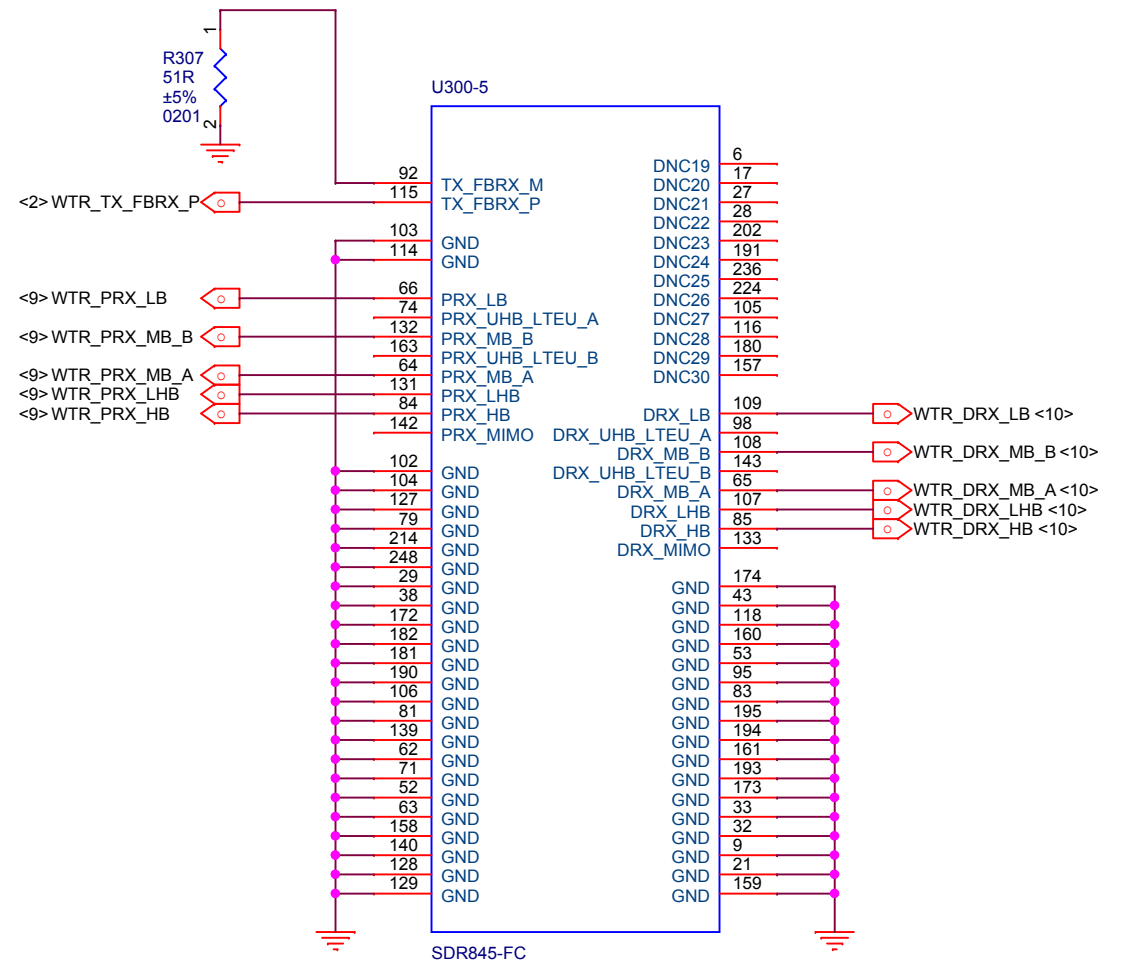
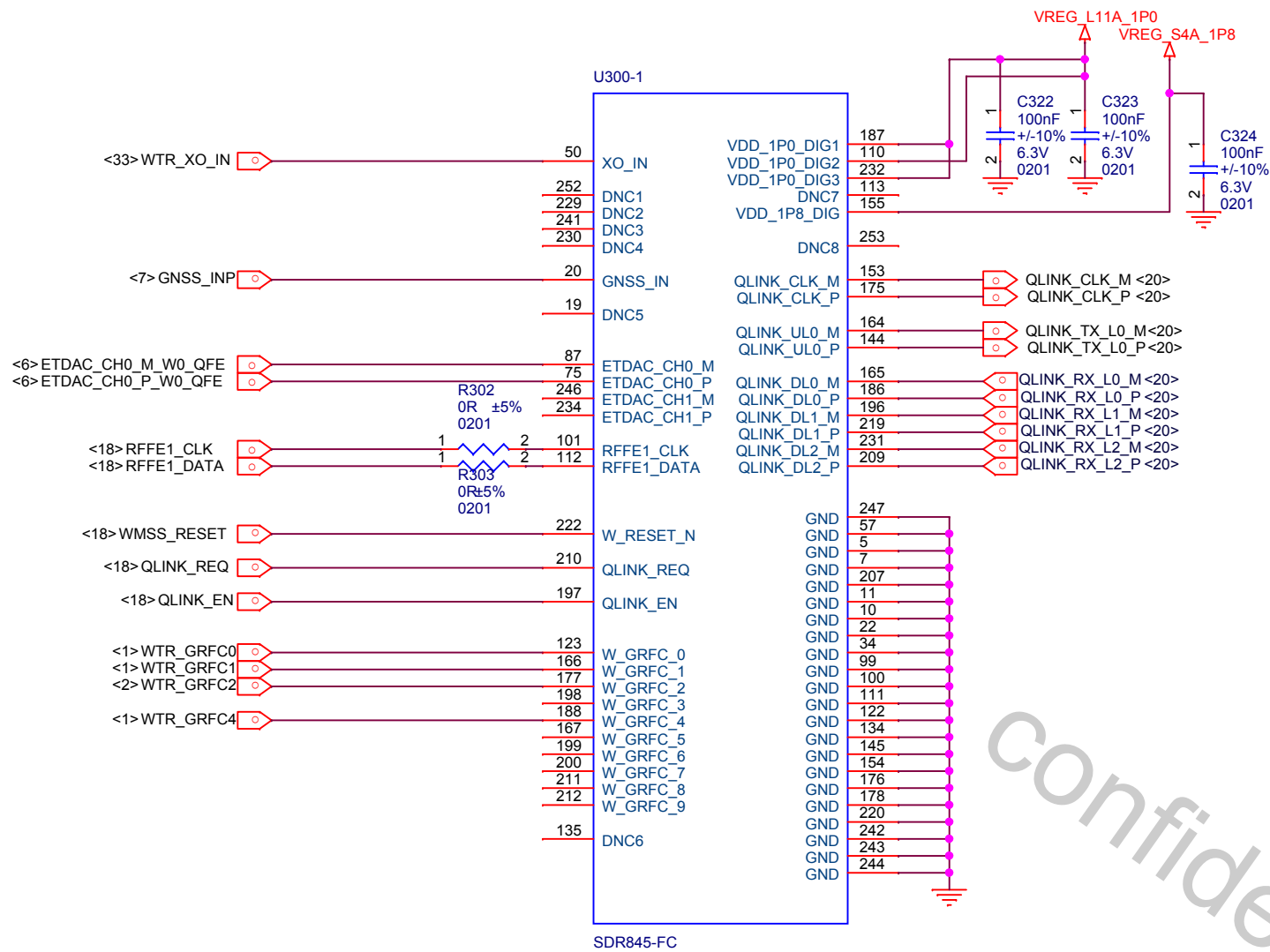

confidential

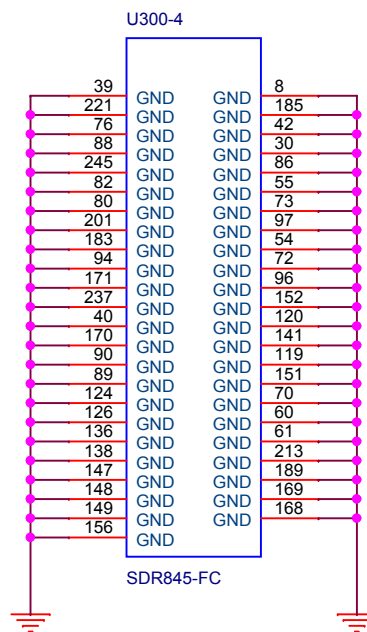
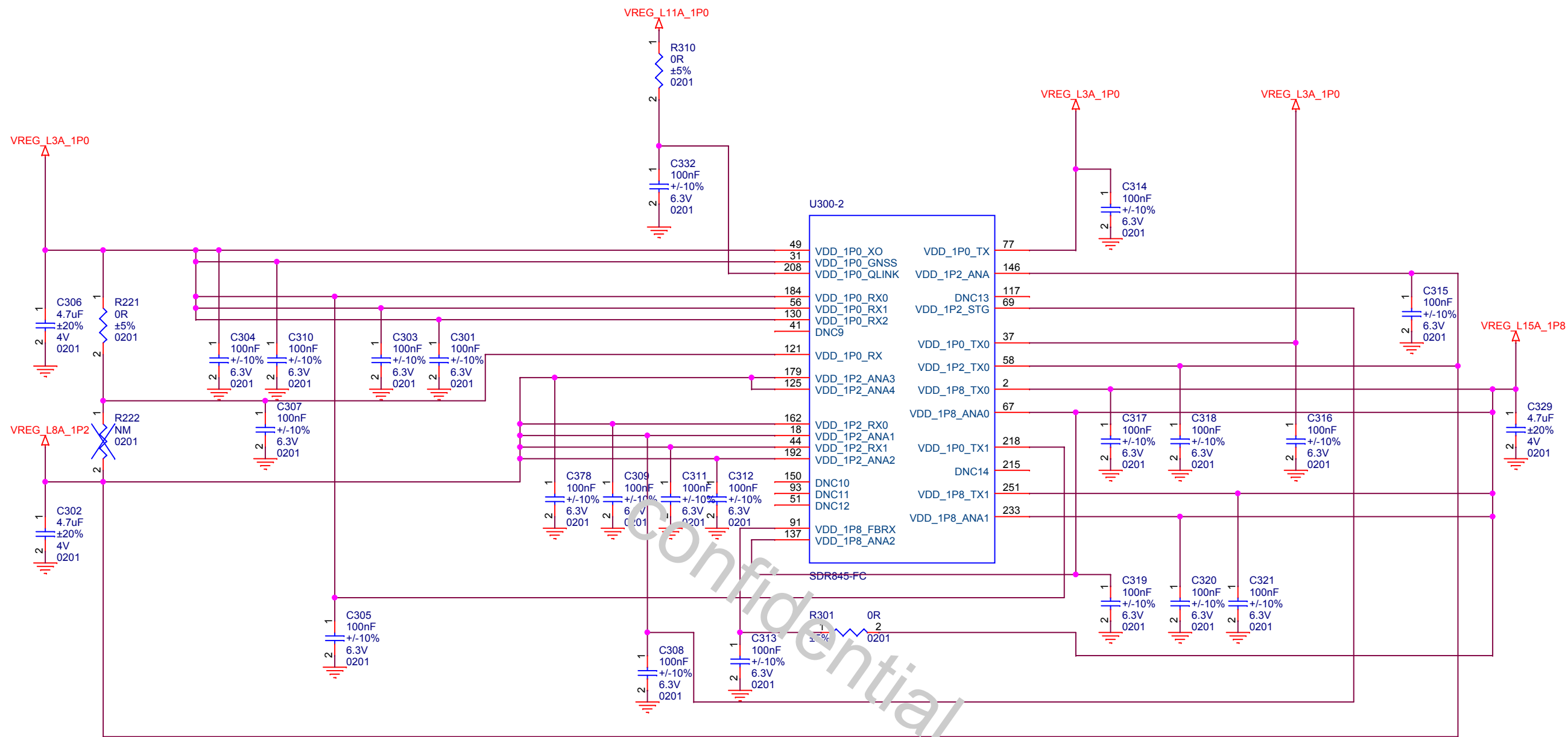

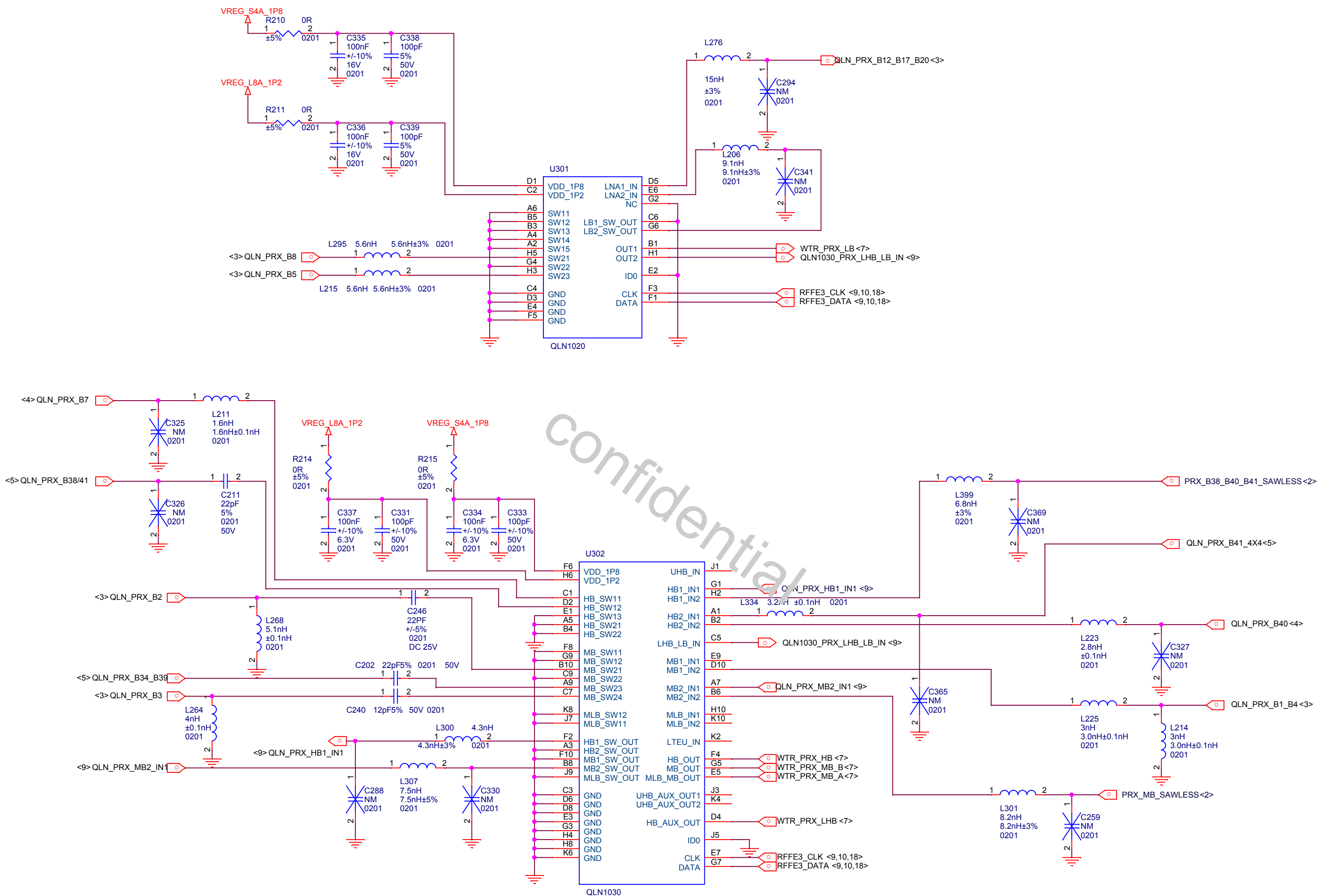

Confidential

Title		E8		
Size	Document Number	QLN PRX		
A3				P0
Date:	Friday, March 23, 2018	Sheet	9	of 44

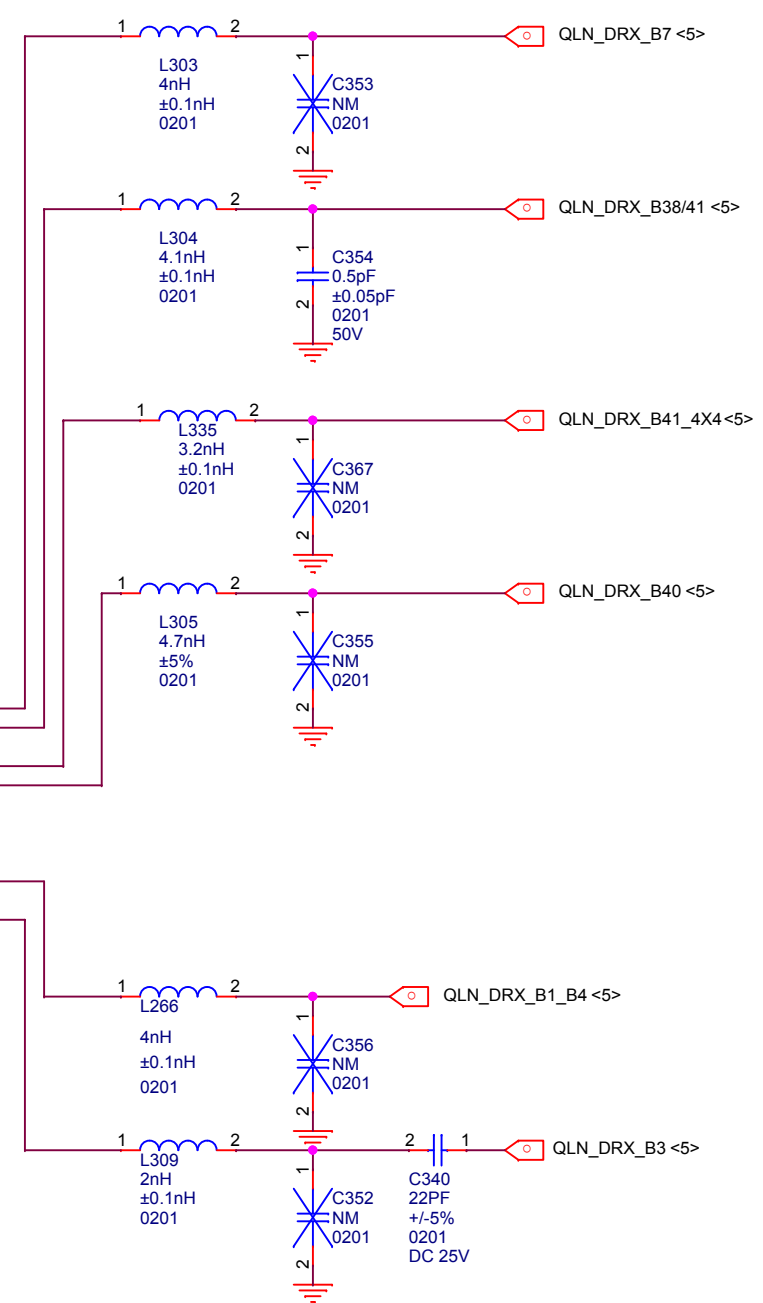
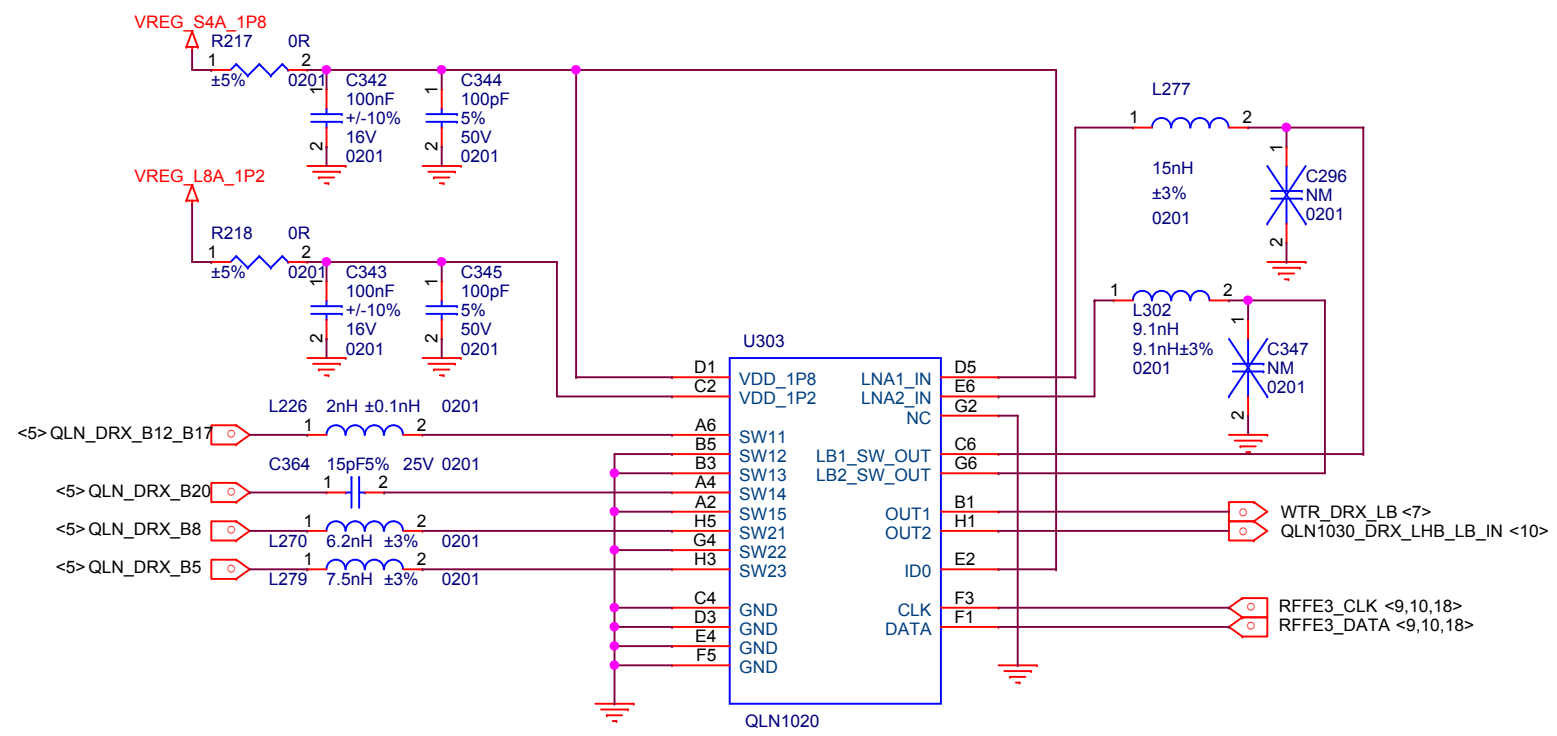

Confidential

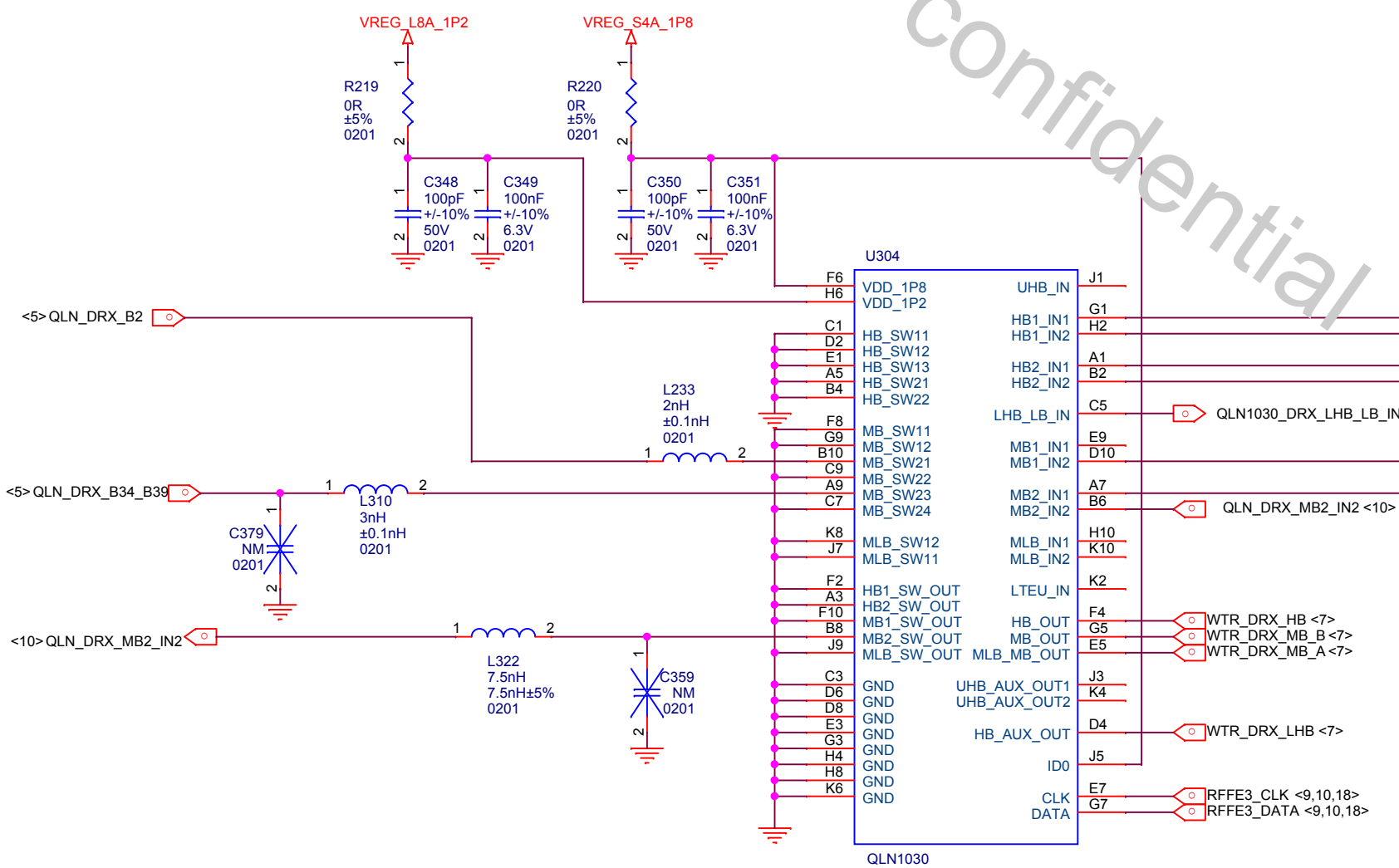

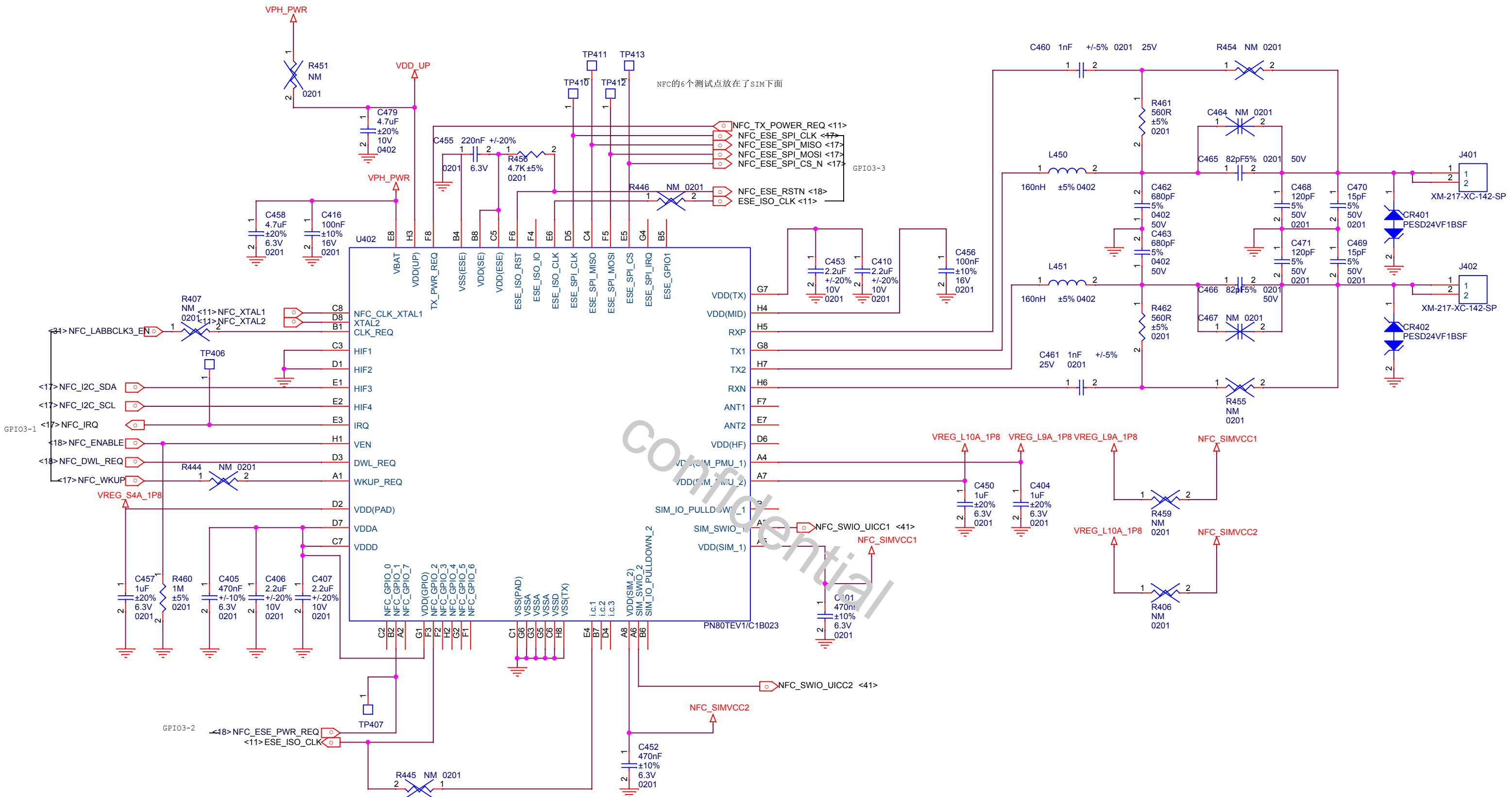

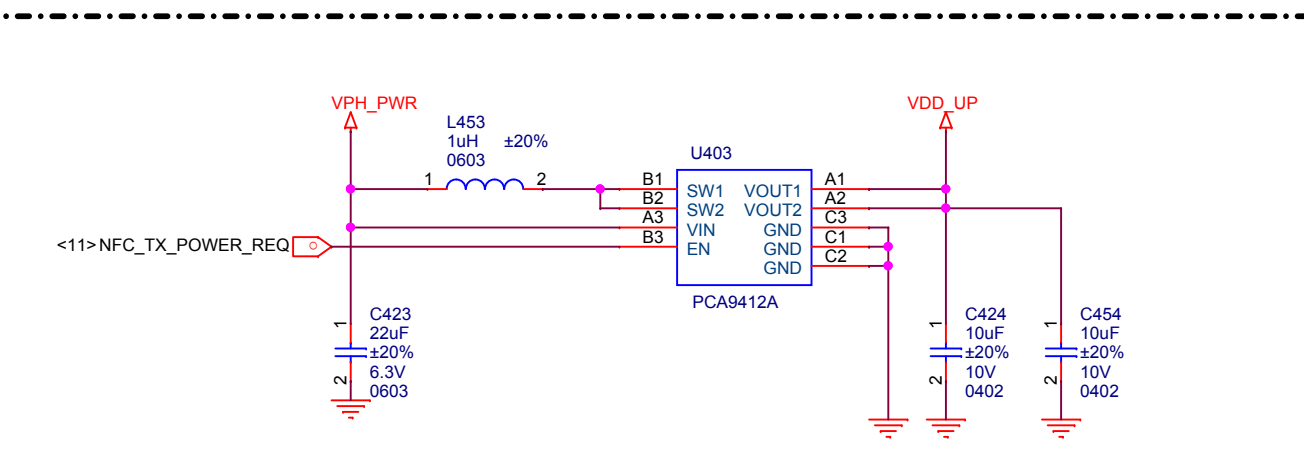
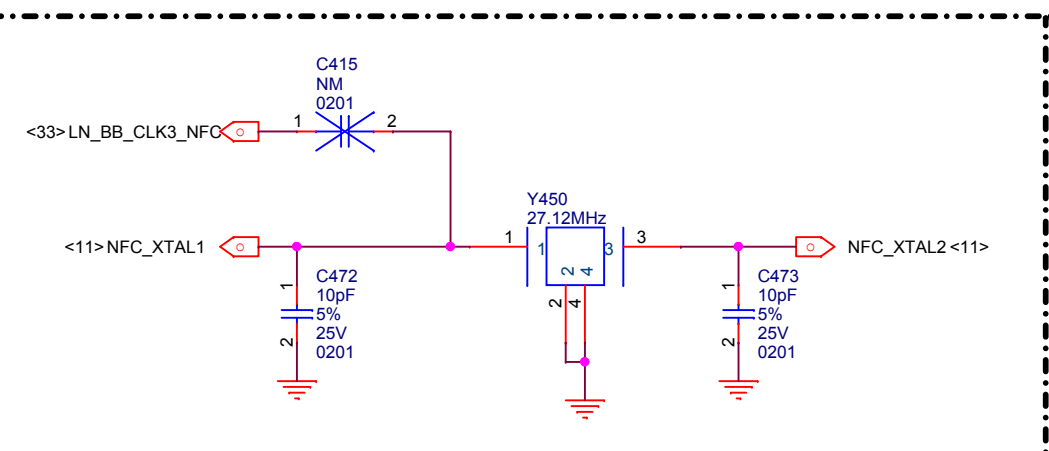

NFC的6个测试点放在了SIM下面

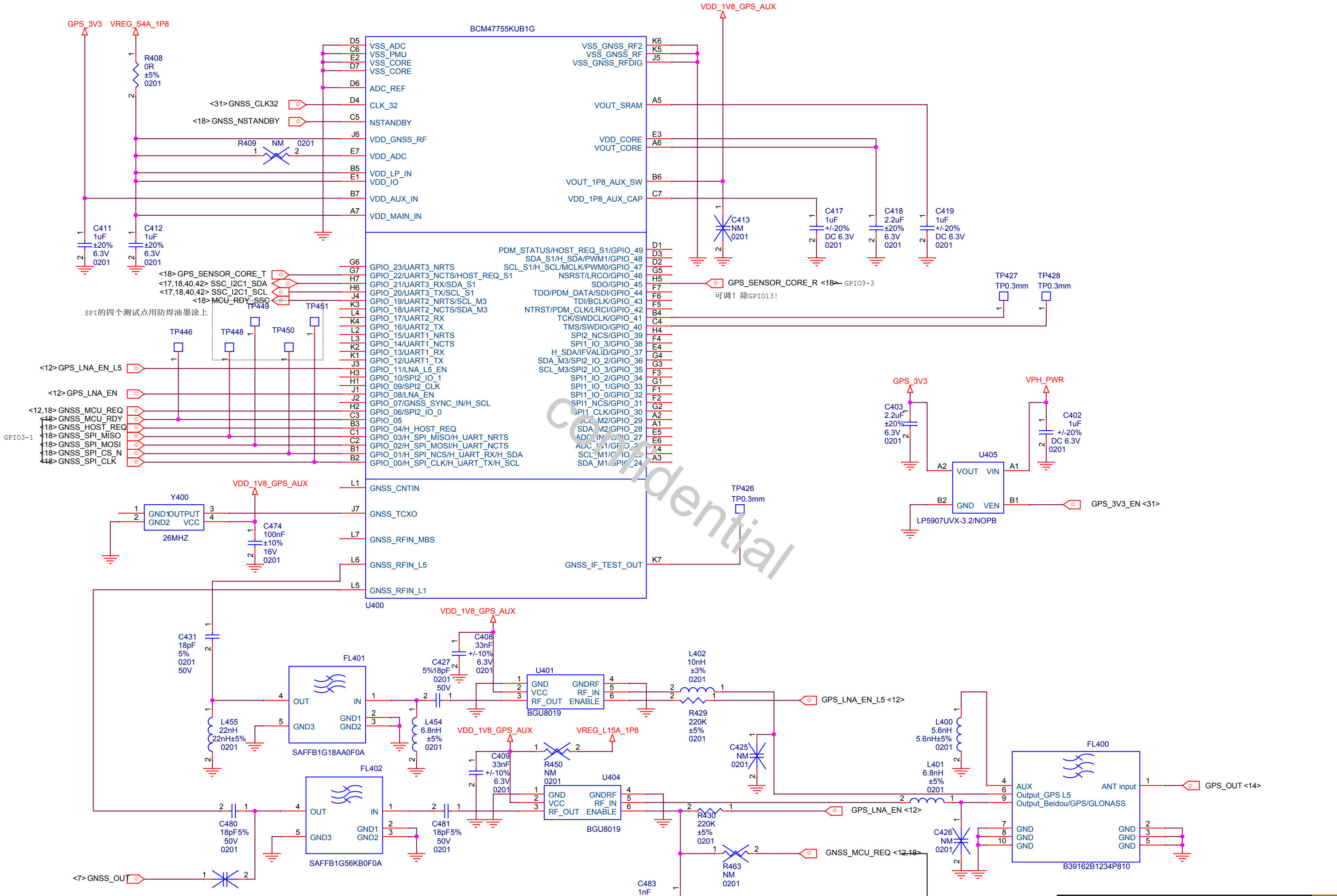

Title		E8	Rev P0
Size	Document Number		
A3	NFC		
Date:	Friday, March 23, 2018	Sheet	11 of 44



Title		E8	
Size	Document Number	Dual-band GPS	
Date:	Friday, March 23, 2018	Sheet 12 of 44	Rev P0

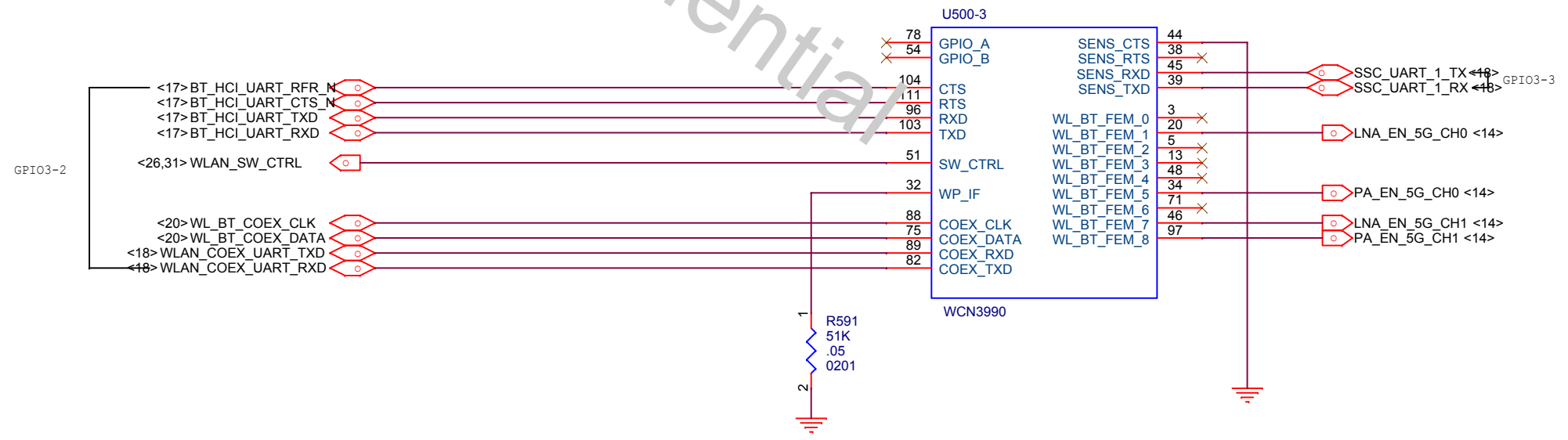
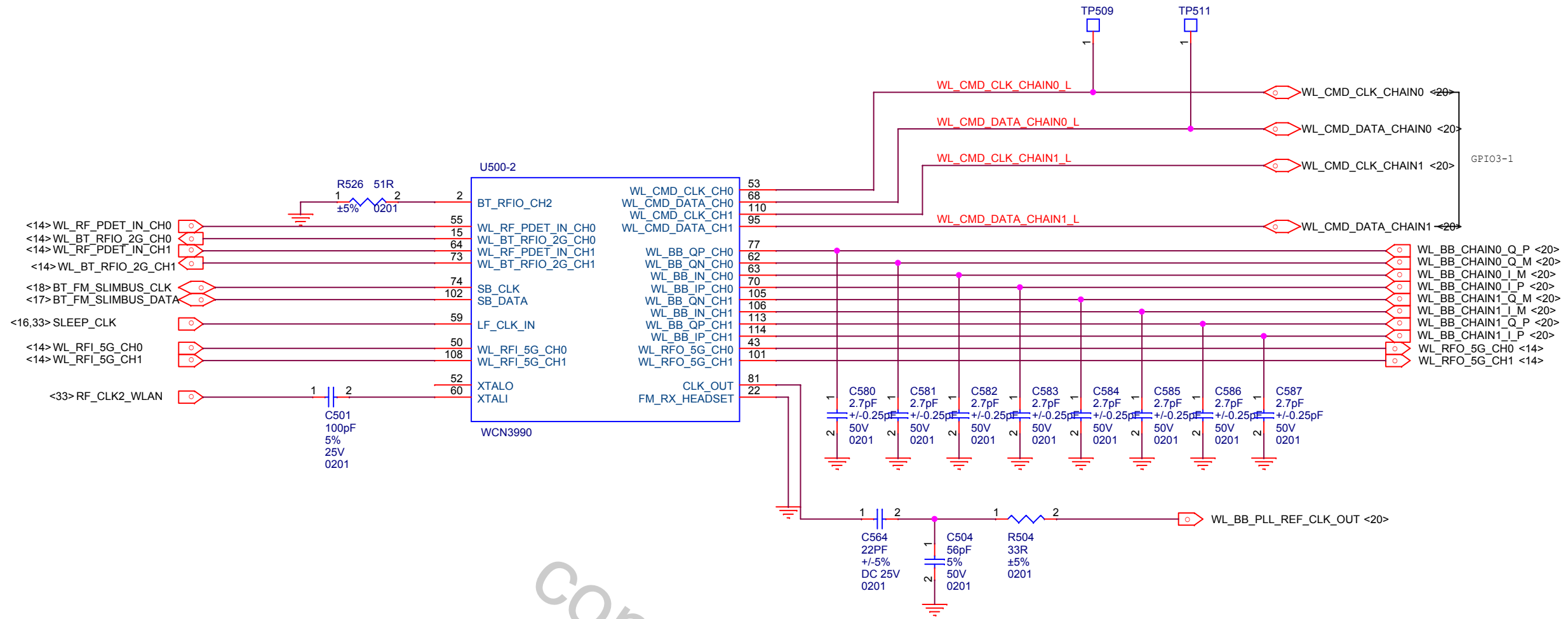

Confidential

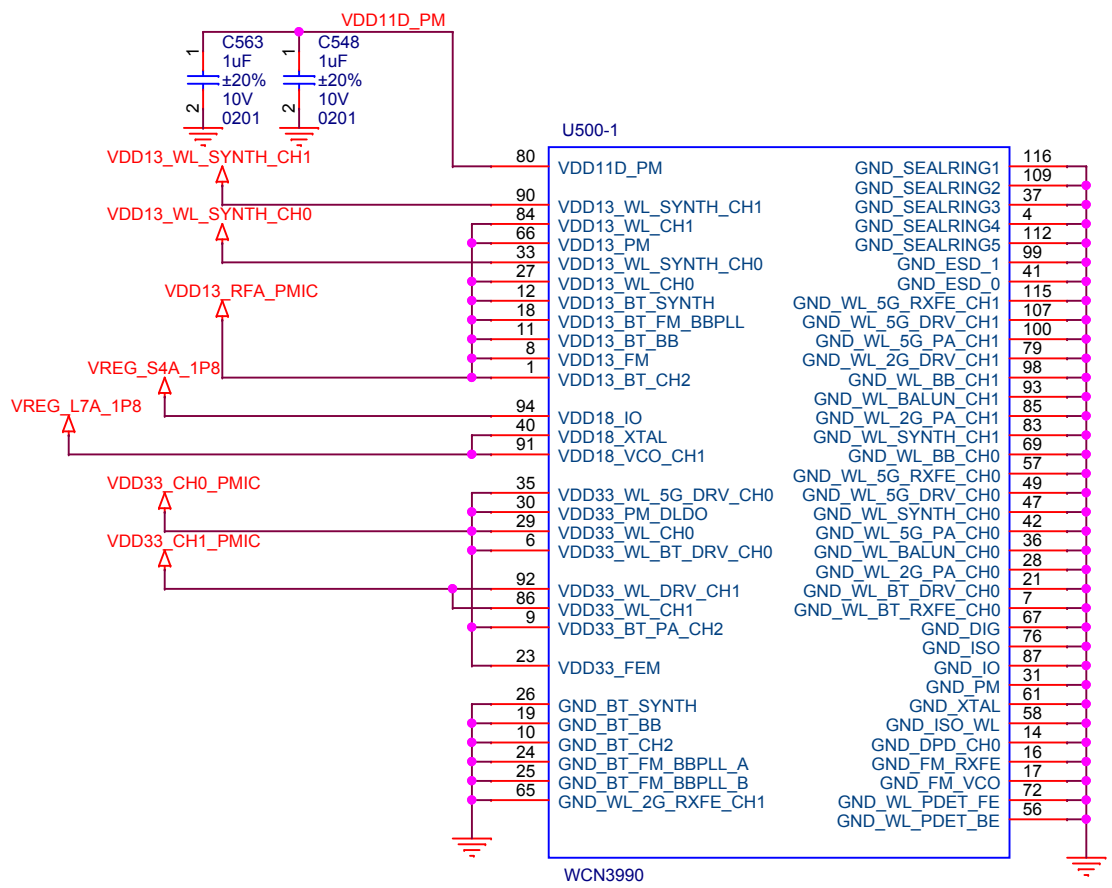
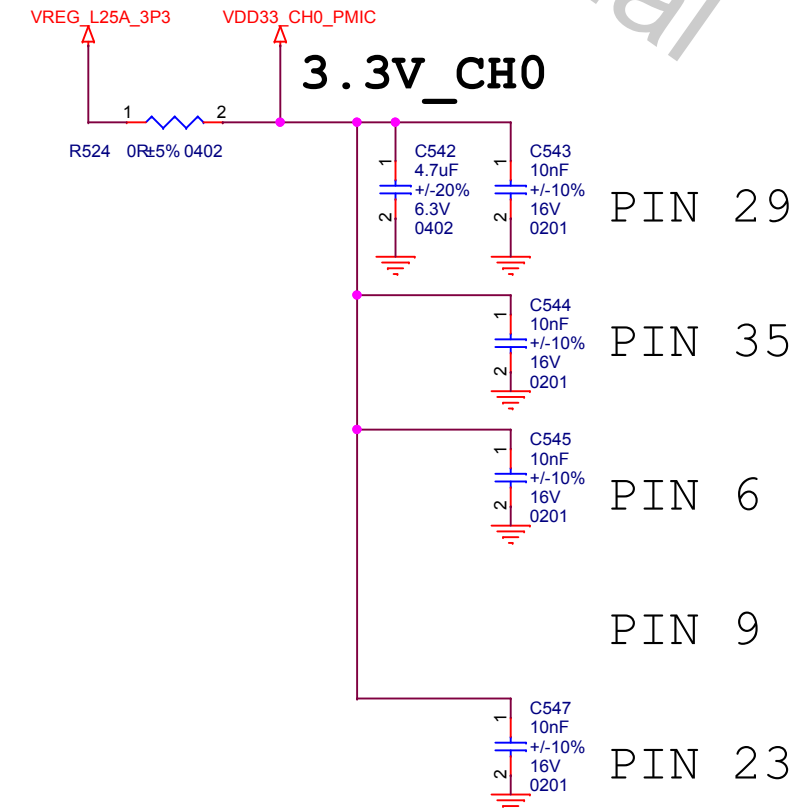
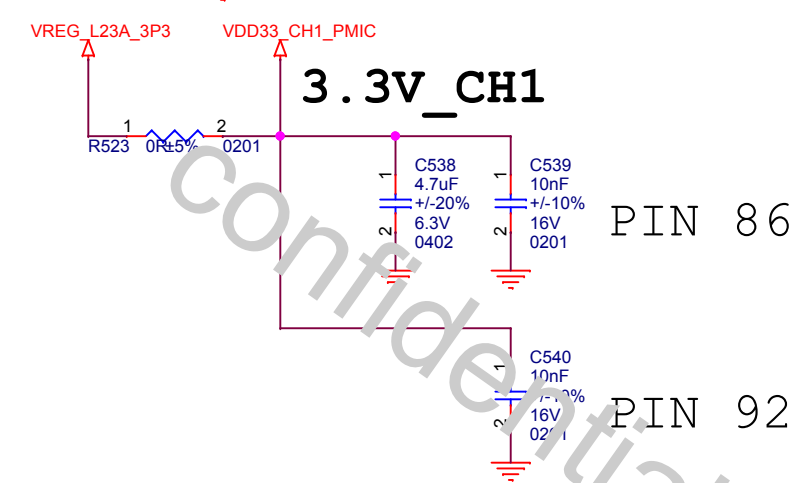
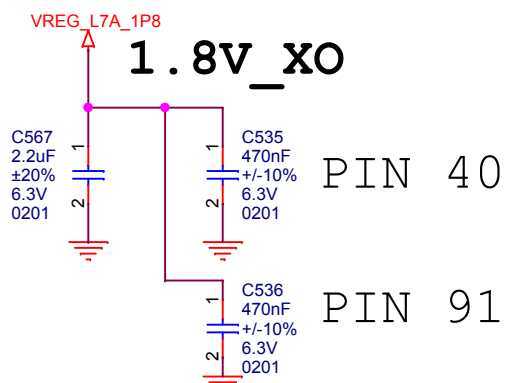
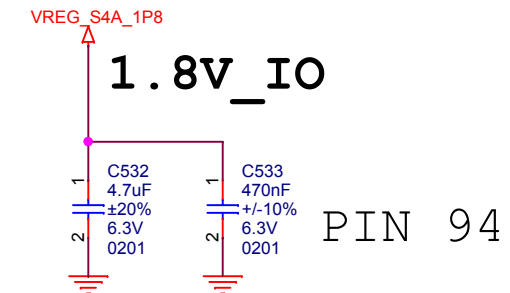
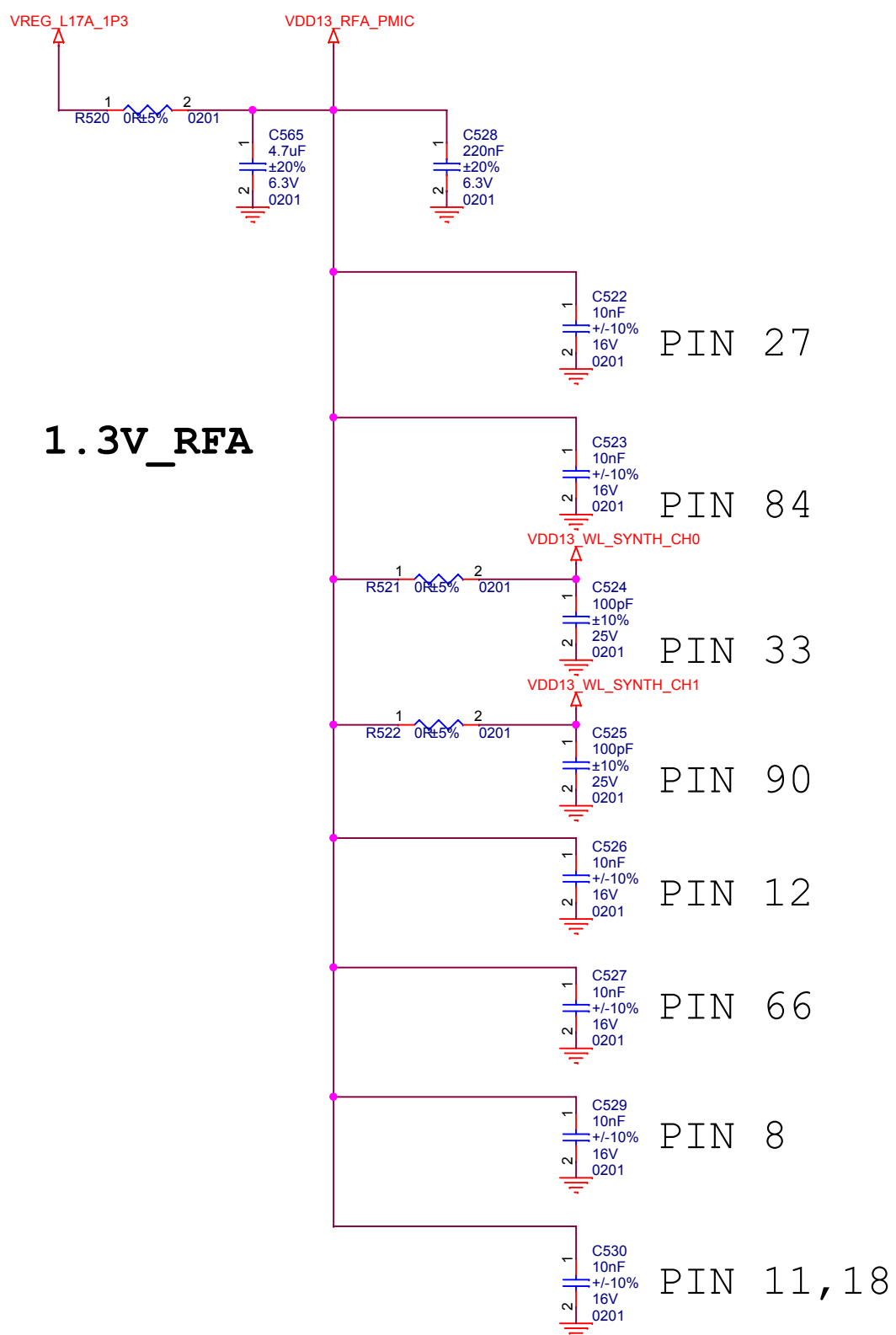

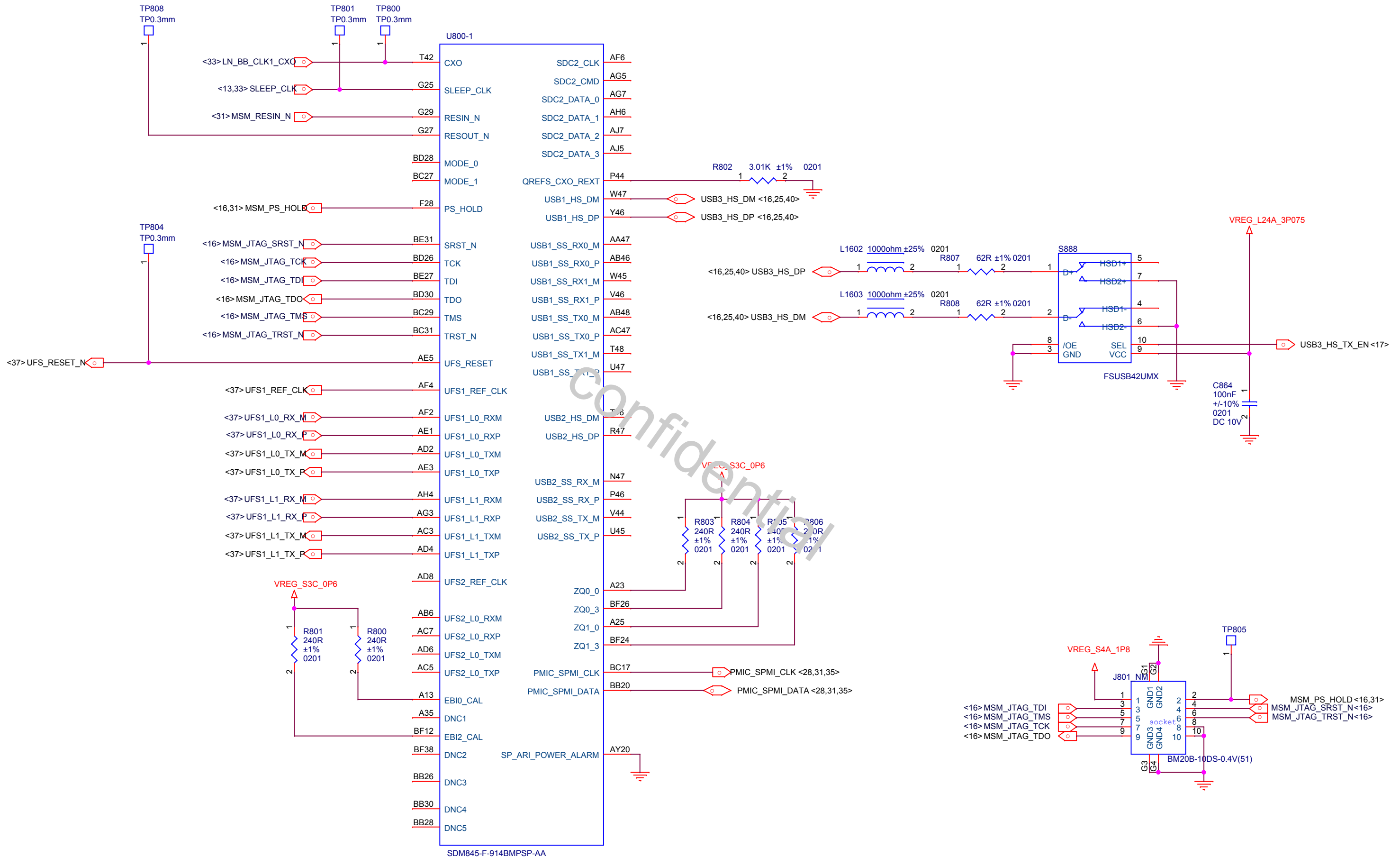

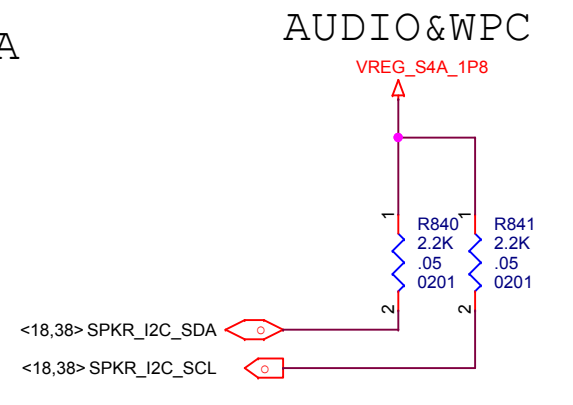
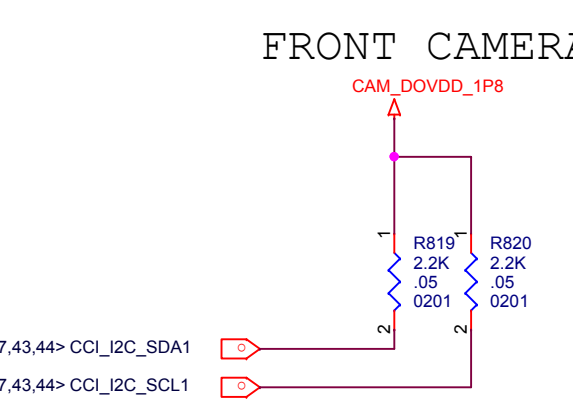
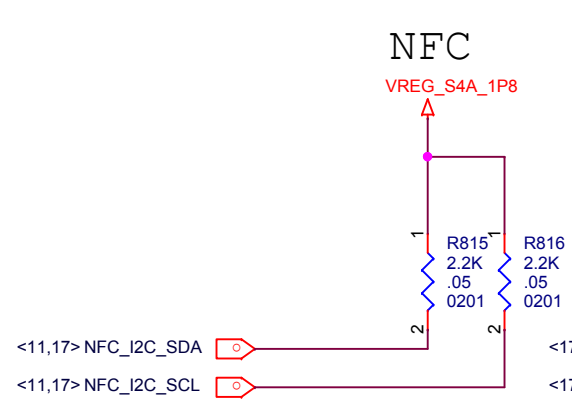
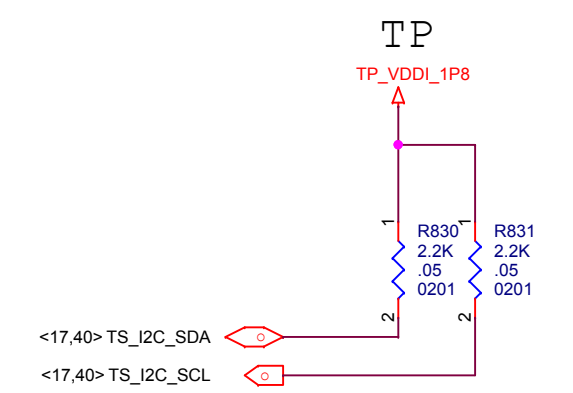
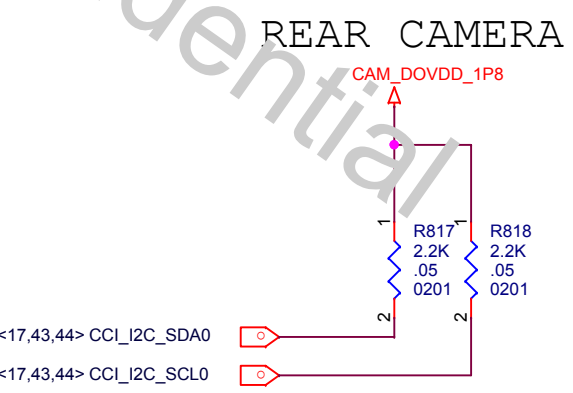
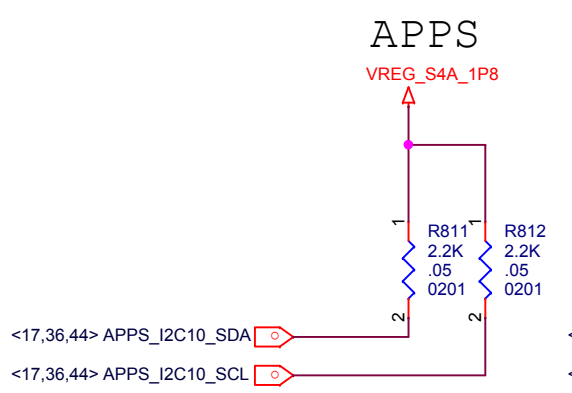
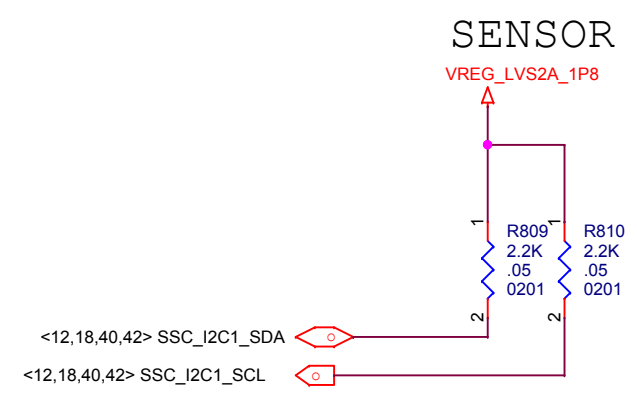
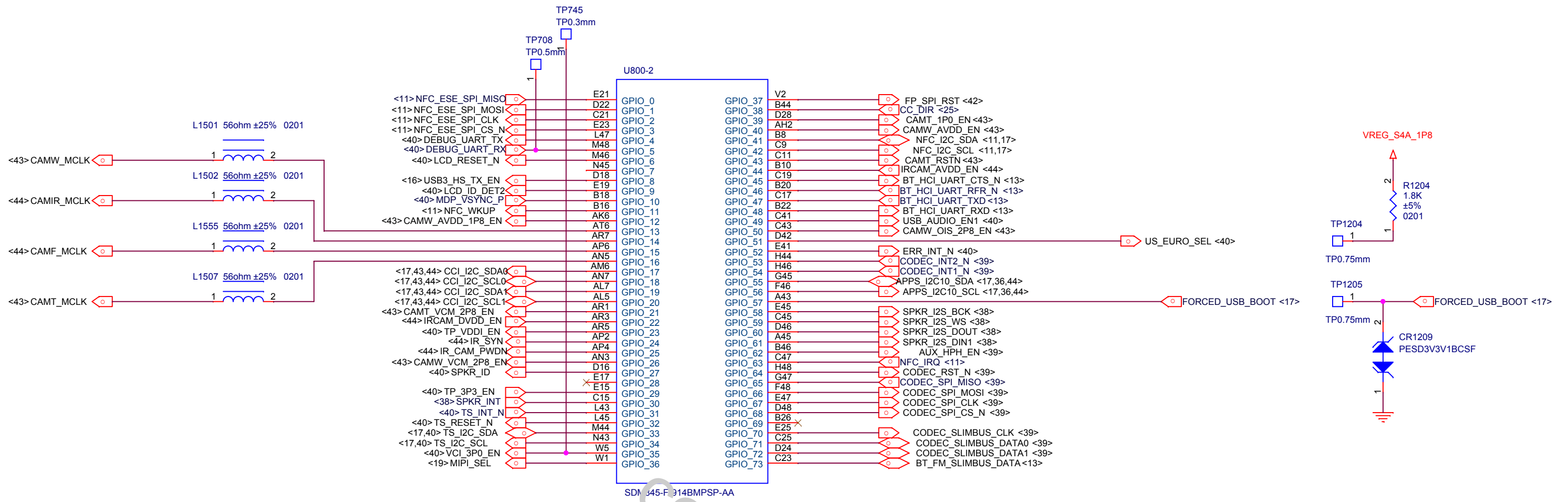

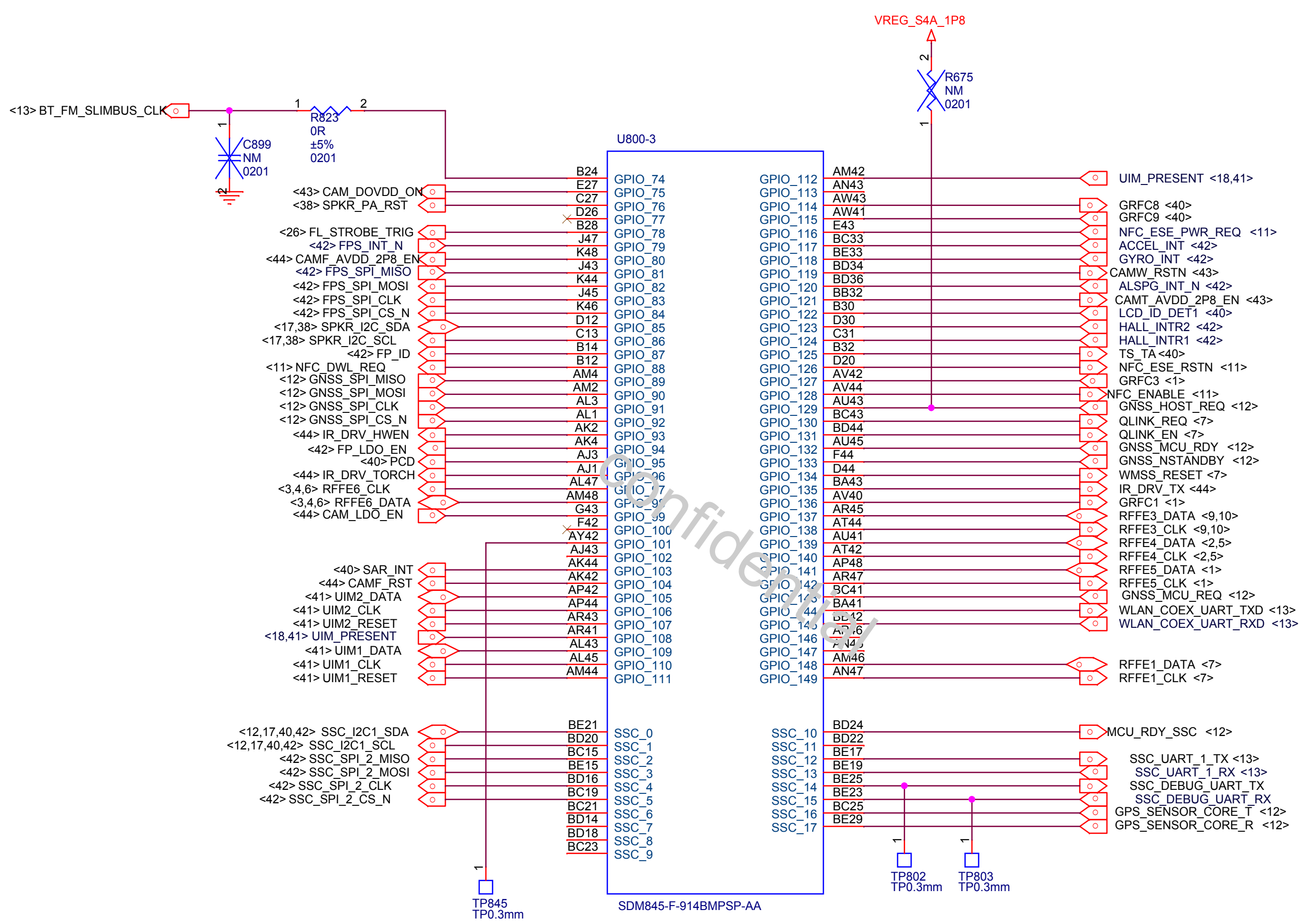

REAR CAMERA WIDE

REAR CAMERA TELE

FRONT CAMERA

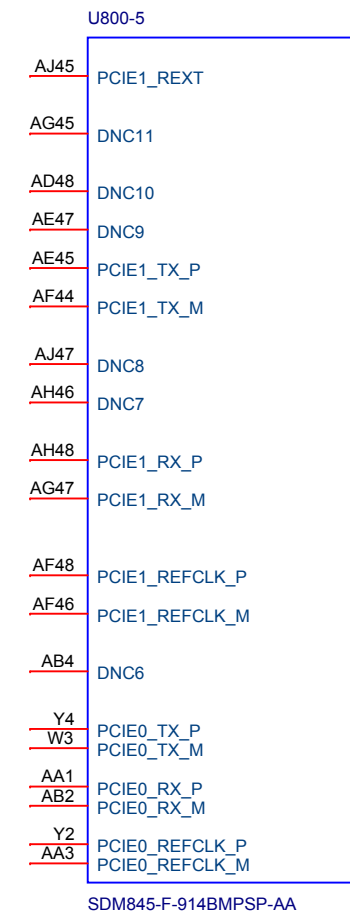
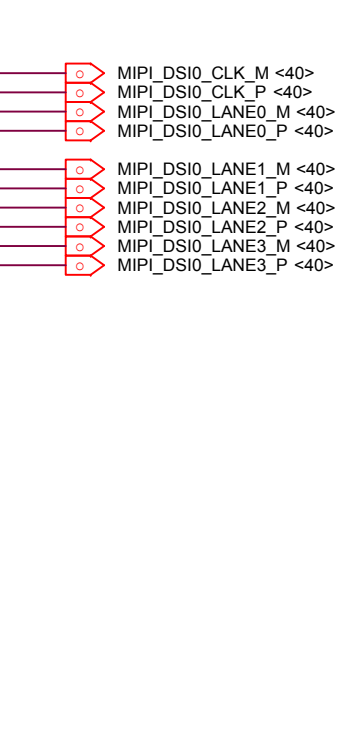
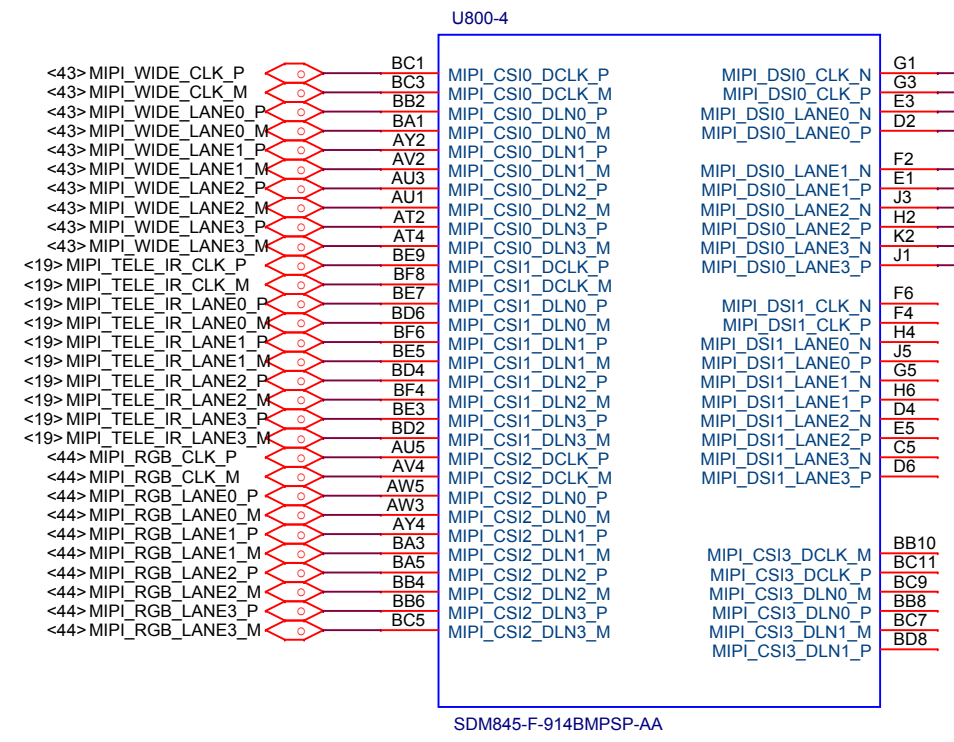

TELE-IR SWITCH

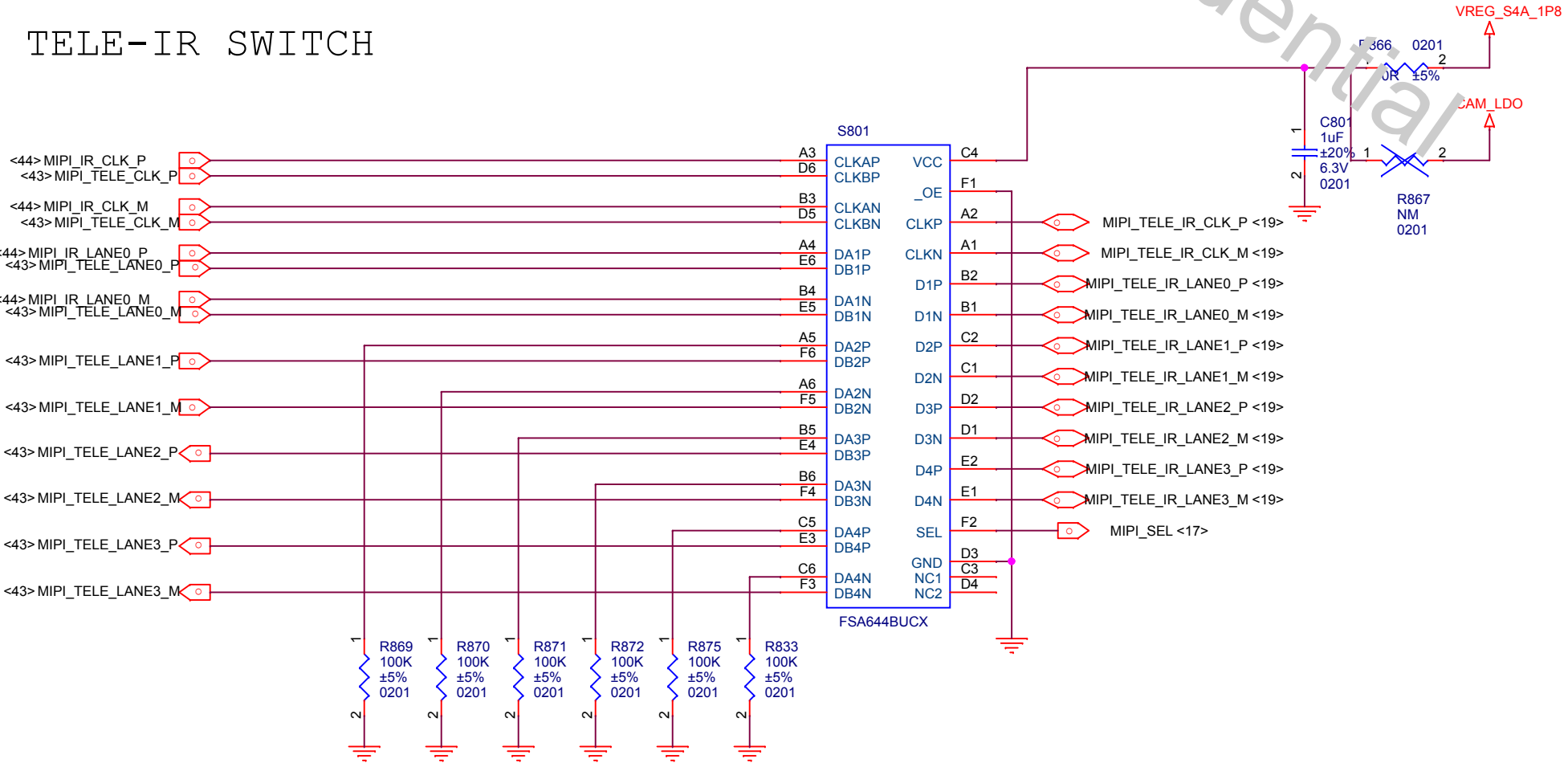

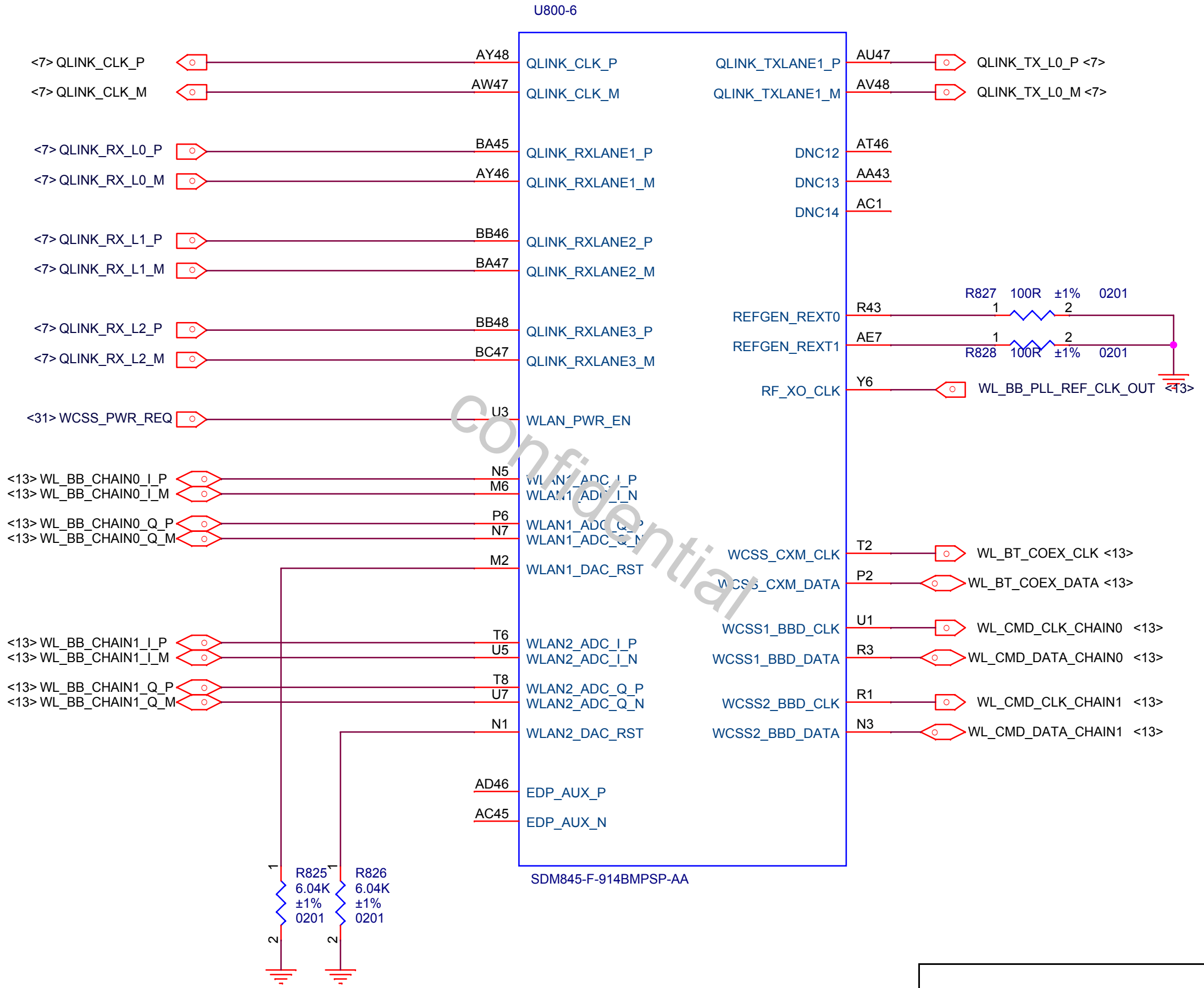

Title		E8		
Size	A4	Document Number	SDM845 RF INTF	
Date:	Friday, March 23, 2018	Sheet	20 of 44	P0

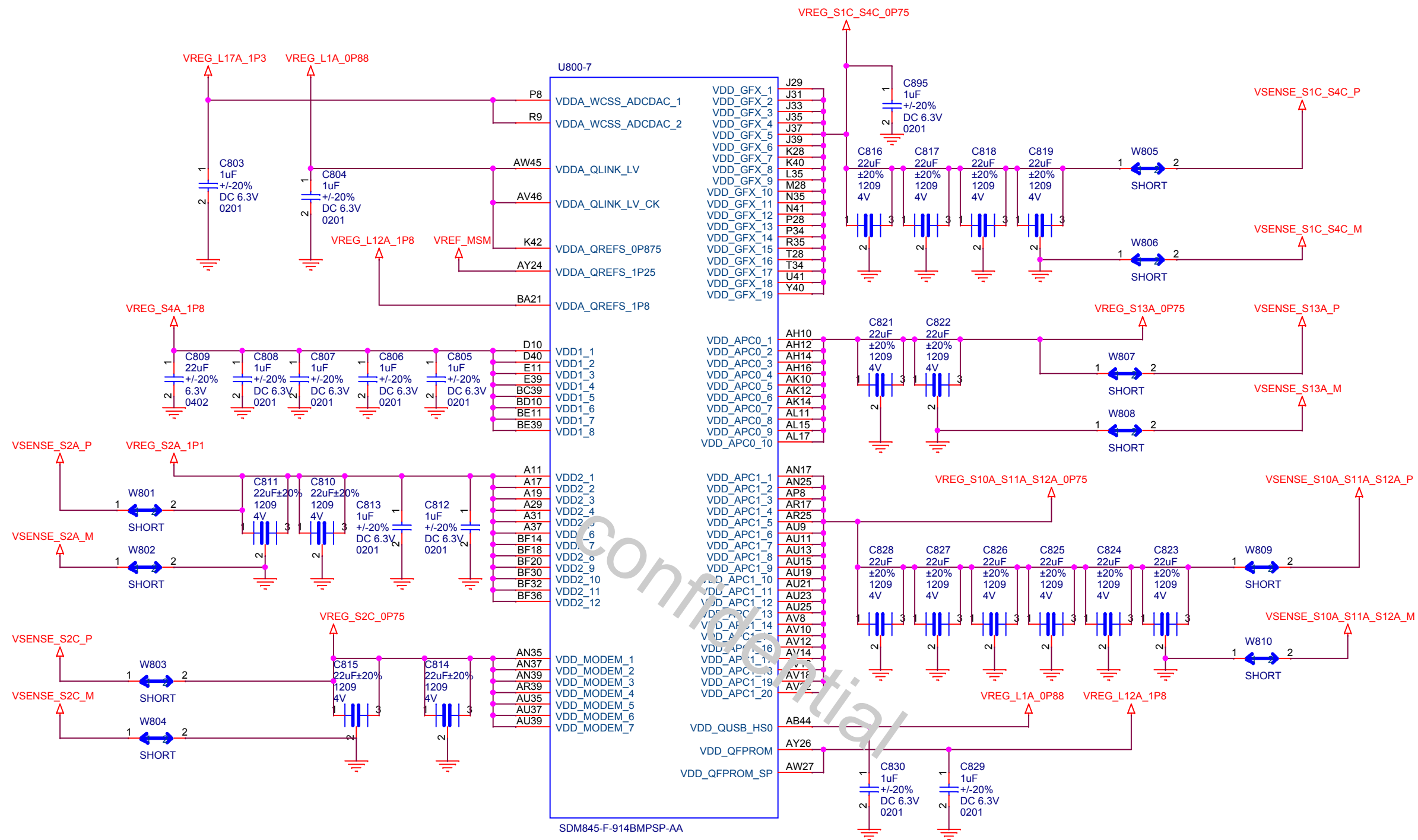

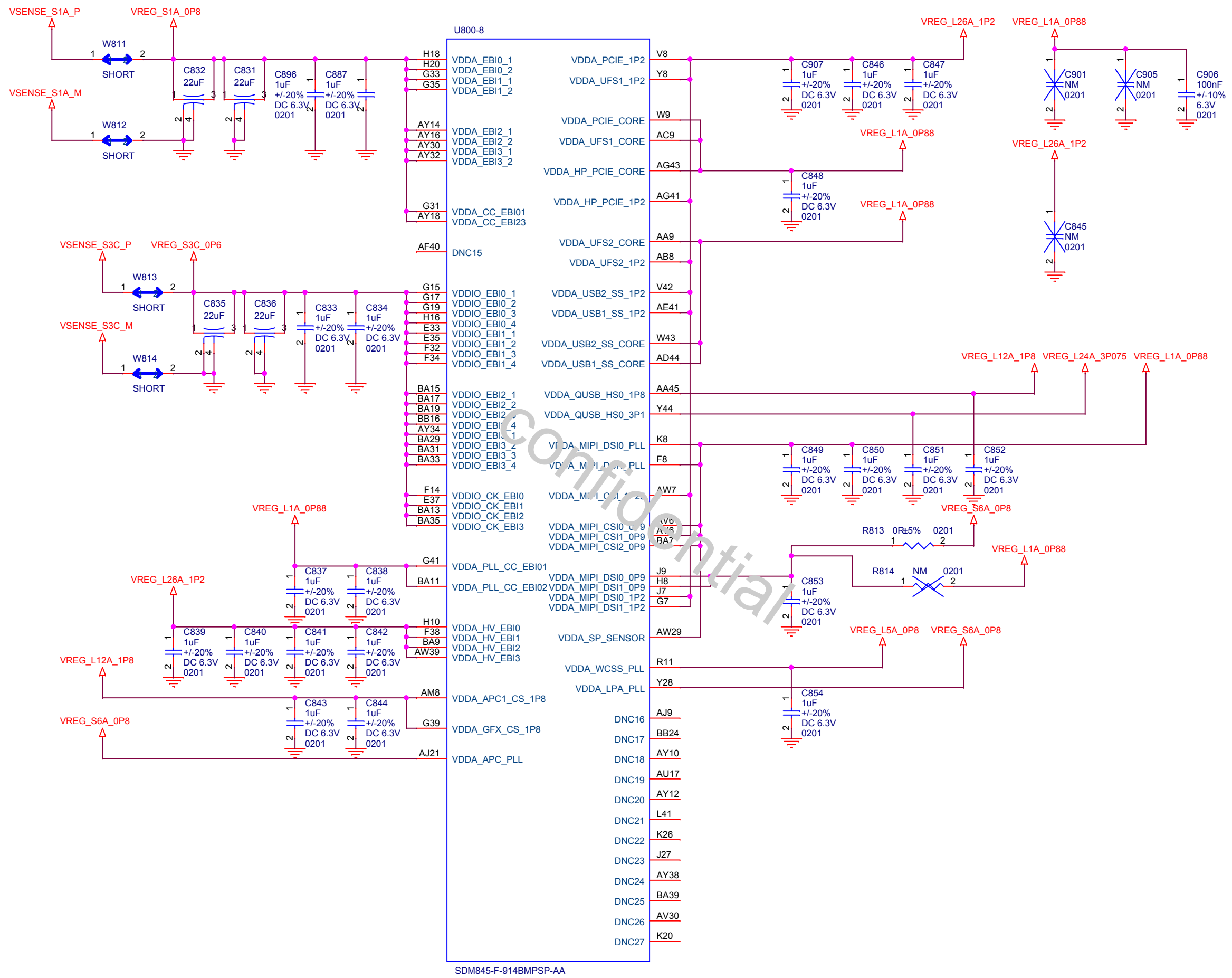

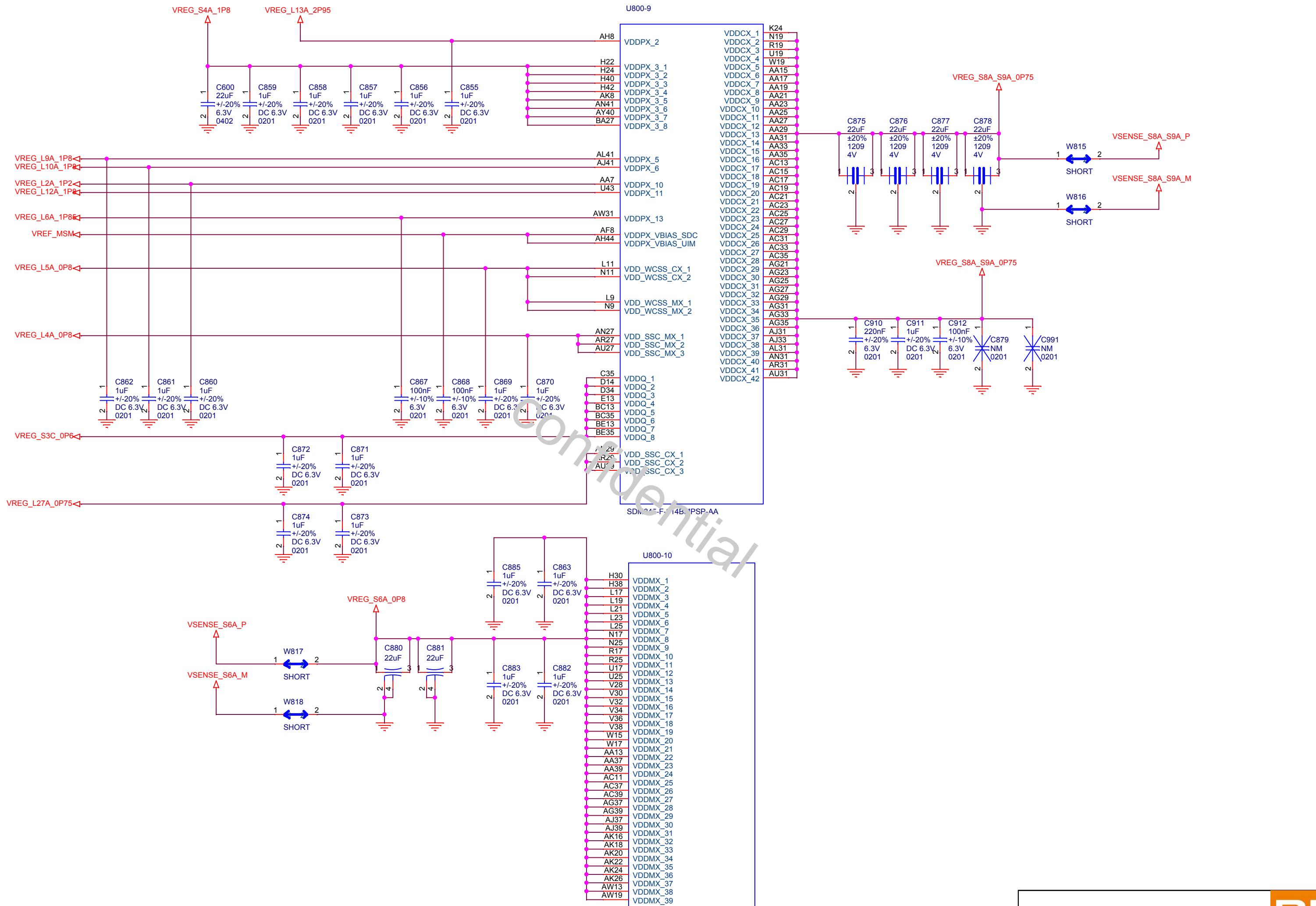

Title		E8	
Size	Document Number	Rev	
A3	SDM845 PWR3	P0	
Date:	Friday, March 23, 2018	Sheet	23 of 44



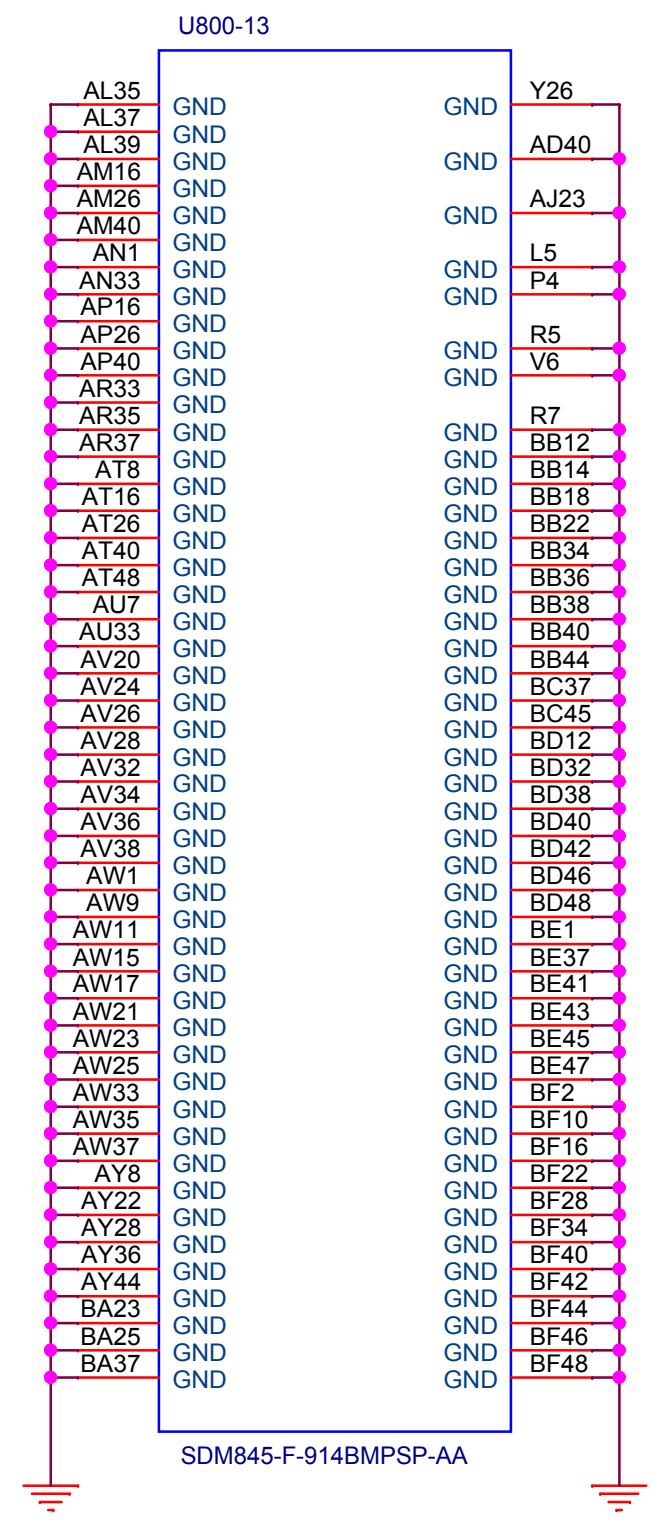
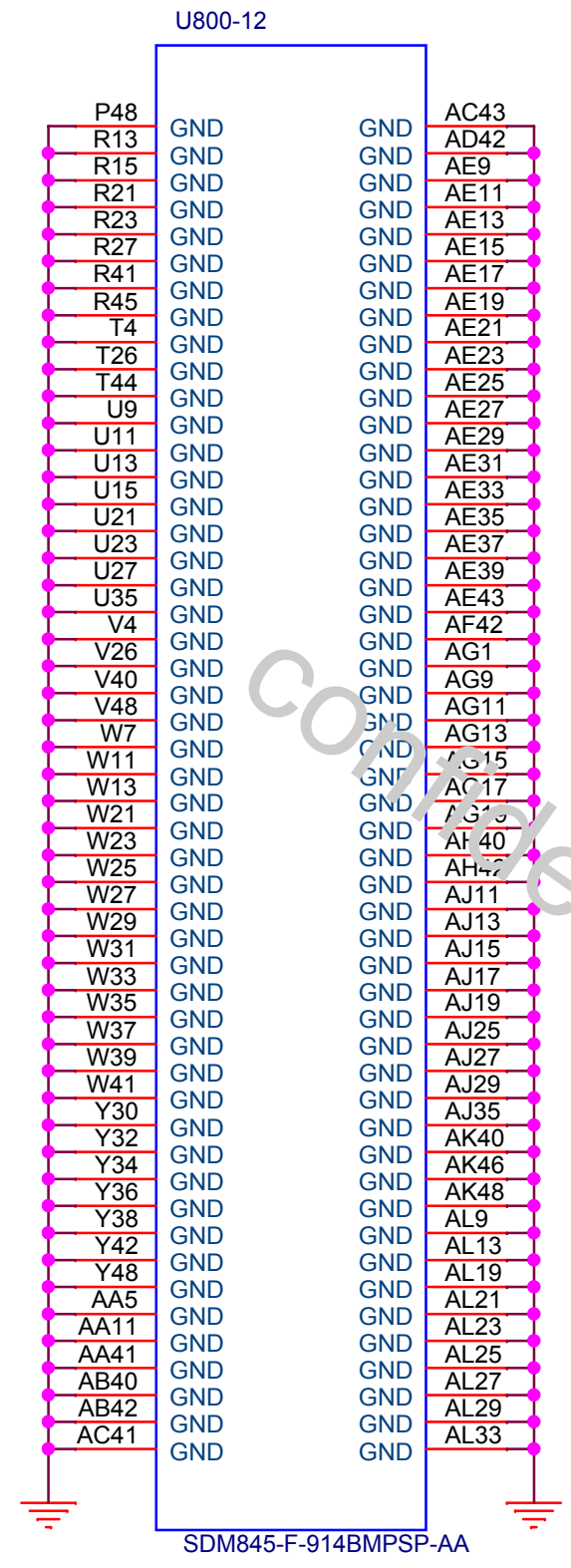
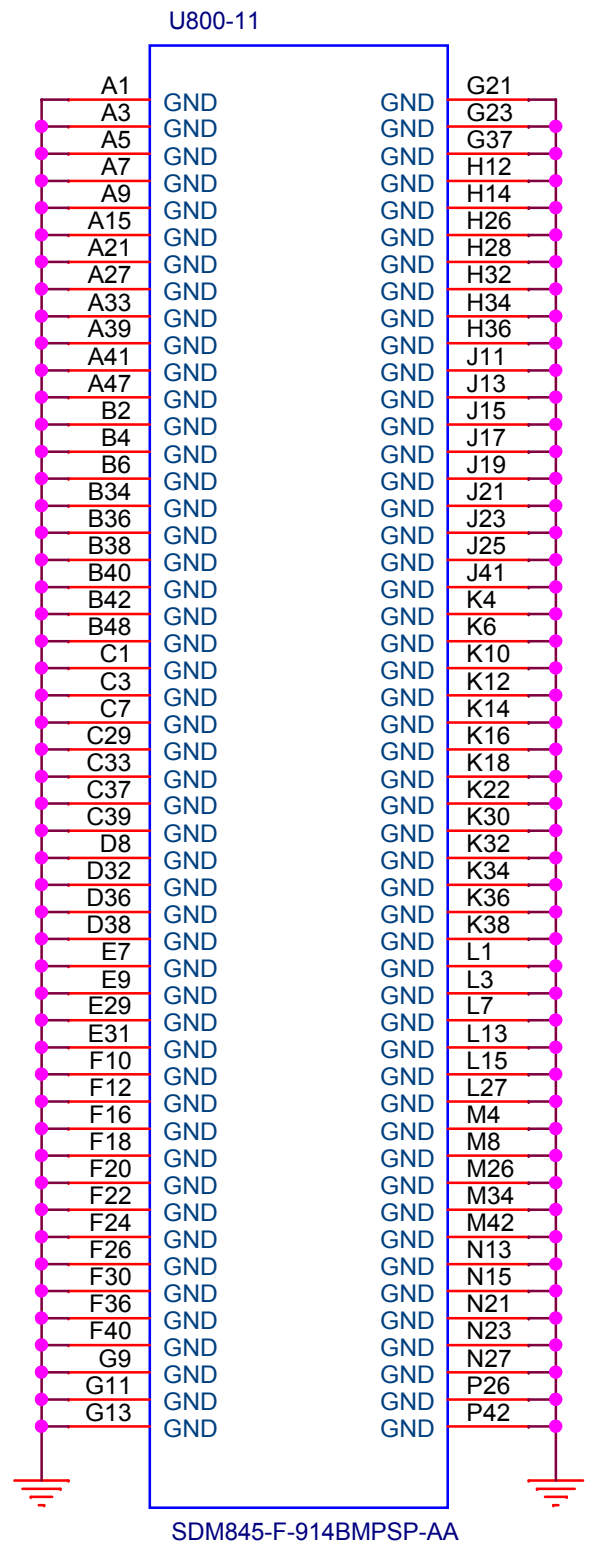

PMI8998

VCONN

BATTERY

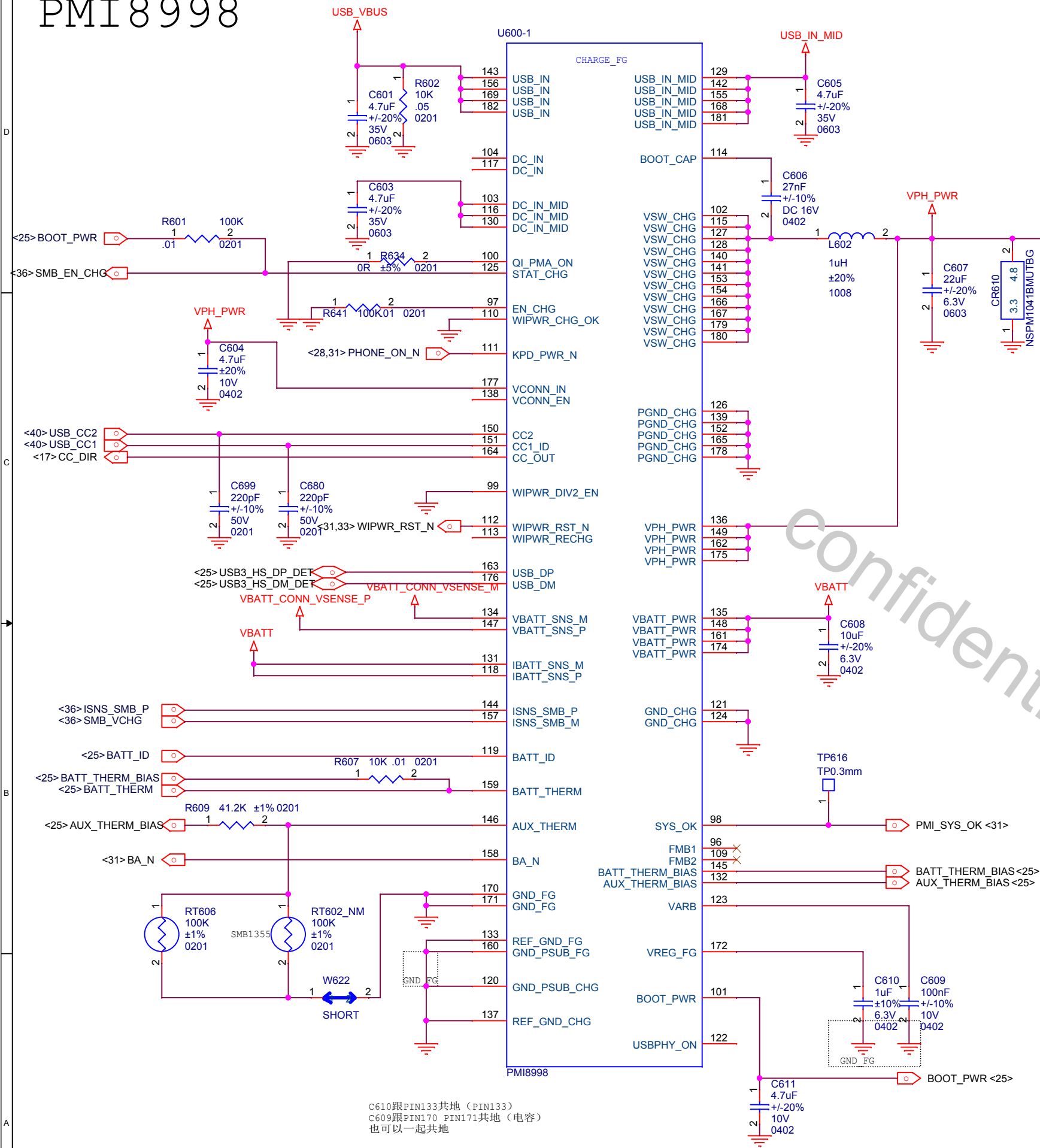

C610跟PIN133共地 (PIN133)
C609跟PIN170 PIN171共地 (电容)
也可以一起共地

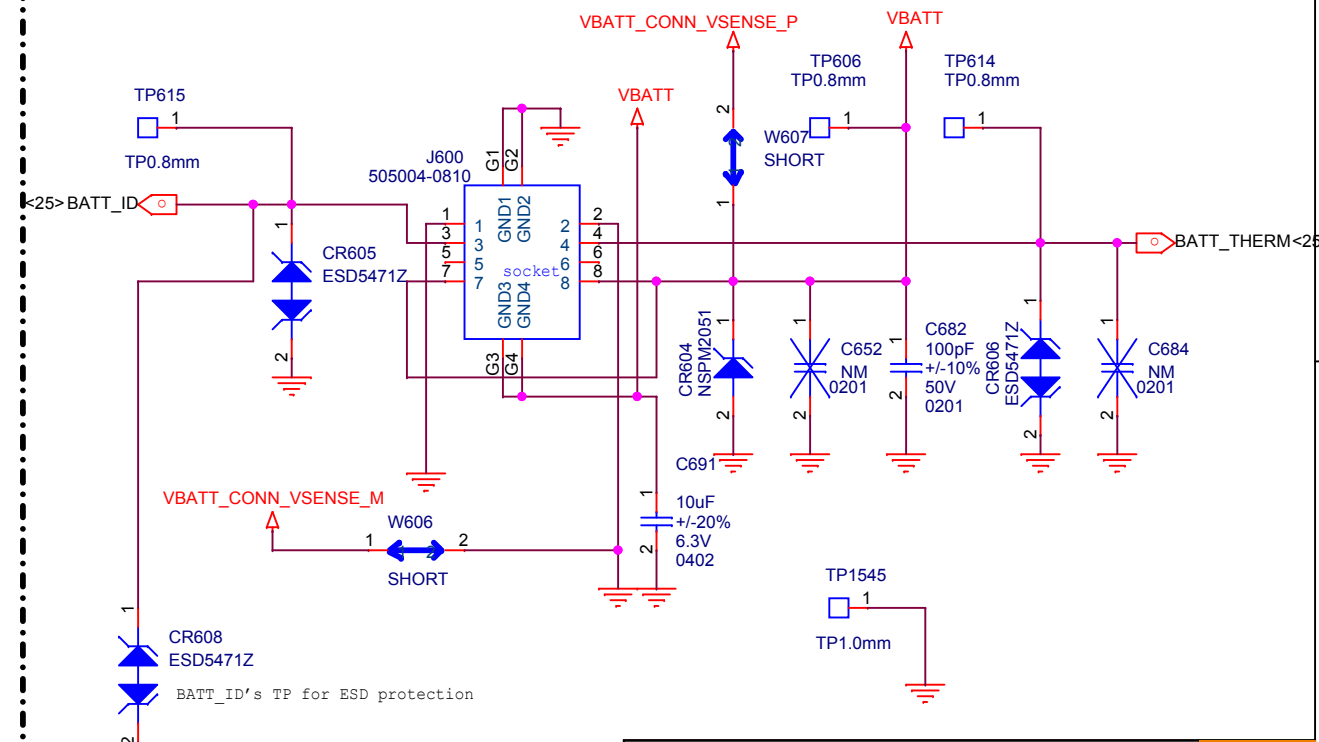
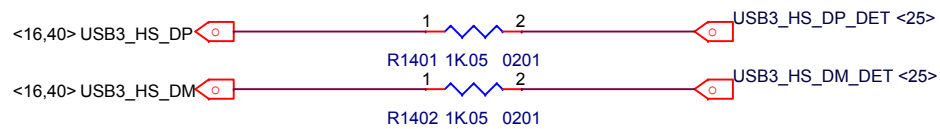

Title		E8	
Size	A3	Document Number	Rev P0
Date:		Friday, March 23, 2018	Sheet 25 of 44

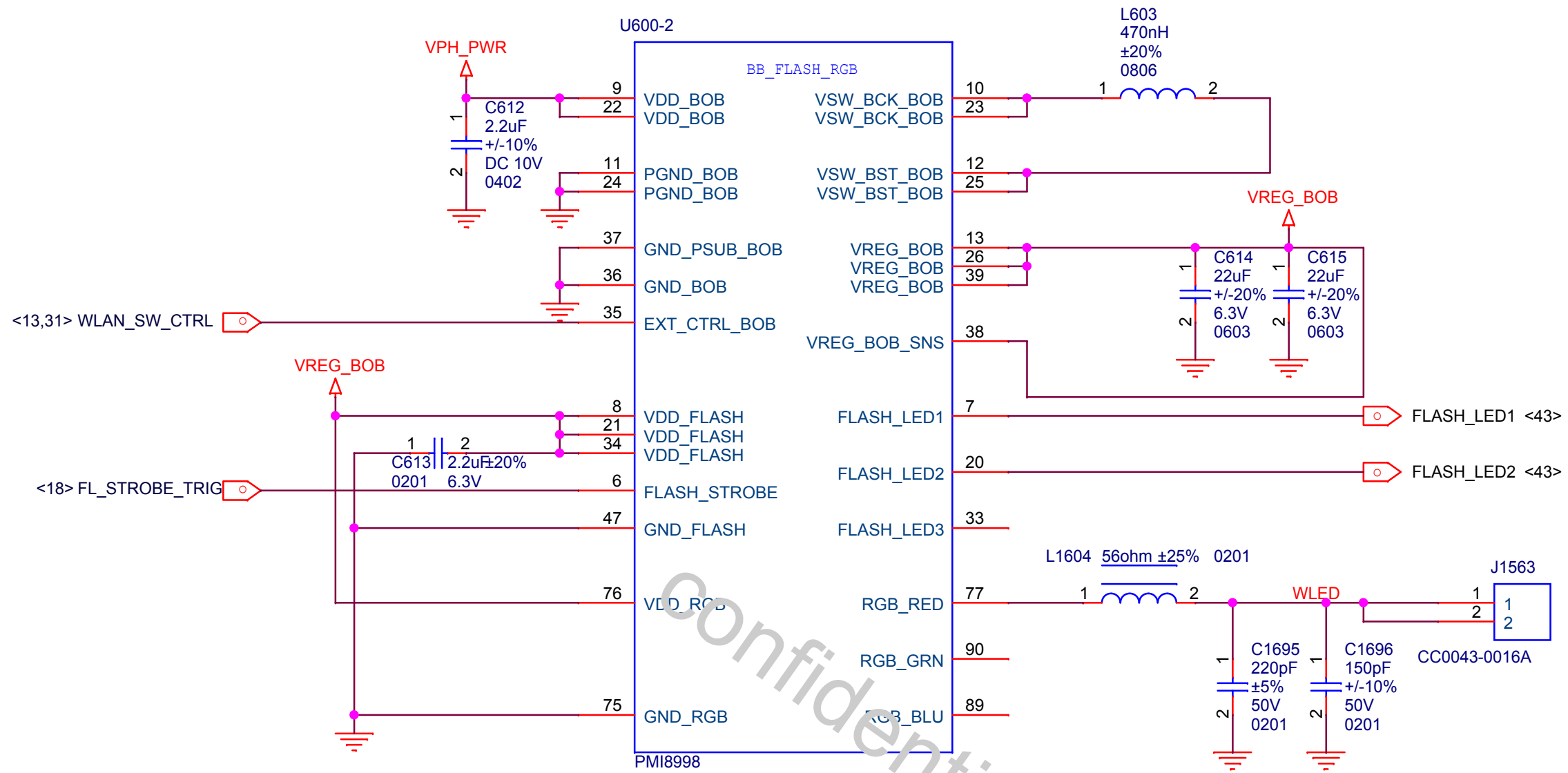

FLASH Board

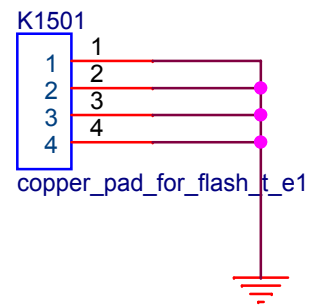

Title		E8	
Size	Document Number		
A4	PMI8998 FLASH RGB	Rev	P0
Date:	Friday, March 23, 2018	Sheet	26 of 44

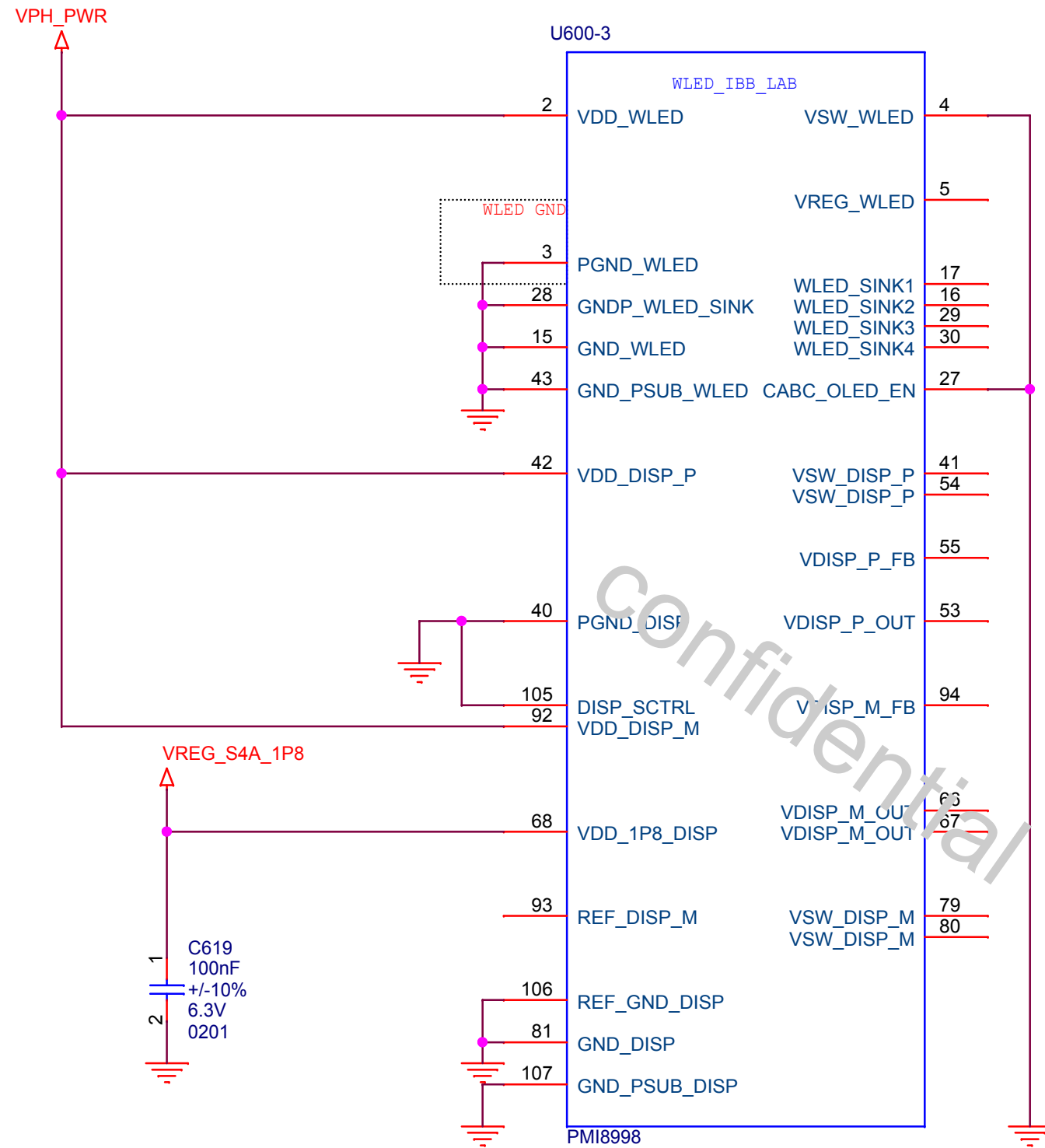

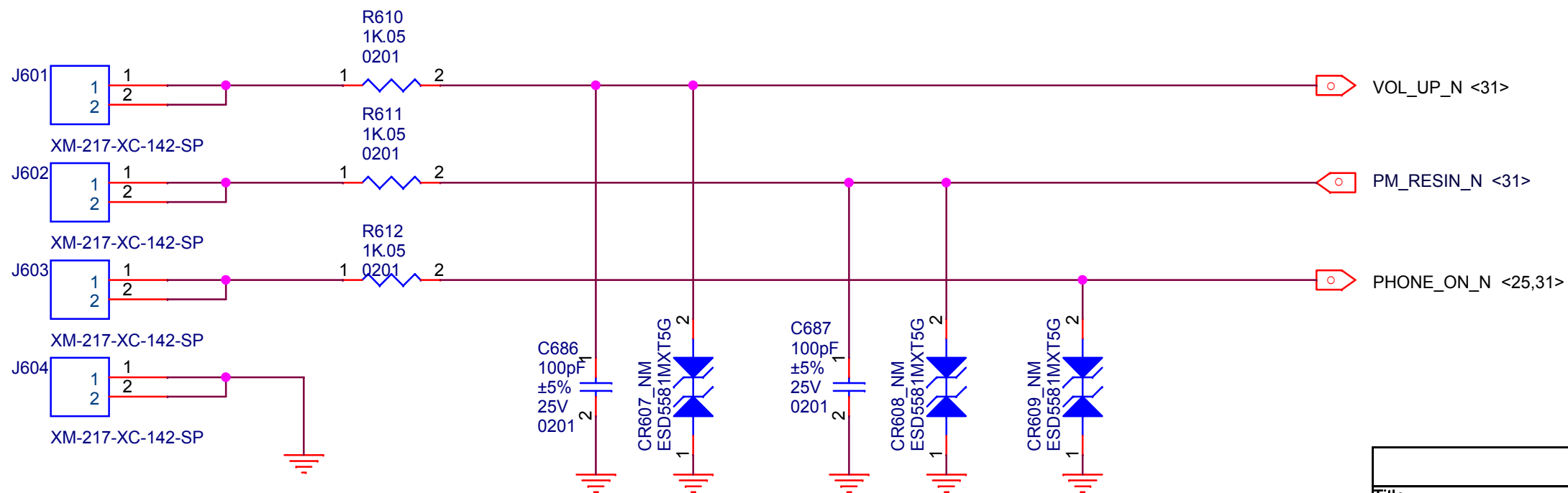
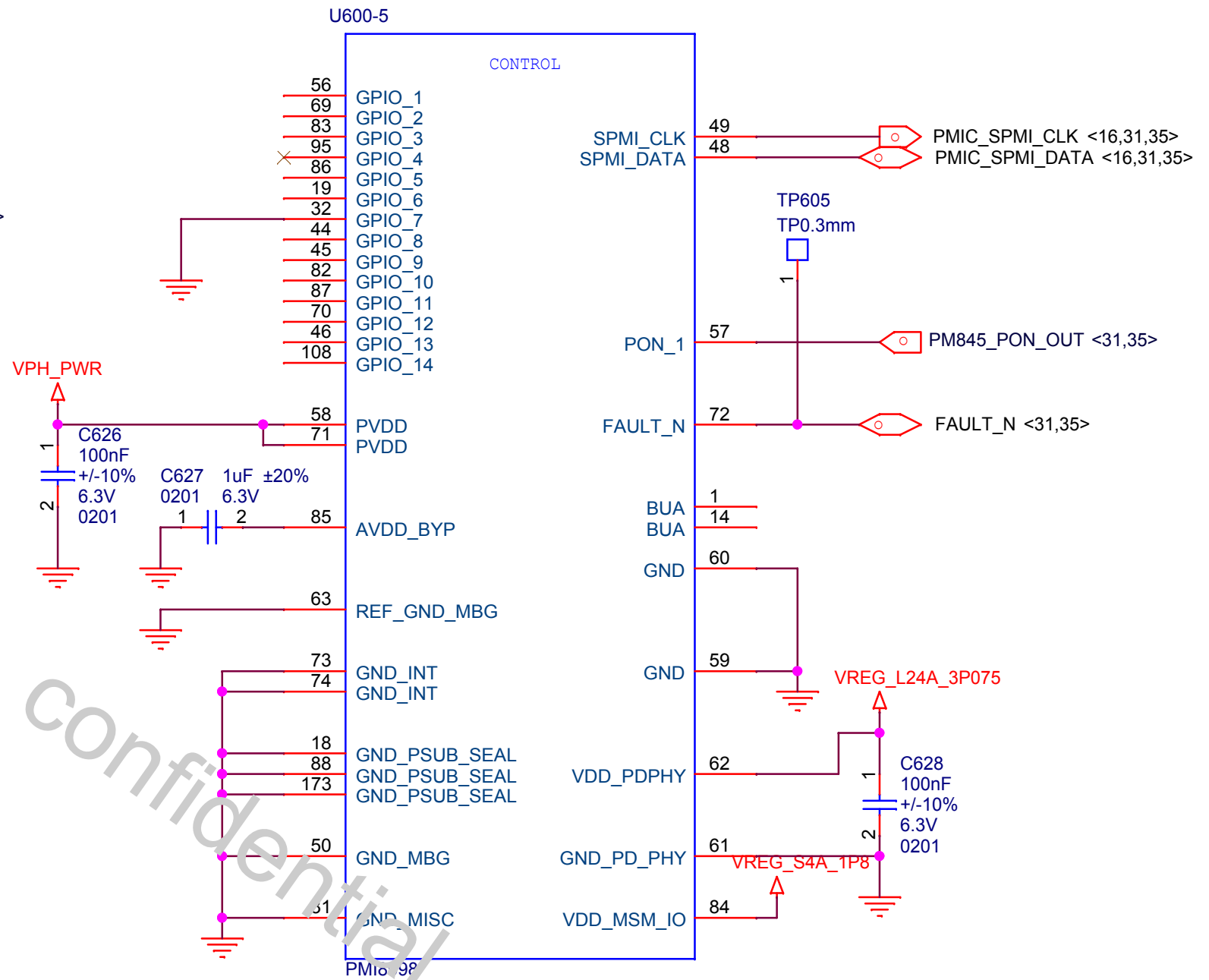
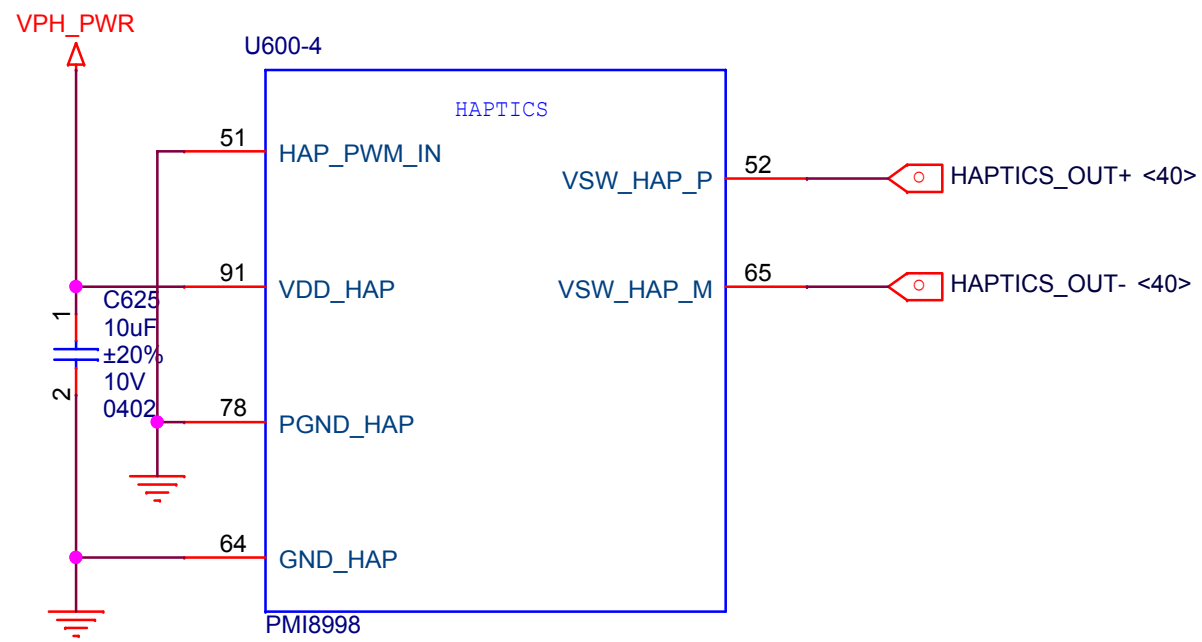

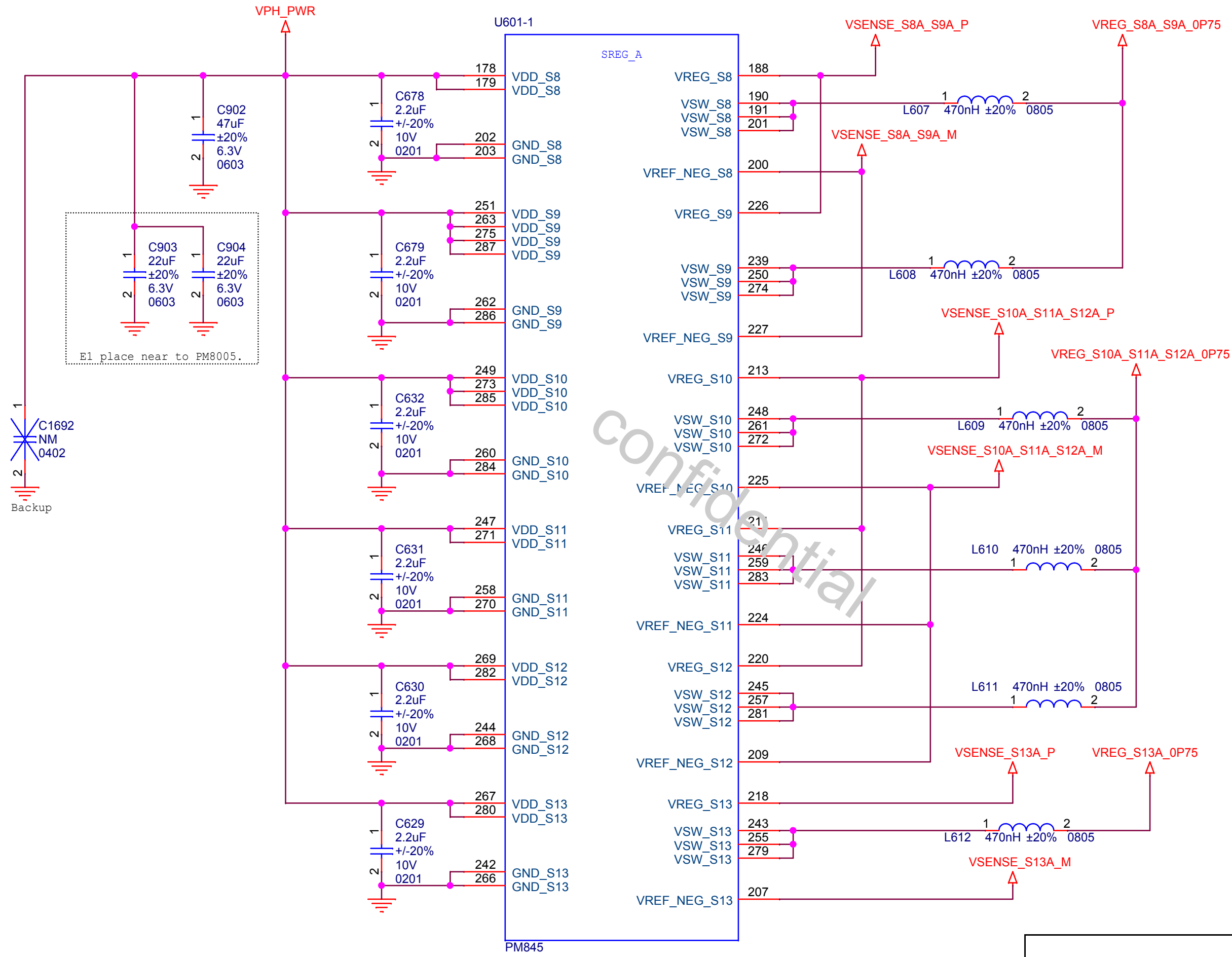

Title		E8			
Size	A4	Document Number	PMI8998 HAPTICS&SIDEKEY		Rev
Date:	Friday, March 23, 2018		Sheet	28	of 44

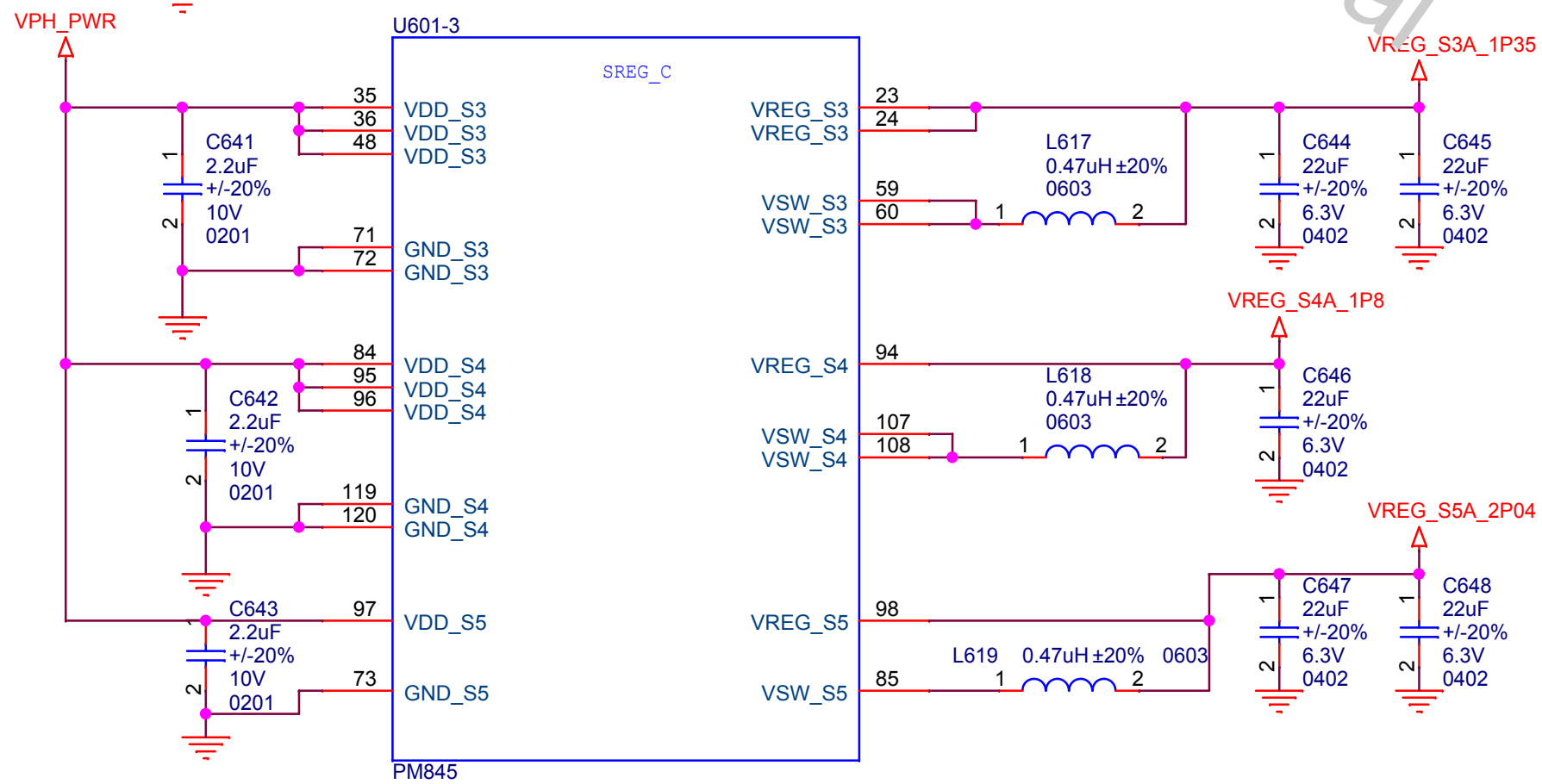
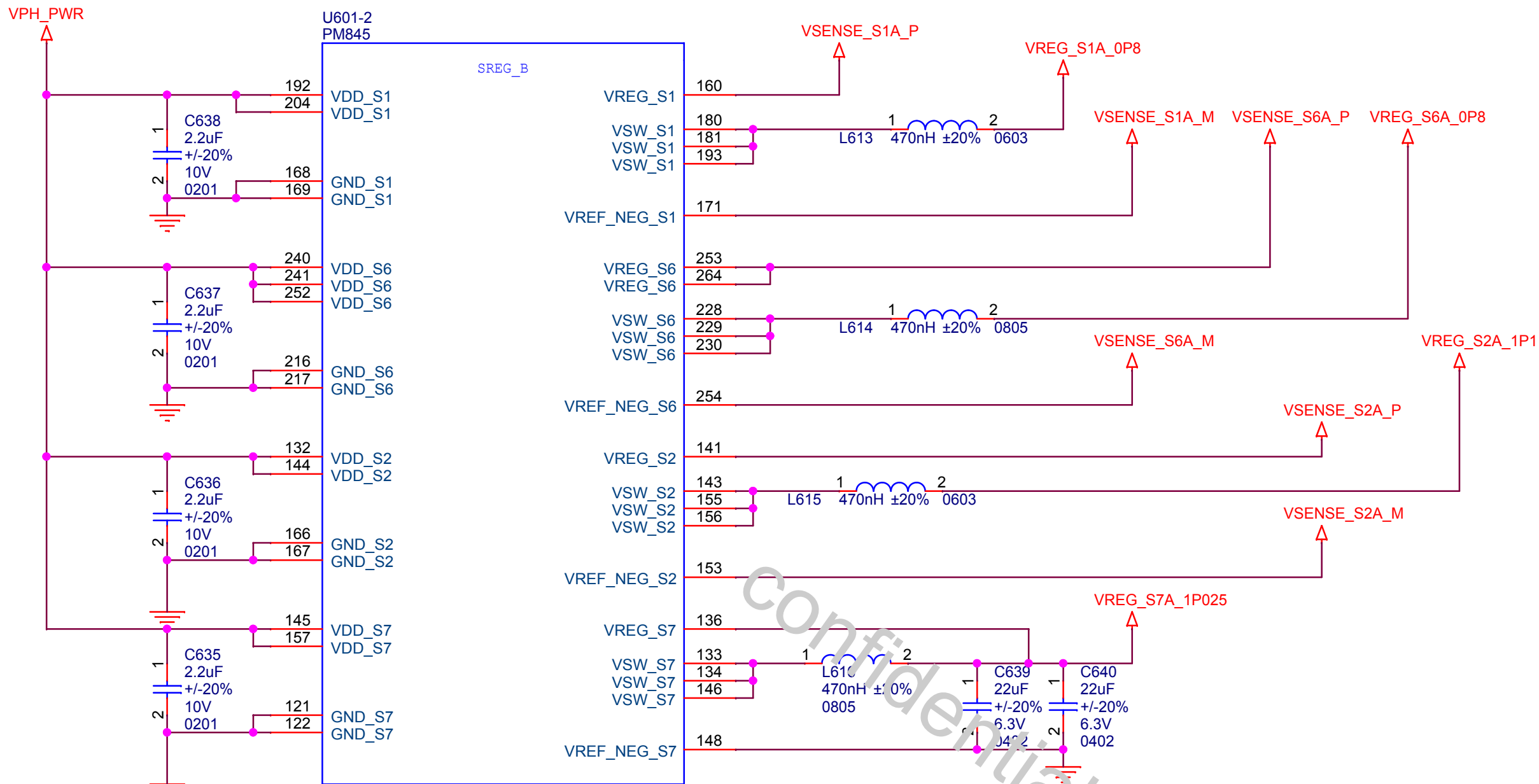

Confidential

Title		E8			
Size	A4	Document Number	PM845 SREG A		Rev
Date:	Friday, March 23, 2018	Sheet	29	of	44
				Rev	P0



Title		E8			
Size	A4	Document Number	PM845 SREG B&C		Rev
Date:	Friday, March 23, 2018		Sheet	30	of 44

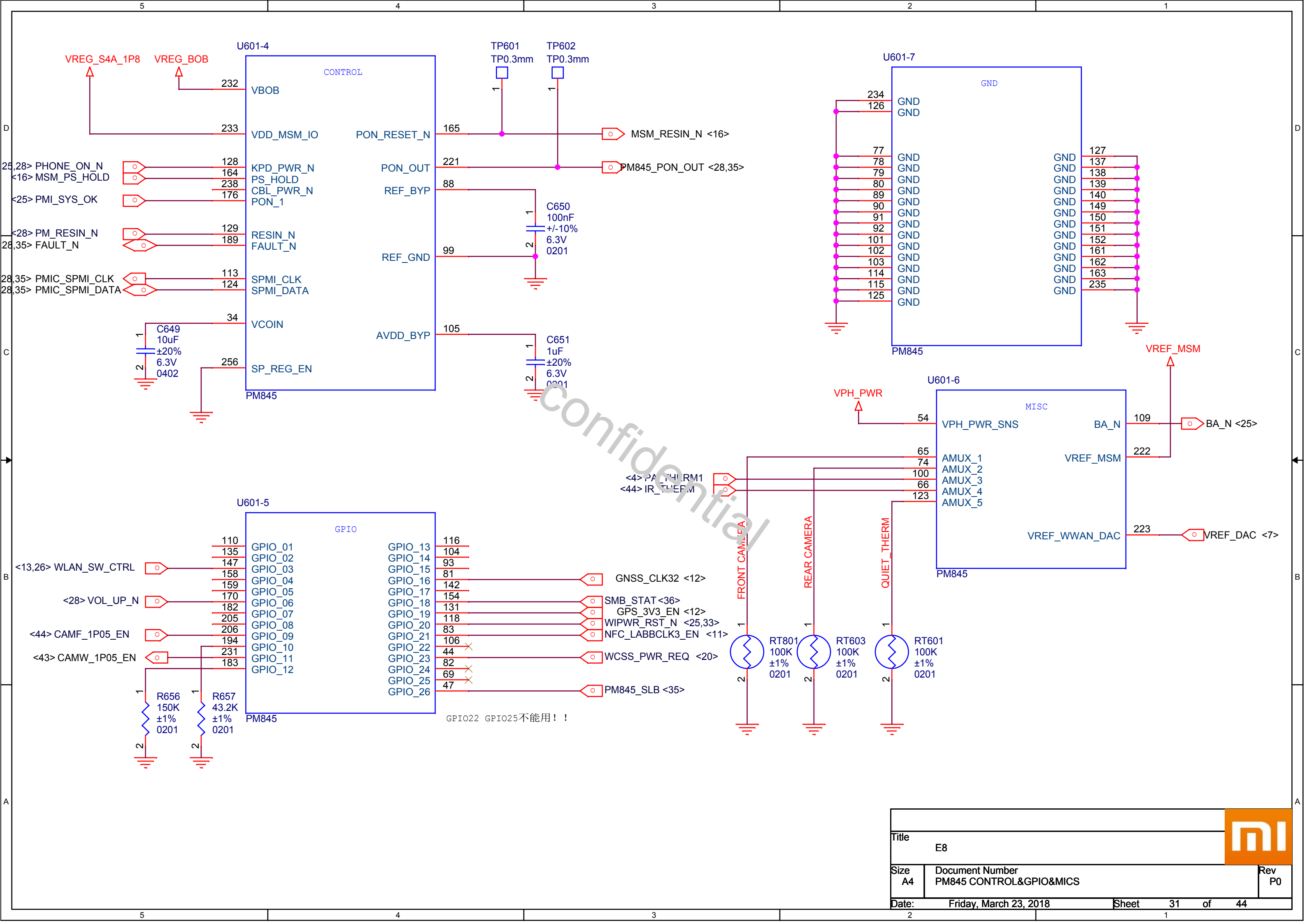

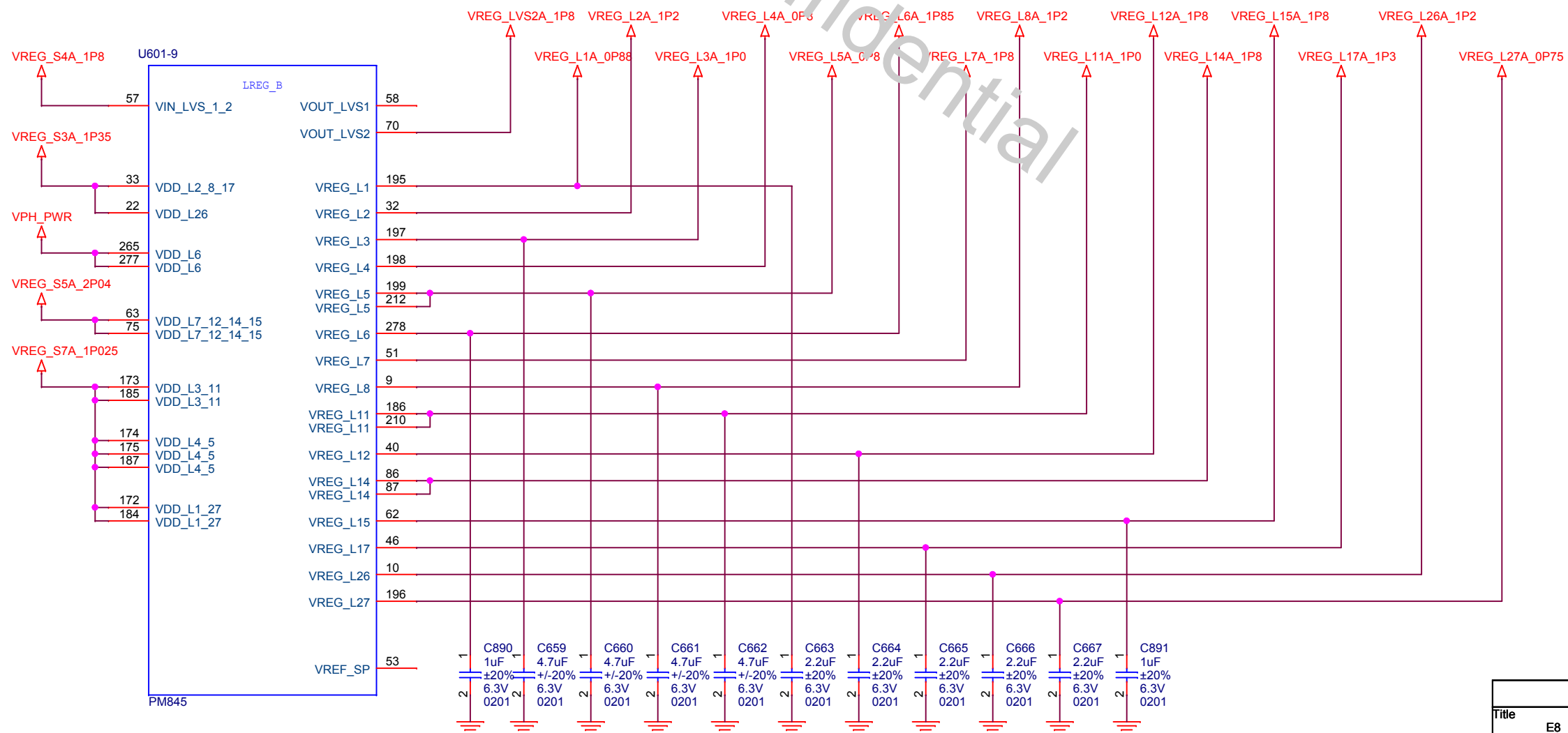
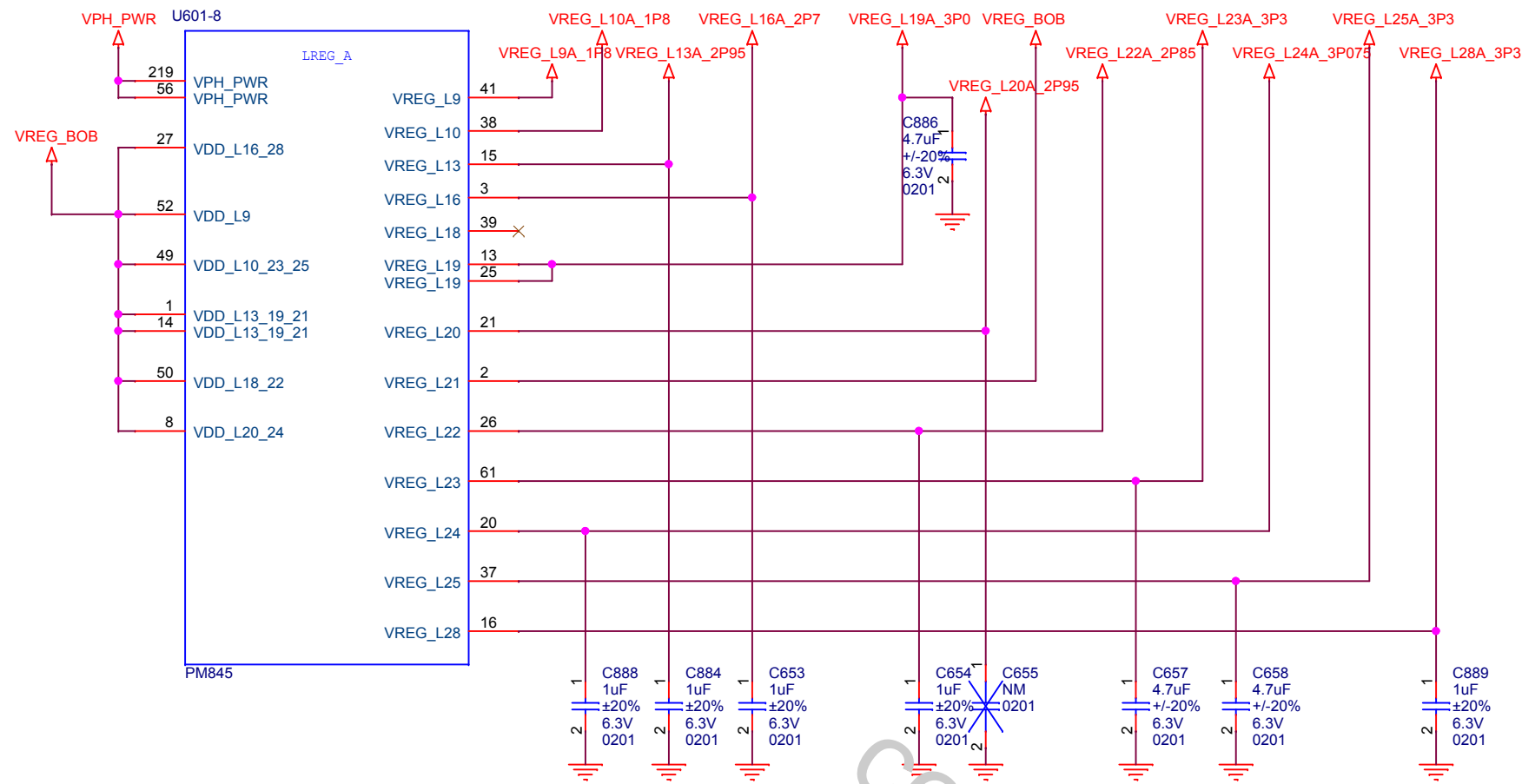

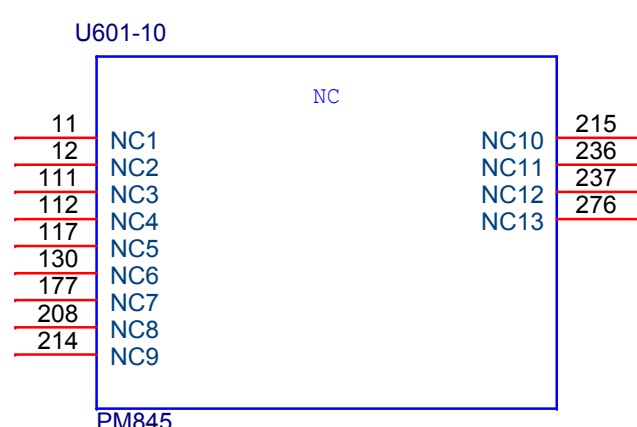
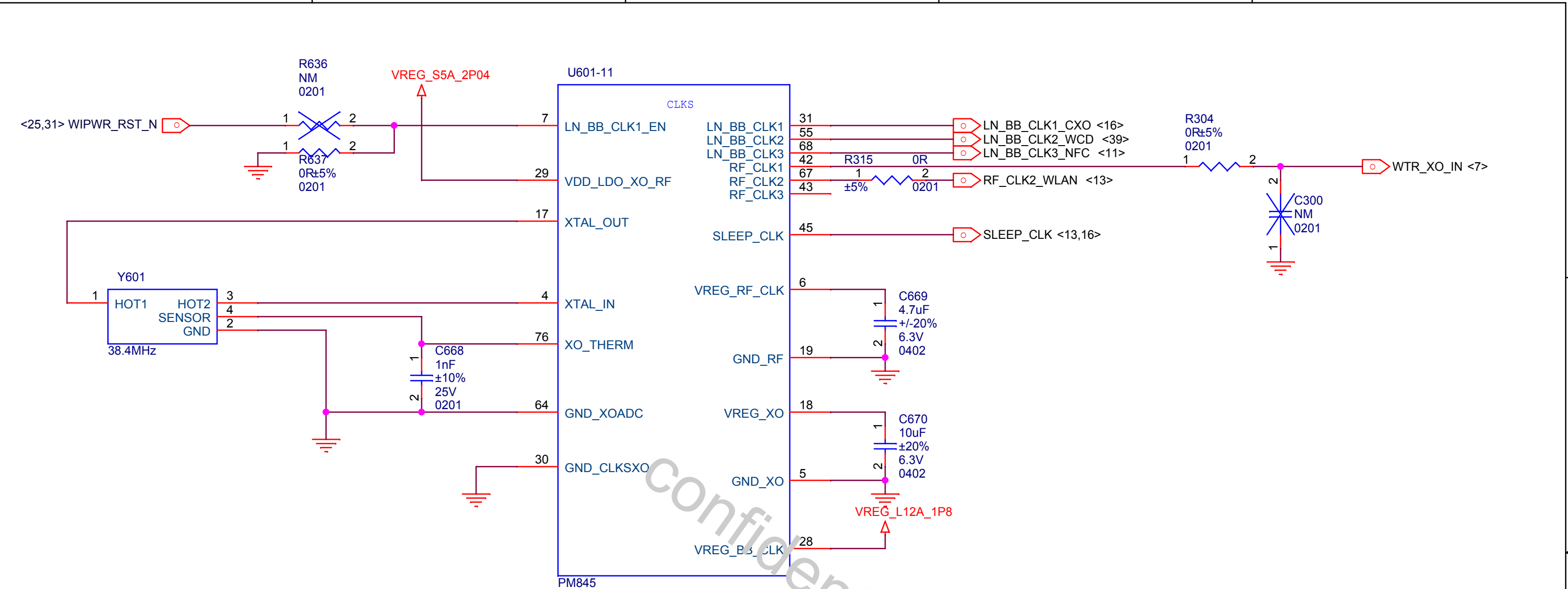

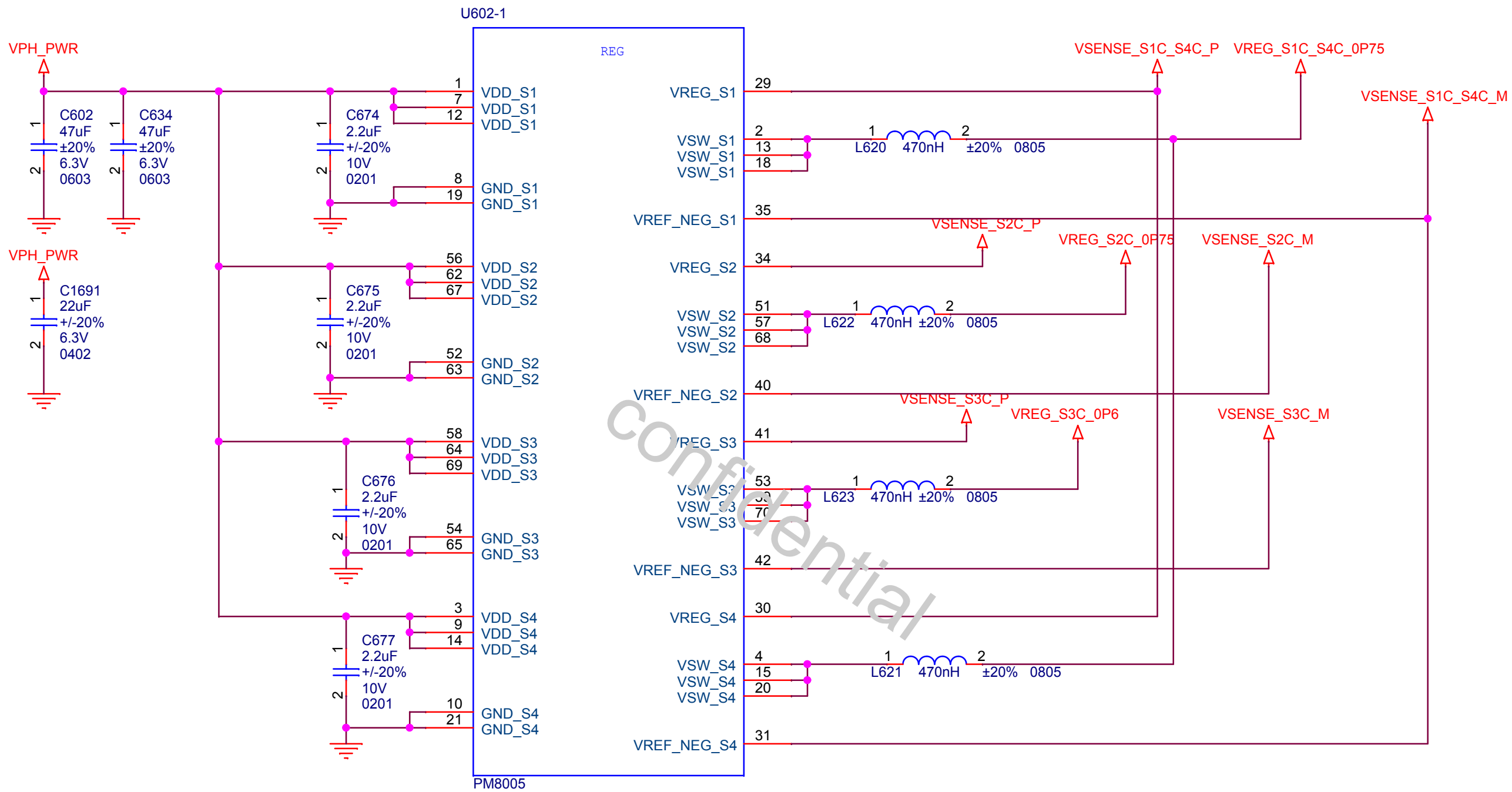

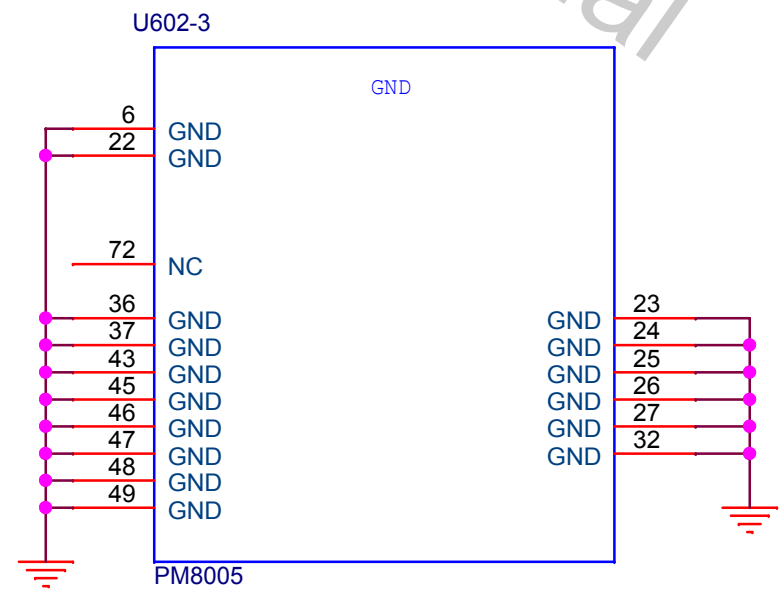
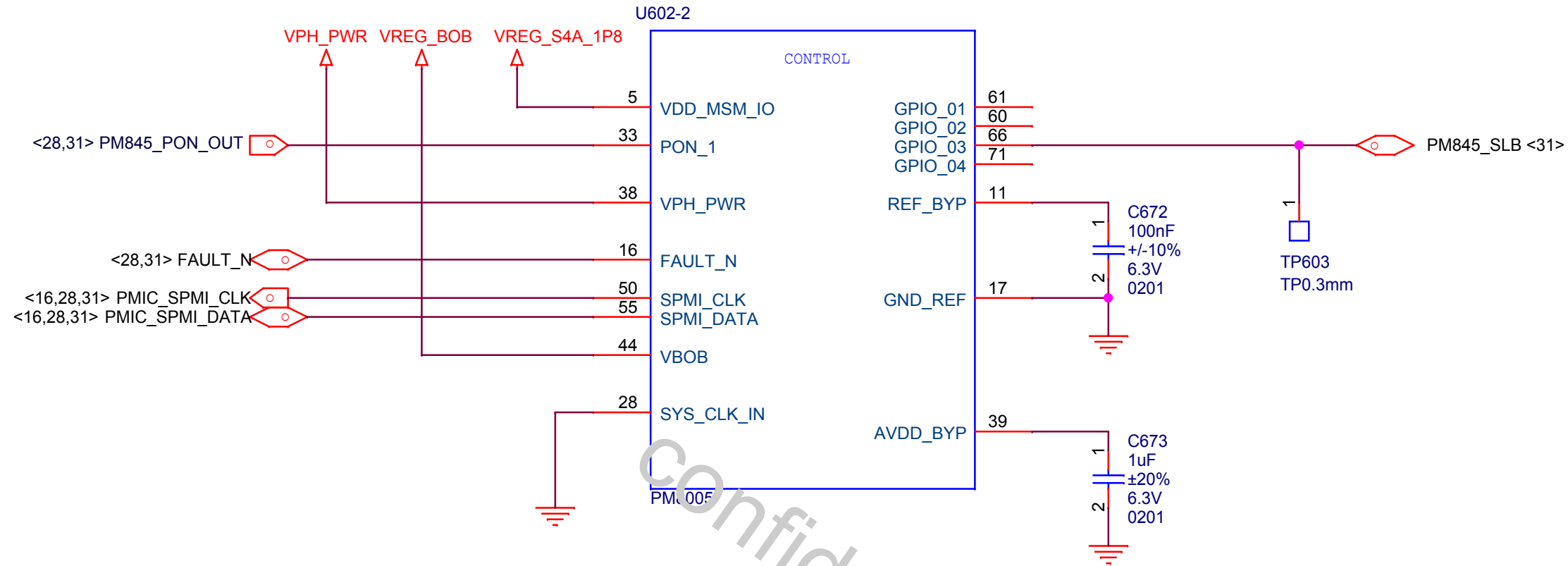

Confidential

Title		E8			
Size	A4	Document Number	PM8005 REG		Rev
Date:	Friday, March 23, 2018		Sheet	34	of 44



Confidential

Title		E8			
Size	A4	Document Number	PM8005 CONTROL&GND		Rev
Date:	Friday, March 23, 2018		Sheet	35	of 44

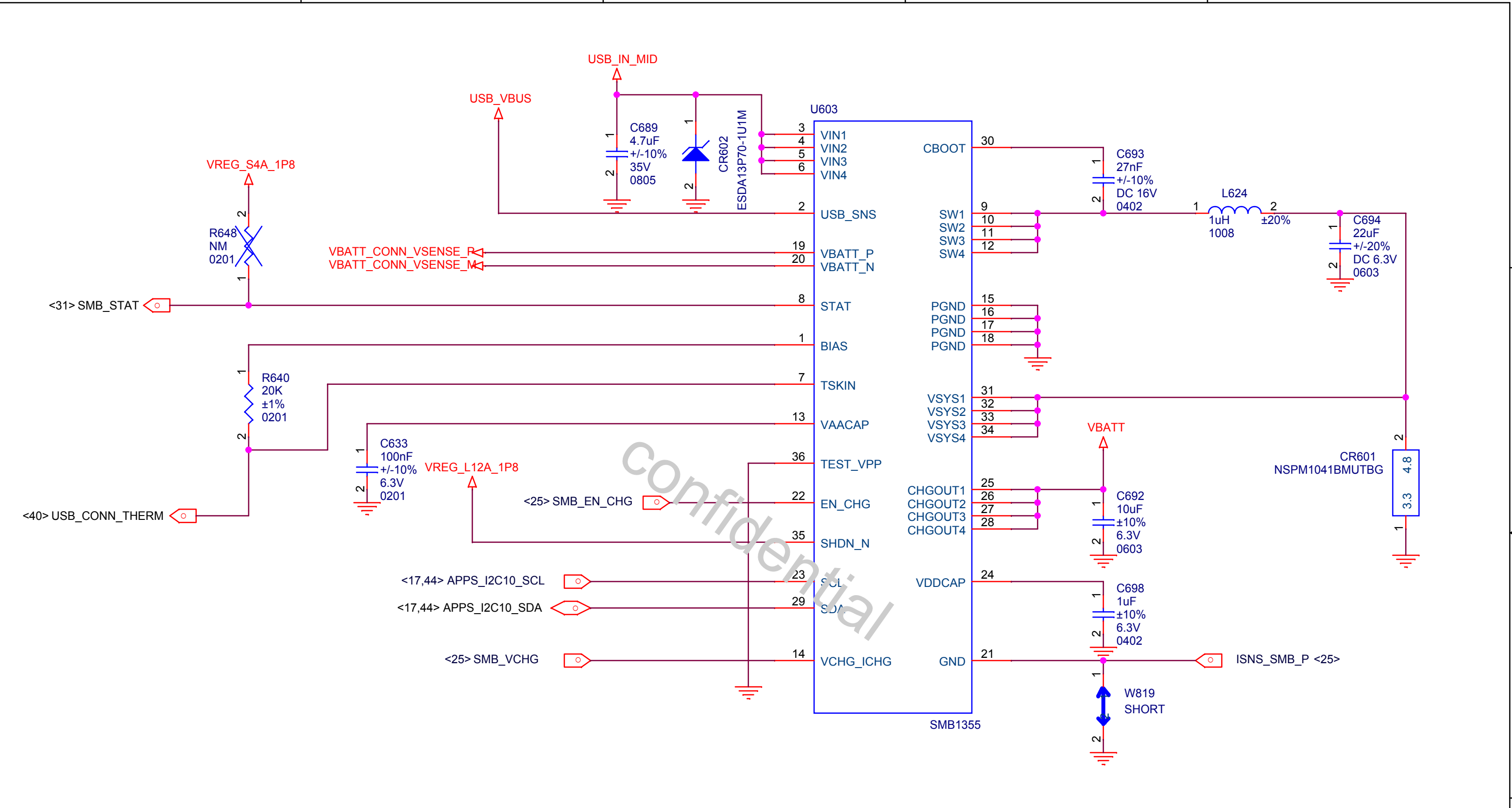

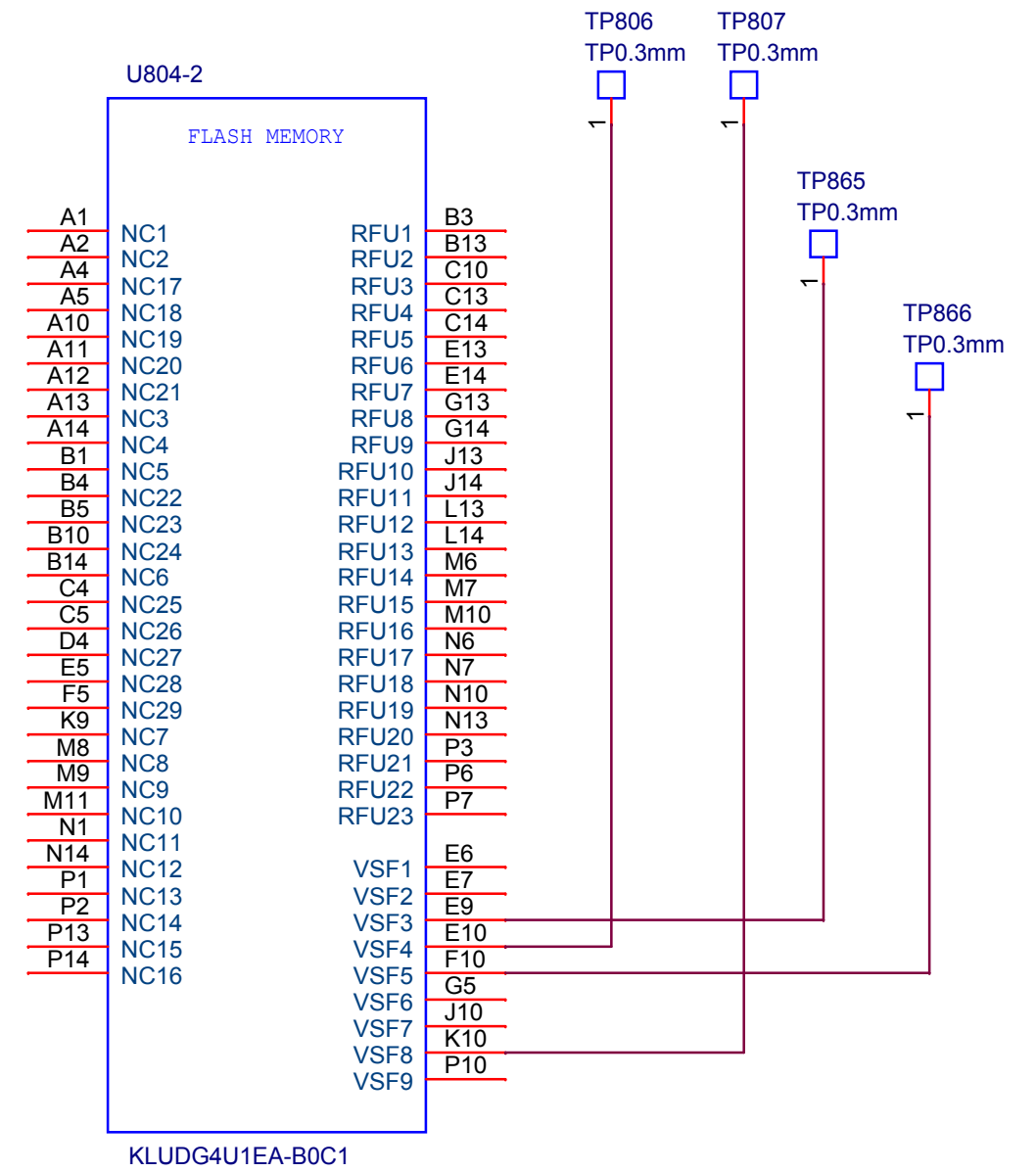
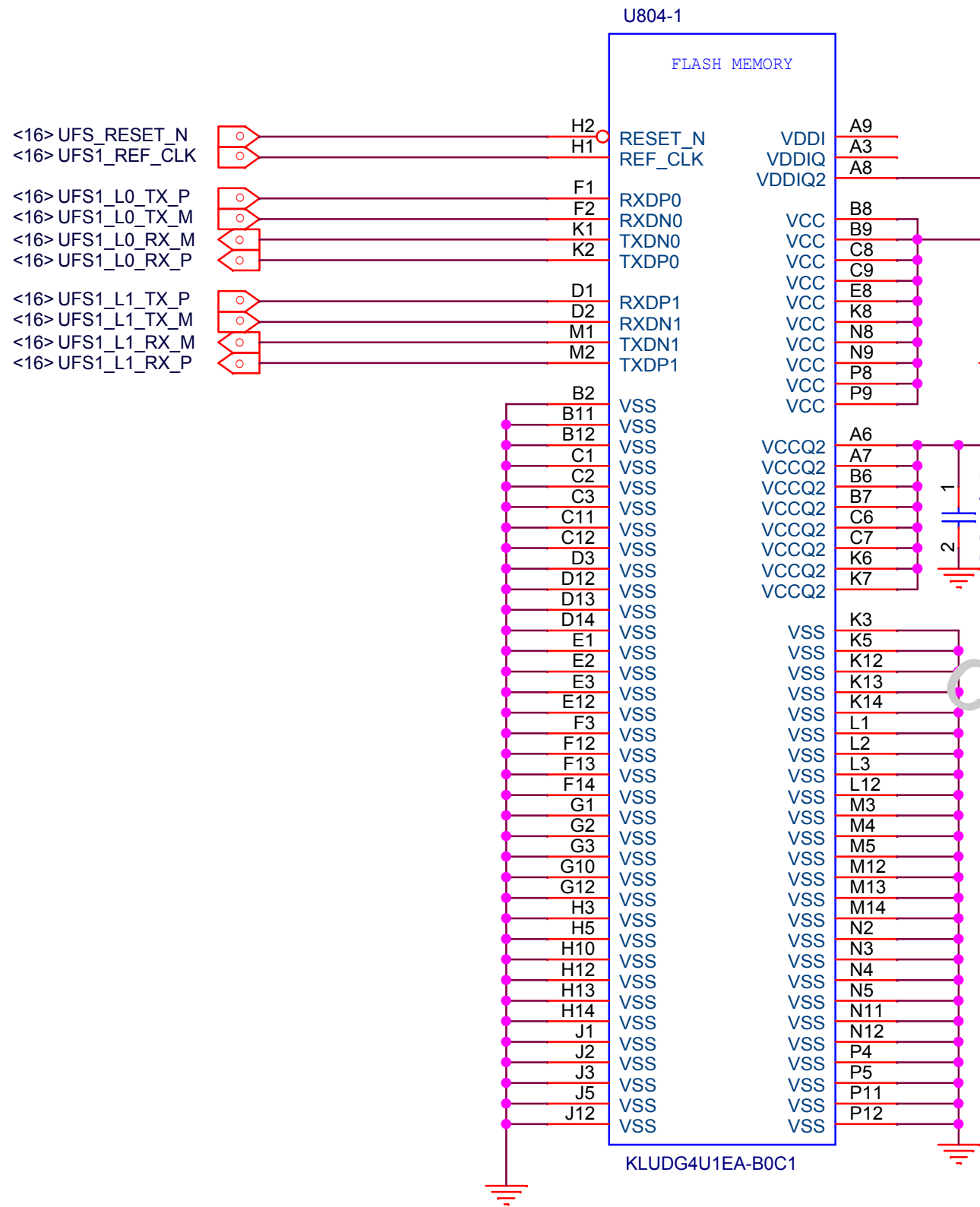

Speaker PA

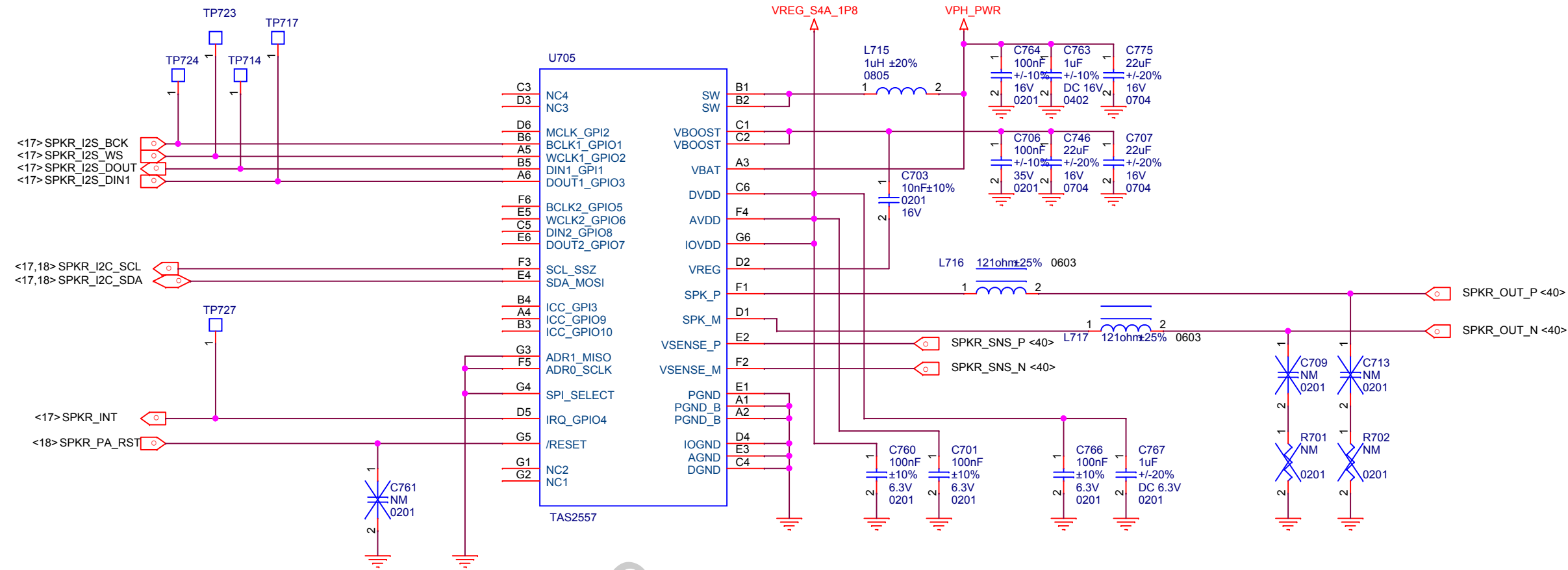

AUX Mic

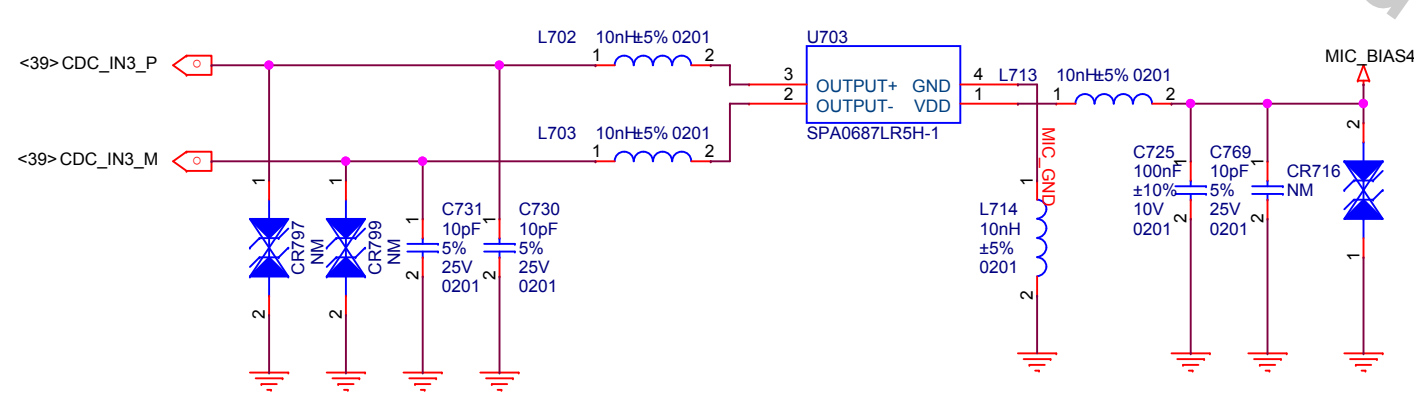

Receiver

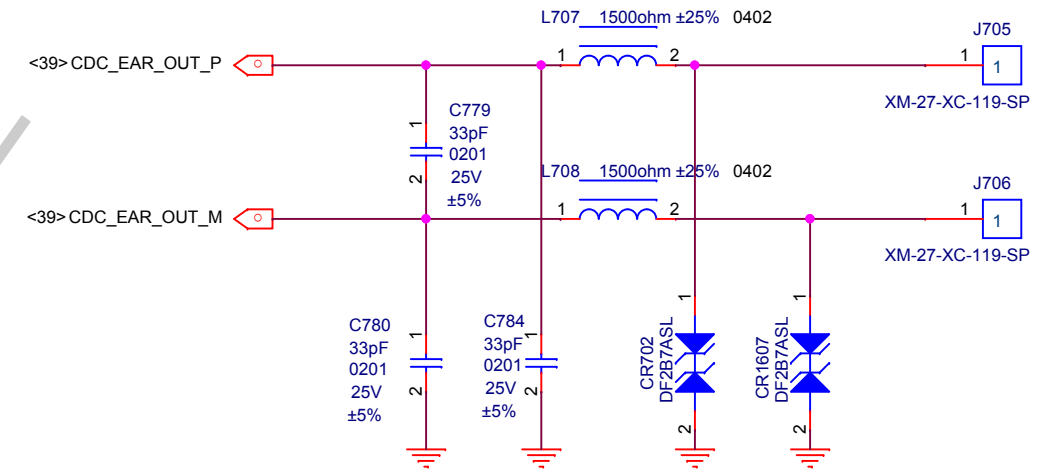

HEADSET

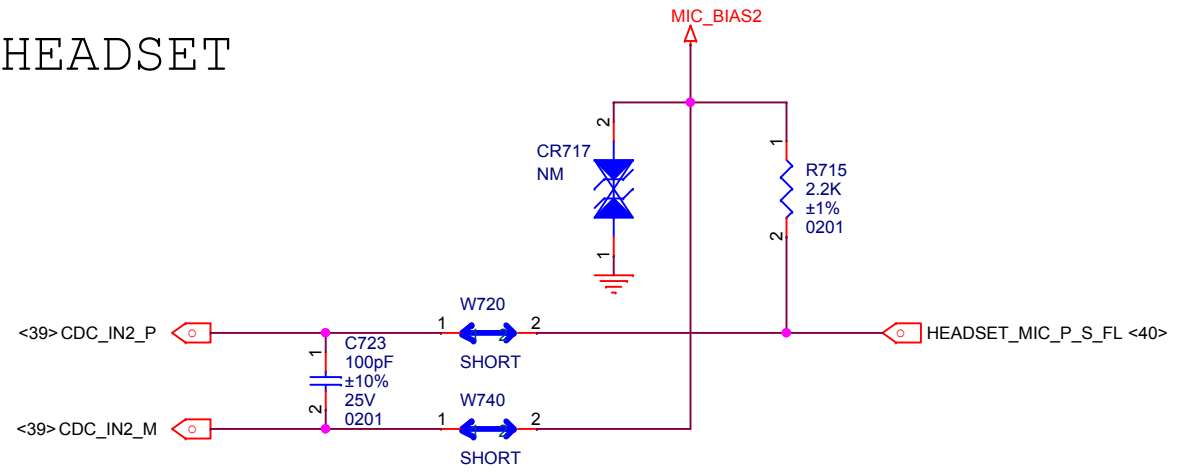

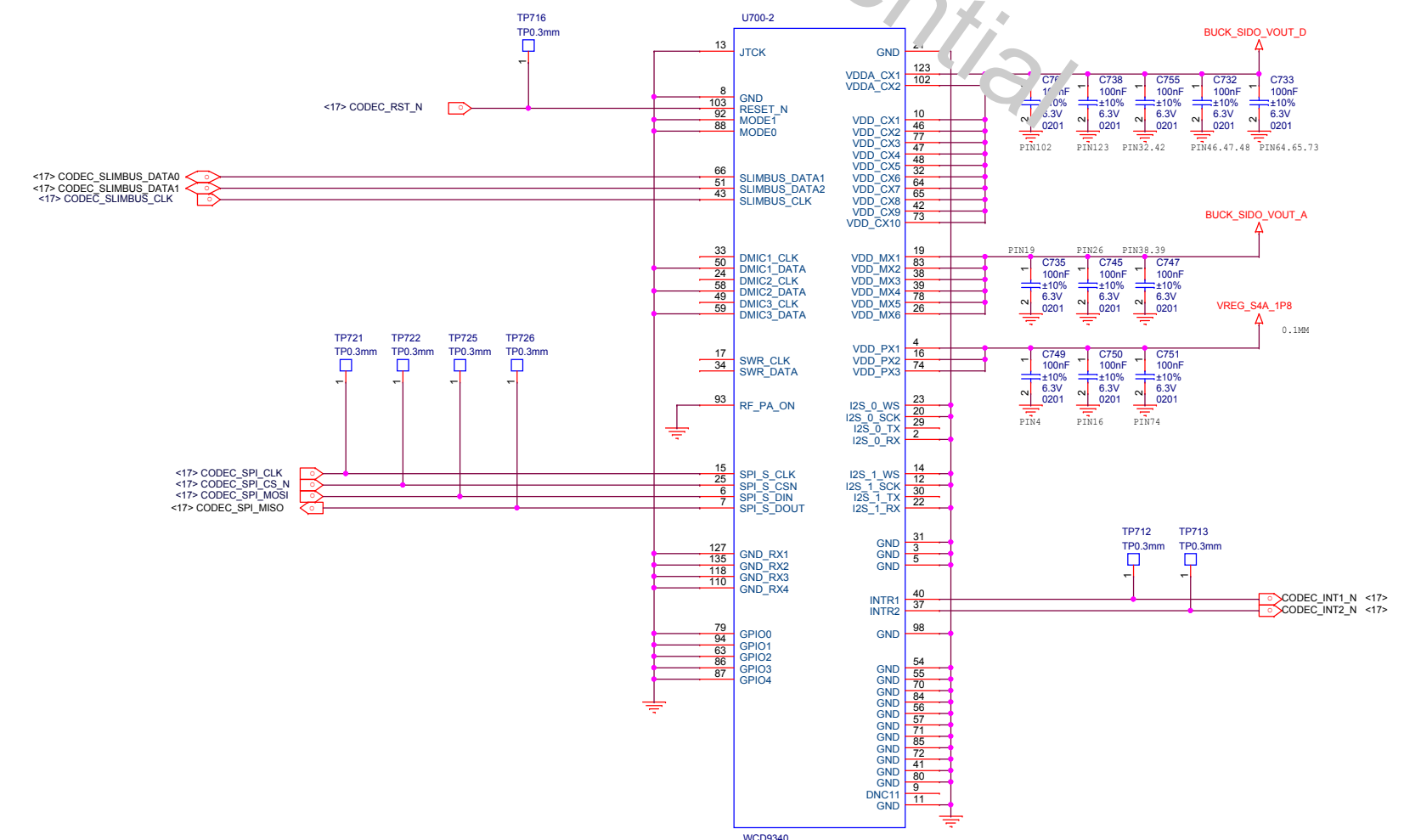
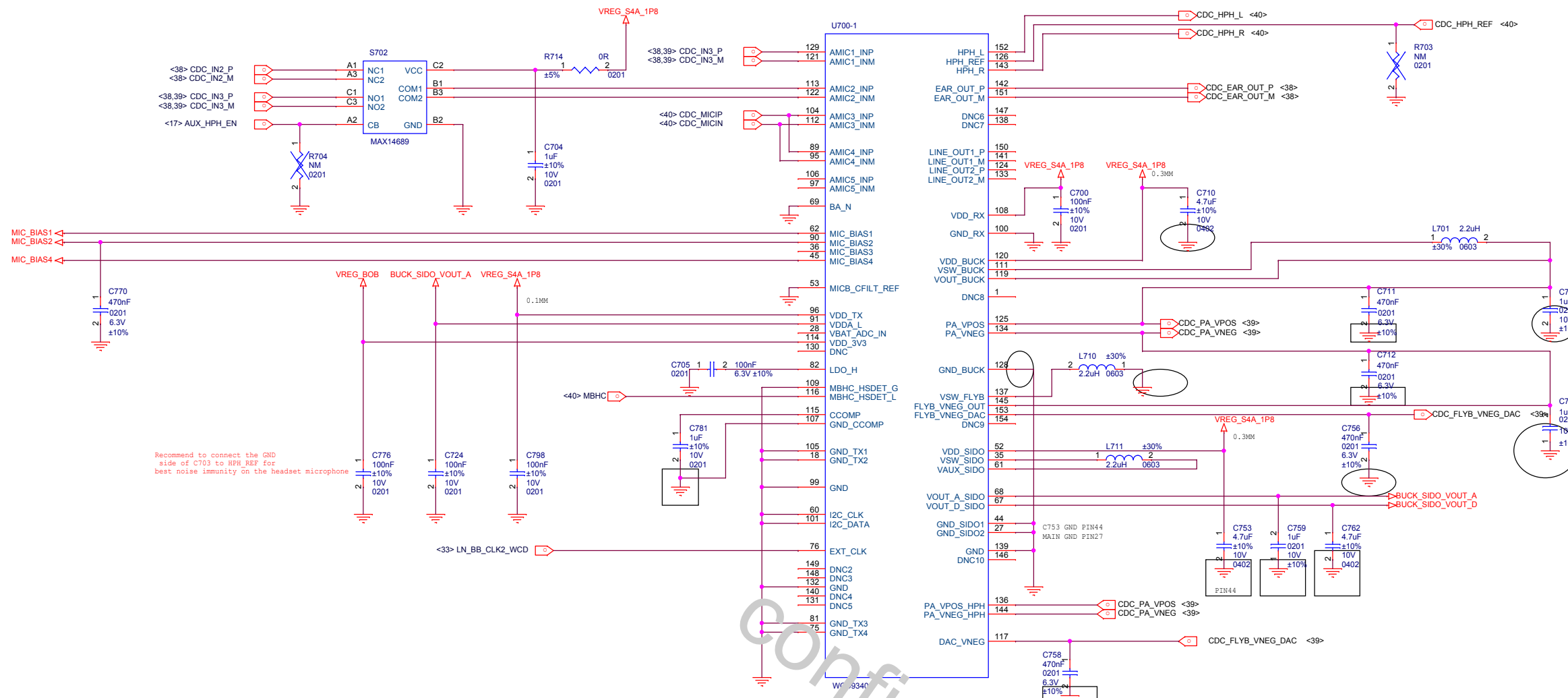

LCD PWR

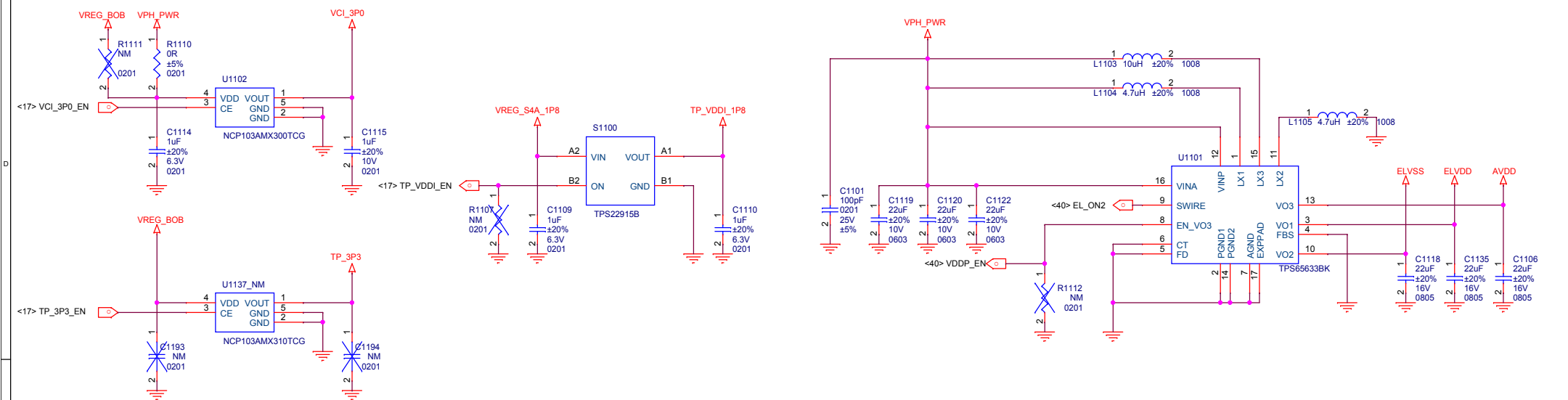

LCD Filter

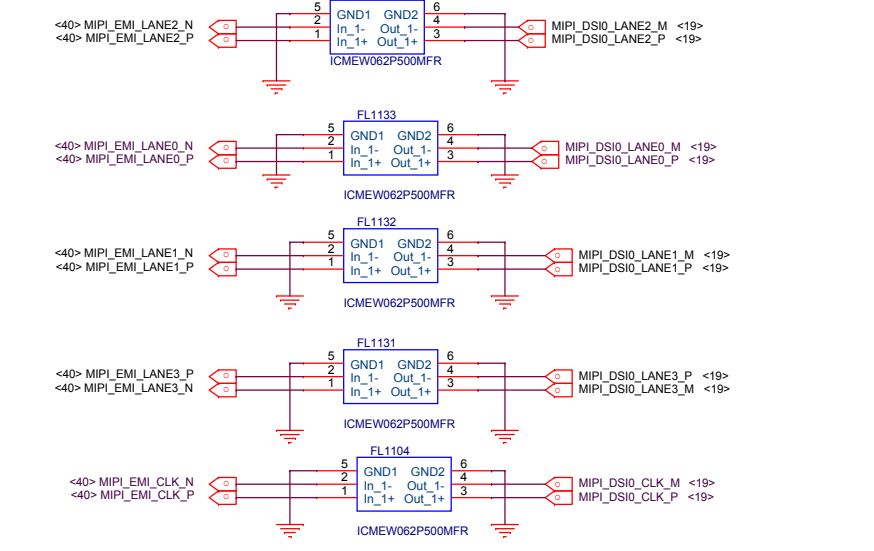

LCD Connector PIN MAP!!!

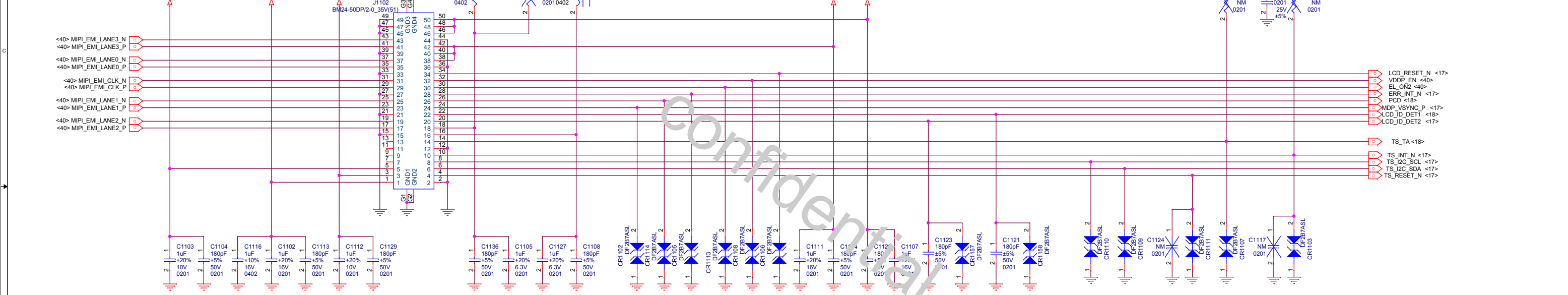

BTB Connector

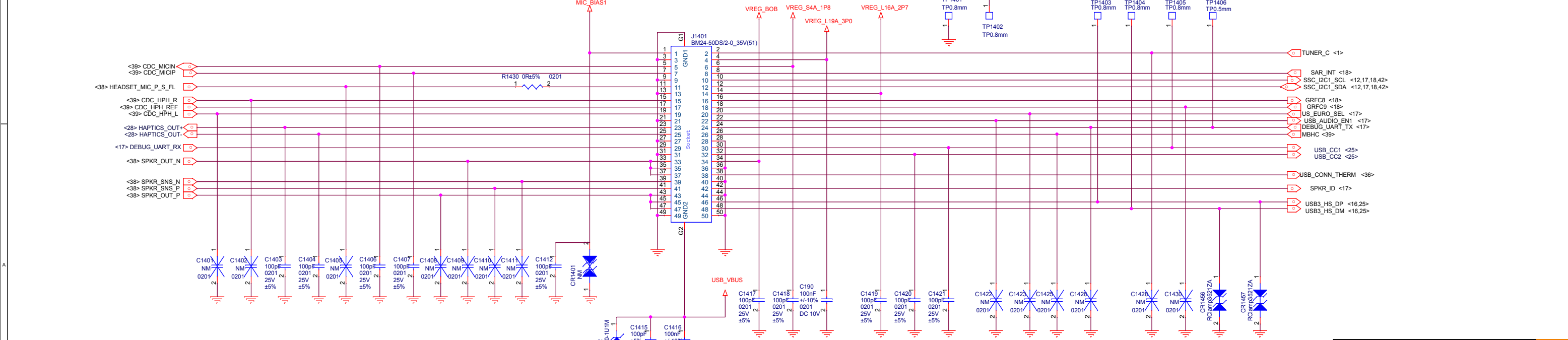

Title	E8	
Size	Document Number	Rev
A2	LCD&BTB	P0
Date:	Friday, March 23, 2018	Sheet 40 of 44

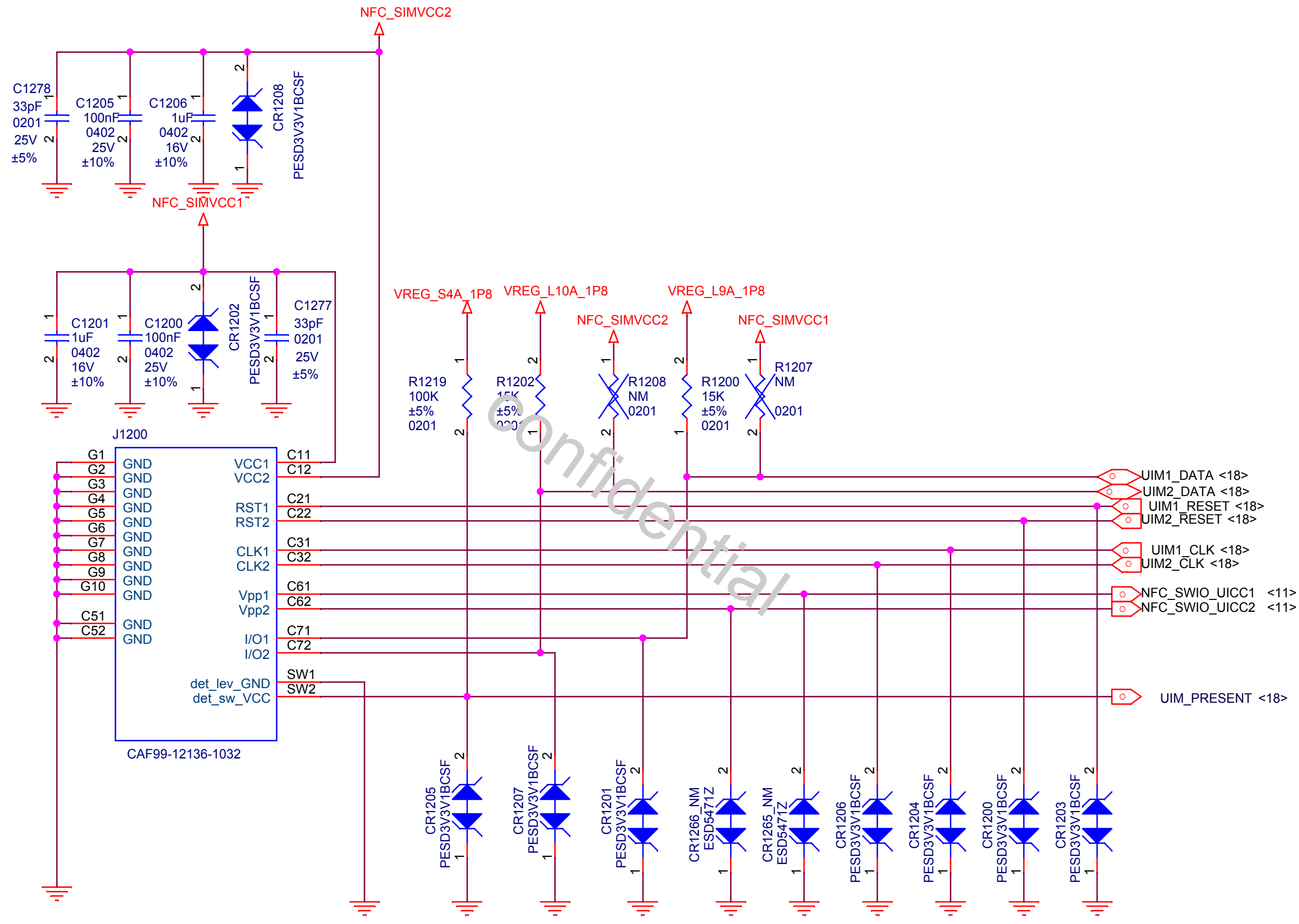

Title		
E8		
Size	Document Number	Rev
A4	SIM CONNECTOR	P0
Date:	Sheet	41 of 44

FINGERPRINT

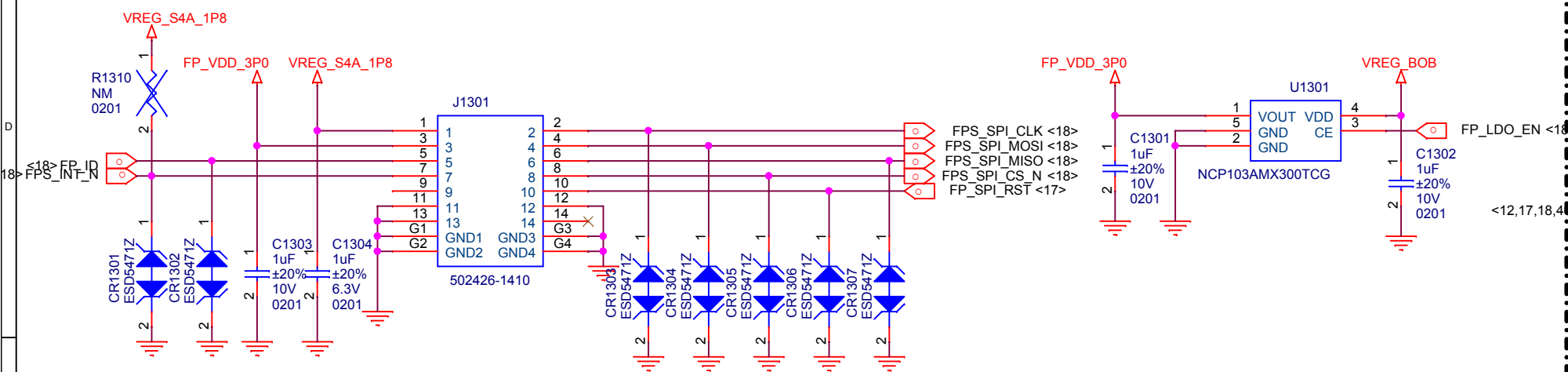

PRESSURE

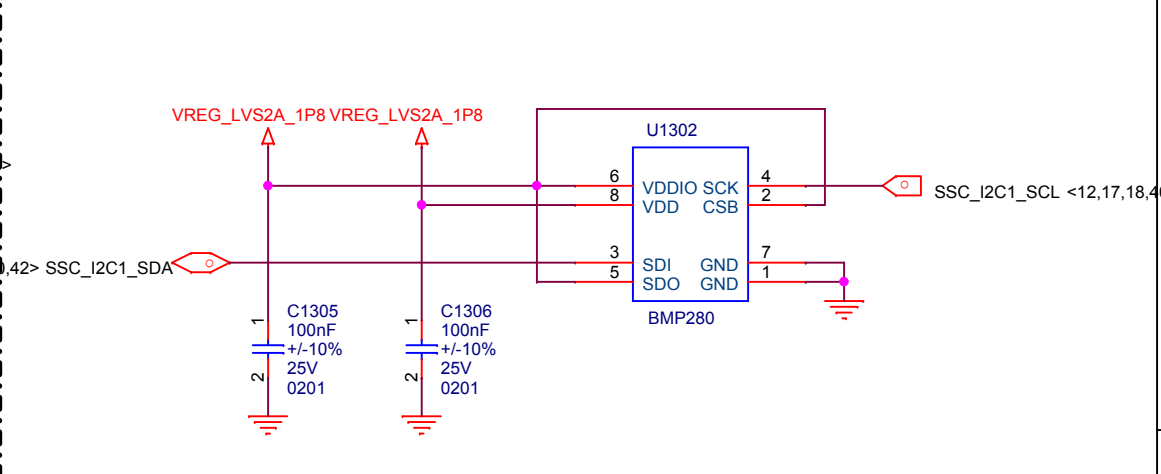

GYRO

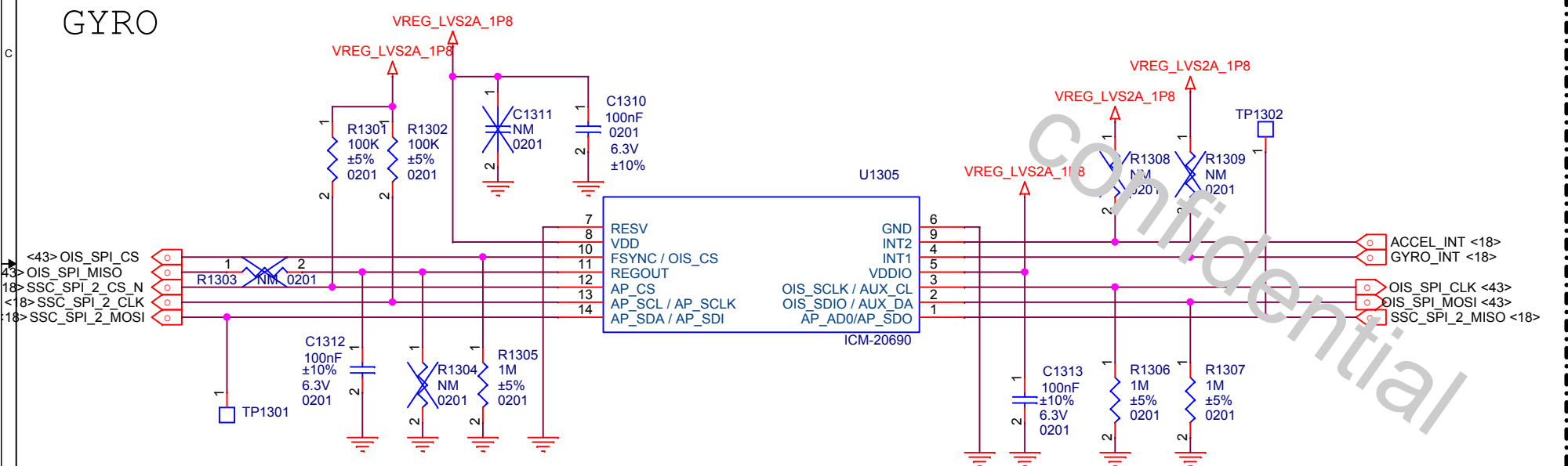

COMPASS

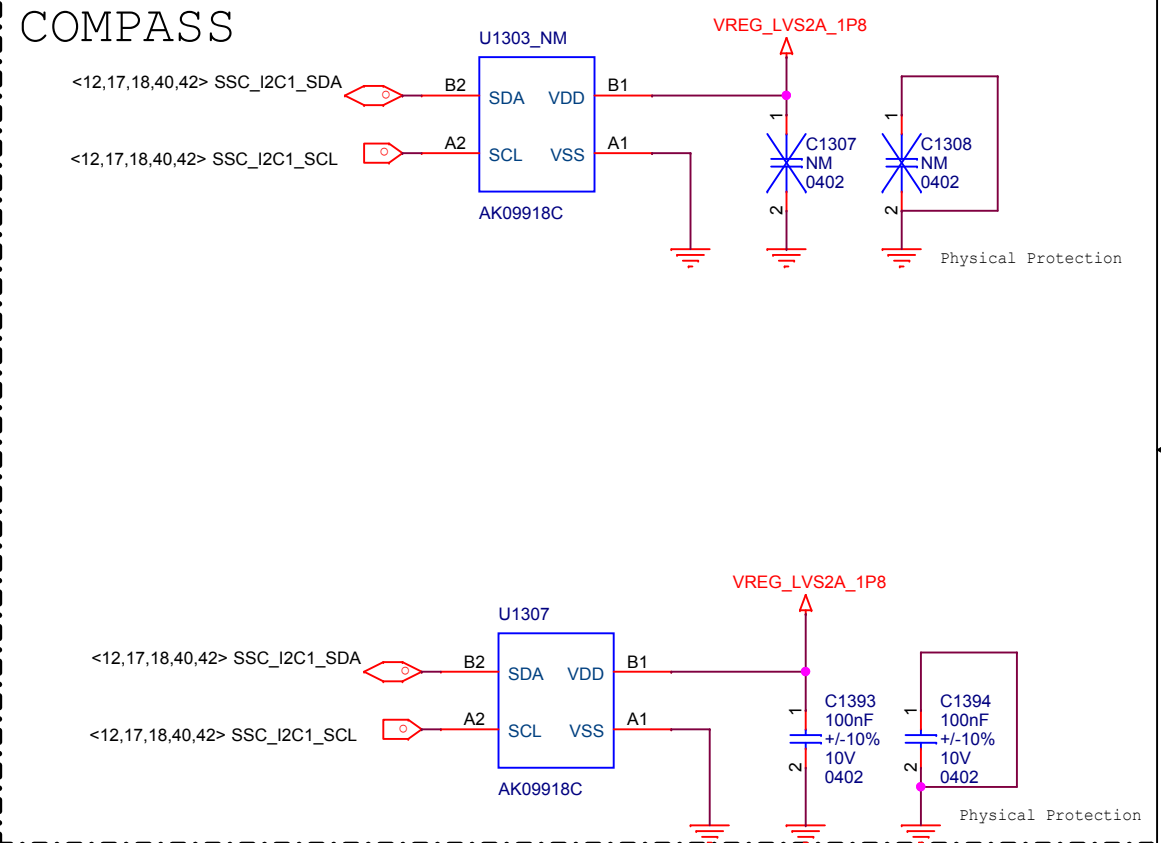

P-SENSOR

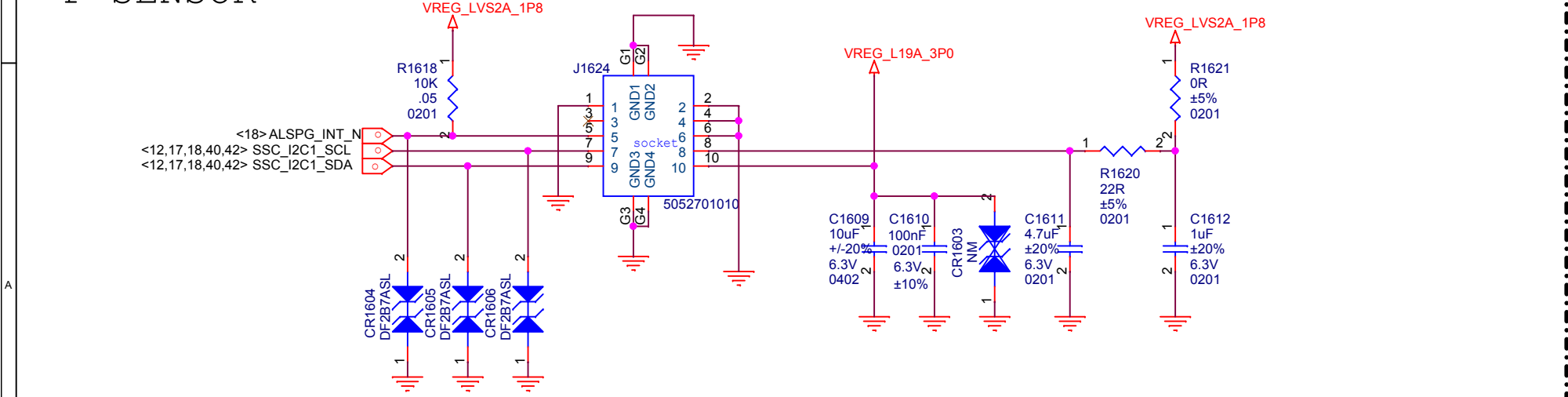

HALL

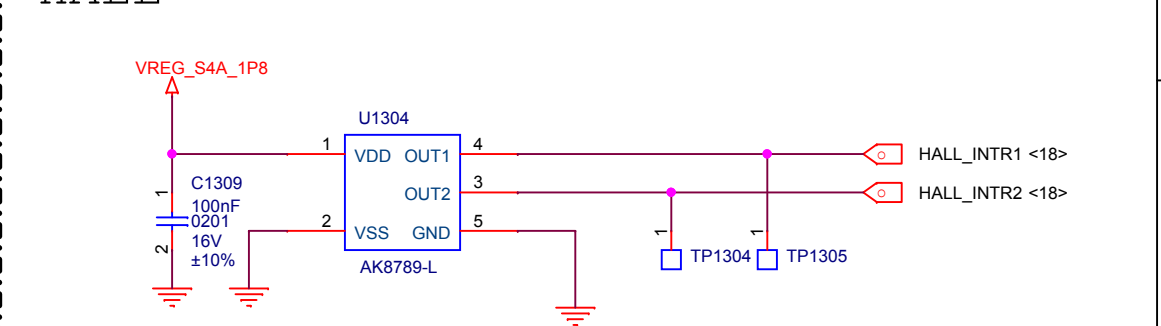

Title			E8	
Size	Document Number			
A3	SENSOR		Rev	P0
Date:	Sheet 42 of 44			

LDOs

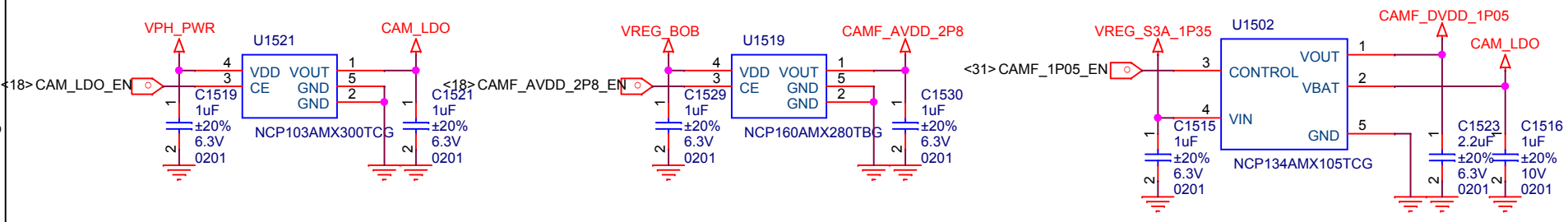

IR CAMERA

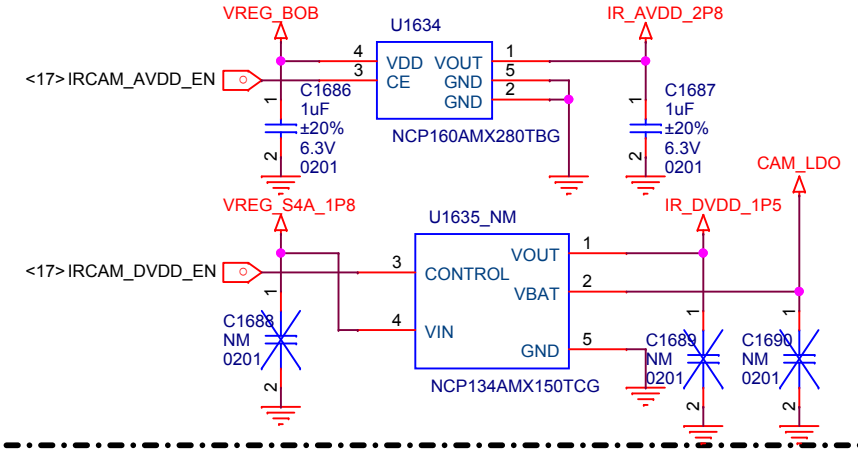

FRONT CAMERA

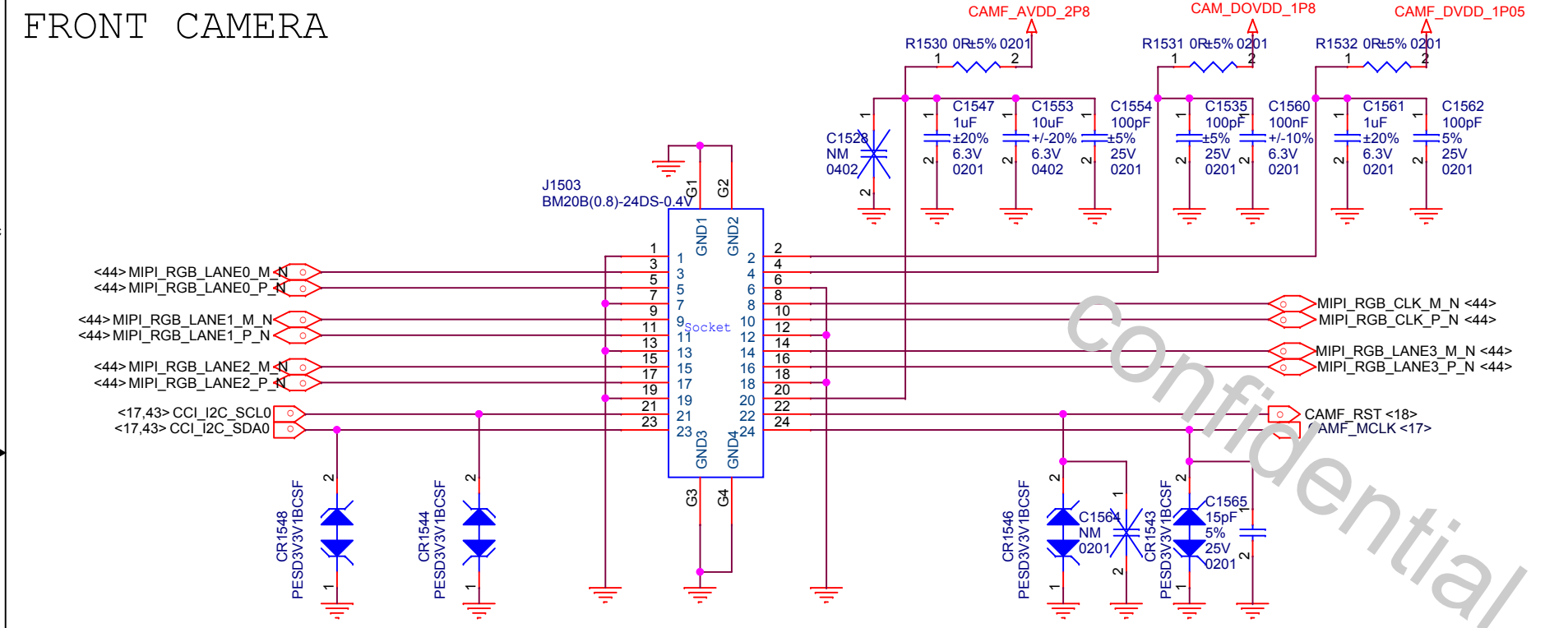

FRONT EMI

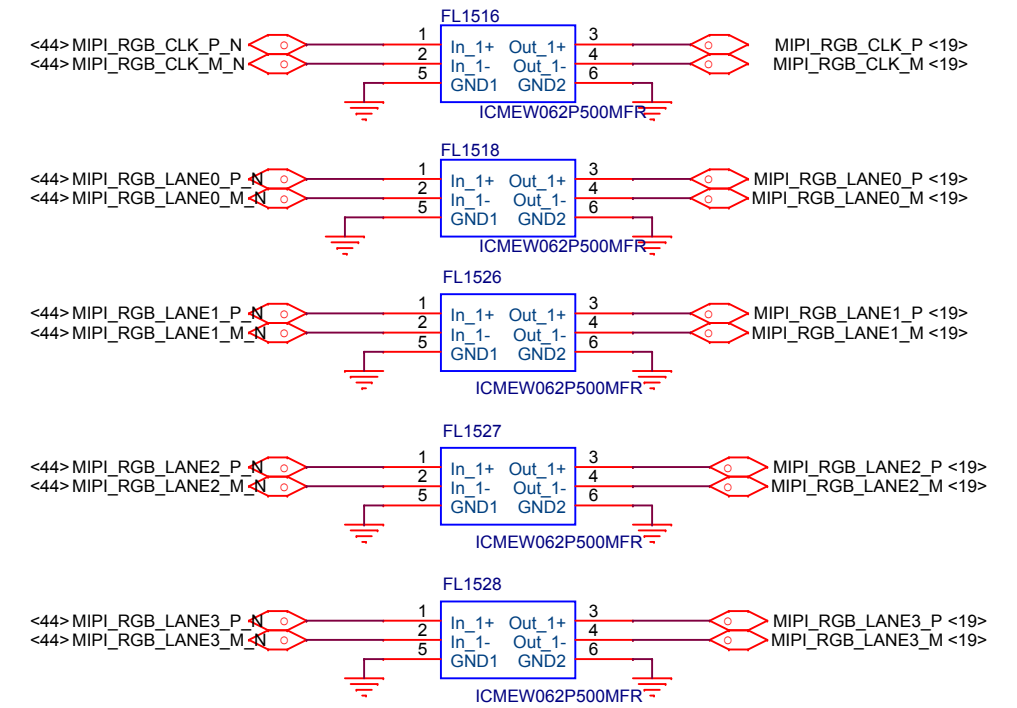

IR CAMERA

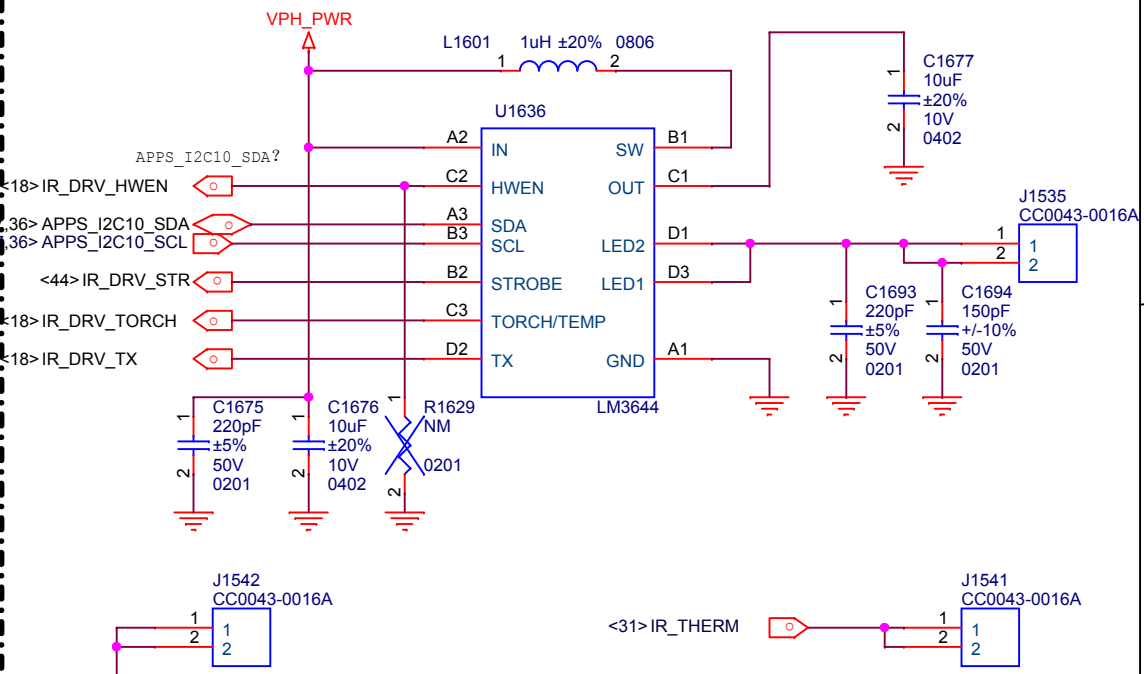
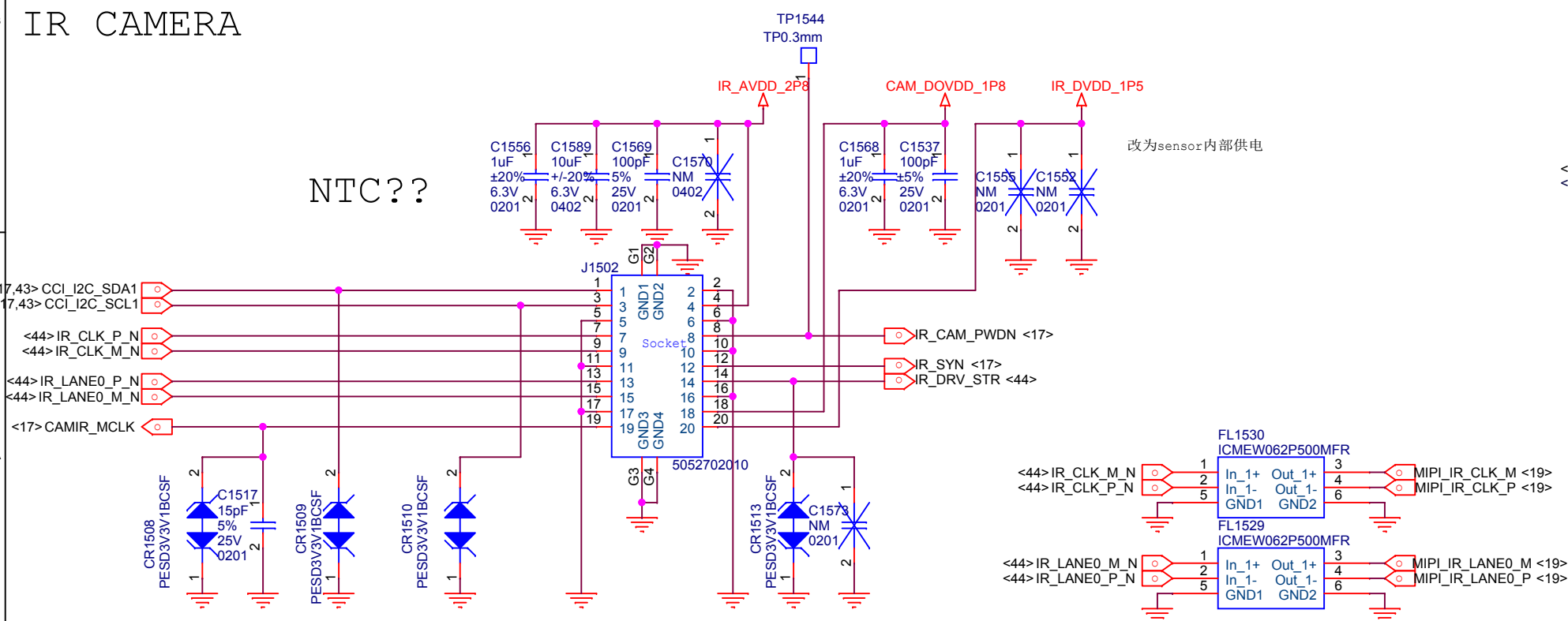

Title		E8	
Size	A3	Document Number	
Date:		Sheet	44 of 44

