

Ant Con&Coupler & Switchplexer

Title		
A1		
Size	Document Number	Rev
A3	<Doc>	P0
Date:	Wednesday, December 09, 2015	Sheet 1 of 37

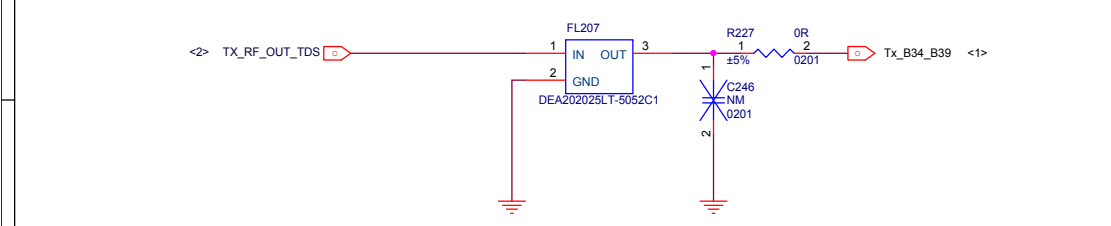

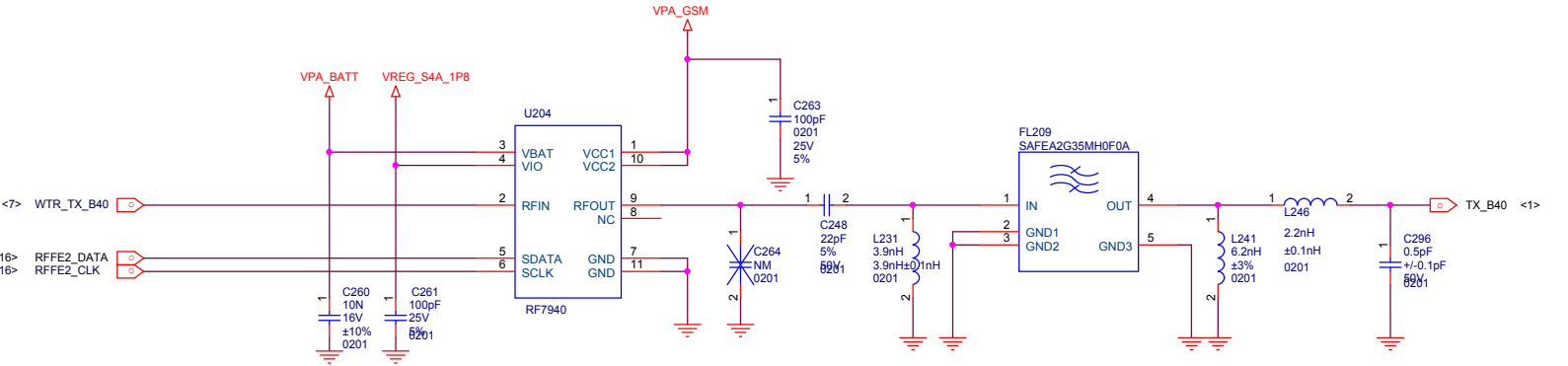
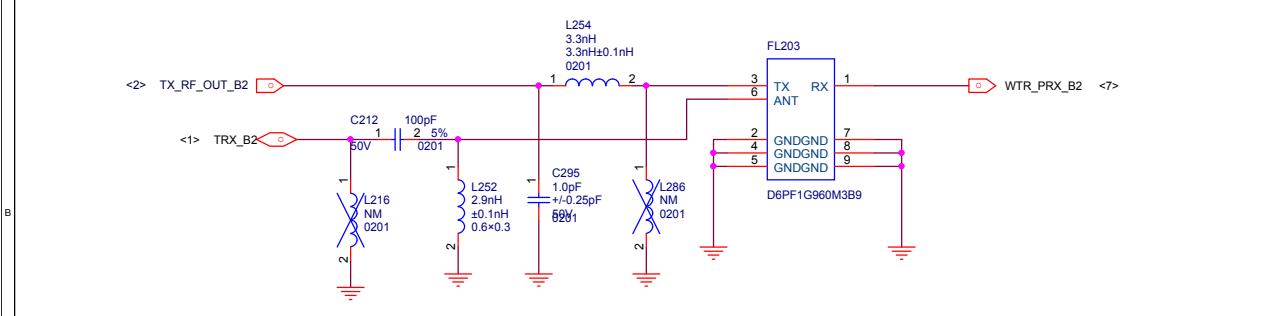
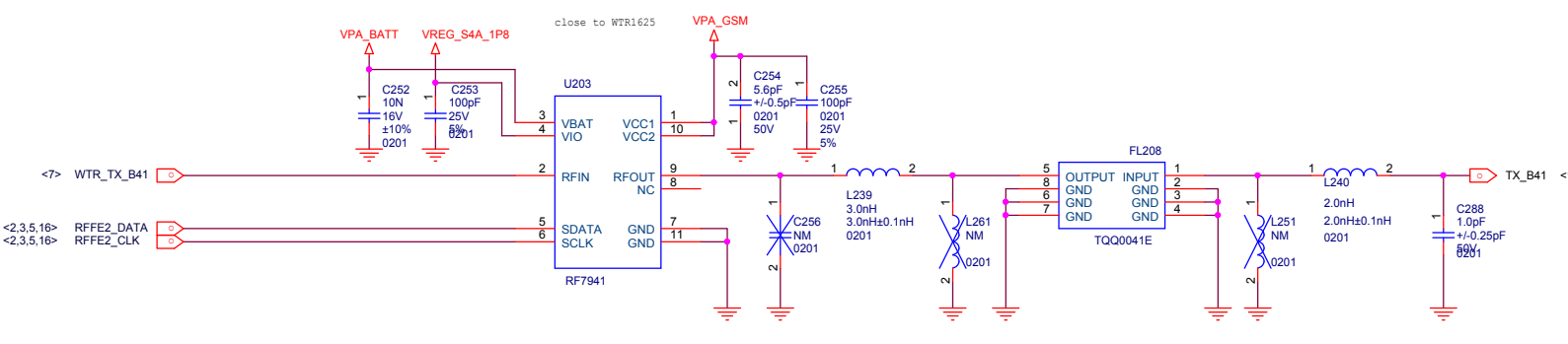
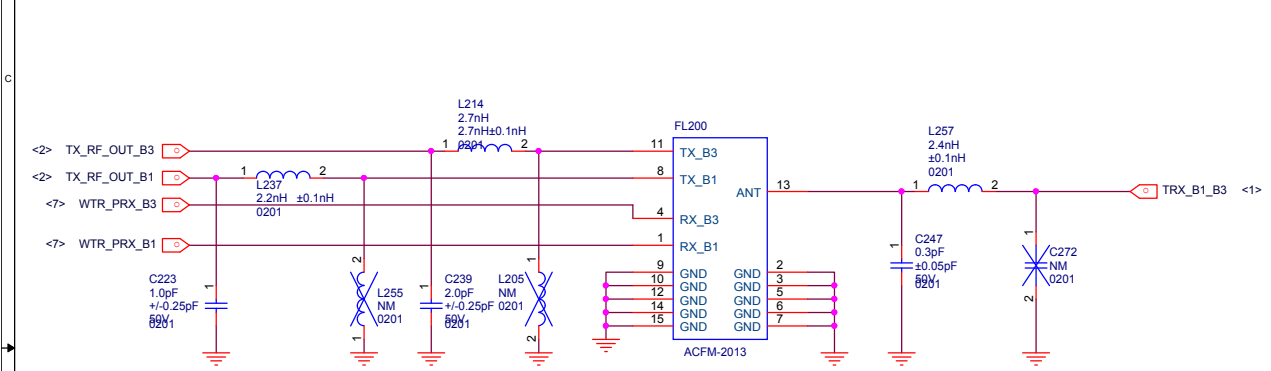
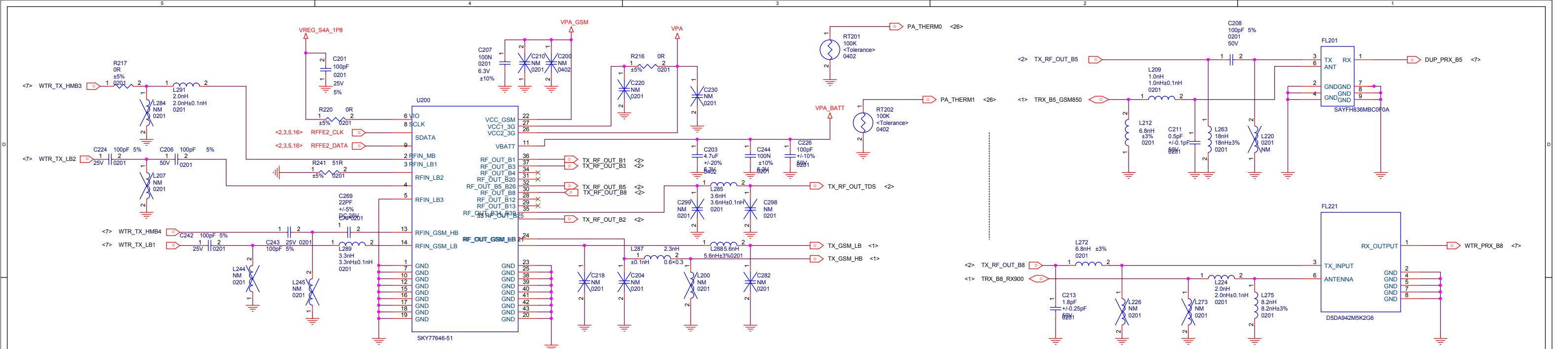
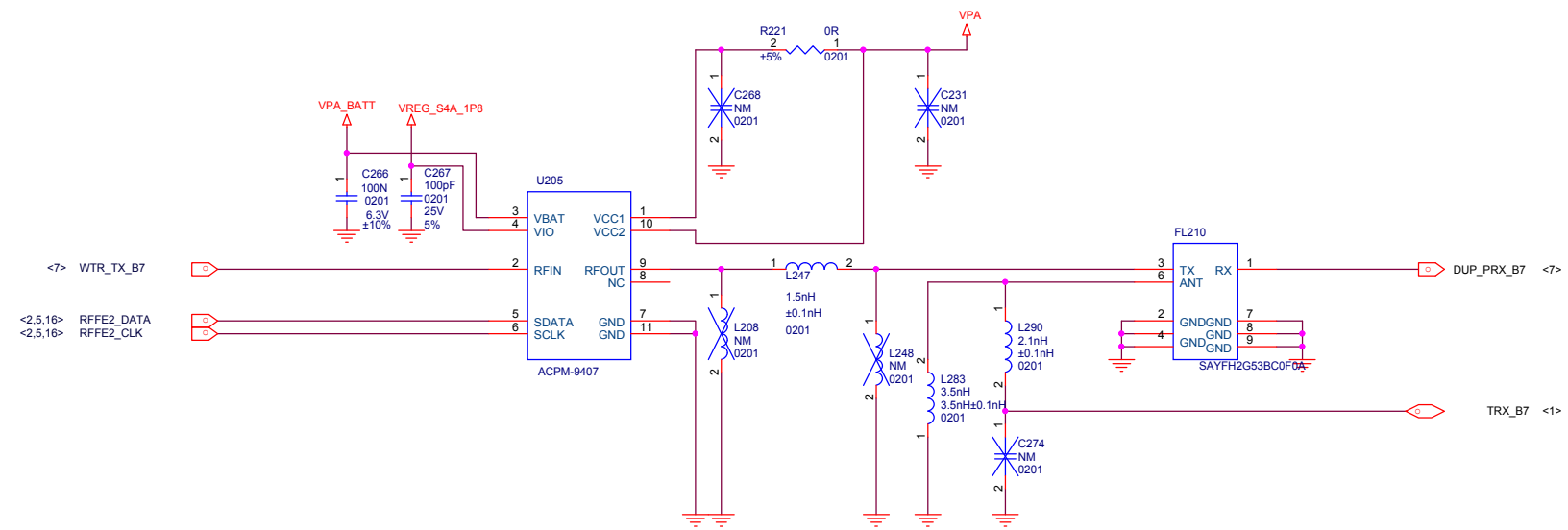

BAND7

Title			A1
Size			<Doc>
A2	Document Number		Rev P0
Date:	Wednesday, December 09, 2015	Sheet	3 of 37

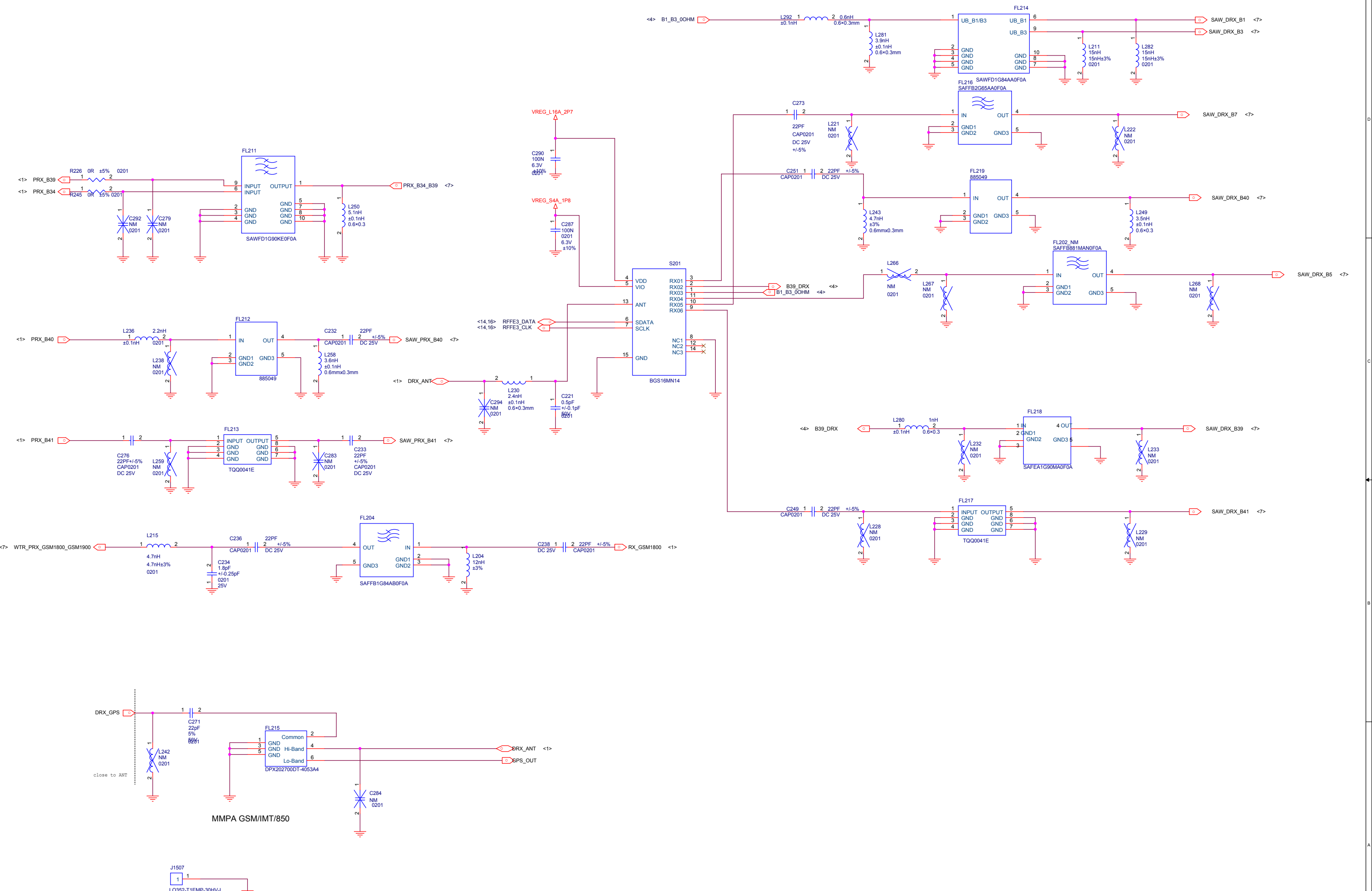

MMPA GSM/IMT/850

J1507
L0352-T1EMP-30HV-L

TX FILTERS&GSM1800&DRX_B			
Title	A1		
Size	<Doc>		
A2	Document Number		Rev P0
Date:	Wednesday, December 09, 2015	Sheet	4 of 37

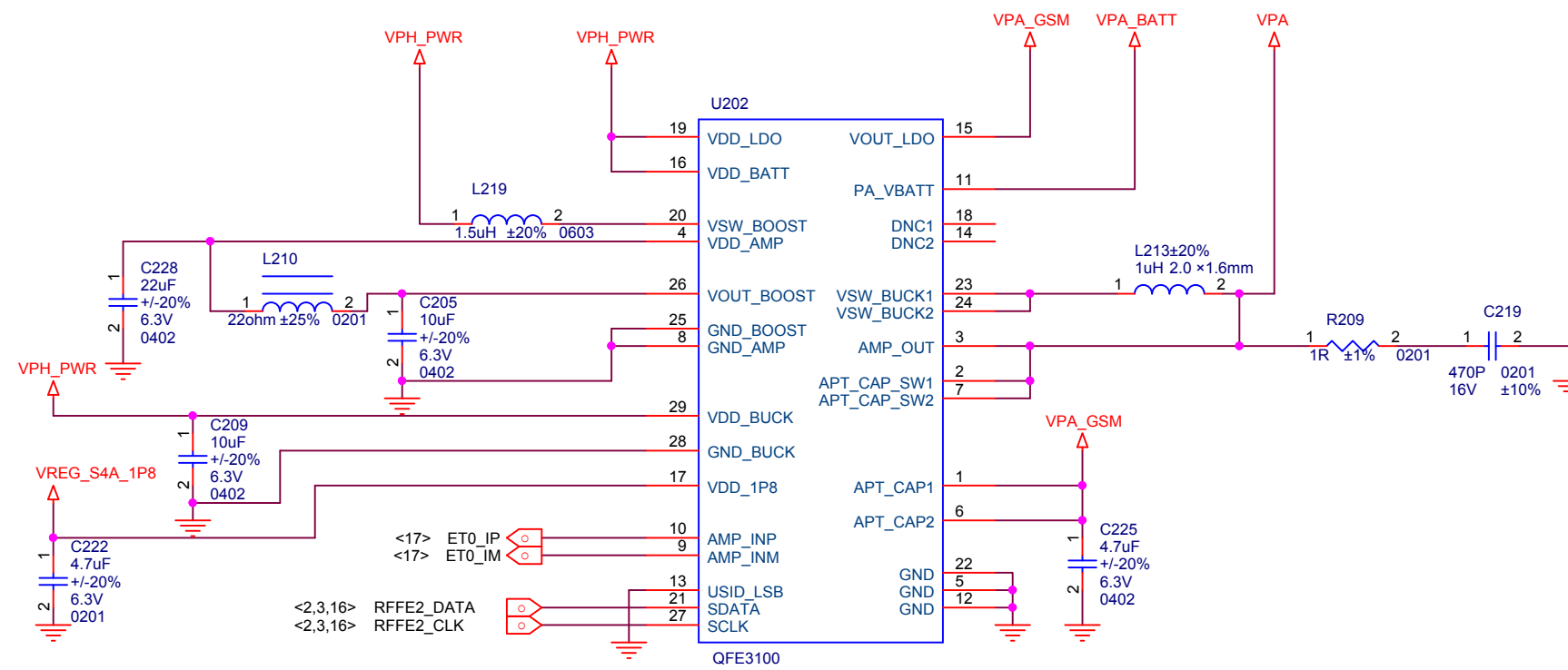

QFE3100

Title		
A1		
Size	Document Number	Rev
A3	<Doc>	P0
Date:	Wednesday, December 09, 2015	Sheet 5 of 37

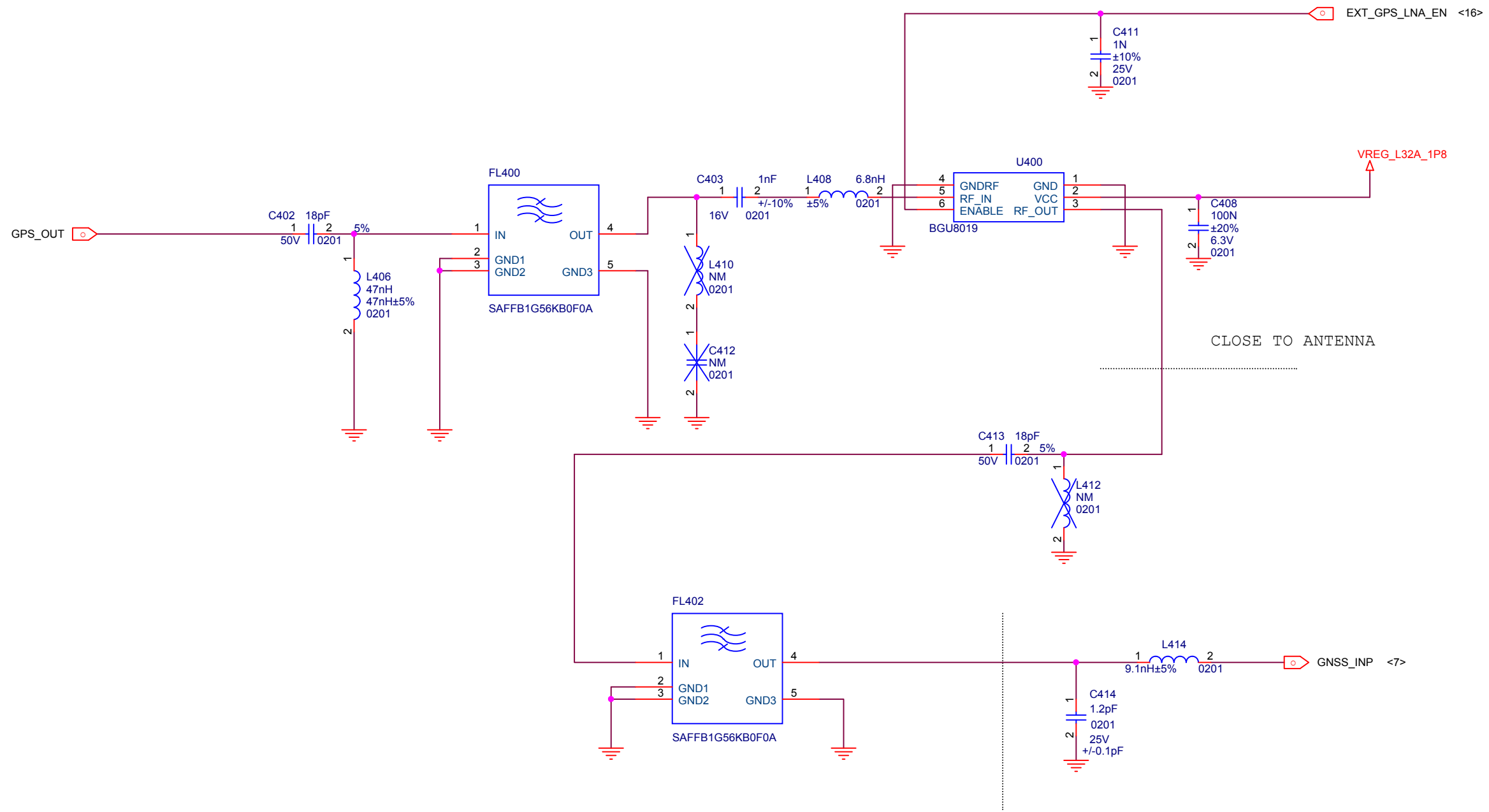

GPS

Title		
A1		
Size	Document Number	Rev
A3	<Doc>	P0
Date:	Wednesday, December 09, 2015	Sheet 6 of 37

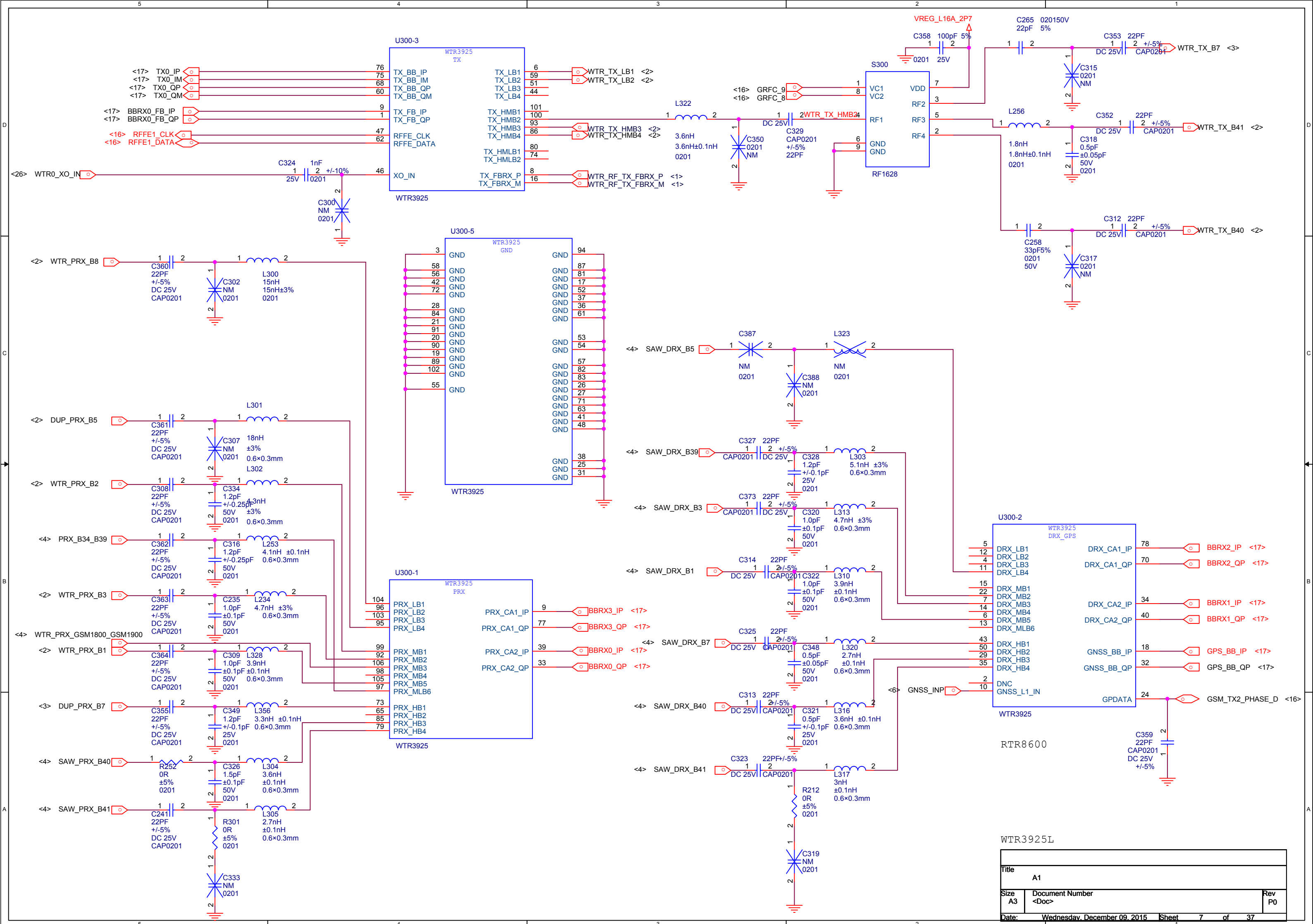

Title		
A1		
Size	Document Number	Rev
A3	<Doc>	P0
Date:	Wednesday, December 09, 2015	Sheet 7 of 37

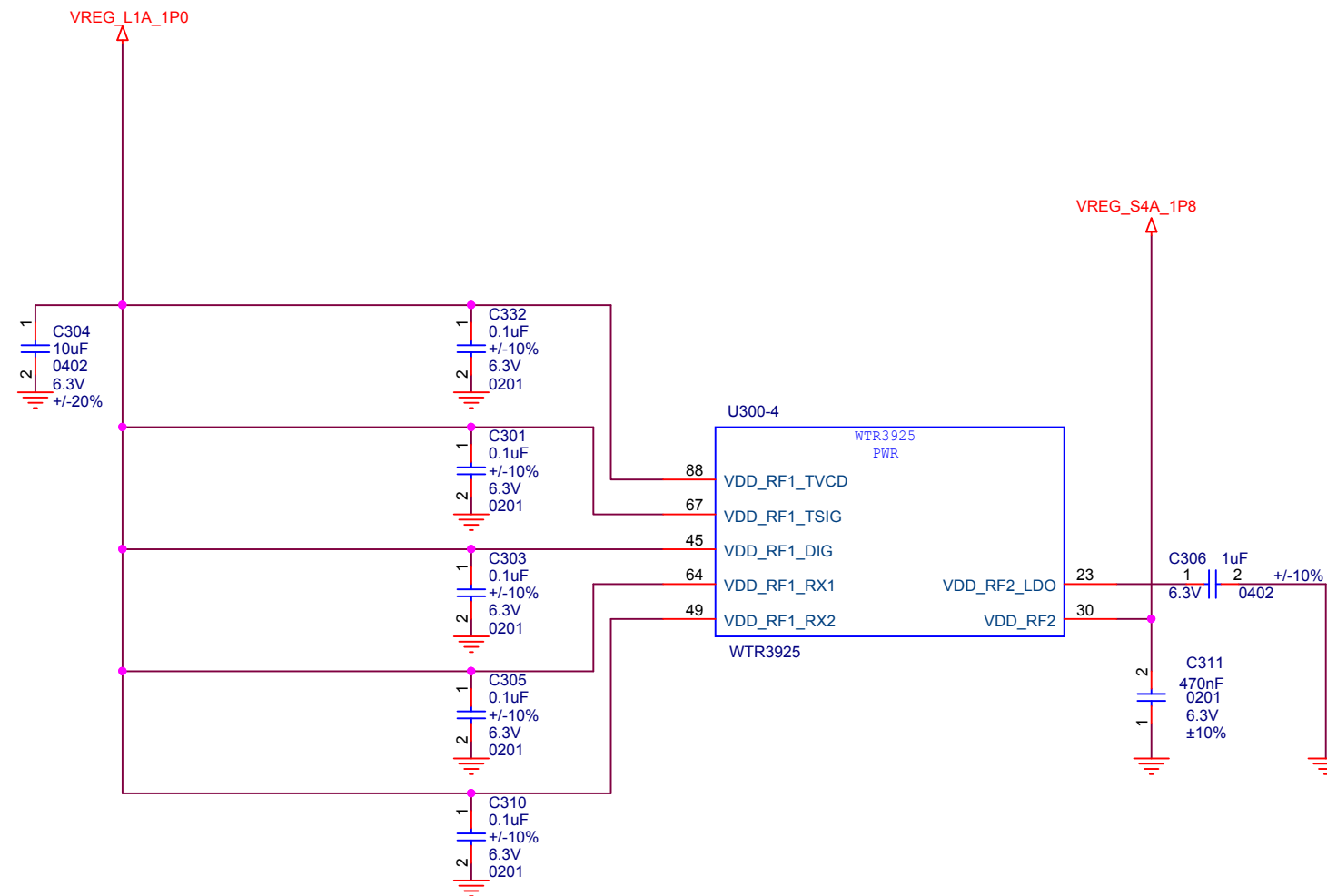

WTR3925L BYPASS

Title		
A1		
Size	Document Number	Rev
A3	<Doc>	P0
Date:	Wednesday, December 09, 2015	Sheet 8 of 37

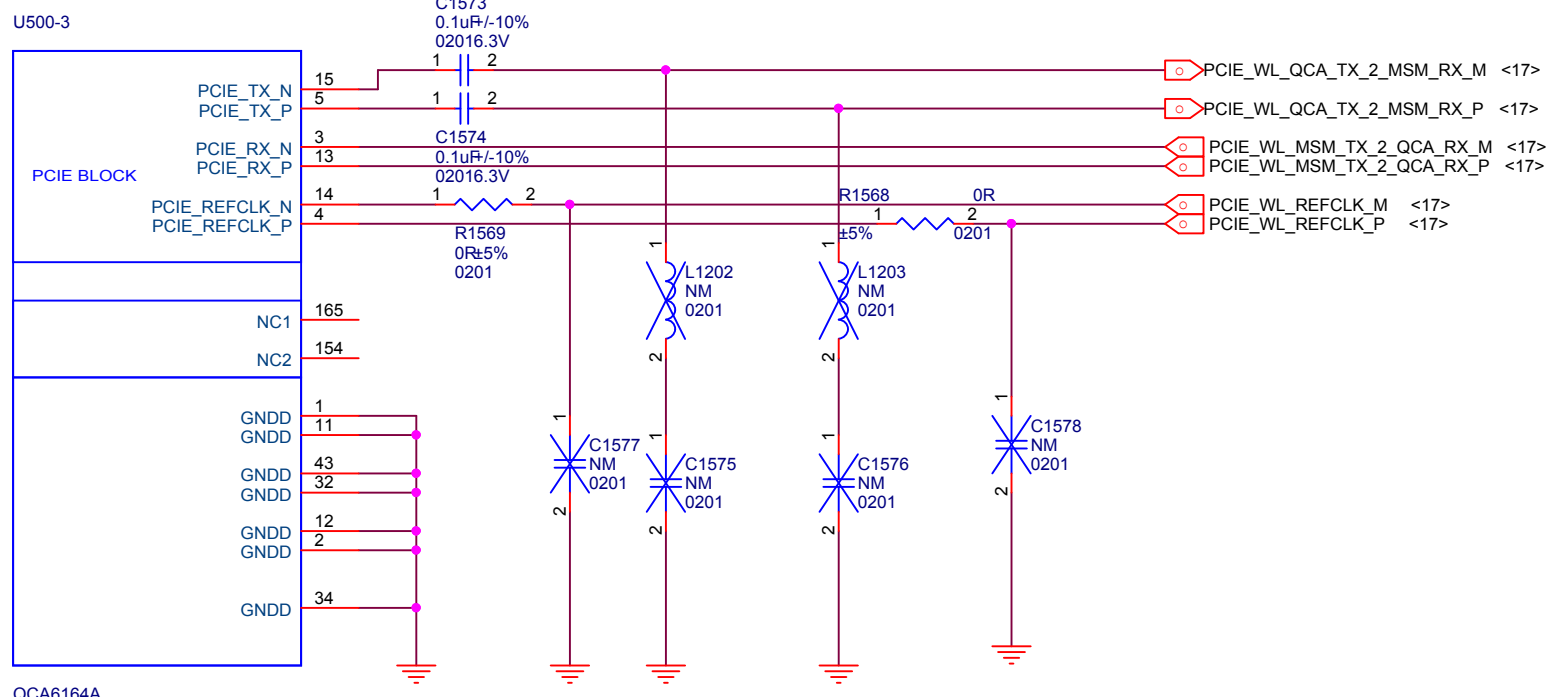
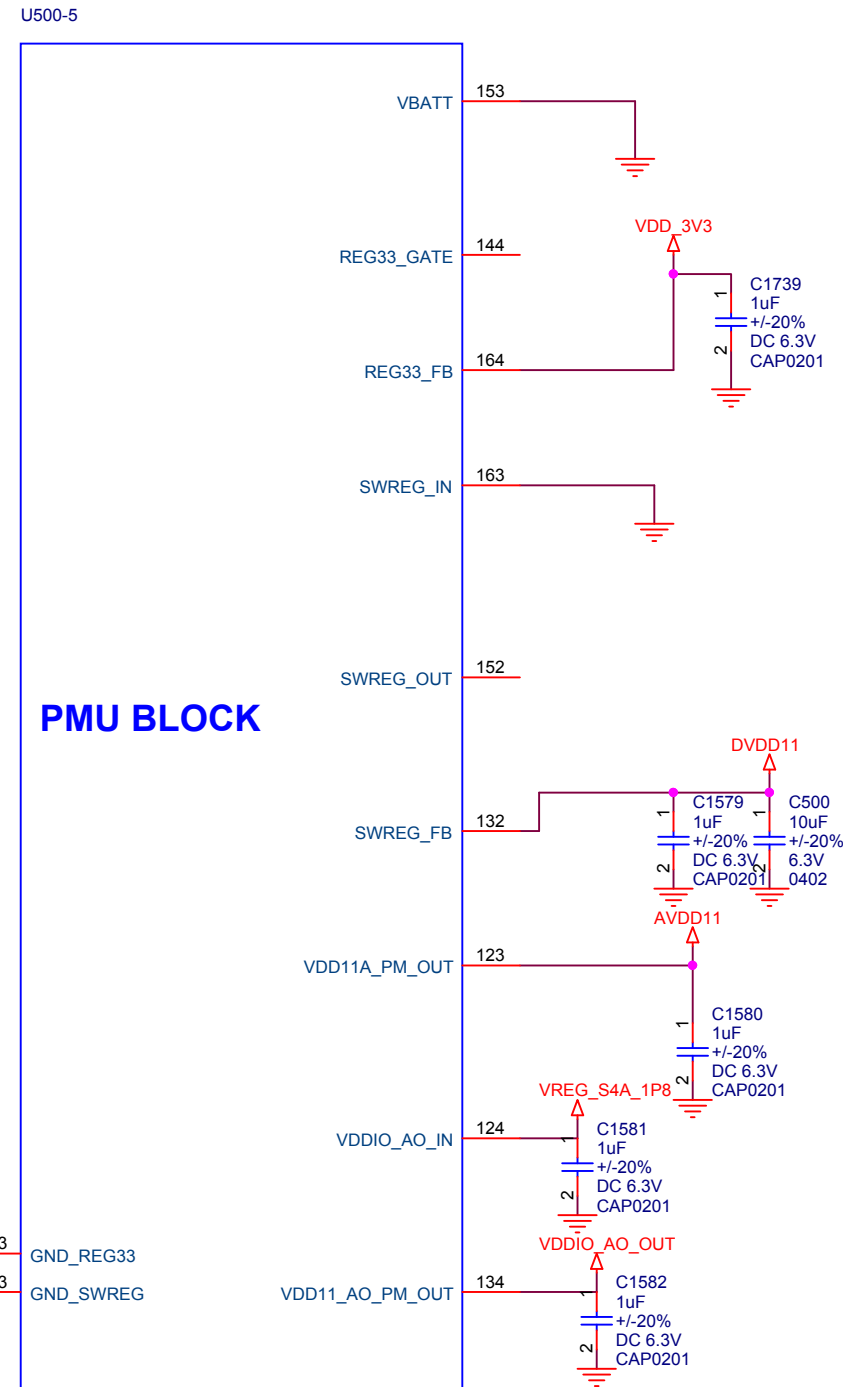
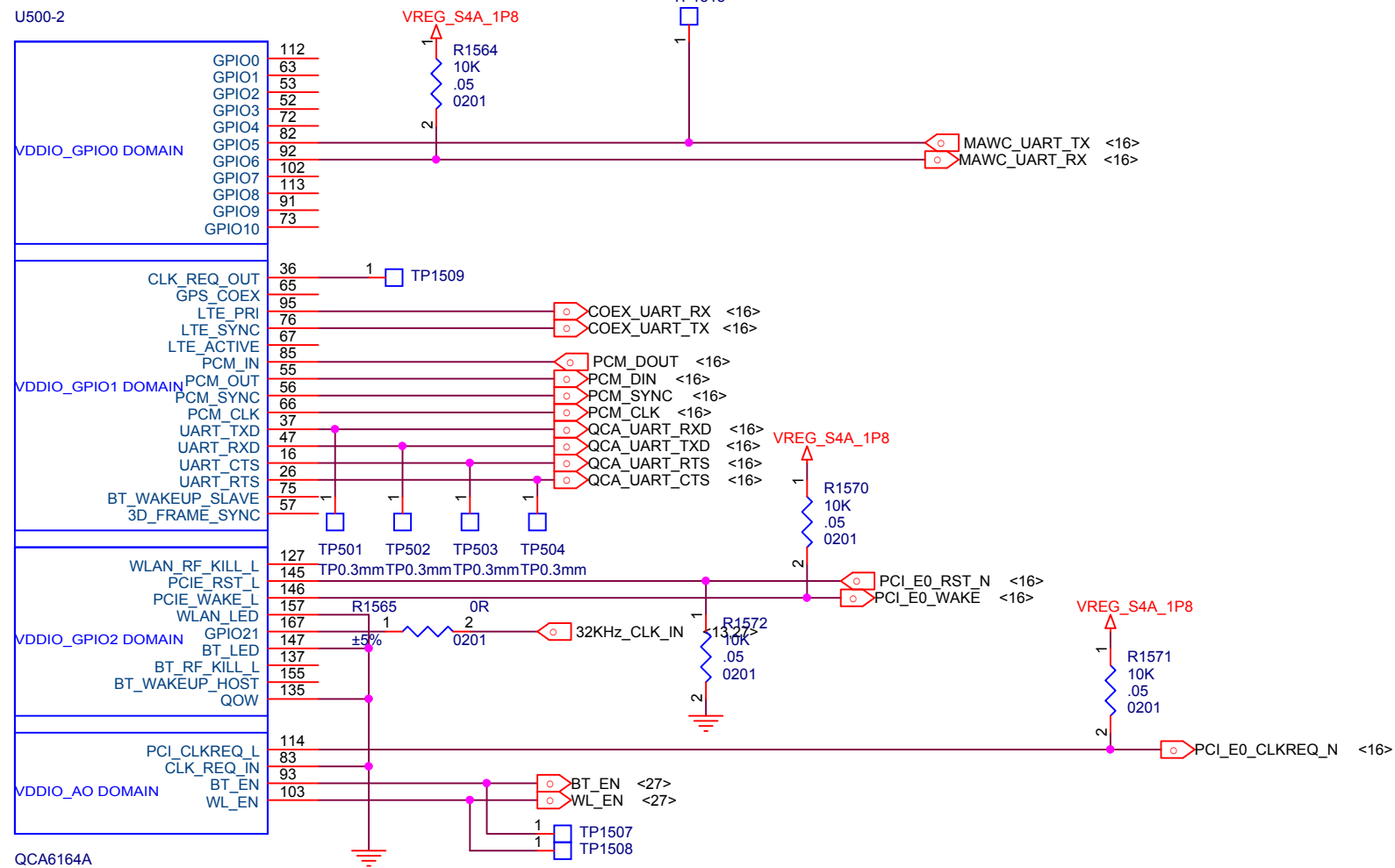

WIFI INTERFACE

Title		
A1		
Size	Document Number	Rev
A3	<Doc>	P0
Date:	Wednesday, December 09, 2015	Sheet 9 of 37

POWER

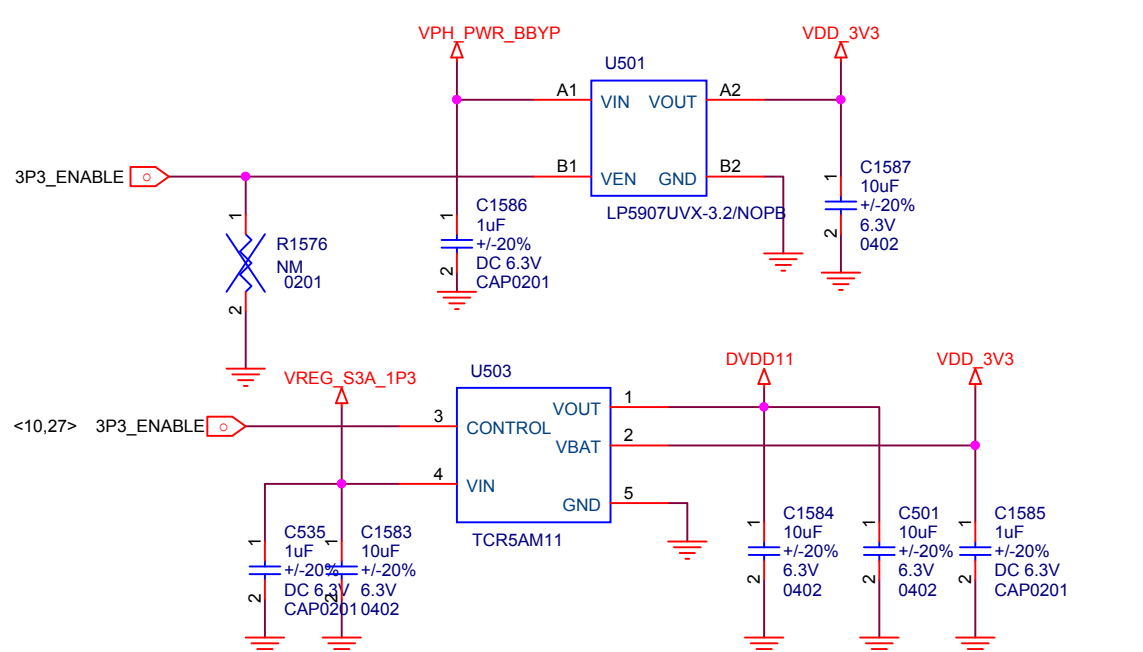
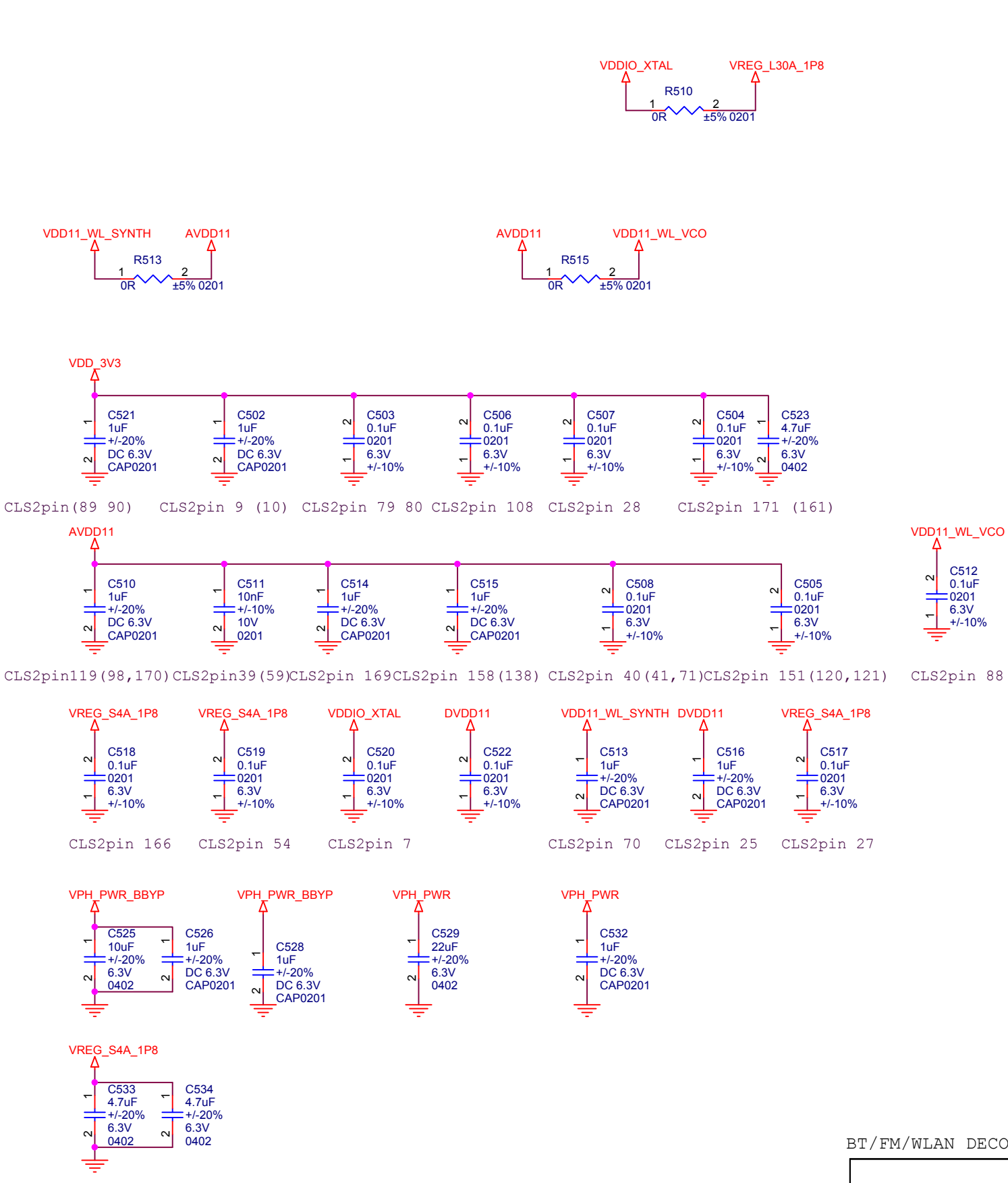
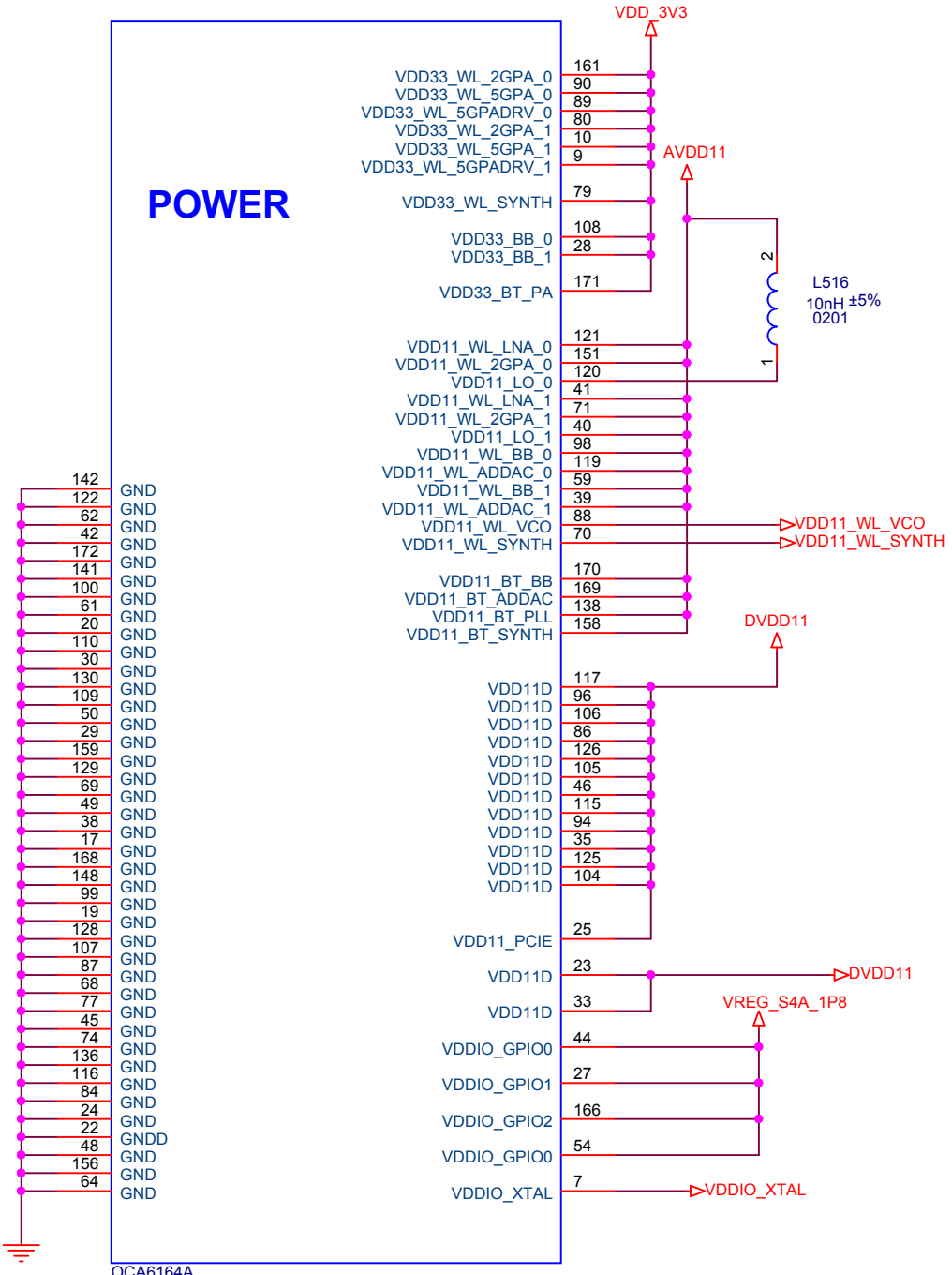

BT/FM/WLAN DECOUP

Title		A1
Size	Document Number	Rev
A3	<Doc>	P0
Date:	Wednesday, December 09, 2015	Sheet 10 of 37

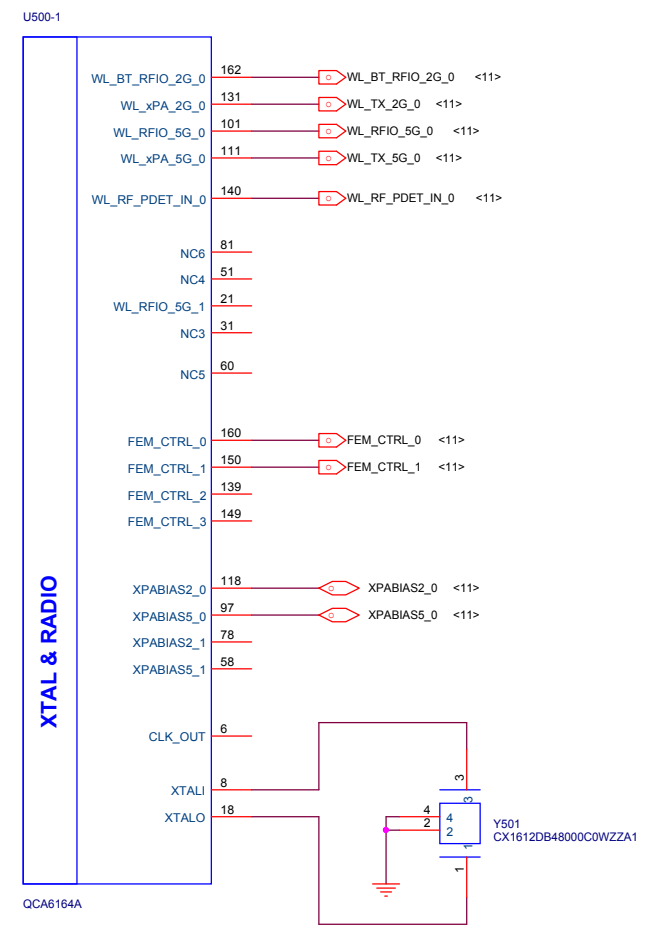
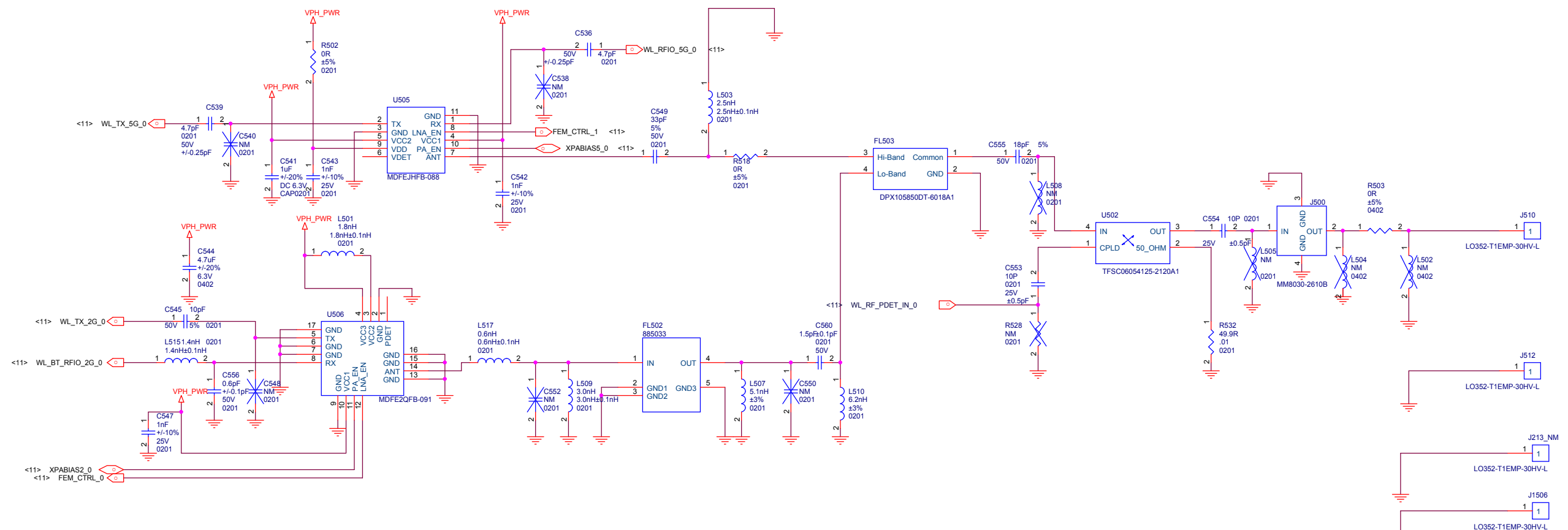

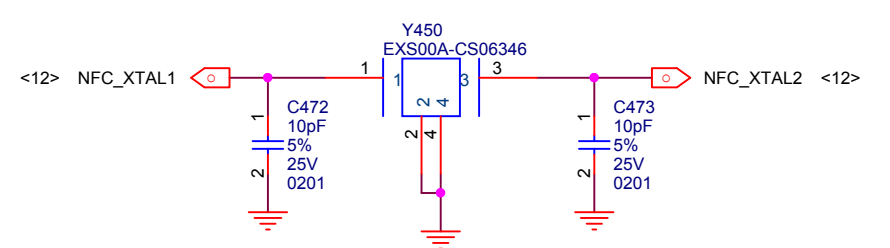
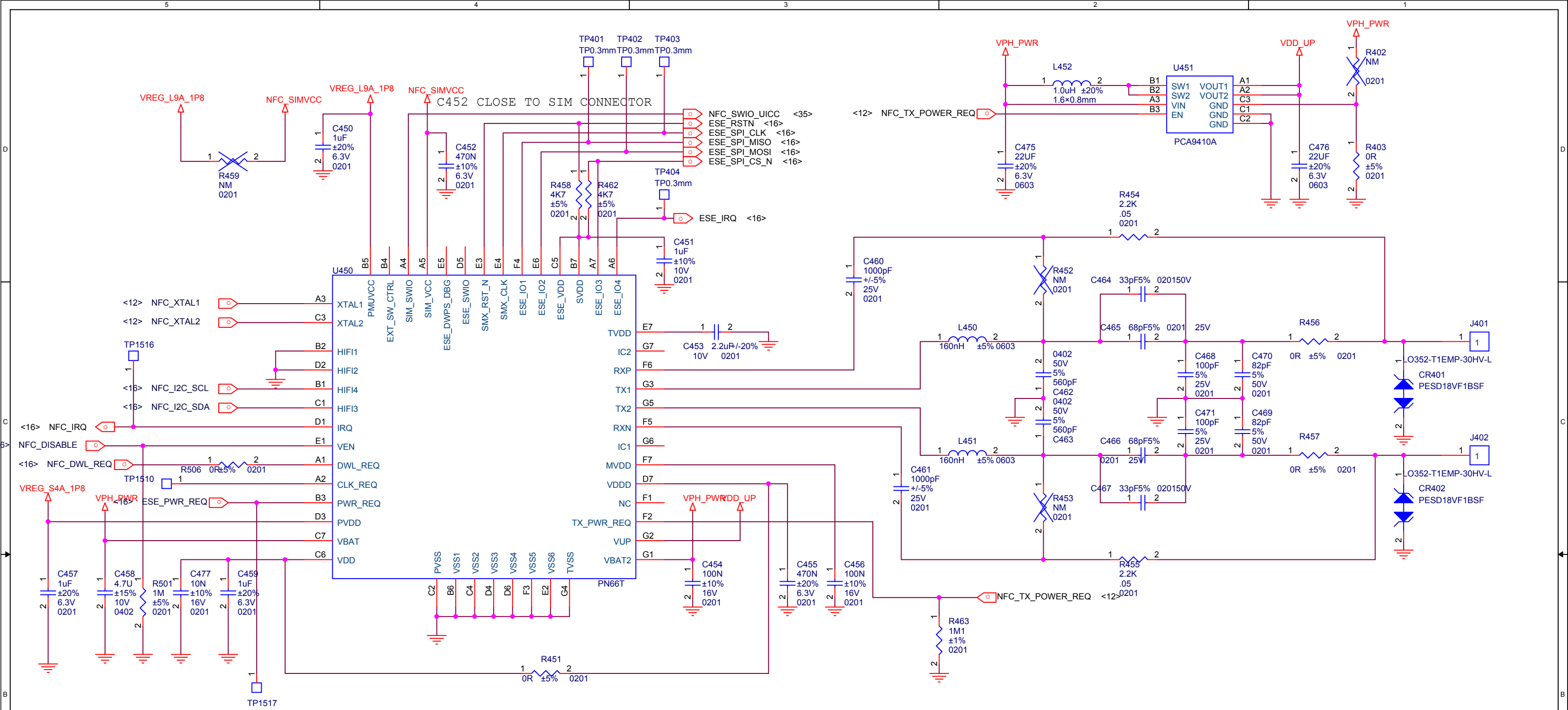

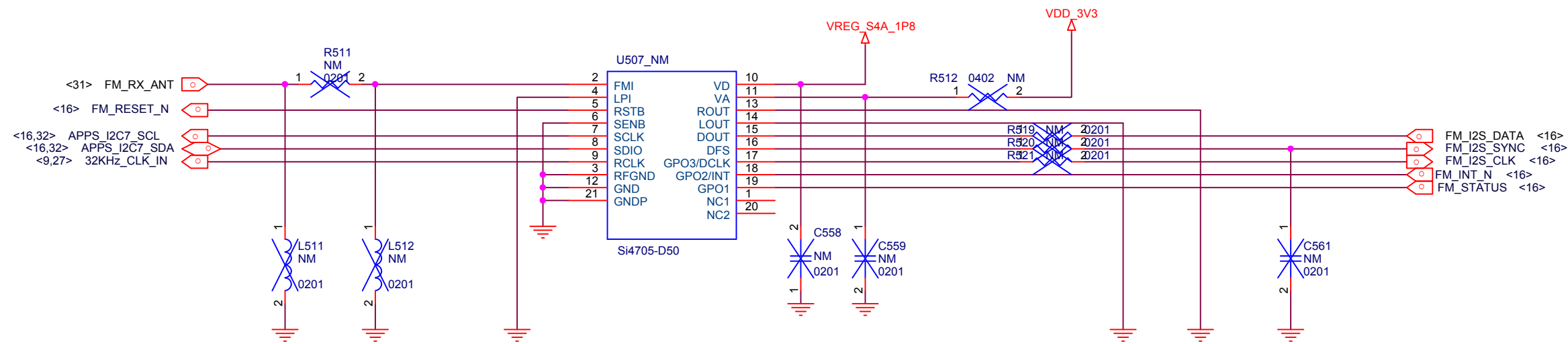

FM

Title		
A1		
Size	Document Number	Rev
A3	<Doc>	P0
Date:	Wednesday, December 09, 2015	Sheet 13 of 37

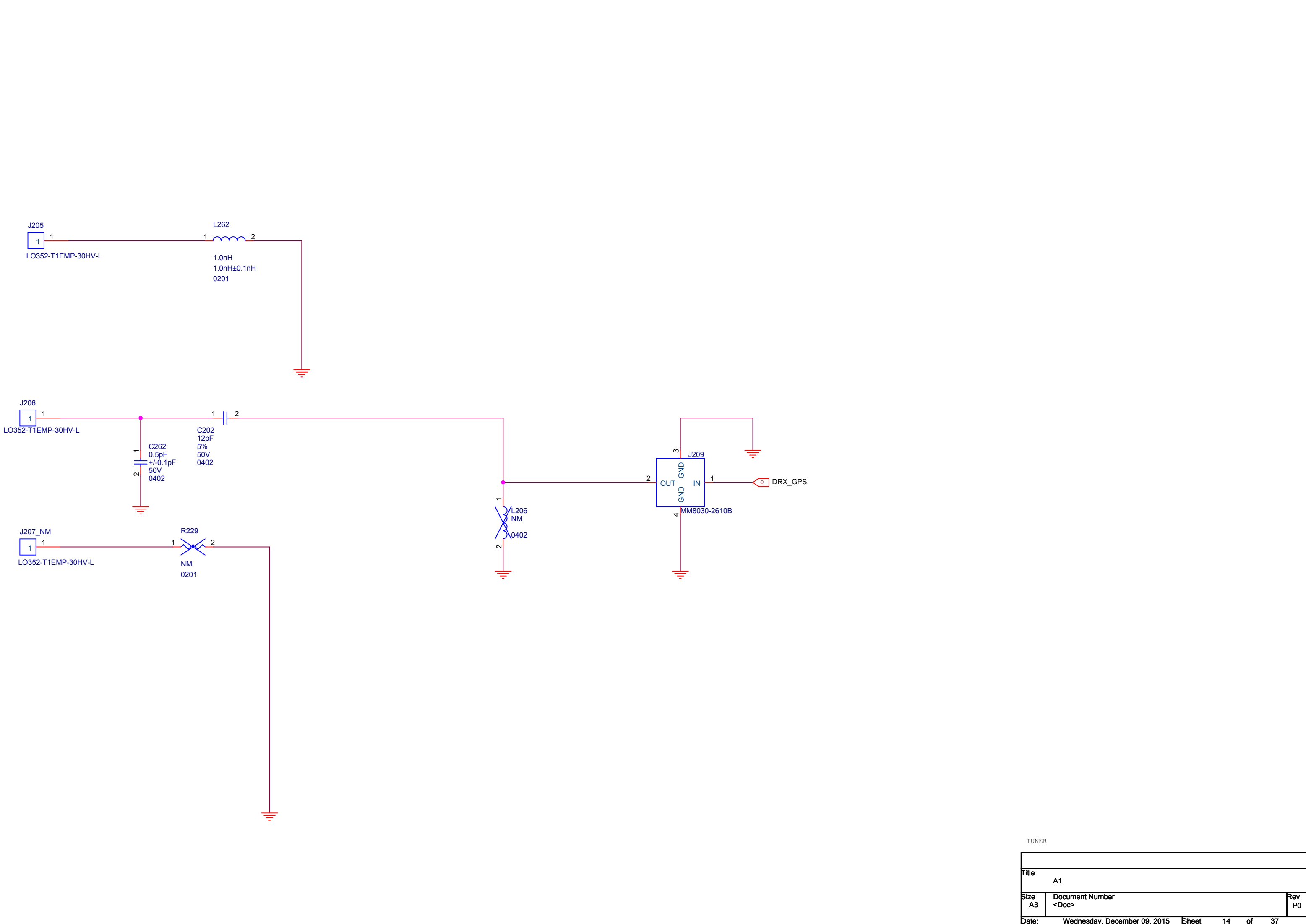

TUNER

Title		
A1		
Size	Document Number	Rev
A3	<Doc>	P0
Date:	Wednesday, December 09, 2015	Sheet 14 of 37

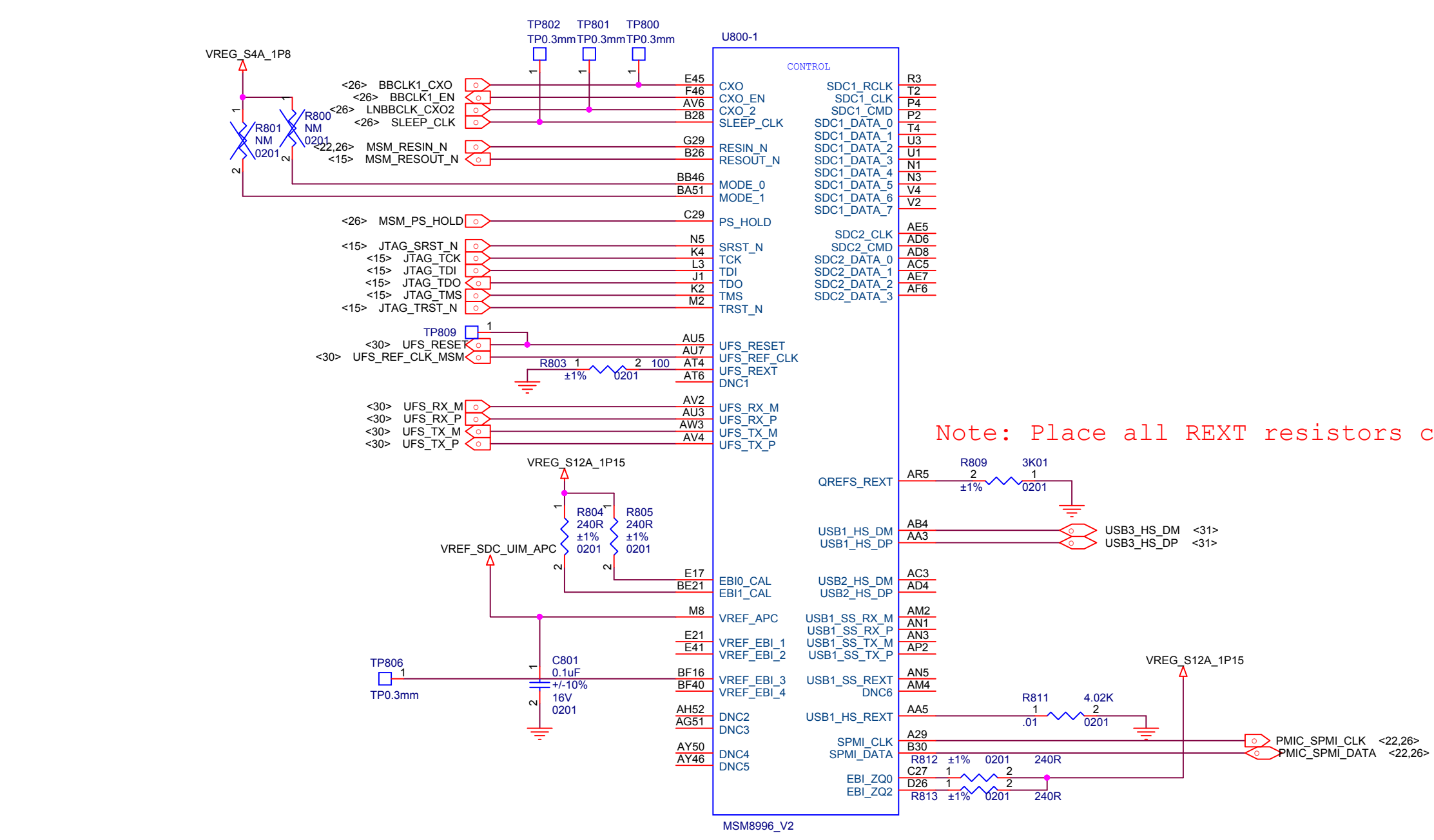

Note: Place all REXT resistors close to MSM

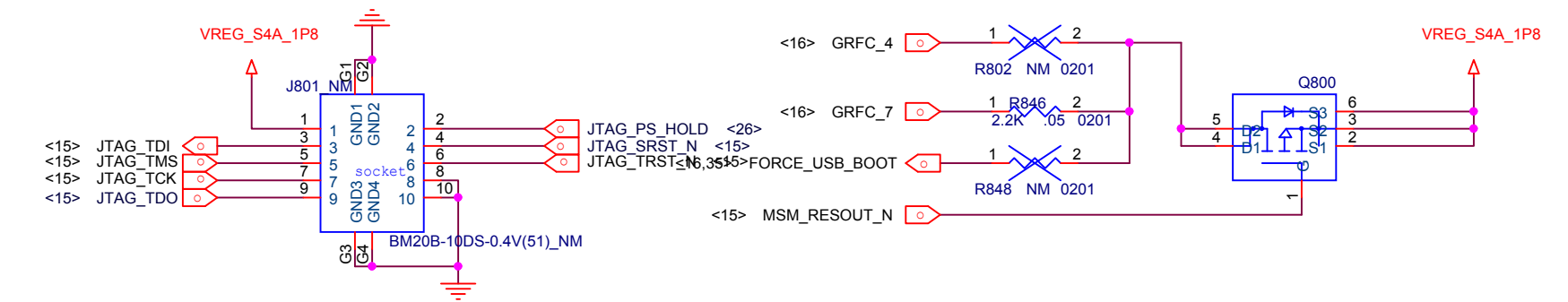

MSM8996 CONTROL

Title		
A1		
Size	Document Number	Rev
A3	<Doc>	P0
Date:	Wednesday, December 09, 2015	Sheet 15 of 37

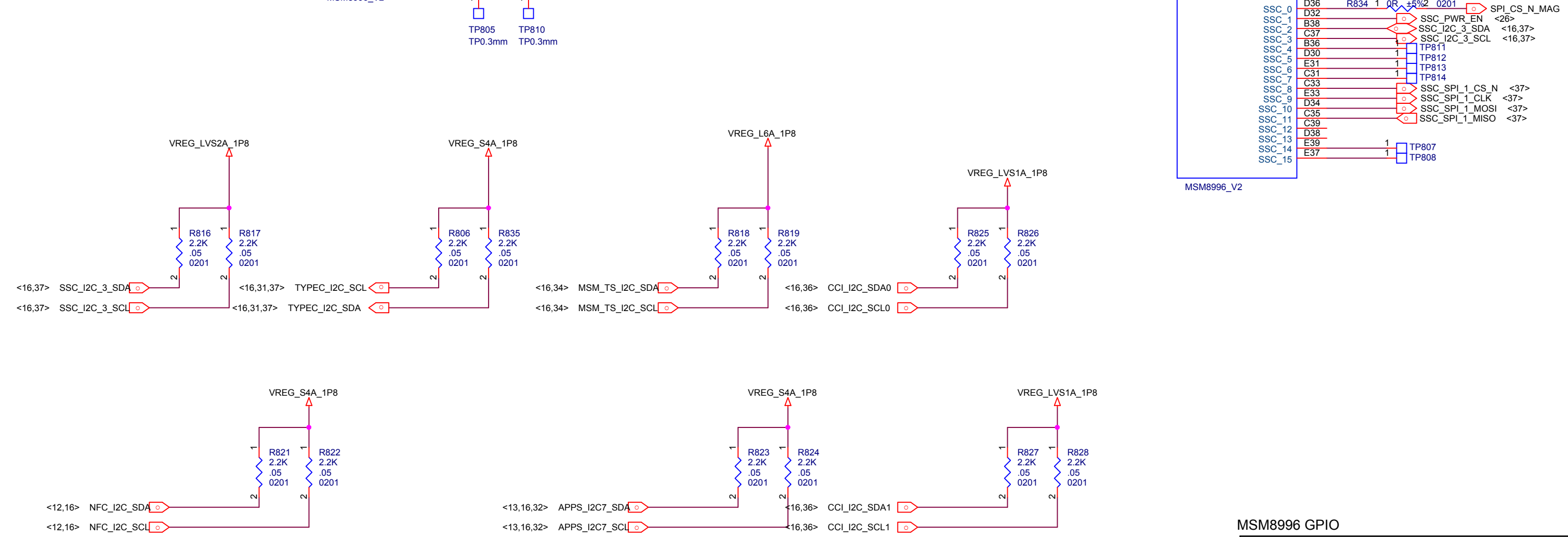
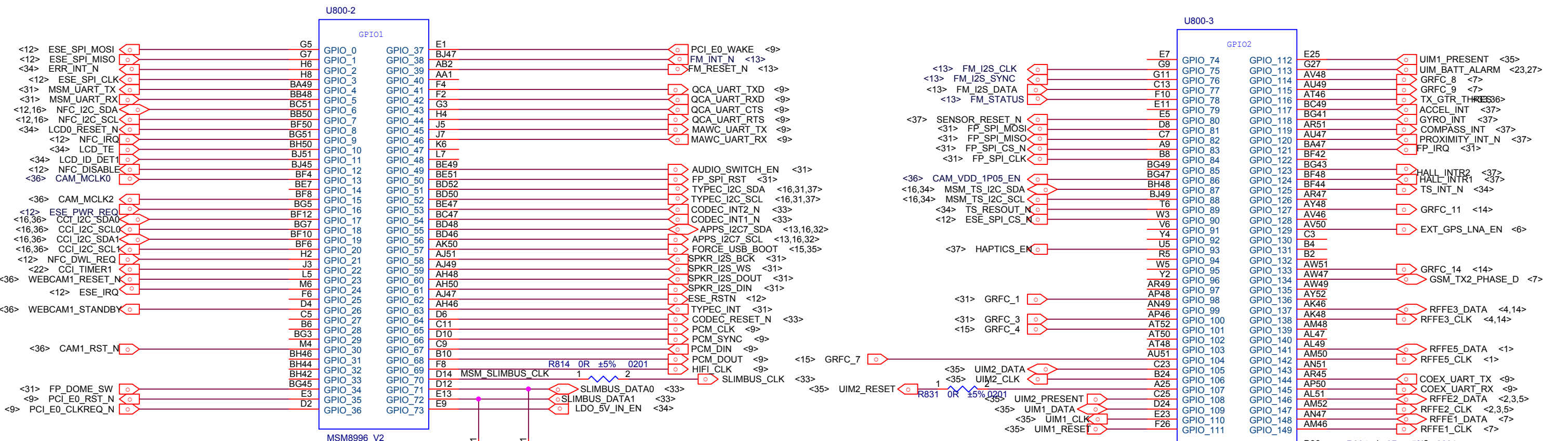

MSM8996 GPIO

Title		
A1		
Size	Document Number	Rev
A3	<Doc>	P0
Date:	Wednesday, December 09, 2015	Sheet 16 of 37

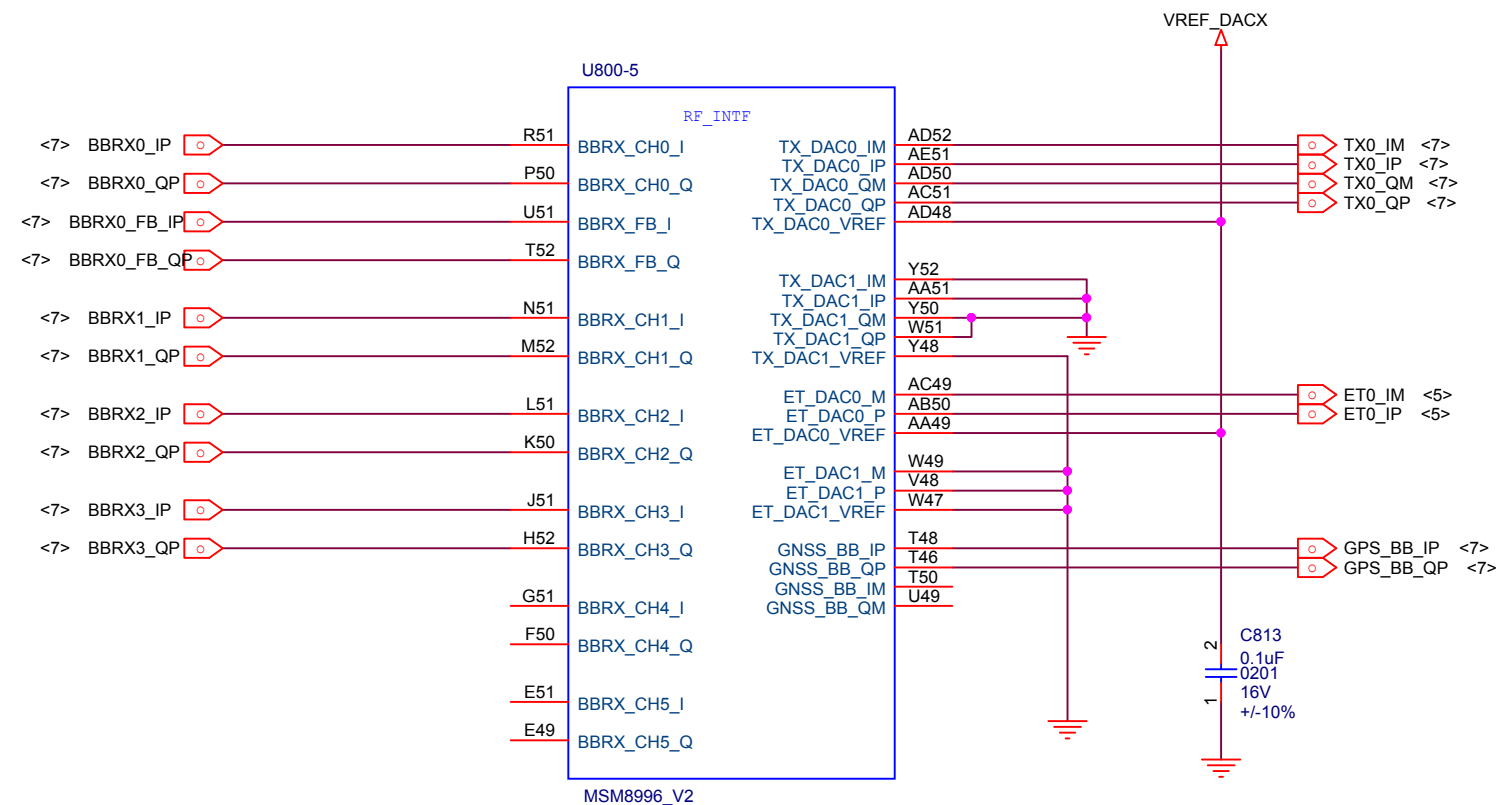
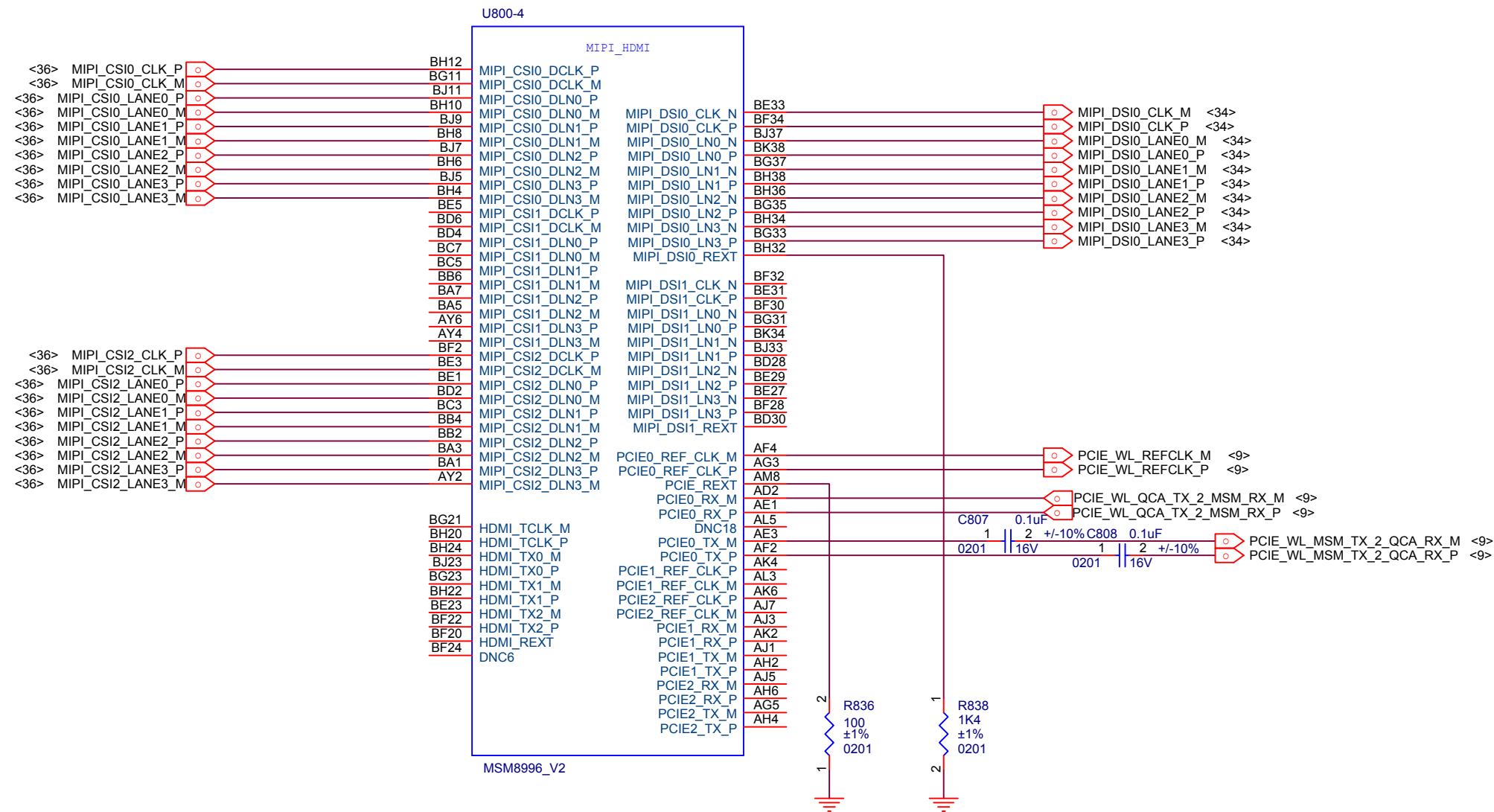

MSM8996 MIPI

Title		
A1		
Size	Document Number	Rev
A3	<Doc>	P0
Date:	Wednesday, December 09, 2015	Sheet 17 of 37

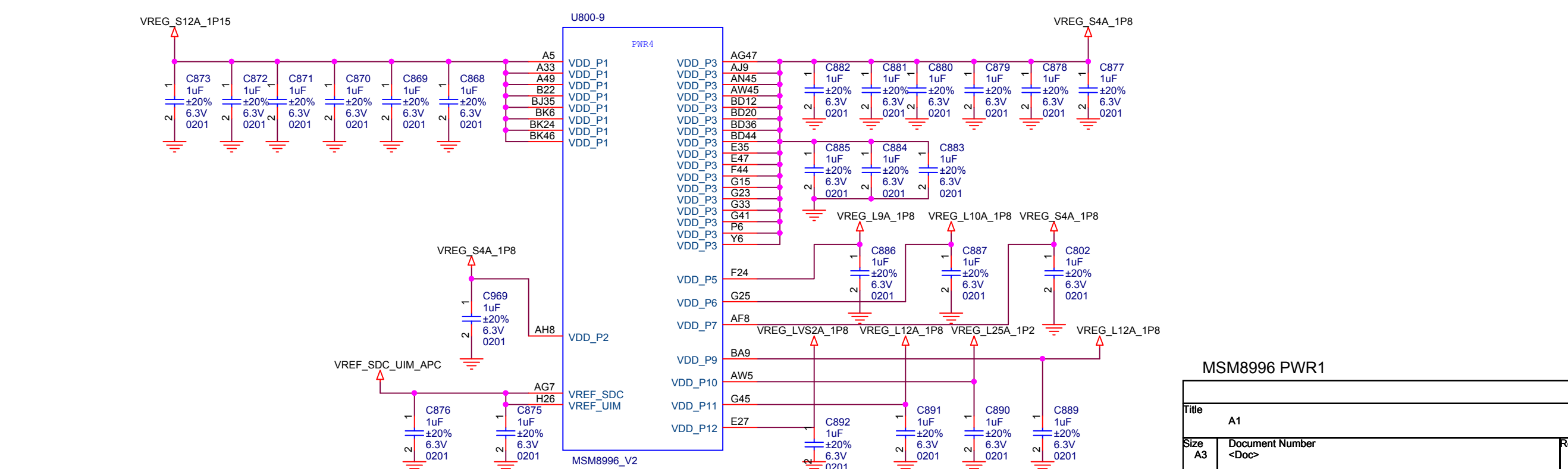
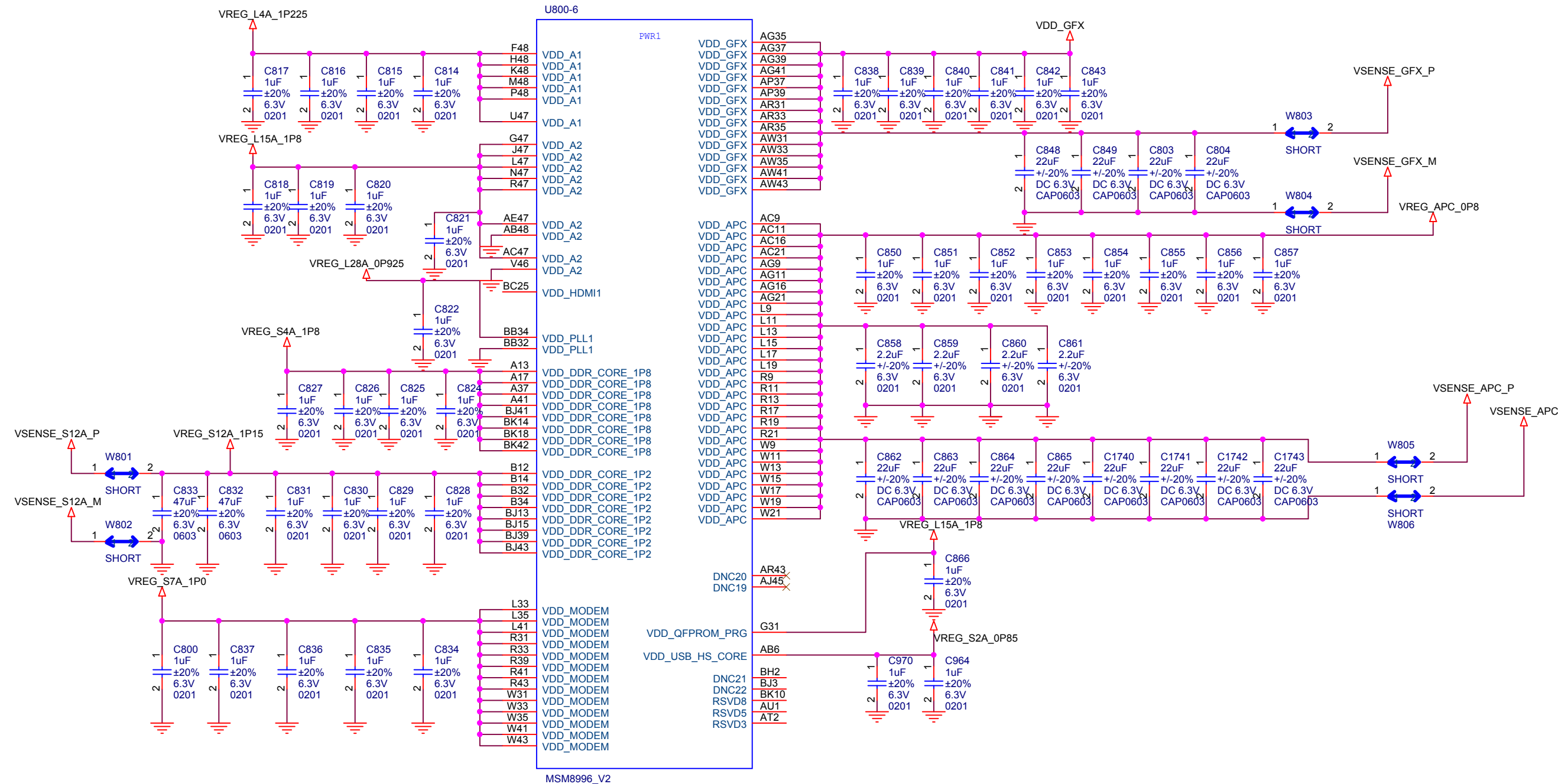

MSM8996 PWR1		
Title	A1	
Size	Document Number	Rev
A3	<Doc>	P0
Date:	Wednesday, December 09, 2015	Sheet 18 of 37

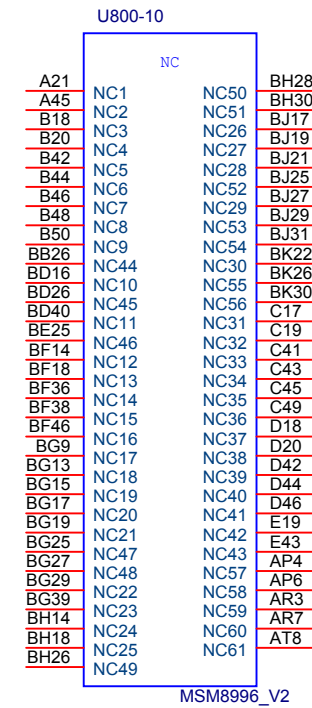
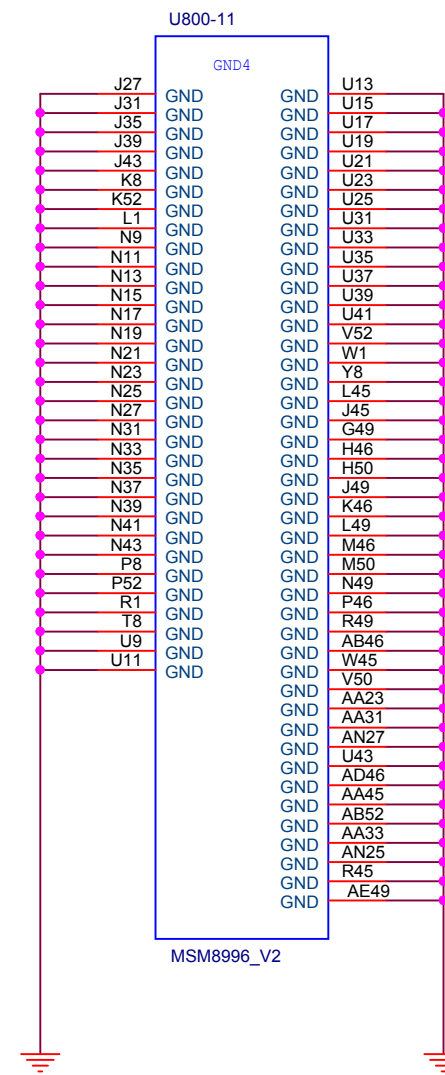
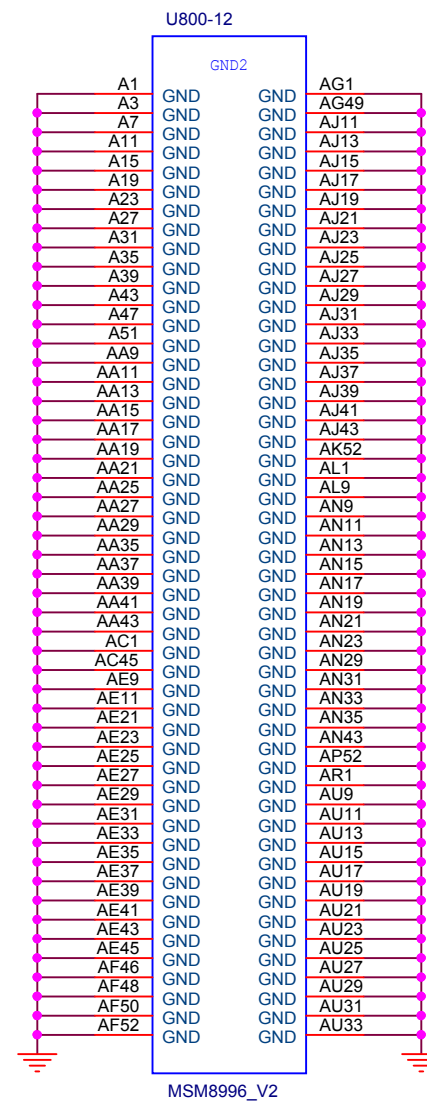
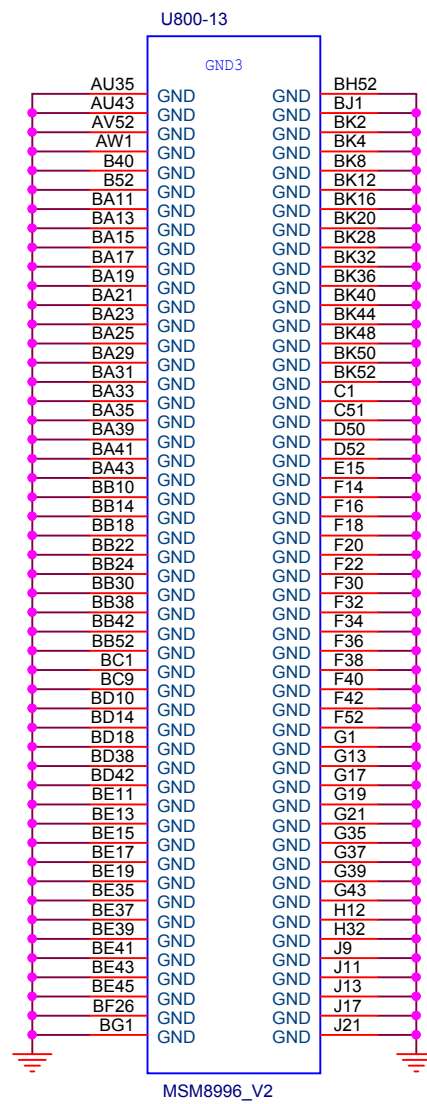

MSM8996 GND

Title		
A1		
Size	Document Number	Rev
A3	<Doc>	P0
Date:	Wednesday, December 09, 2015	Sheet 20 of 37

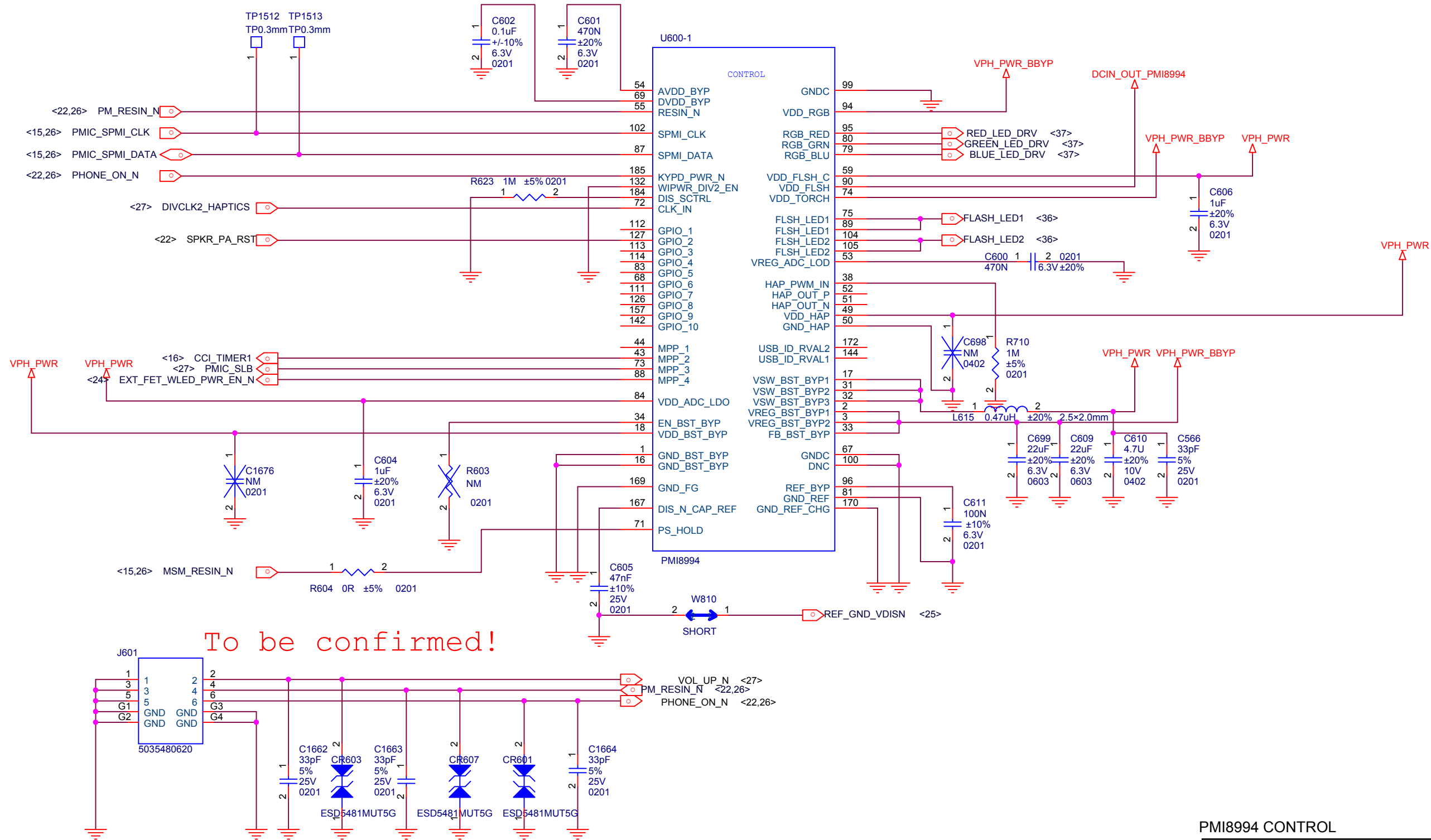

PM18994 CONTROL		
Title A1		
Size A3	Document Number <Doc>	Rev P0
Date:	Wednesday, December 09, 2015	Sheet 22 of 37

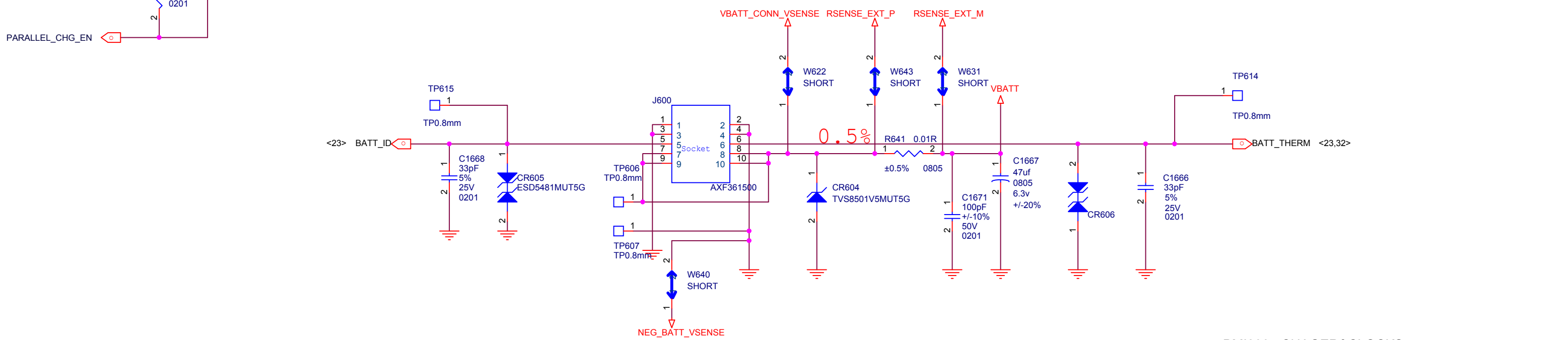
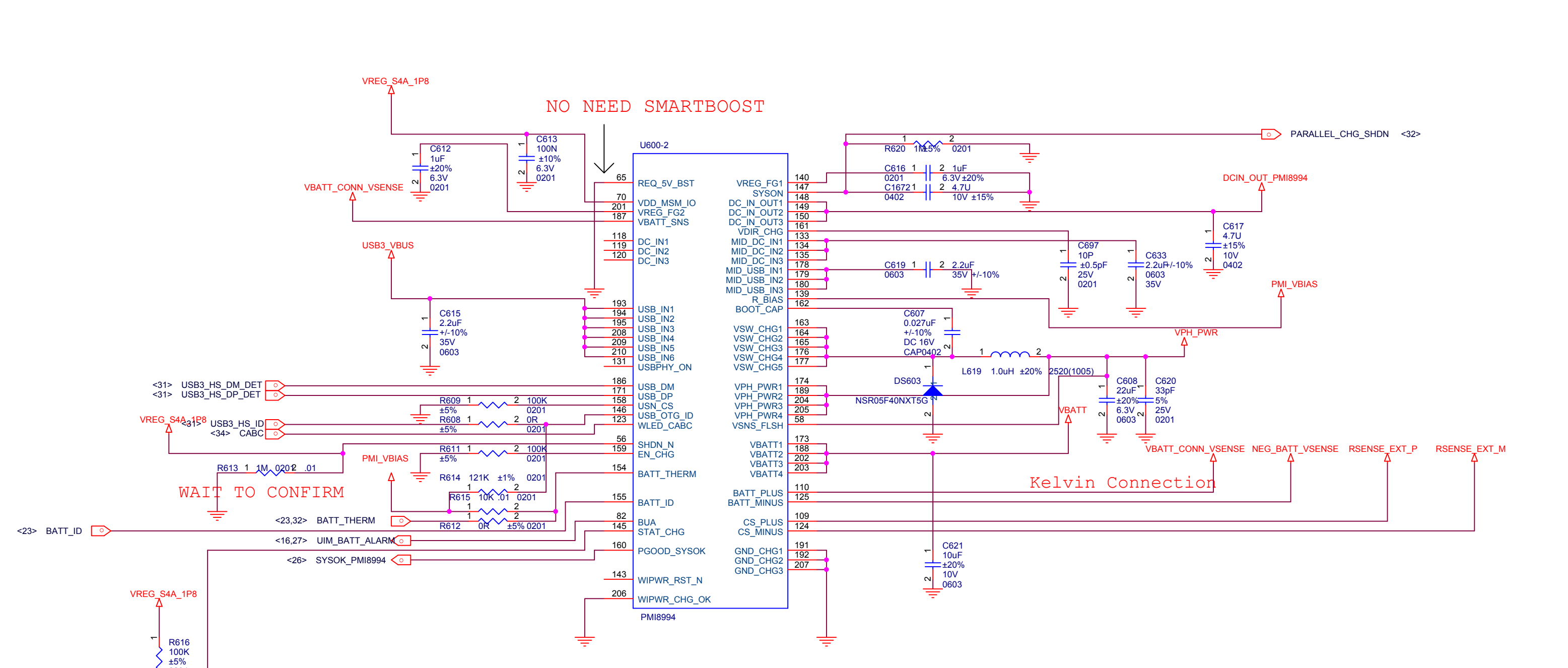

PMI8994 CHAGER&CLOCKS

Title		A1
Size	Document Number	Rev
A3	<Doc>	P0
Date:	Wednesday, December 09, 2015	Sheet 23 of 37

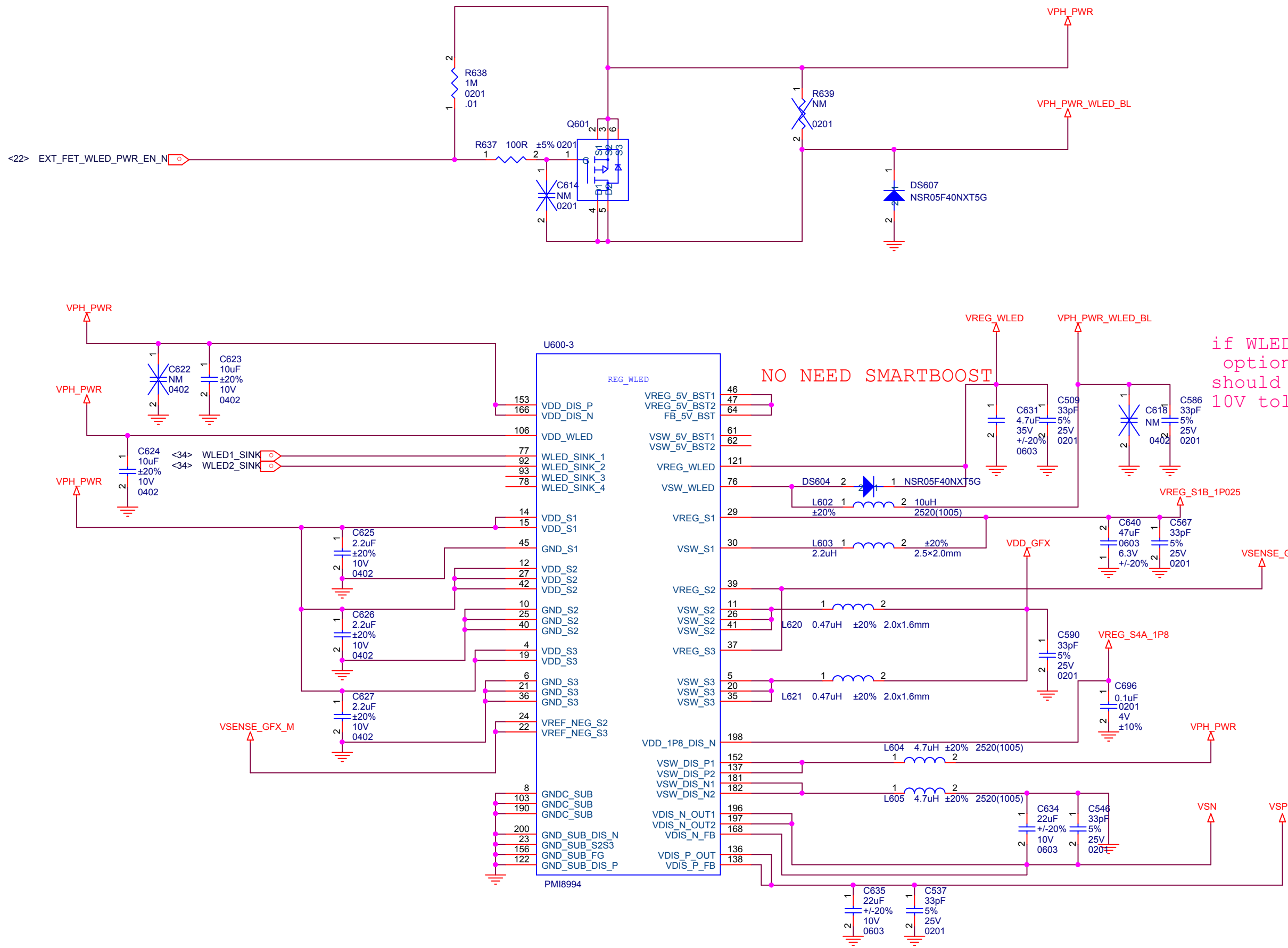

NO NEED SMARTBOOST

if WLED short circuit protection option is not used, C1670 should be changed to 10uF, 10V tolerance capacitor

PMI8994 REG WLED

Title		
A1		
Size	Document Number	Rev
A3	<Doc>	P0
Date:	Wednesday, December 09, 2015	Sheet 24 of 37

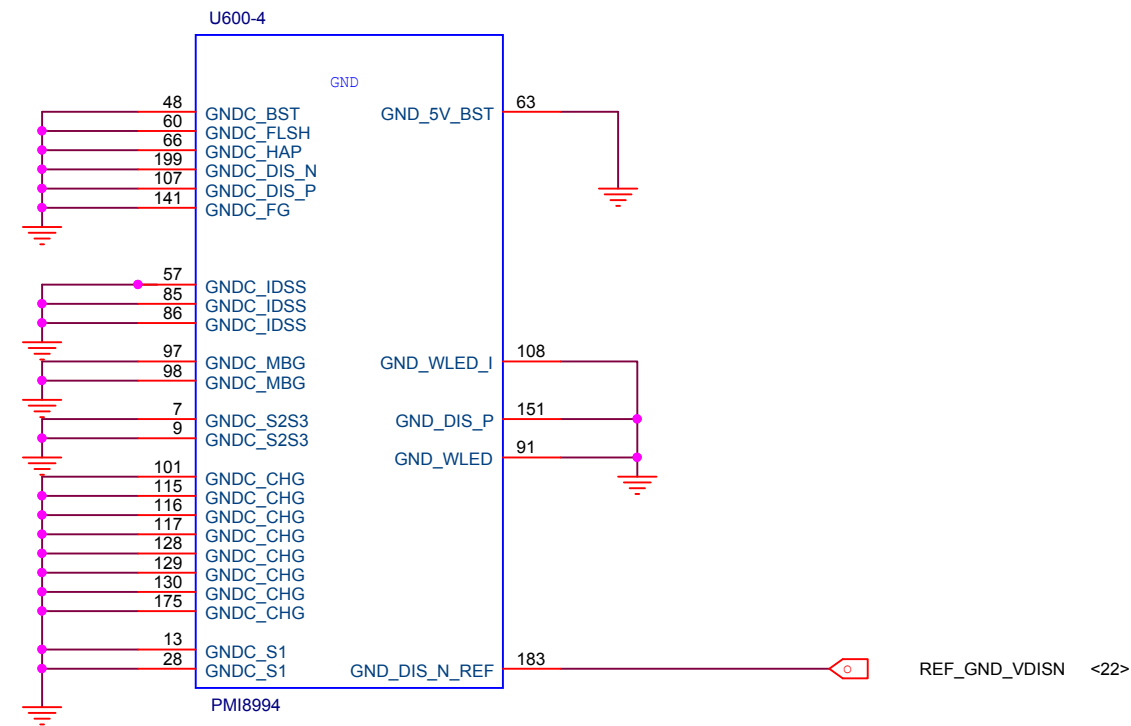

CAD NOTE: Connect to pin183 then GND with single via

PMI8994 GND

Title		
A1		
Size	Document Number	Rev
A3	<Doc>	P0
Date:	Wednesday, December 09, 2015	Sheet 25 of 37

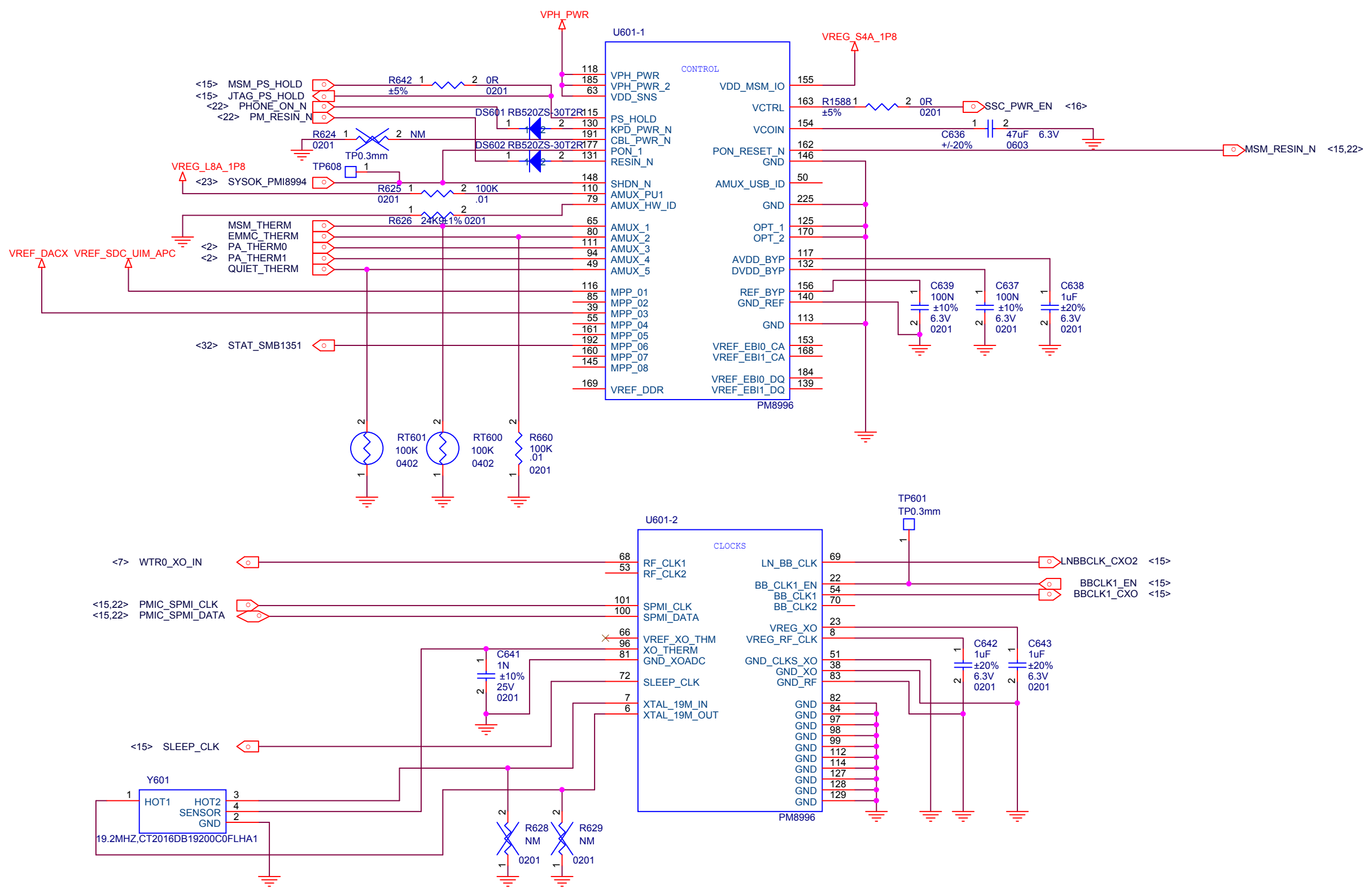

PM8996 CONTROL

Title		
A1		
Size	Document Number	Rev
A3	<Doc>	P0
Date:	Wednesday, December 09, 2015	Sheet 26 of 37

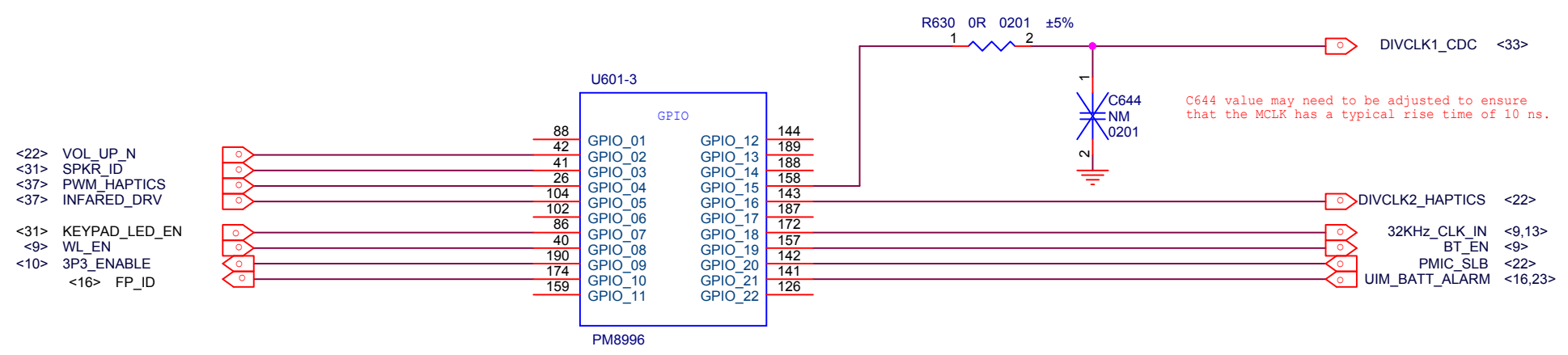

PM8996 GPIO

Title		
A1		
Size	Document Number	Rev
A3	<Doc>	P0
Date:	Wednesday, December 09, 2015	Sheet 27 of 37

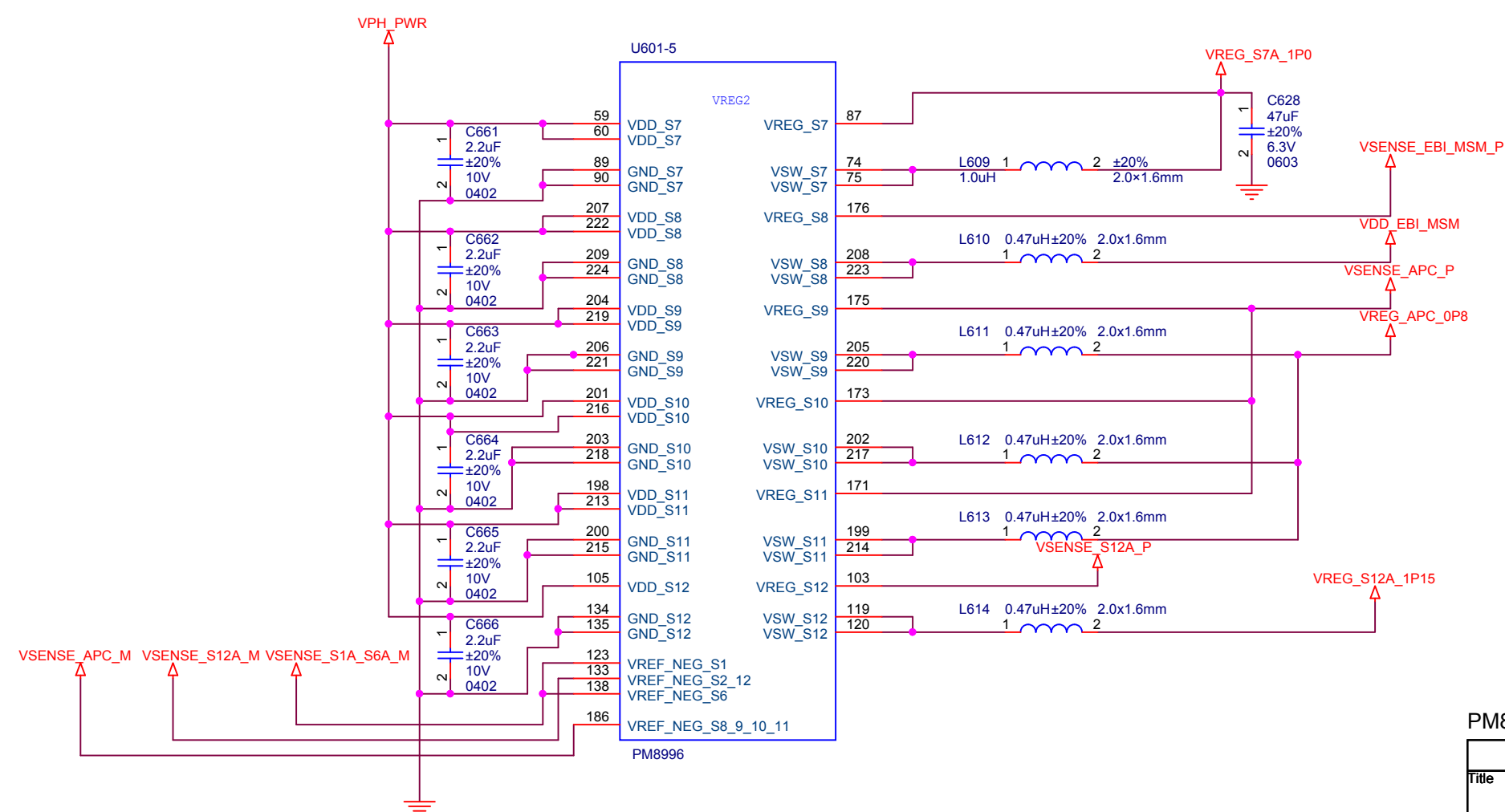
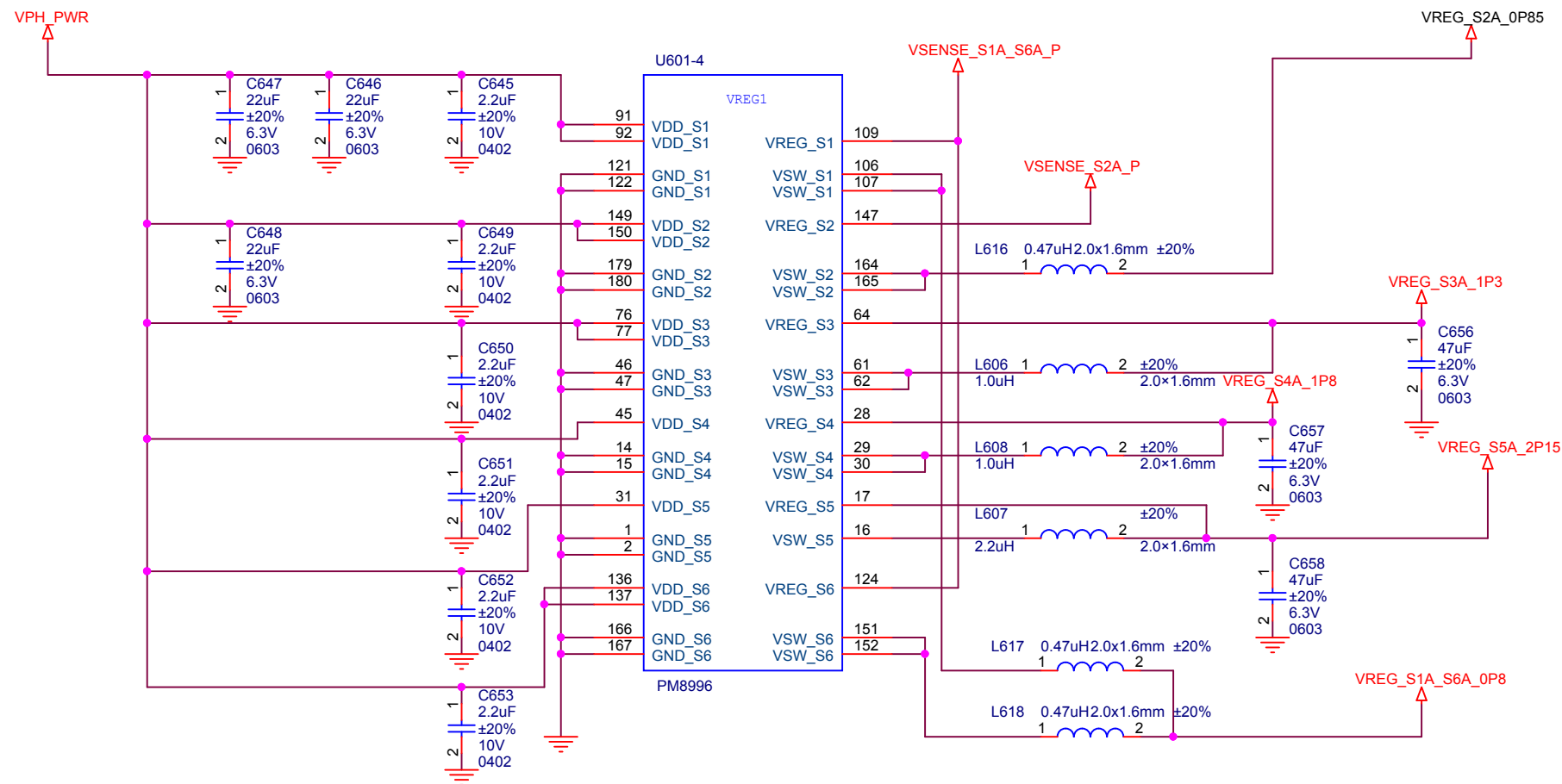

PM8996 VREG

Title		
A1		
Size	Document Number	Rev
A3	<Doc>	P0
Date:	Wednesday, December 09, 2015	Sheet 28 of 37

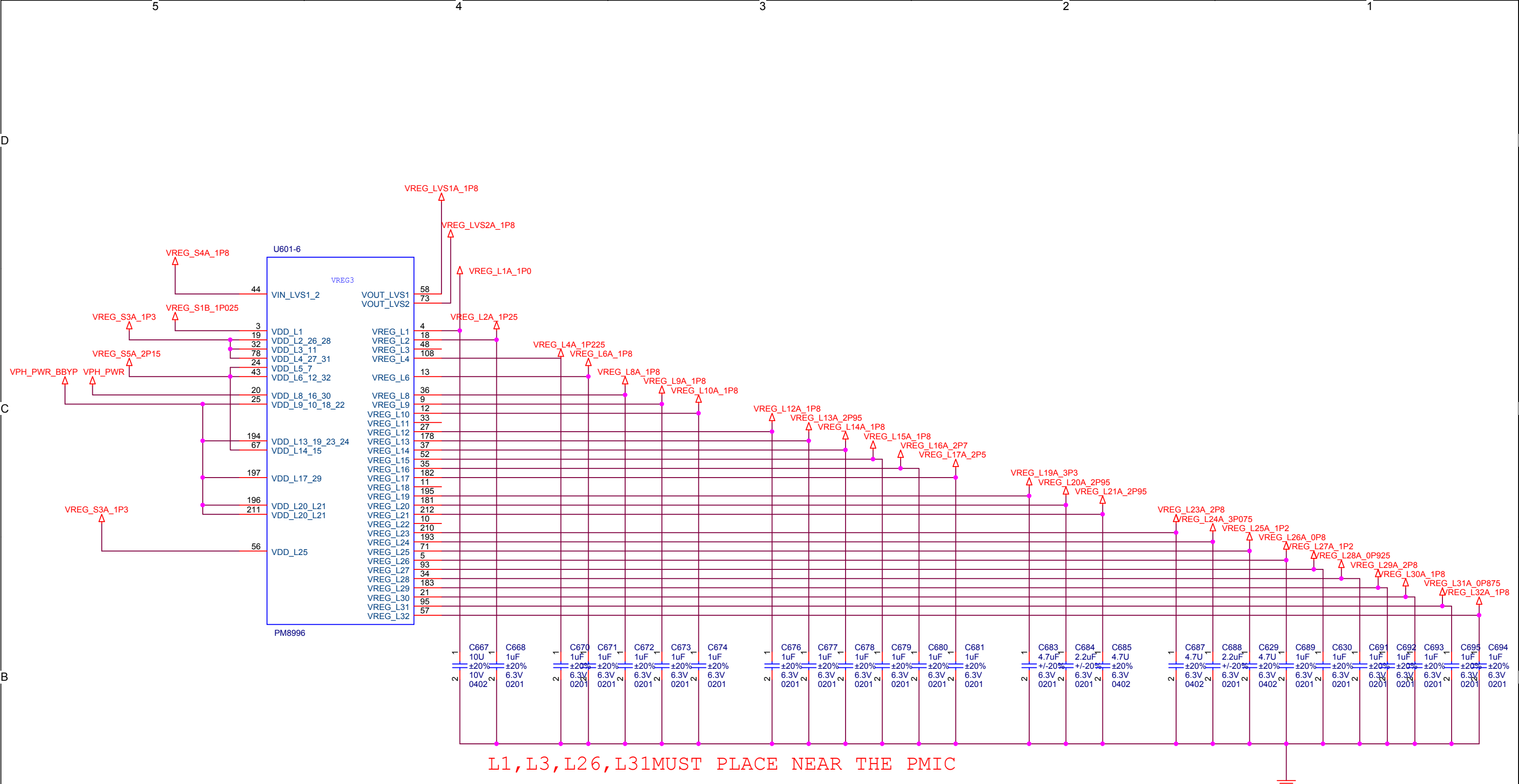

PM8996 LDO

Title		A1
Size	Document Number	Rev
A3	<Doc>	P0
Date:	Wednesday, December 09, 2015	Sheet 29 of 37

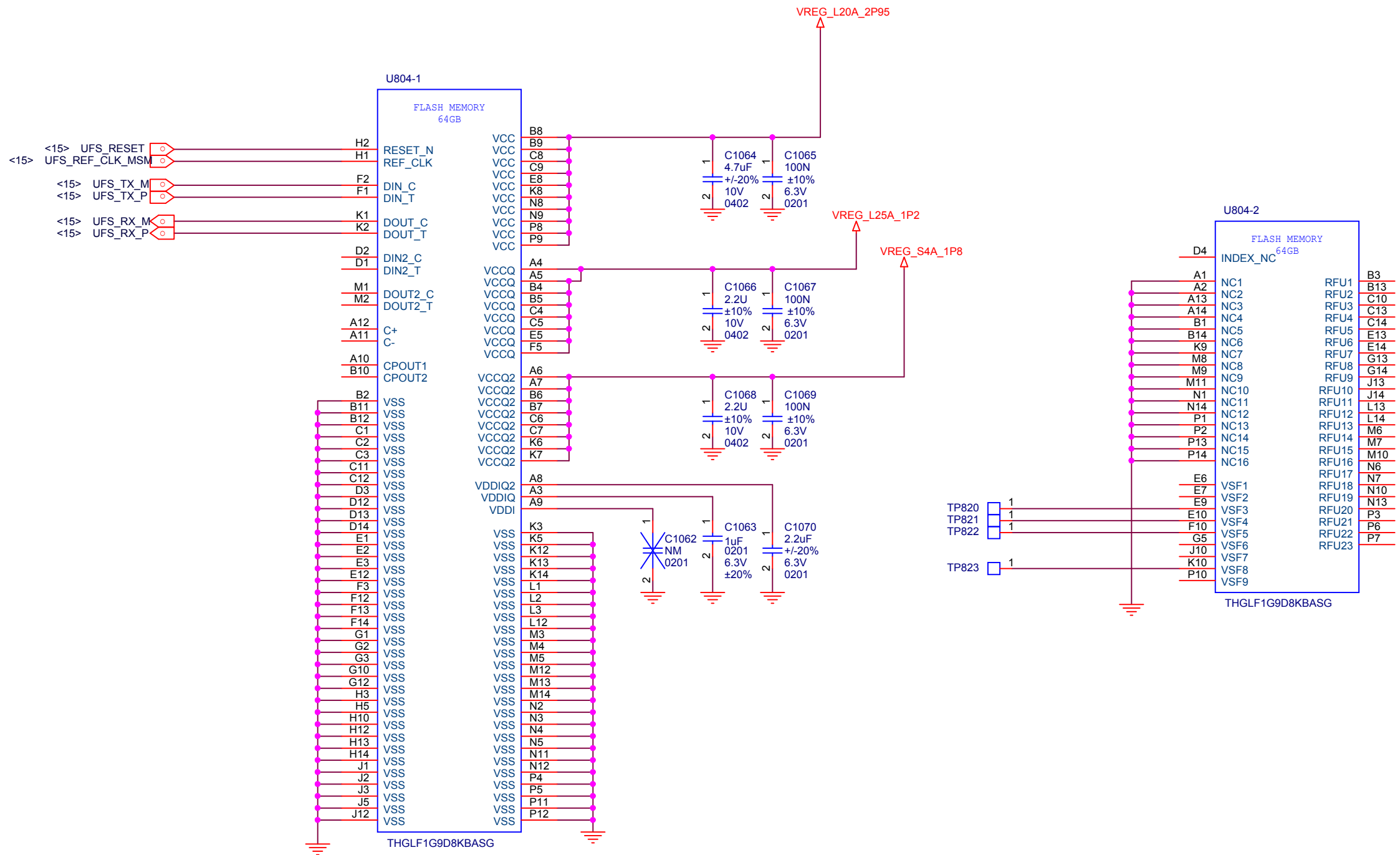

MEMORY UFS

Title			A1
Size	Document Number	Rev	
A3	<Doc>	P0	
Date:	Wednesday, December 09, 2015	Sheet	30 of 37

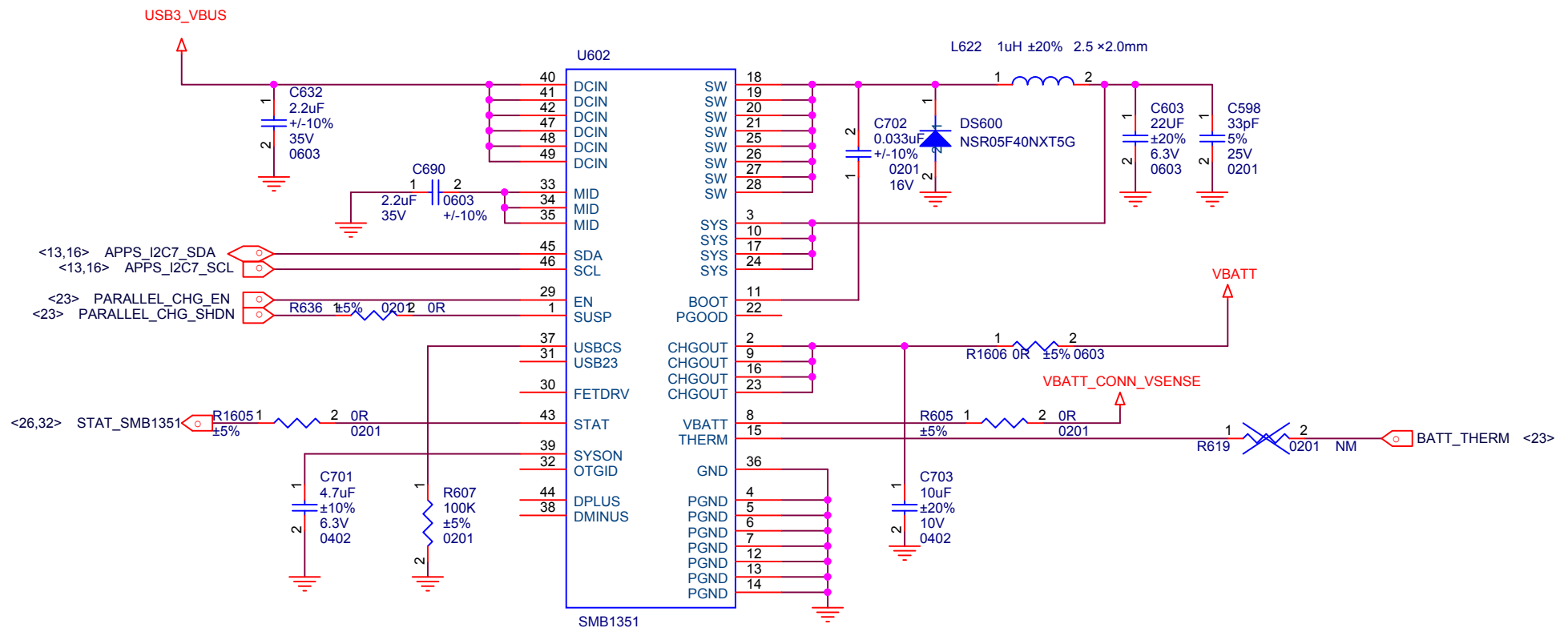

SMB1357 CHARGER

Title		A1
Size	Document Number	Rev
A3	<Doc>	P0
Date:	Wednesday, December 09, 2015	Sheet 32 of 37

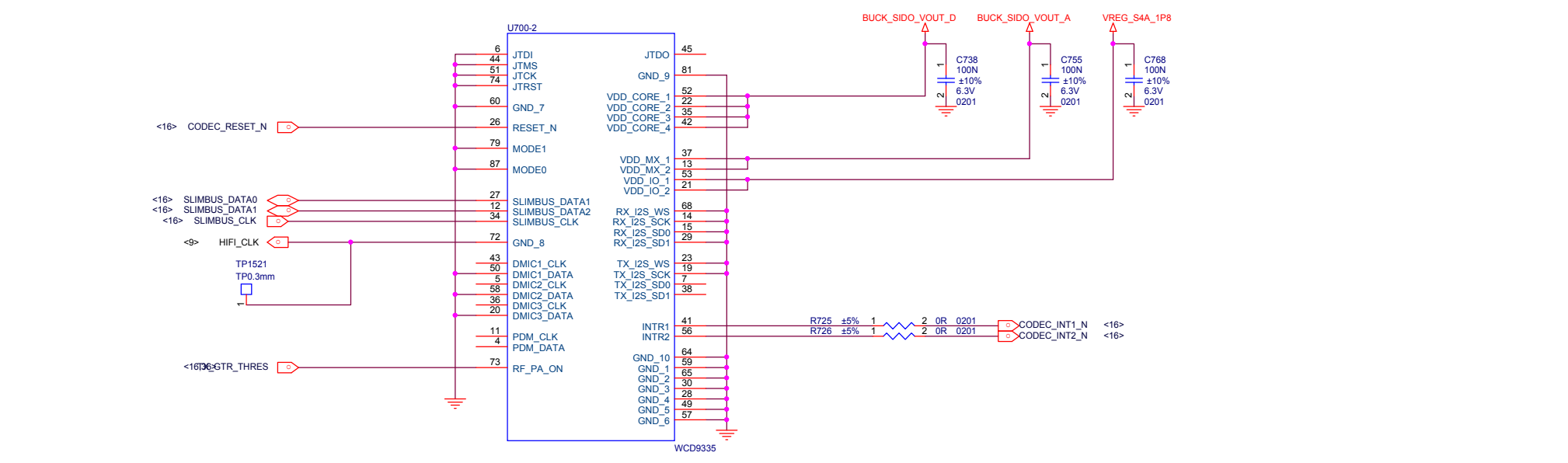
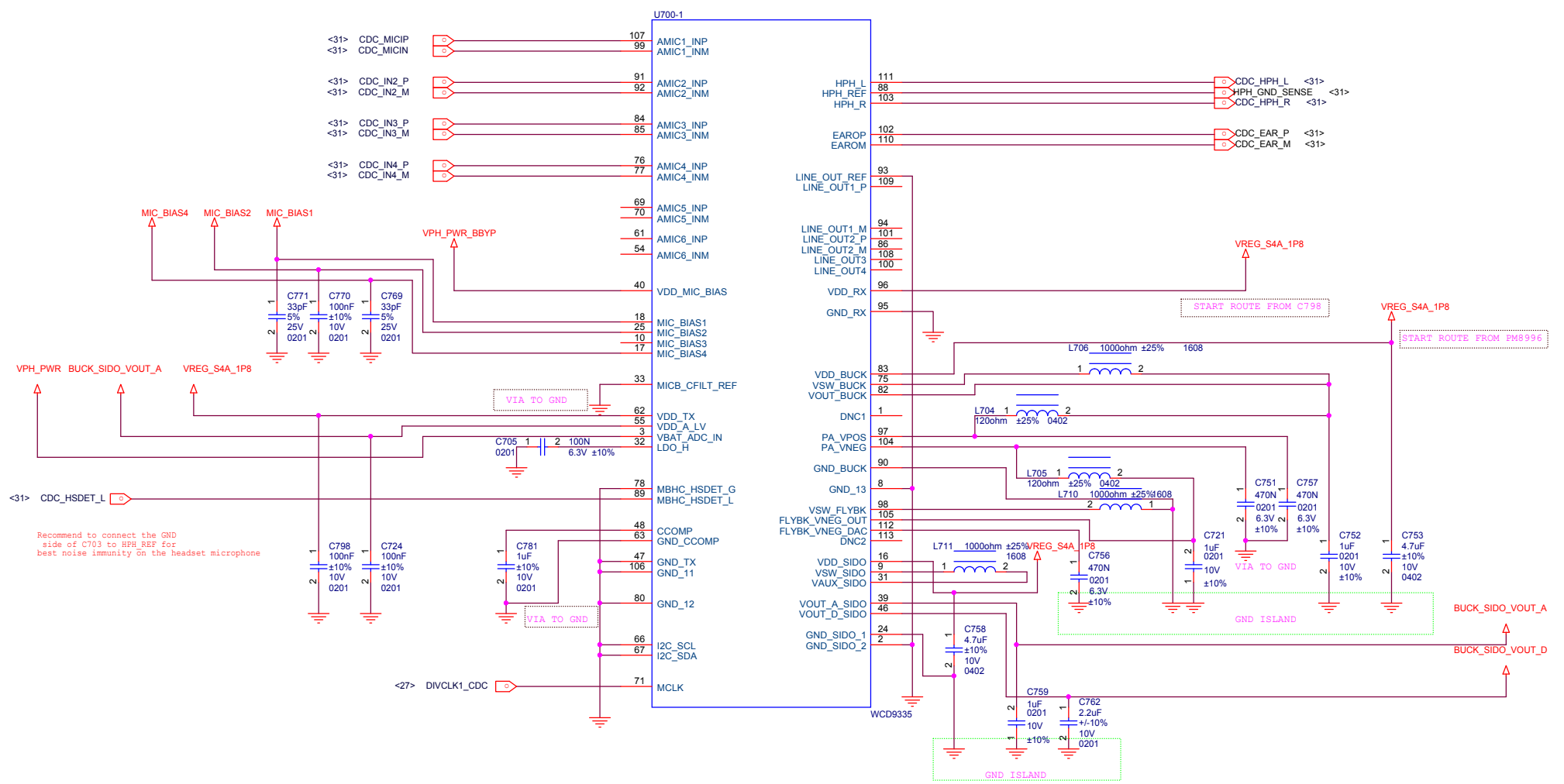

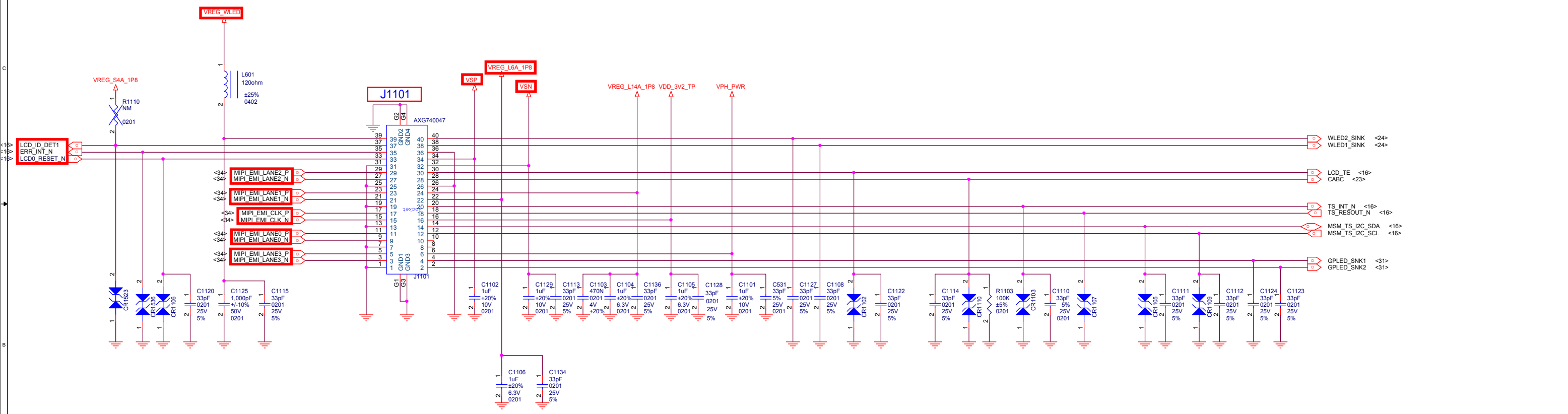
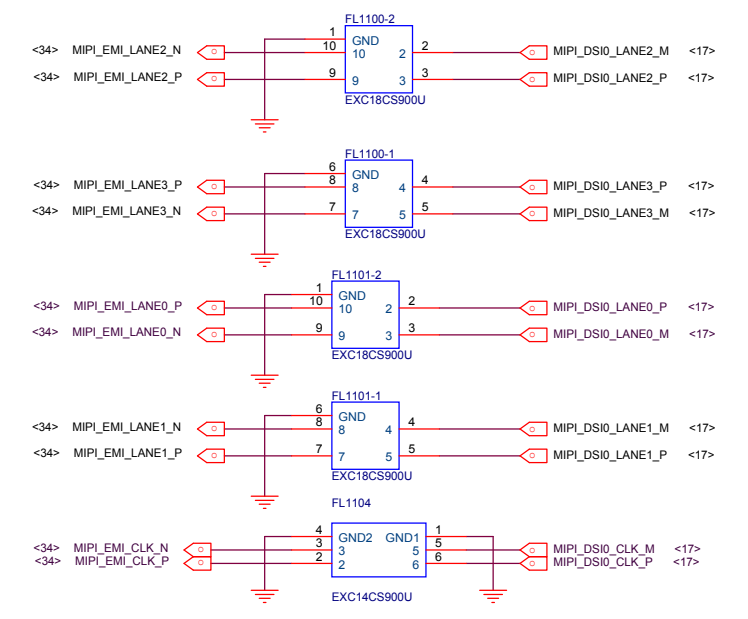
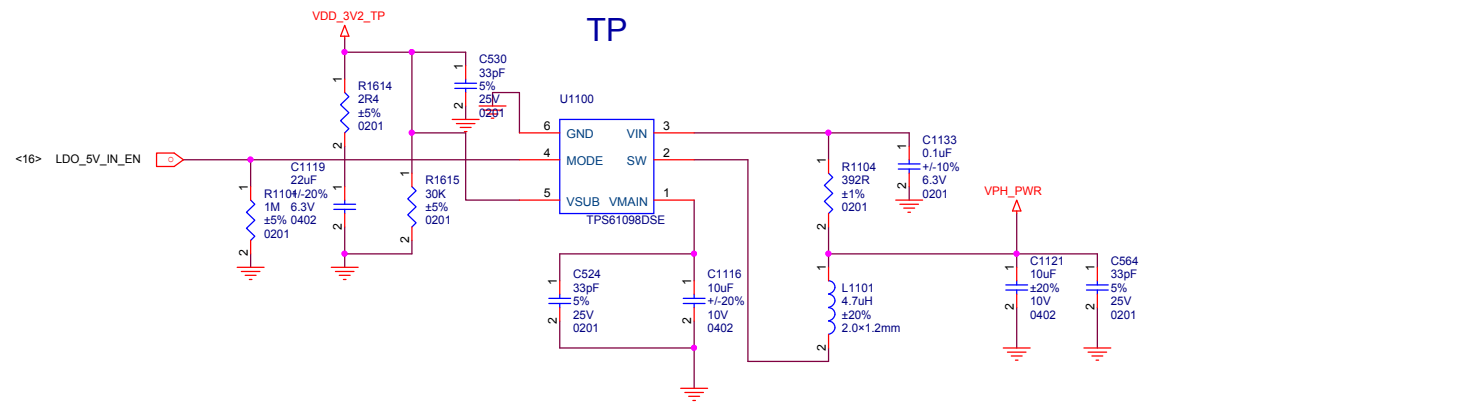

LCD

XIAO MI		
Title	A1	
Size	Document Number	Rev
A2	LCD	P0
Date:	Wednesday, December 09, 2015	Sheet 34 of 37

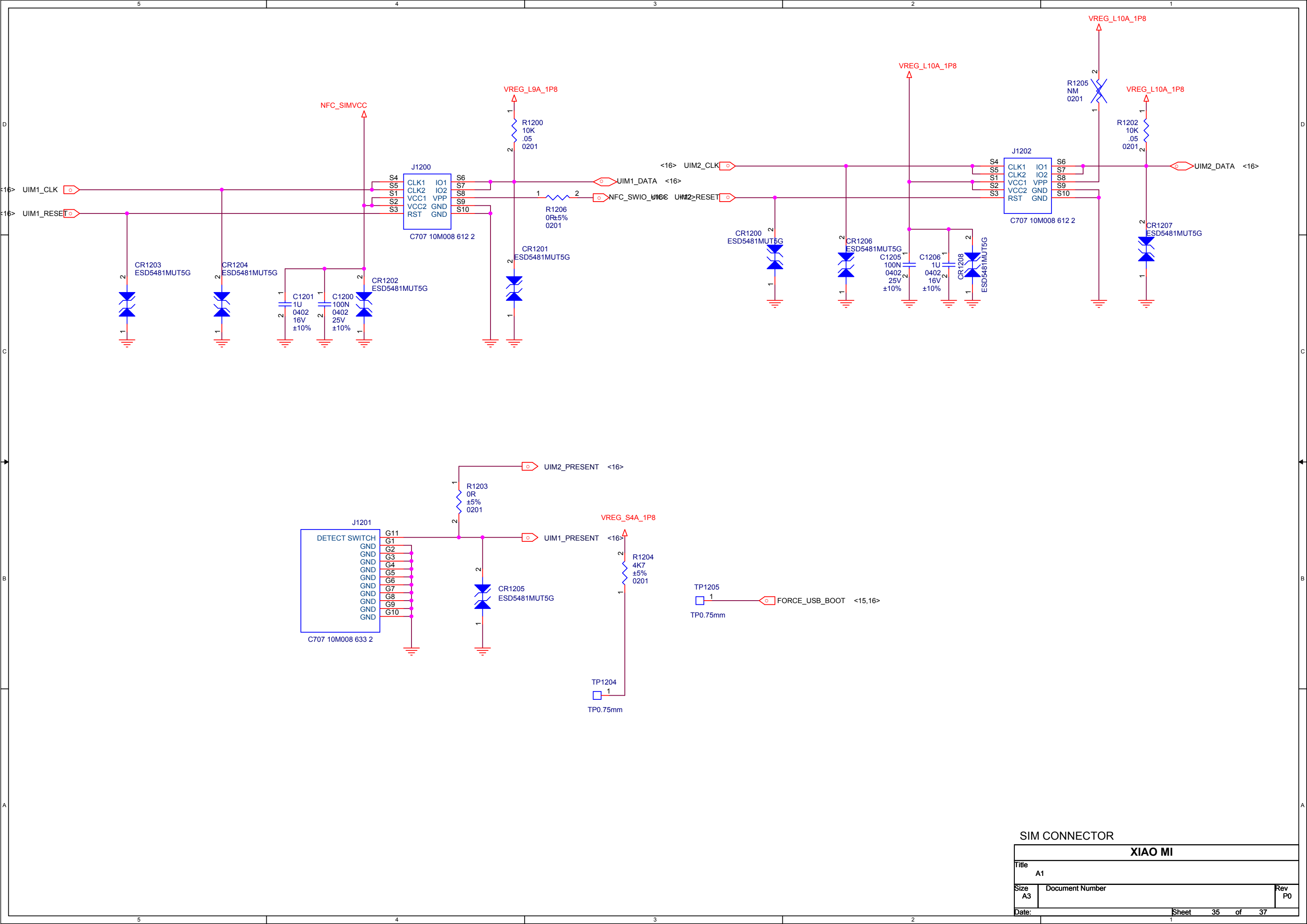

SIM CONNECTOR		
XIAO MI		
Title A1		
Size A3	Document Number	Rev P0
Date:	Sheet 35 of 37	

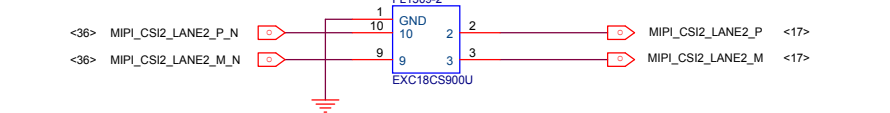
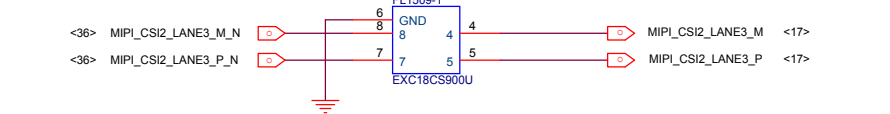
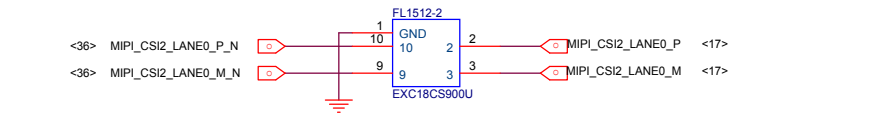
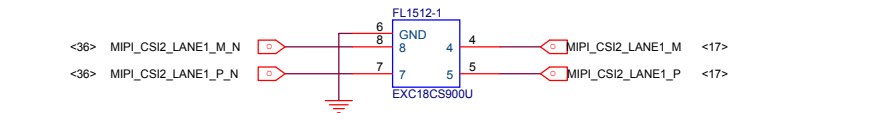
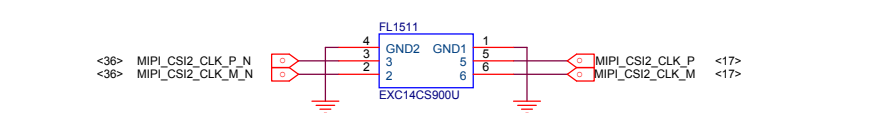
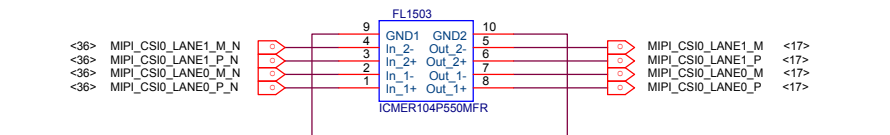
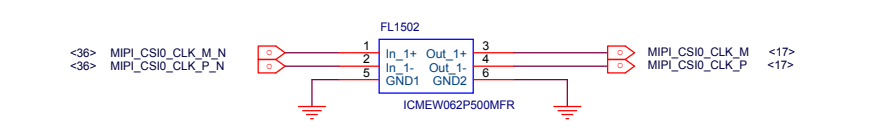
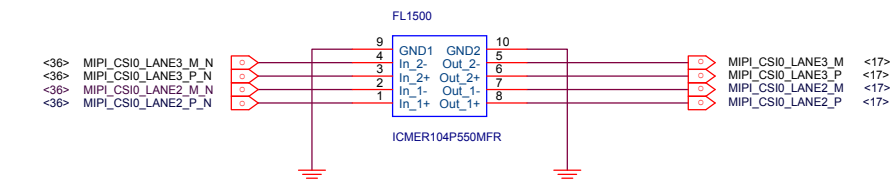
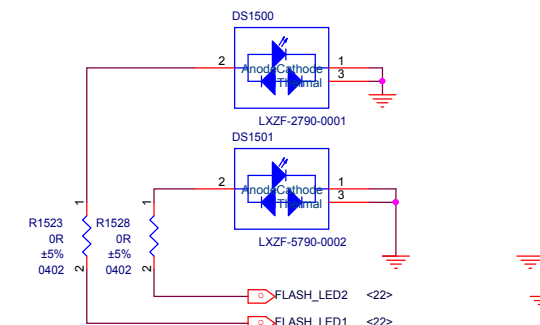
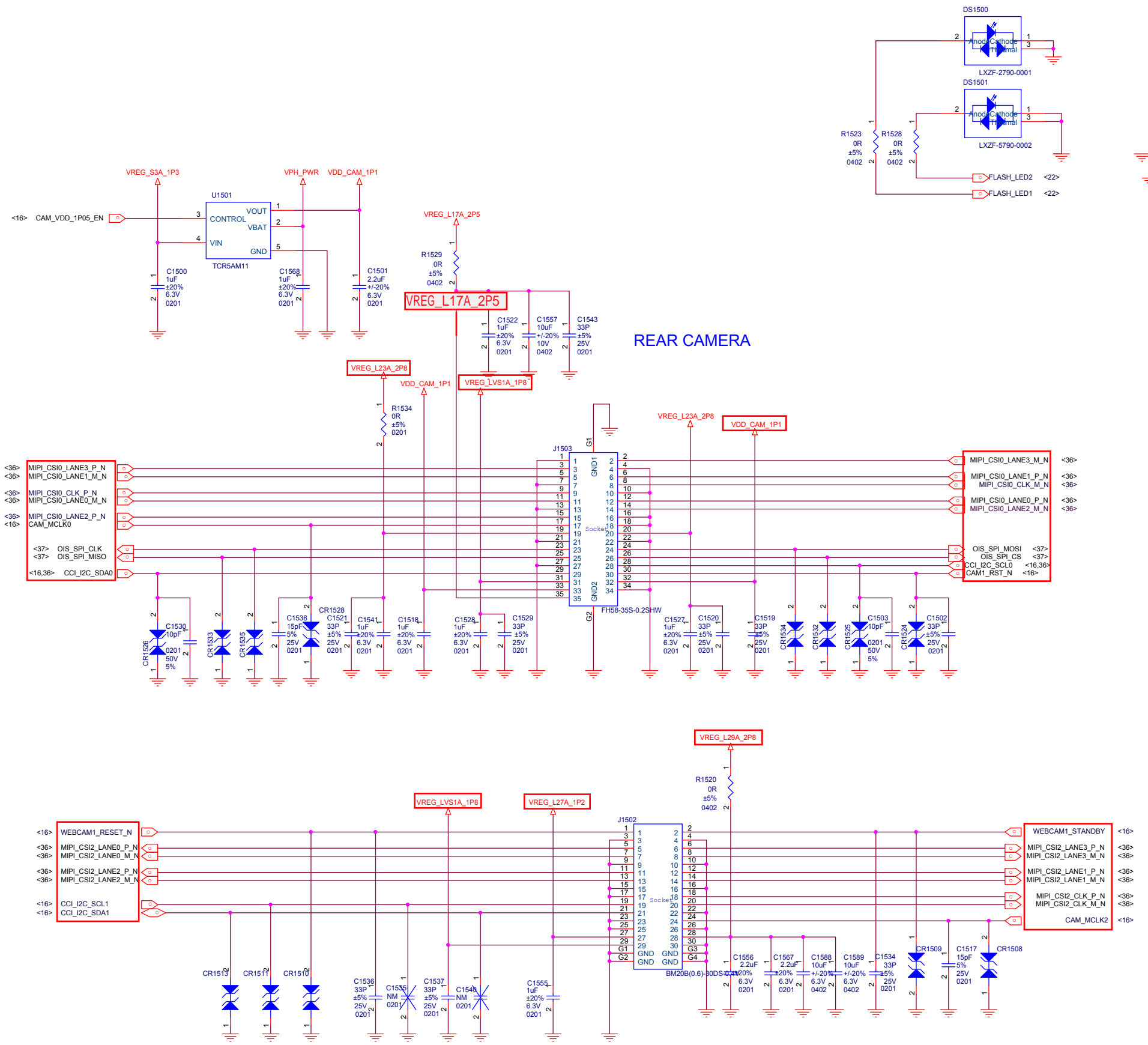

FRONT CAMERA

CAMERA		
XIAO MI		
Title	A1	
Size	Document Number	Rev P0
Date:	Sheet 36	of 37

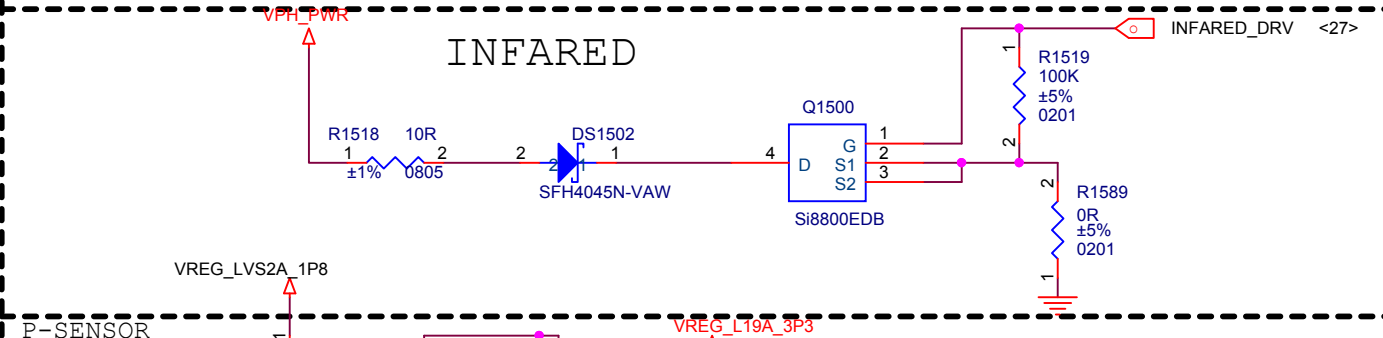
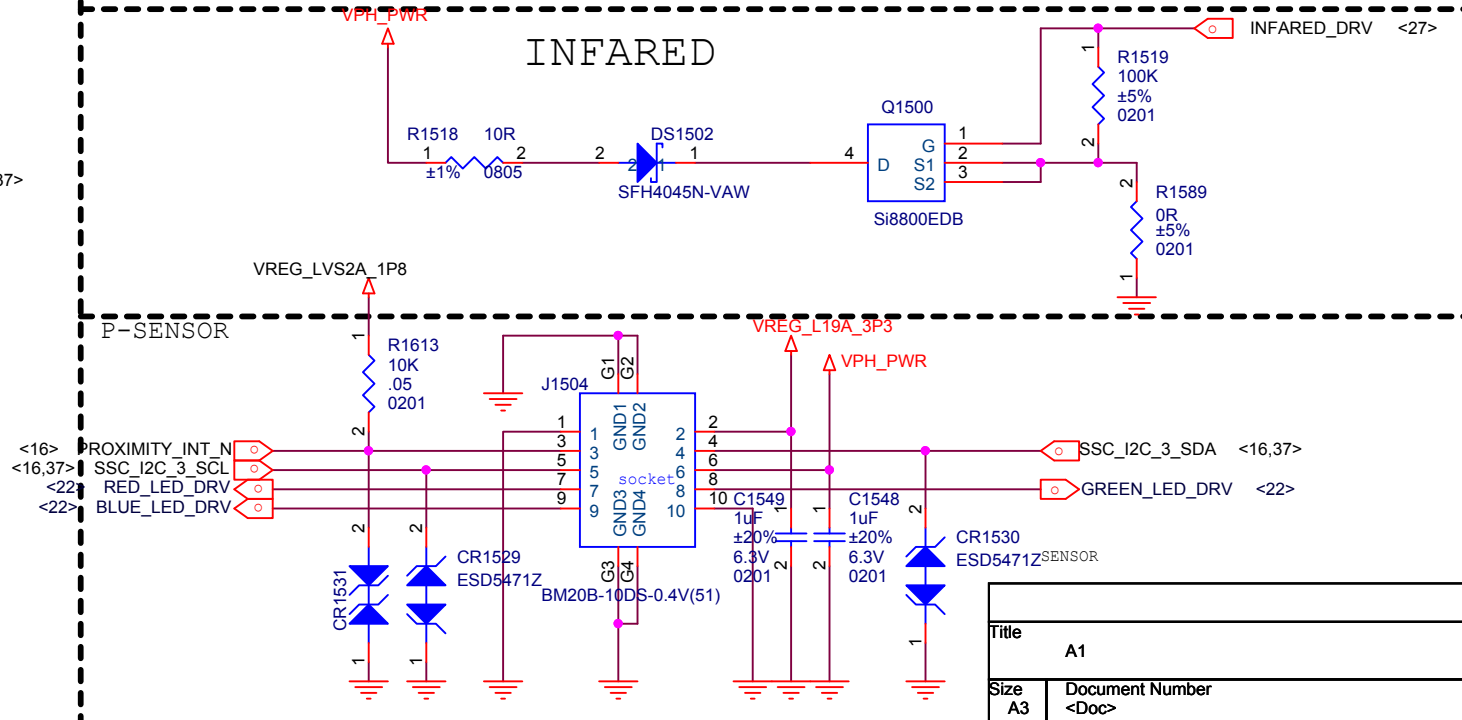
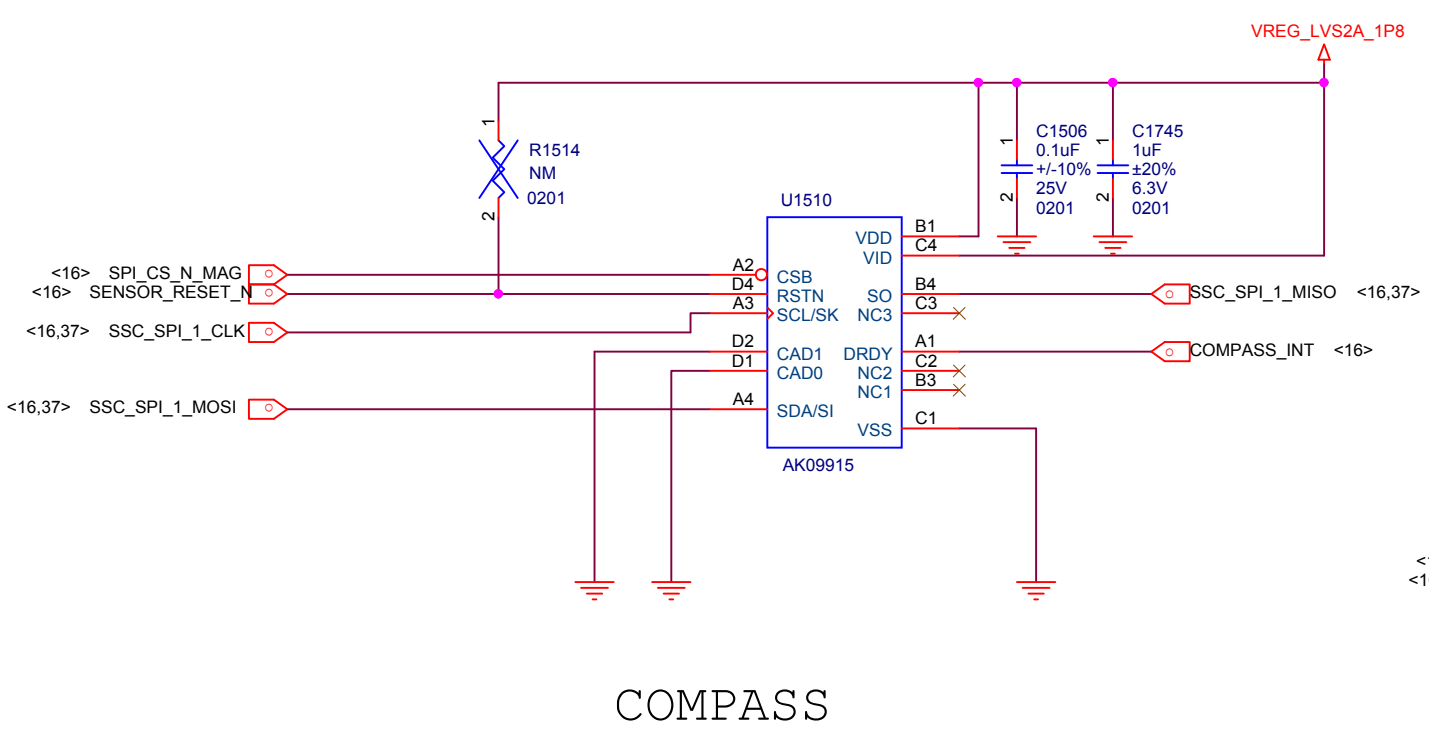
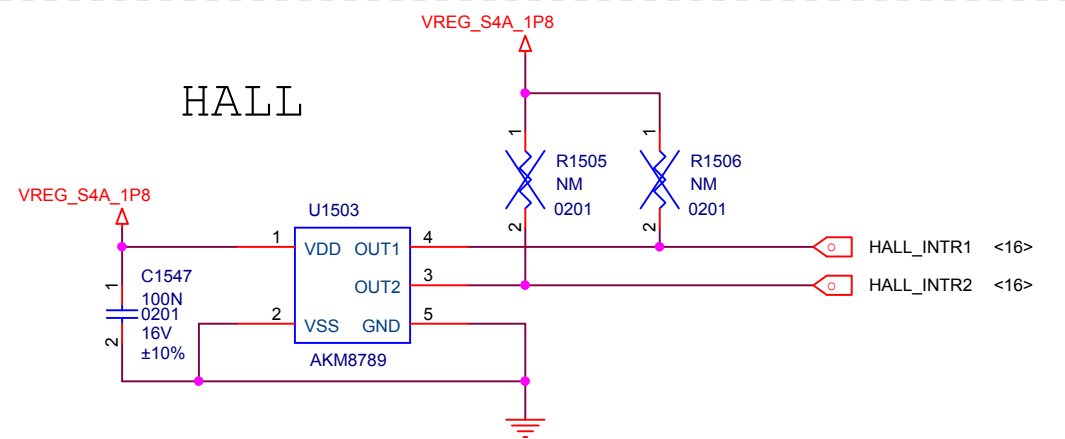
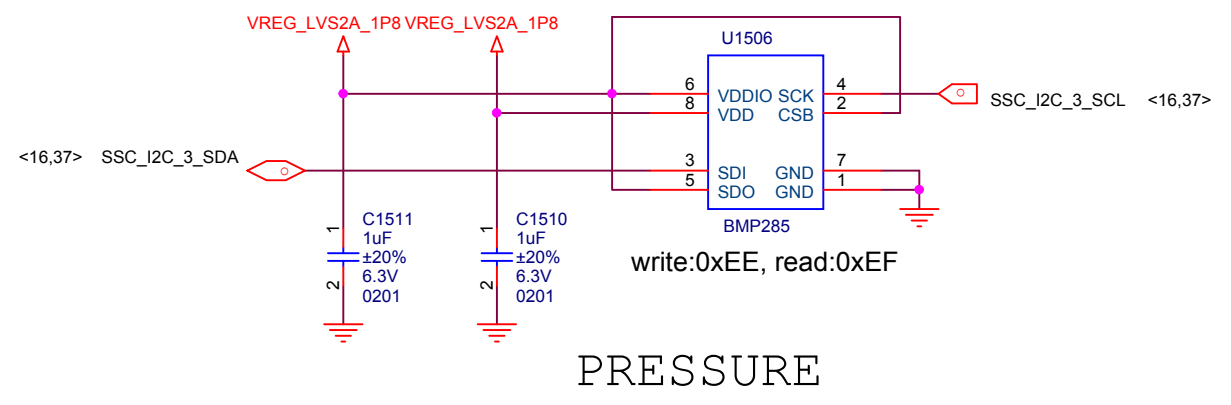
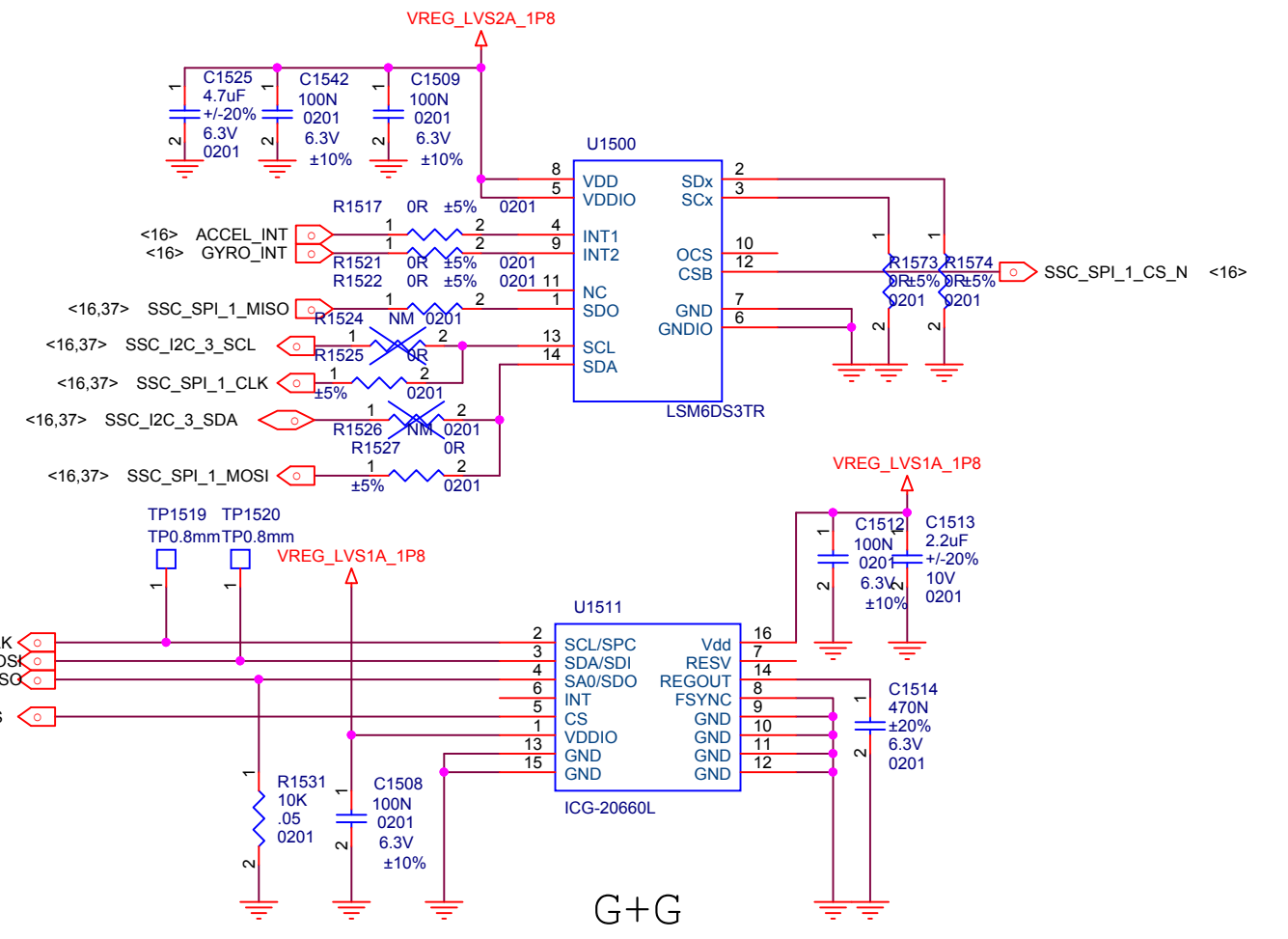
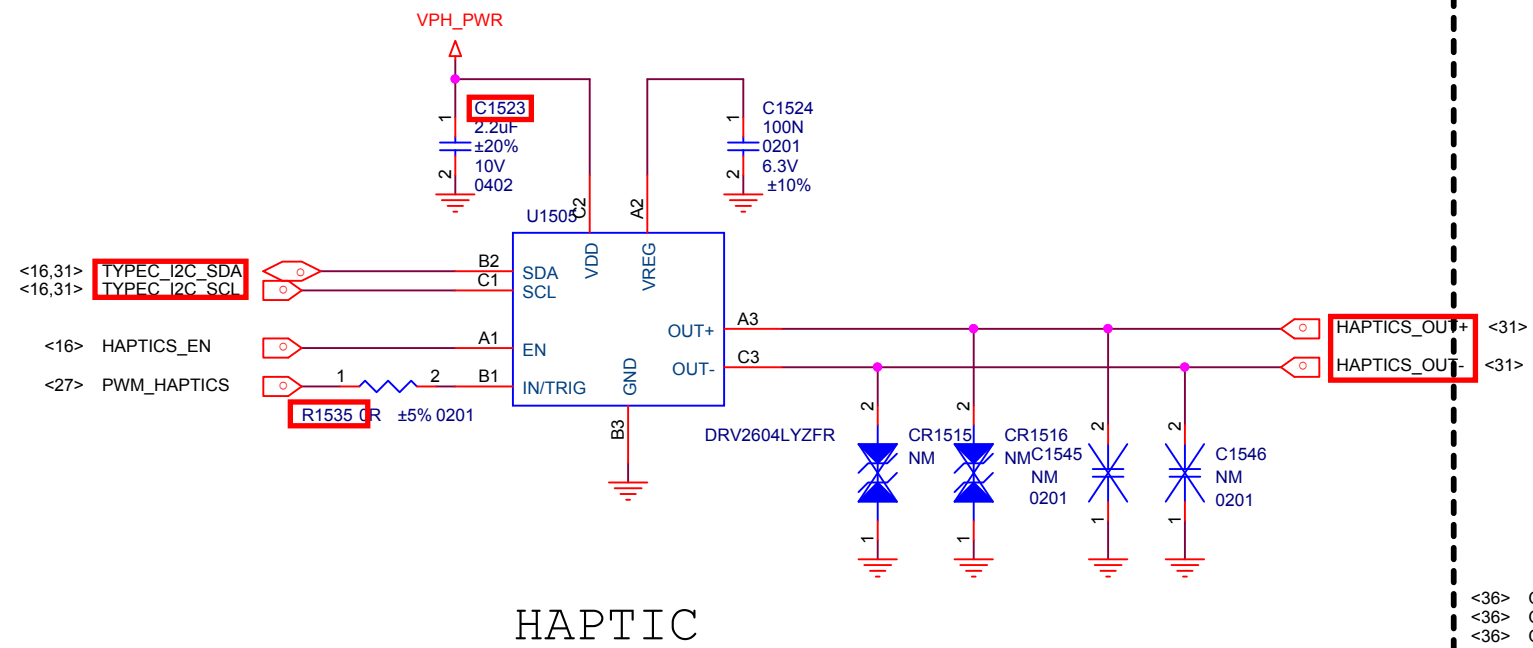

Title		
A1		
Size	Document Number	Rev
A3	<Doc>	P0
Date:	Sheet 37 of 37	