

Title		
B3		
Size	Document Number	Rev
A3	<Doc>	P0
Date:	Tuesday, March 15, 2016	Sheet 1 of 41

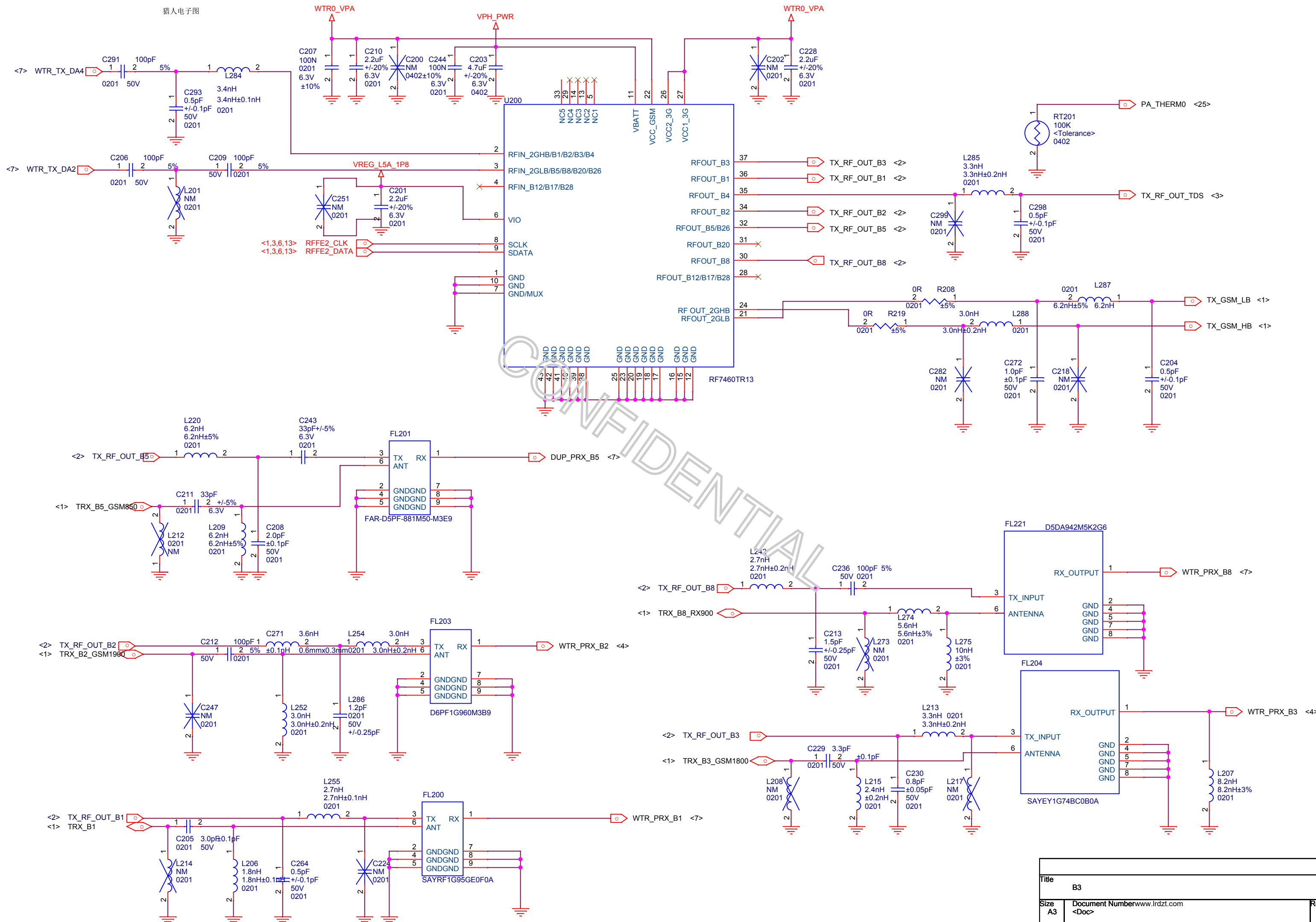

Title		
B3		
Size	Document Number	Rev
A3	www.lrdzt.com	P0
Date:		Sheet
Thursday, February 25, 2016		2 of 41

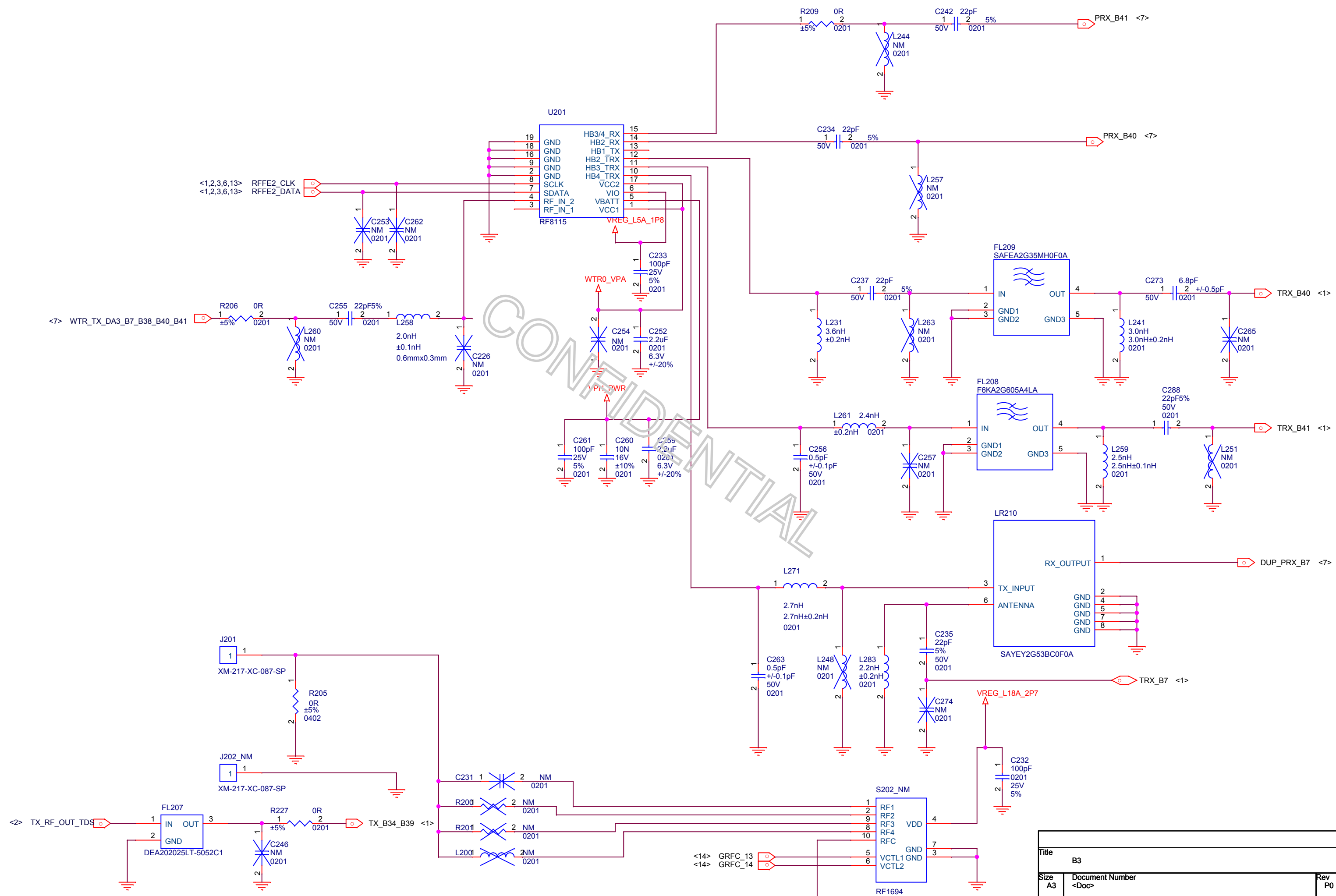

Title		
B3		
Size	Document Number	Rev
A3	<Doc>	P0
Date:	Thursday, February 25, 2016	Sheet 3 of 41

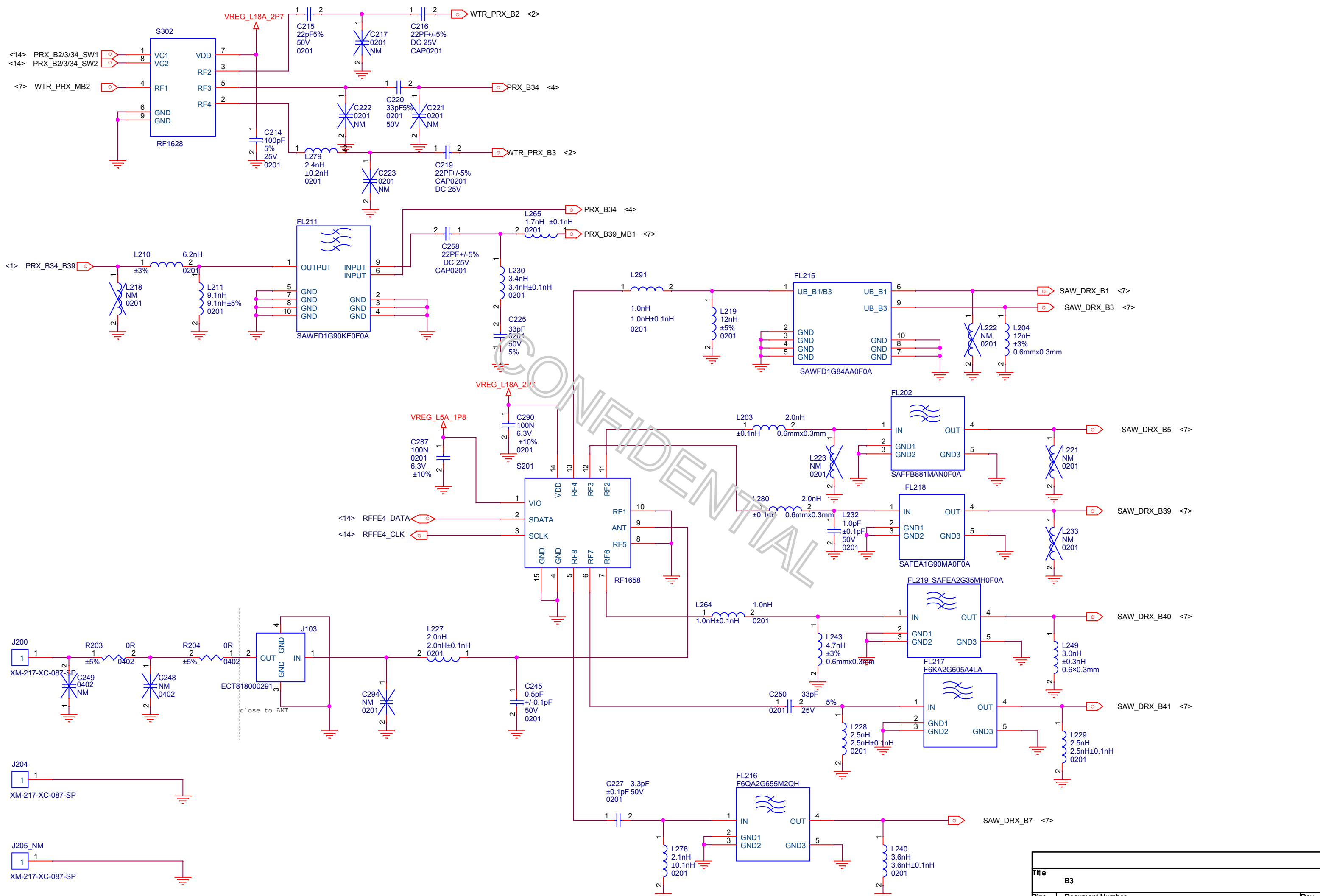

Title		
B3		
Size	Document Number	Rev
A3	<Doc>	P0
Date:	Thursday, February 25, 2016	Sheet 4 of 41

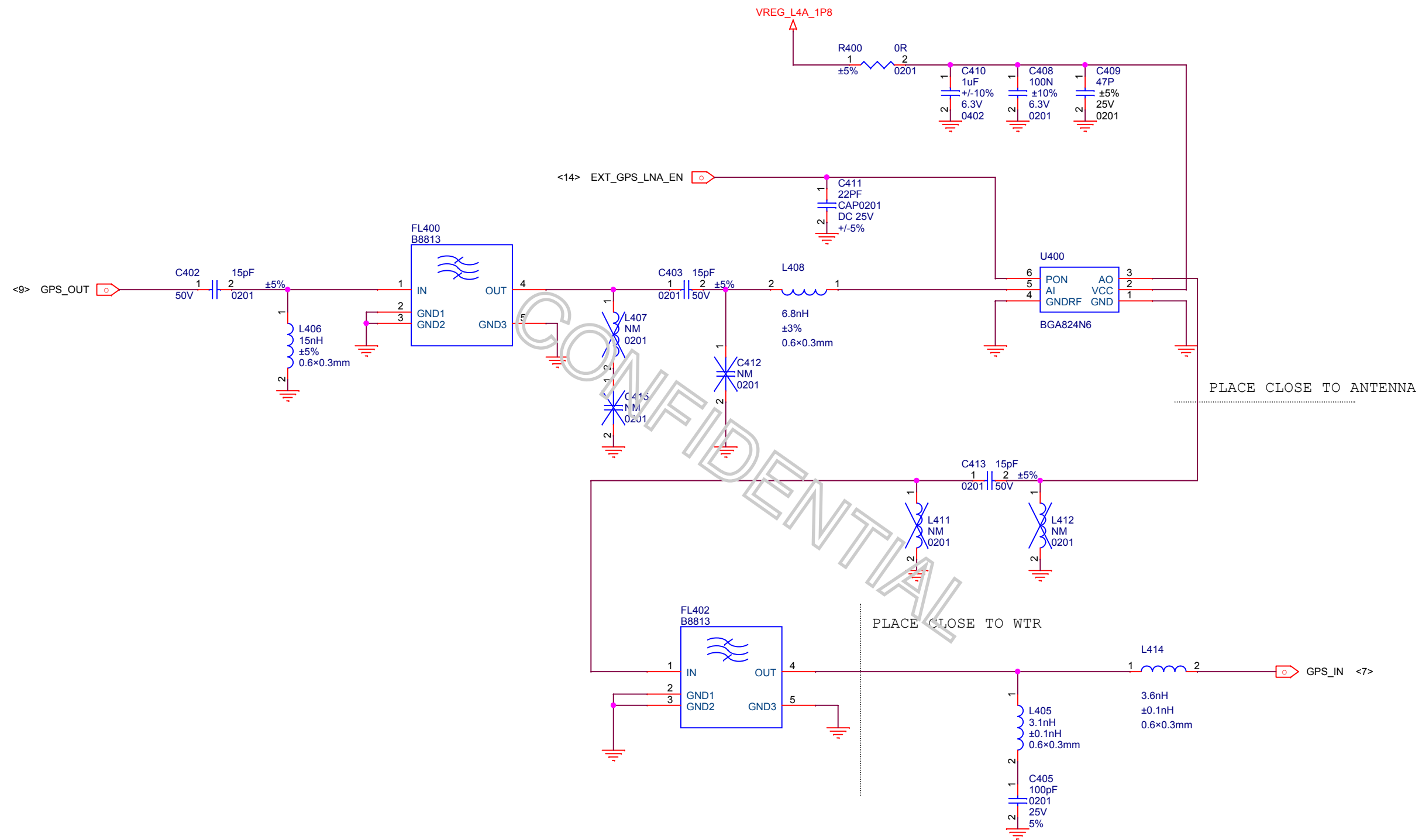

GPS

Title		
B3		
Size	Document Number	Rev
A3	<Doc>	P0
Date:	Tuesday, February 23, 2016	Sheet 5 of 41

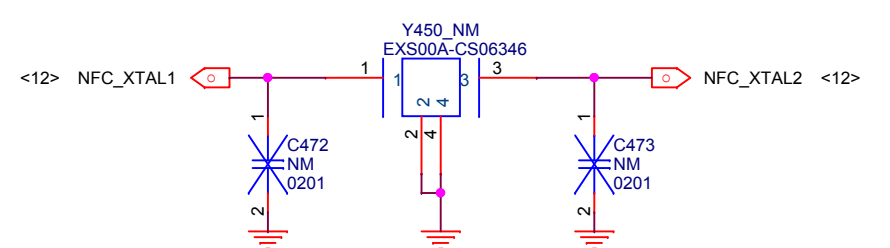
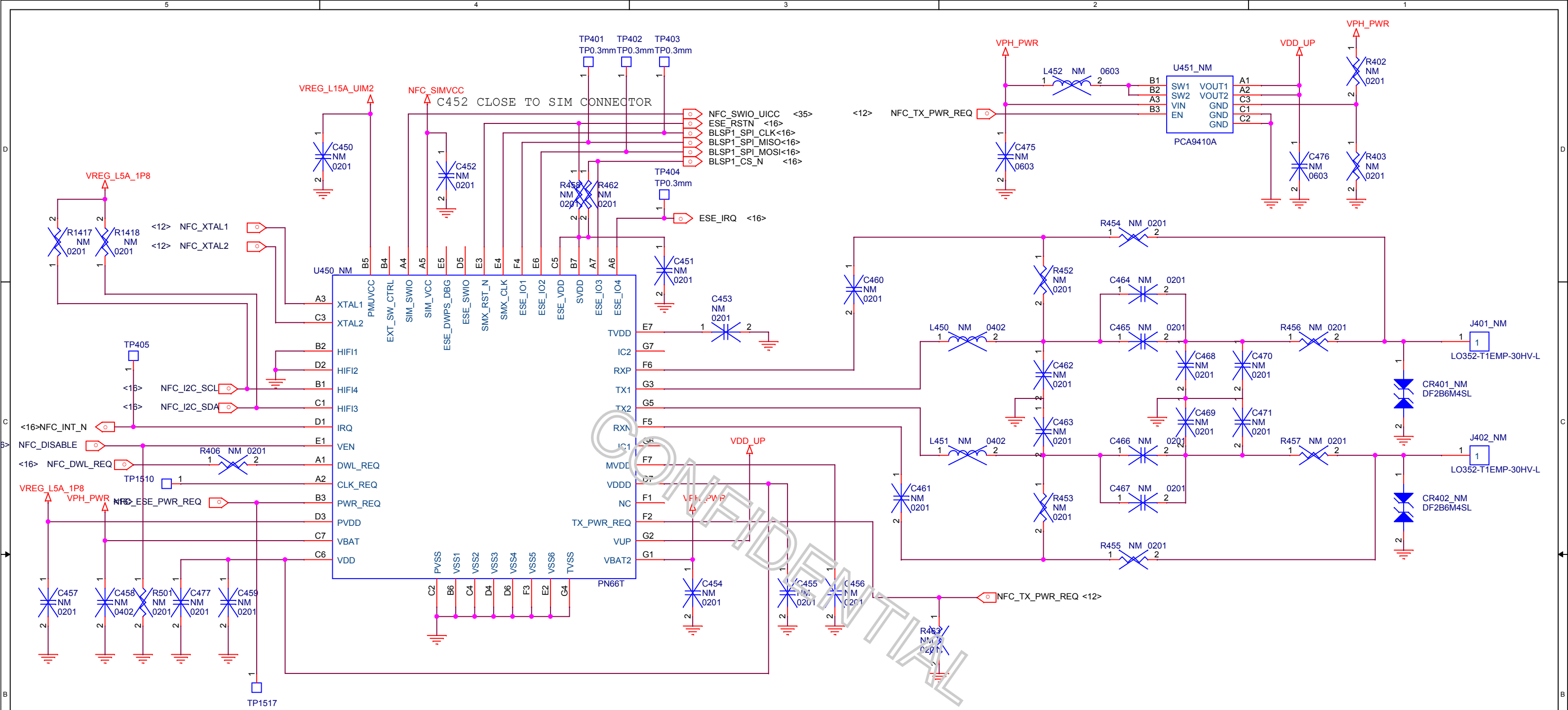

NFC

Title		A1
Size	Document Number	Rev P0
A3	<Doc>	
Date:	Thursday, January 21, 2016	Sheet 6 of 41

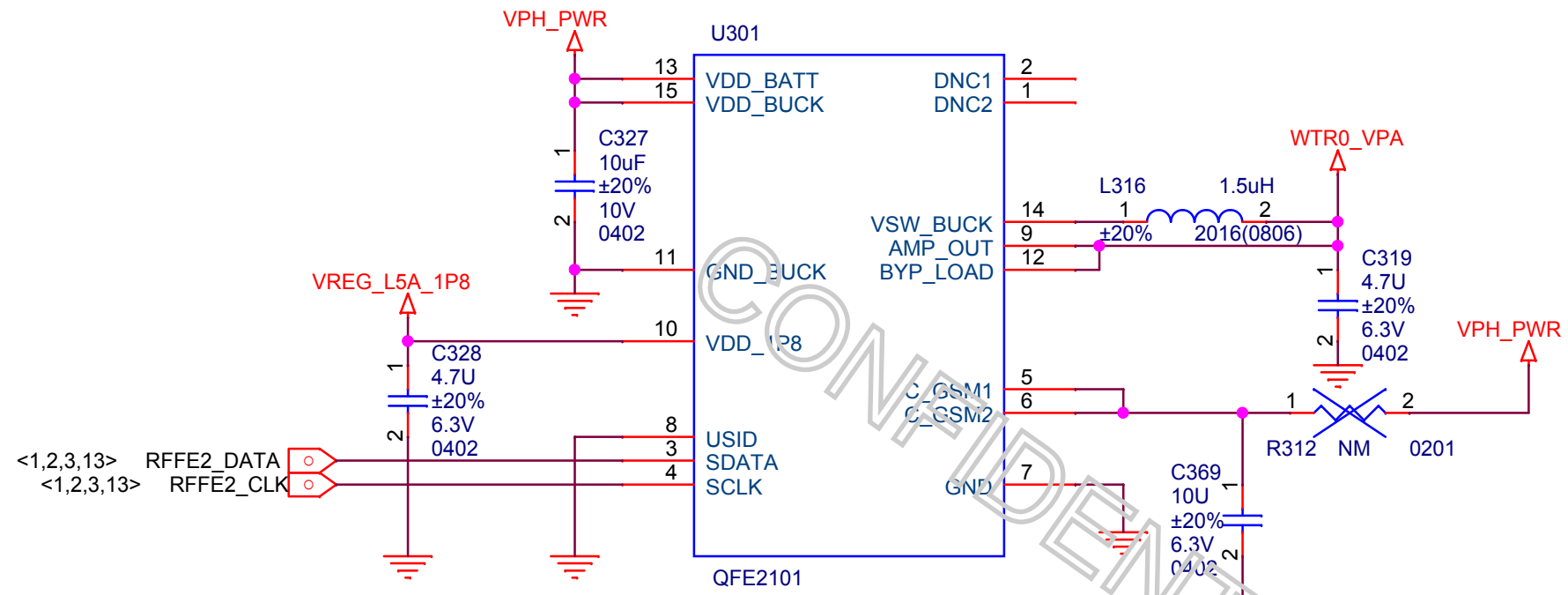

Title		
B3		
Size	Document Number	Rev
A4	<Doc>	P0
Date:	Friday, February 19, 2016	Sheet 7 of 41

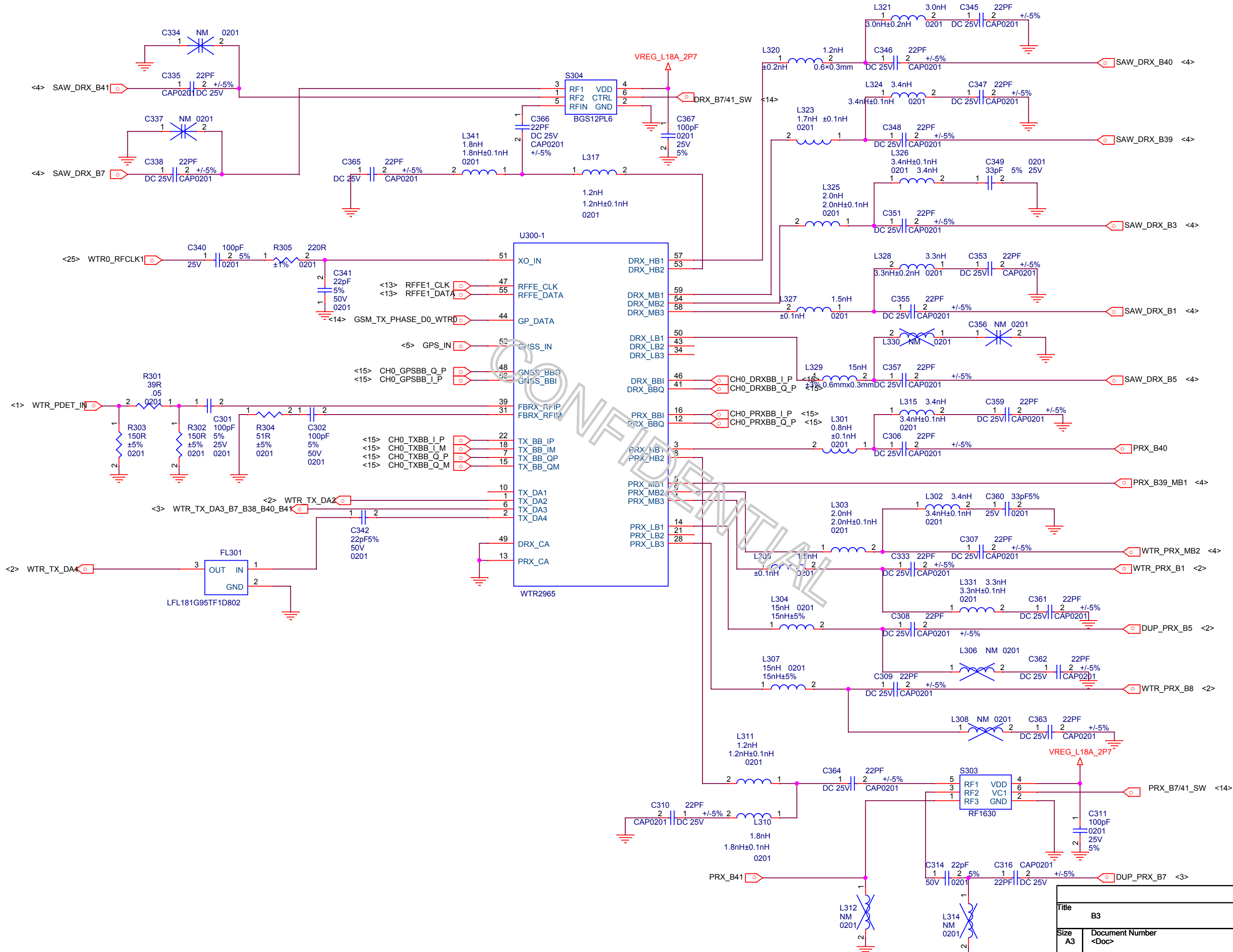

Title		
B3		
Size	Document Number	Rev
A3	<Doc>	P0
Date:	Thursday, January 21, 2016	Sheet 8 of 41

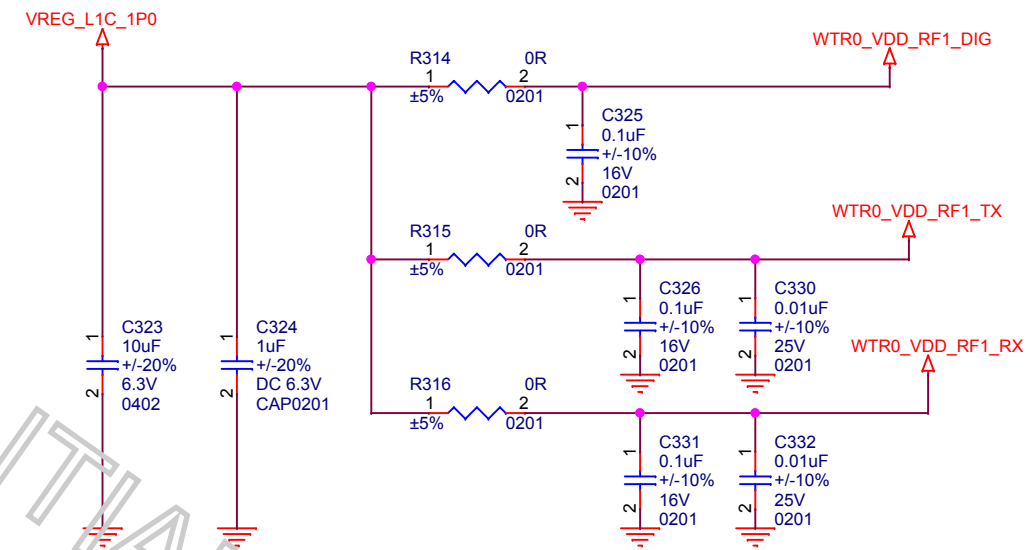
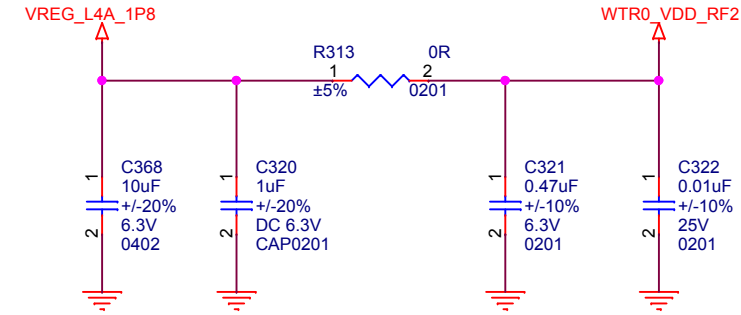
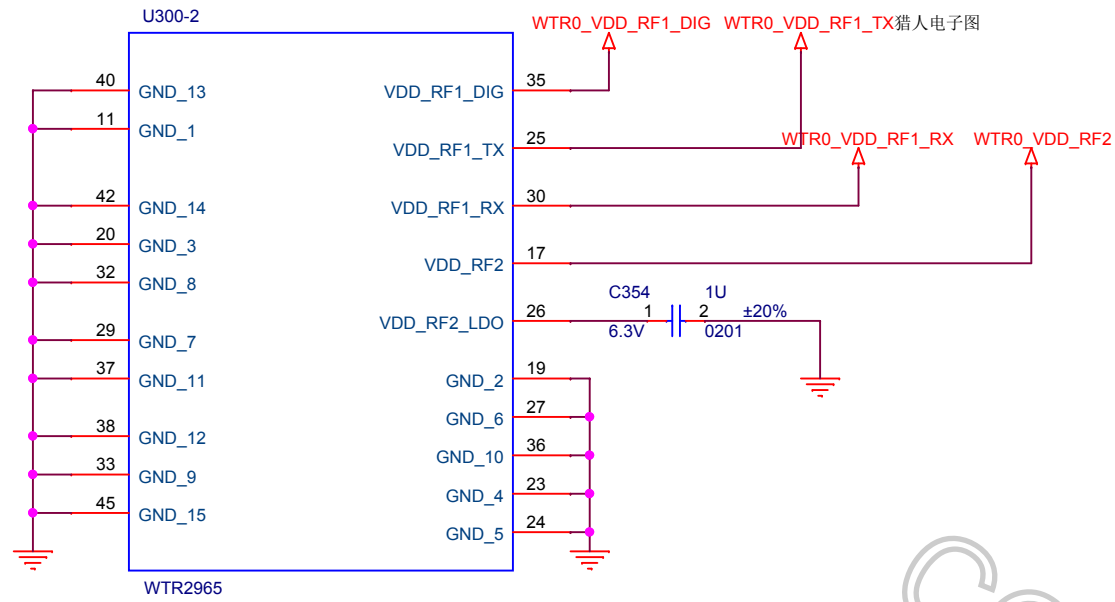

CONFIDENTIAL

Title		
B3		
Size	Document Number	Rev
A3	<Doc>	P0
Date:	Thursday, January 21, 2016	Sheet 9 of 41

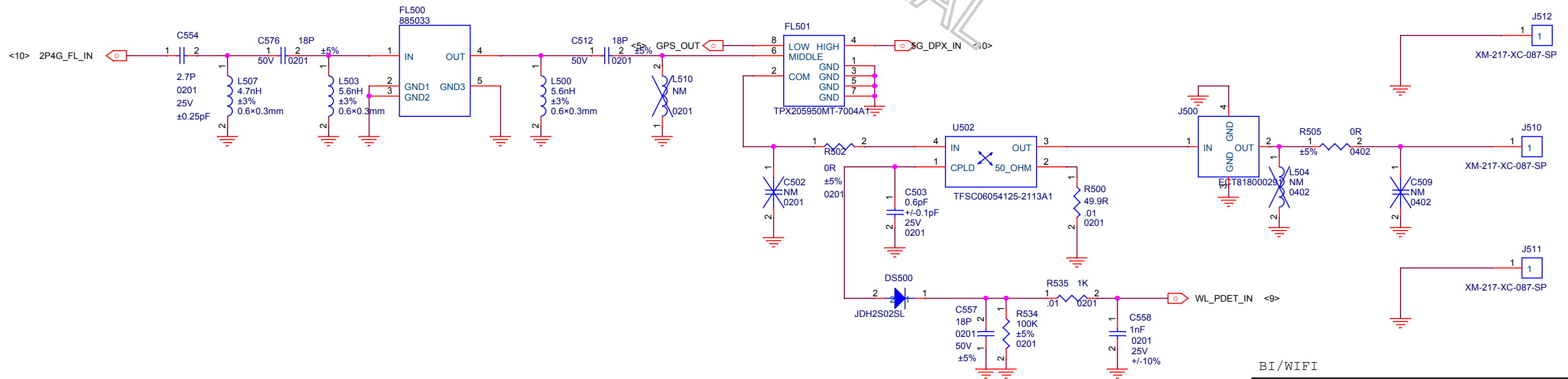
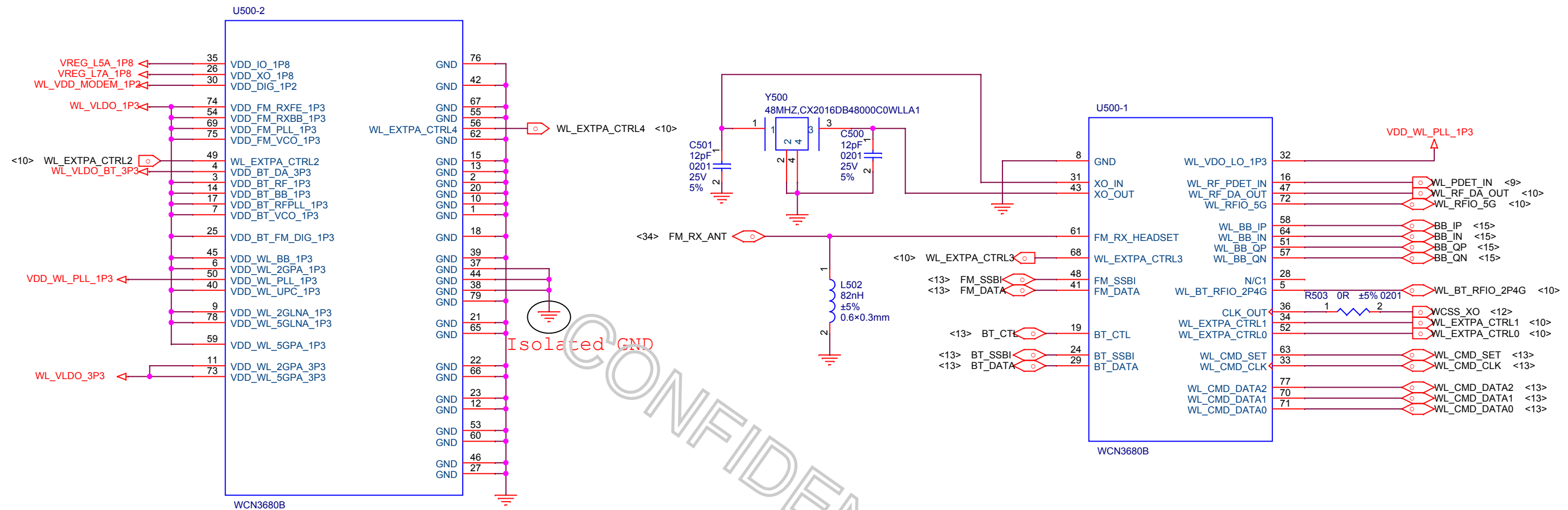

BI/WIFI

Title		
B3		
Size	Document Number	Rev
A3	<Doc>	P0
Date:	Wednesday, March 16, 2016	Sheet 10 of 41

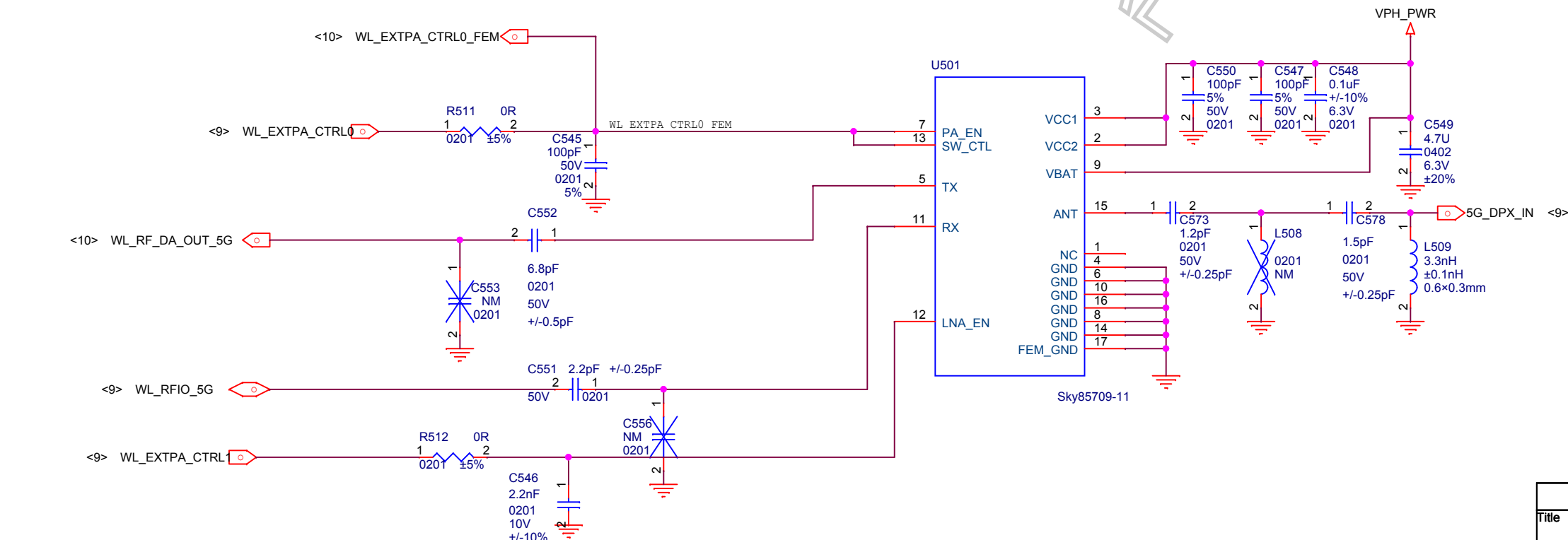
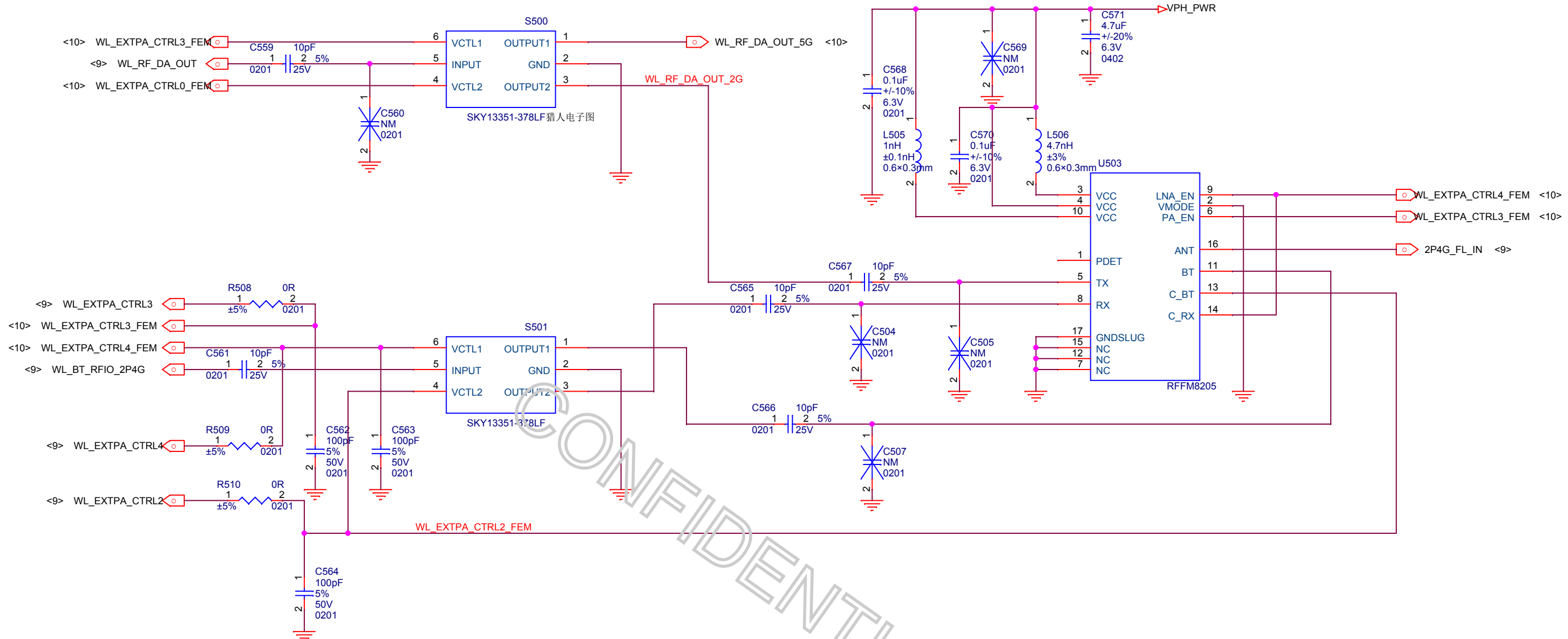

Title		
B3		
Size	Document Number	Rev
A3	<Doc>	P0
Date:	Tuesday, February 23, 2016	Sheet 11 of 41

Voltage	Pad name	Pad no.	Max curre
1P3	VDD_BT_FM_DIG_1P3	25	1
	VDD_BT_BB_1P3	14	1
	VDD_BT_PLL_1P3	17	8
	VDD_BT_RXRF_1P3	3	10
	VDD_BT_VCO_1P3	7	8
	VDD_FM_PLL_1P3	69	16
	VDD_FM_RXBB_1P3	54	
	VDD_FM_RXFE_1P3	74	
	VDD_FM_VCO_1P3	75	
	VDD_WL_2GLNA_1P3	9	10
	VDD_WL_2GPA_1P3	6	85
	VDD_WL_5GLNA_1P3	78	155
	VDD_WL_5GPA_1P3	59	
	VDD_WL_BB_1P3	45	
	VDD_WL_LO_1P3	32	
VDD_WL_PLL_1P3	50	10	
VDD_WL_UPC_1P3	40	30	
1P8	VDD_XO_1P8	26	2
	VDD_IO_1P8	35	1
3P0	VDD_FM_TXDA_3P0	49	16
	VDD_WL_2GPA_3P0	11	560
	VDD_WL_5GPA_3P0	73	600
	VDD_BT_TXRF_3P0	4	45
1P2	VDD_DIG_1P2	30	4

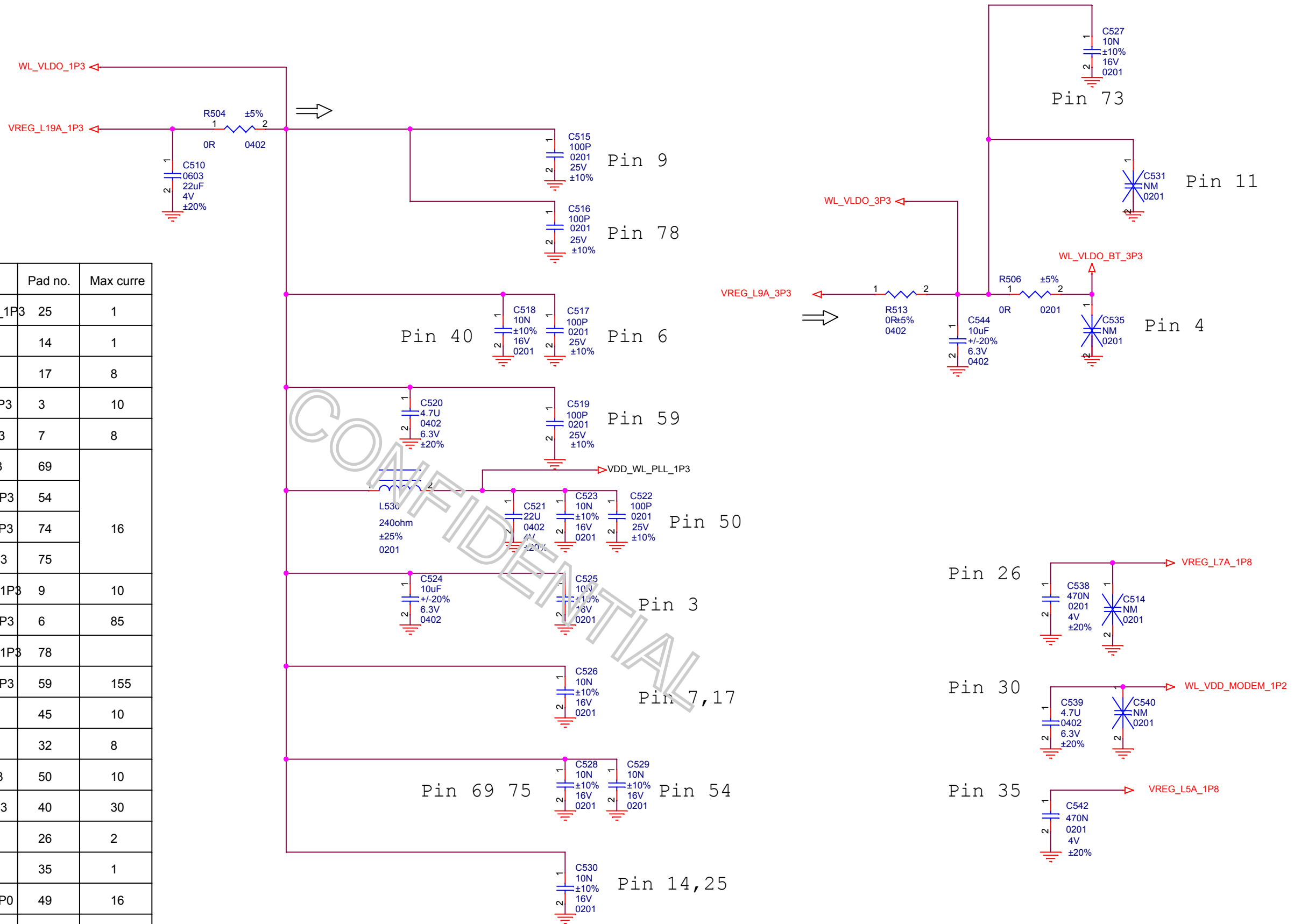

BT/FM/WLAN DECOUP

Title B3		
Size A3	Document Number <Doc>	Rev P0
Date: Thursday, February 25, 2016	Sheet 12	of 41

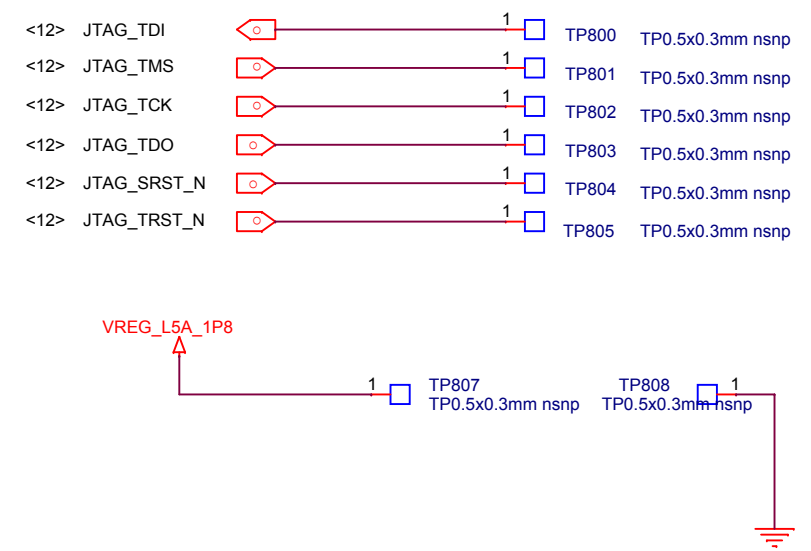
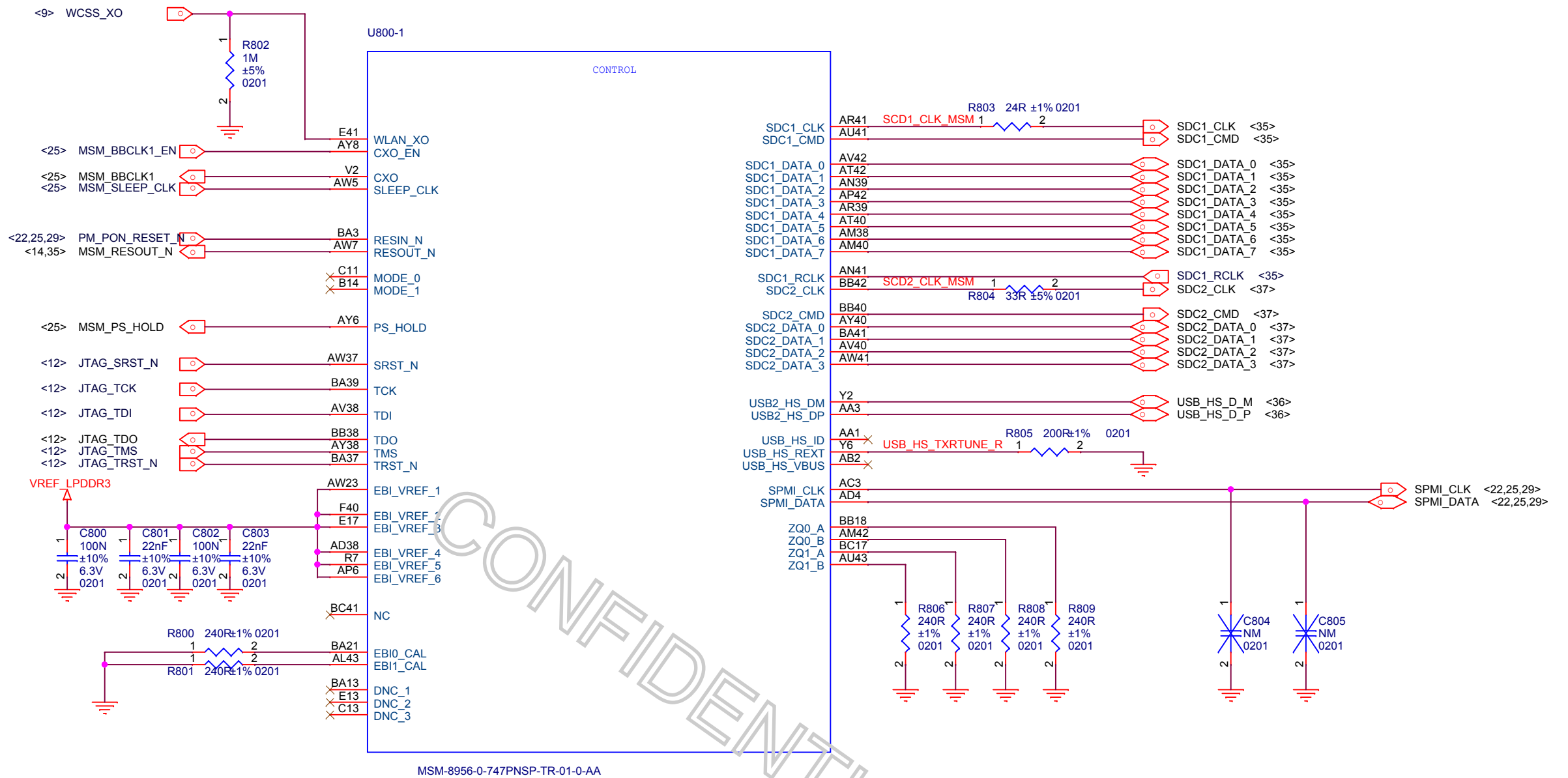

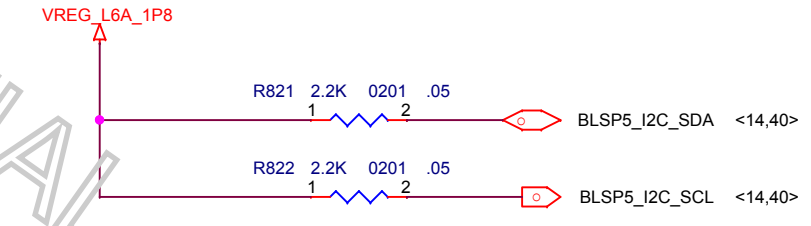
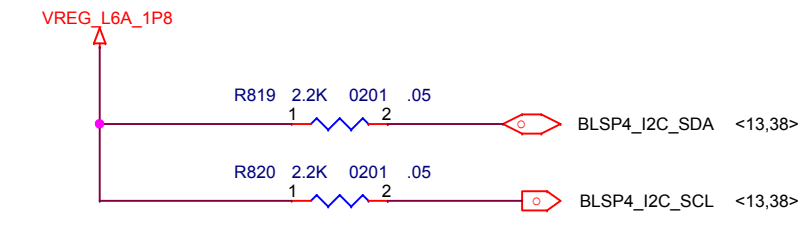
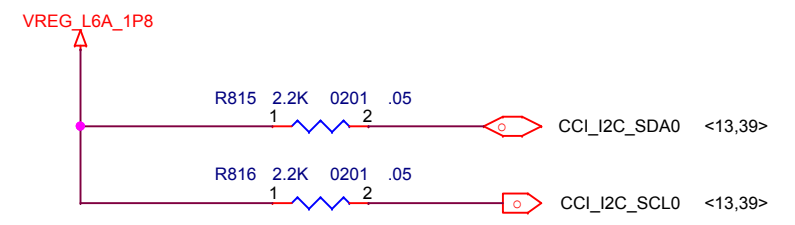
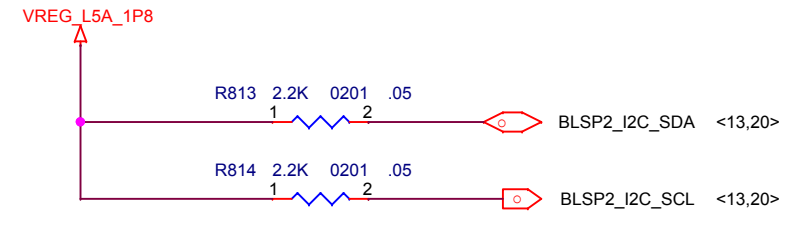
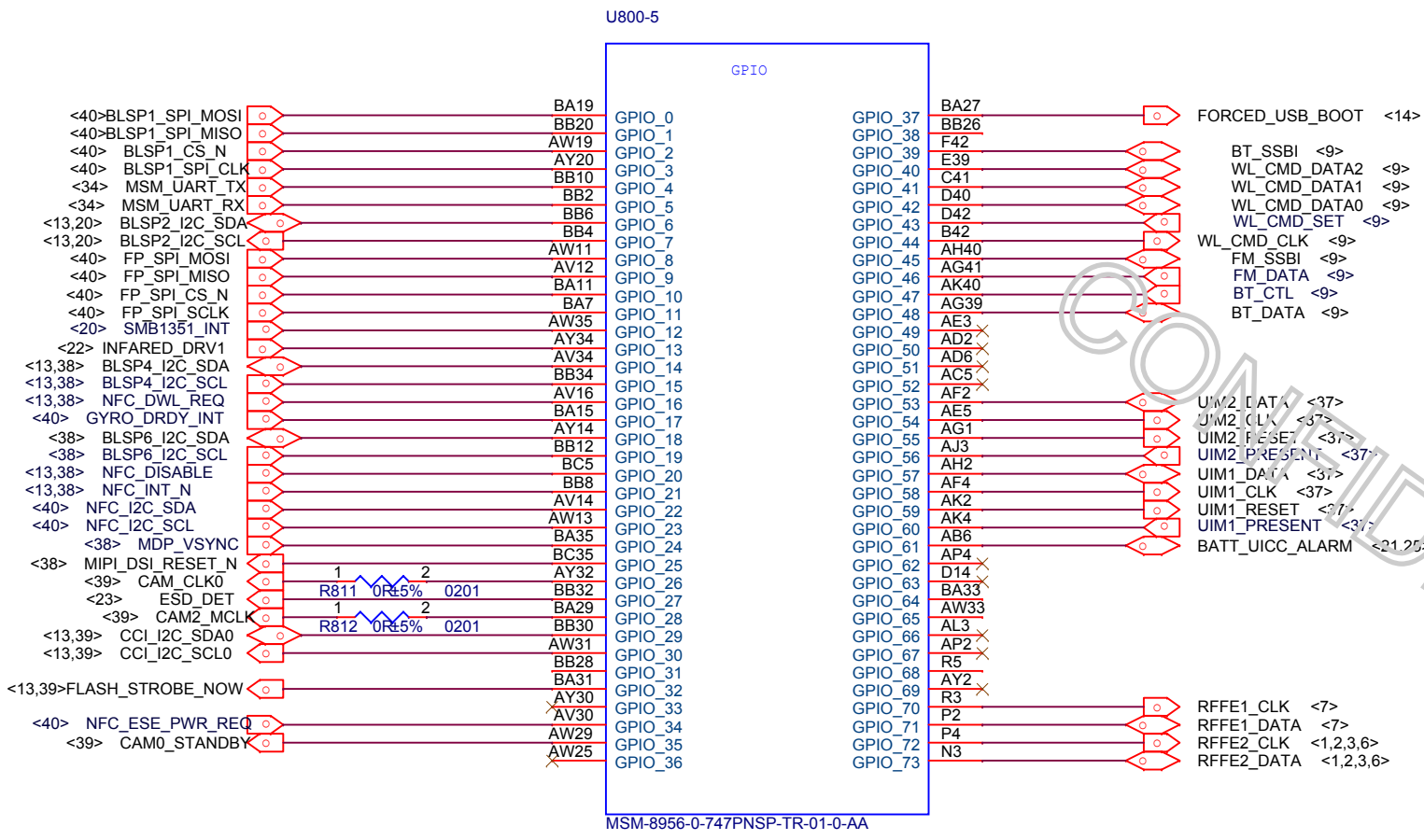

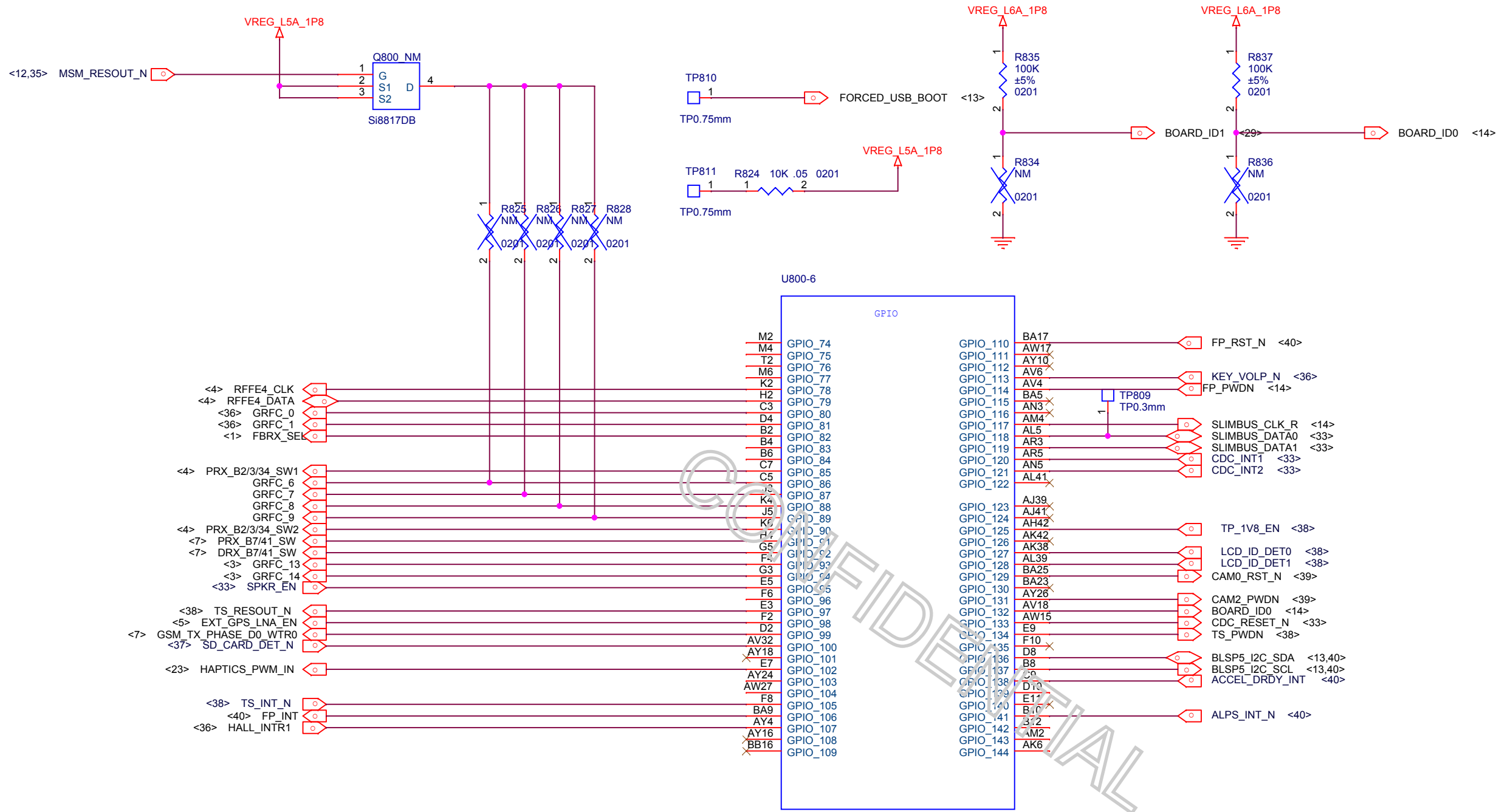

MSM-8956-0-747PNSP-TR-01-0-AA

CAD NOTE: PLACE RC FLITER CLOSE TO MSM

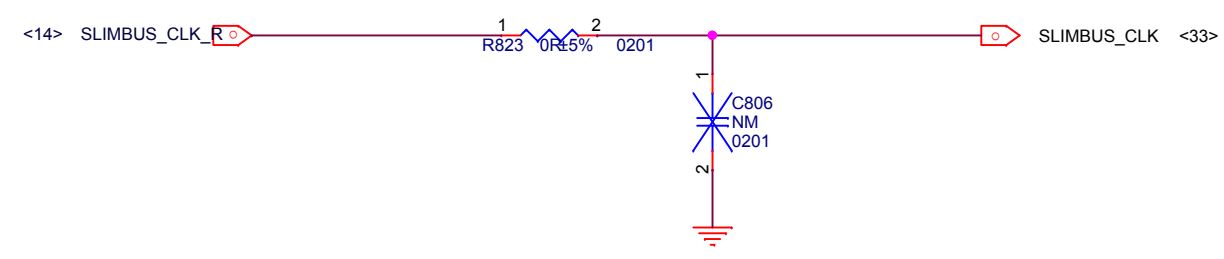

Title		
B3		
Size	Document Number	Rev
A3	<Doc>	P0
Date:	Tuesday, February 23, 2016	Sheet 15 of 41

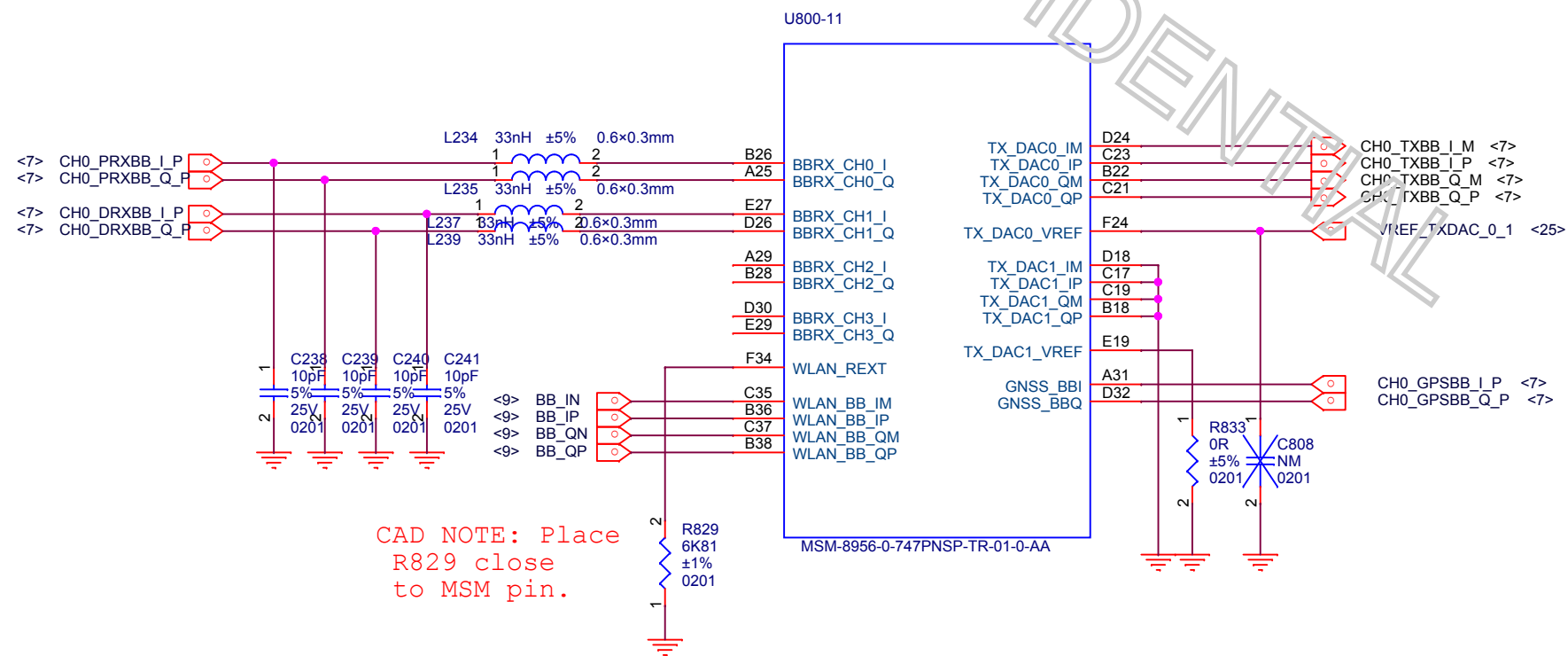
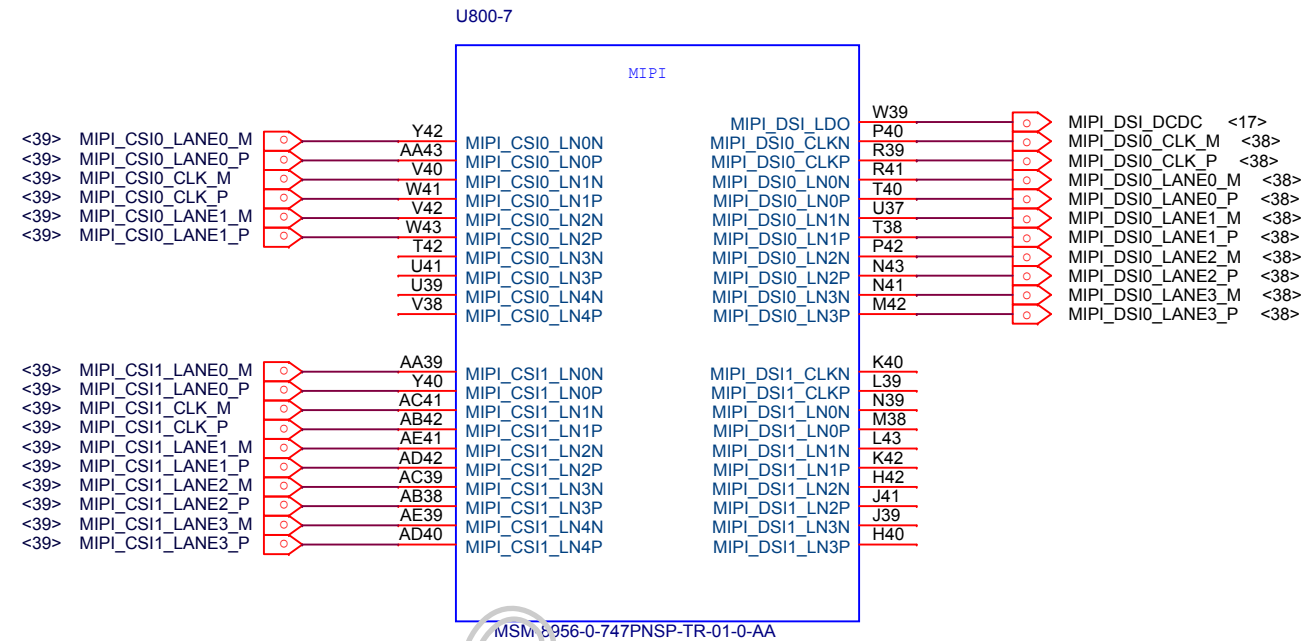

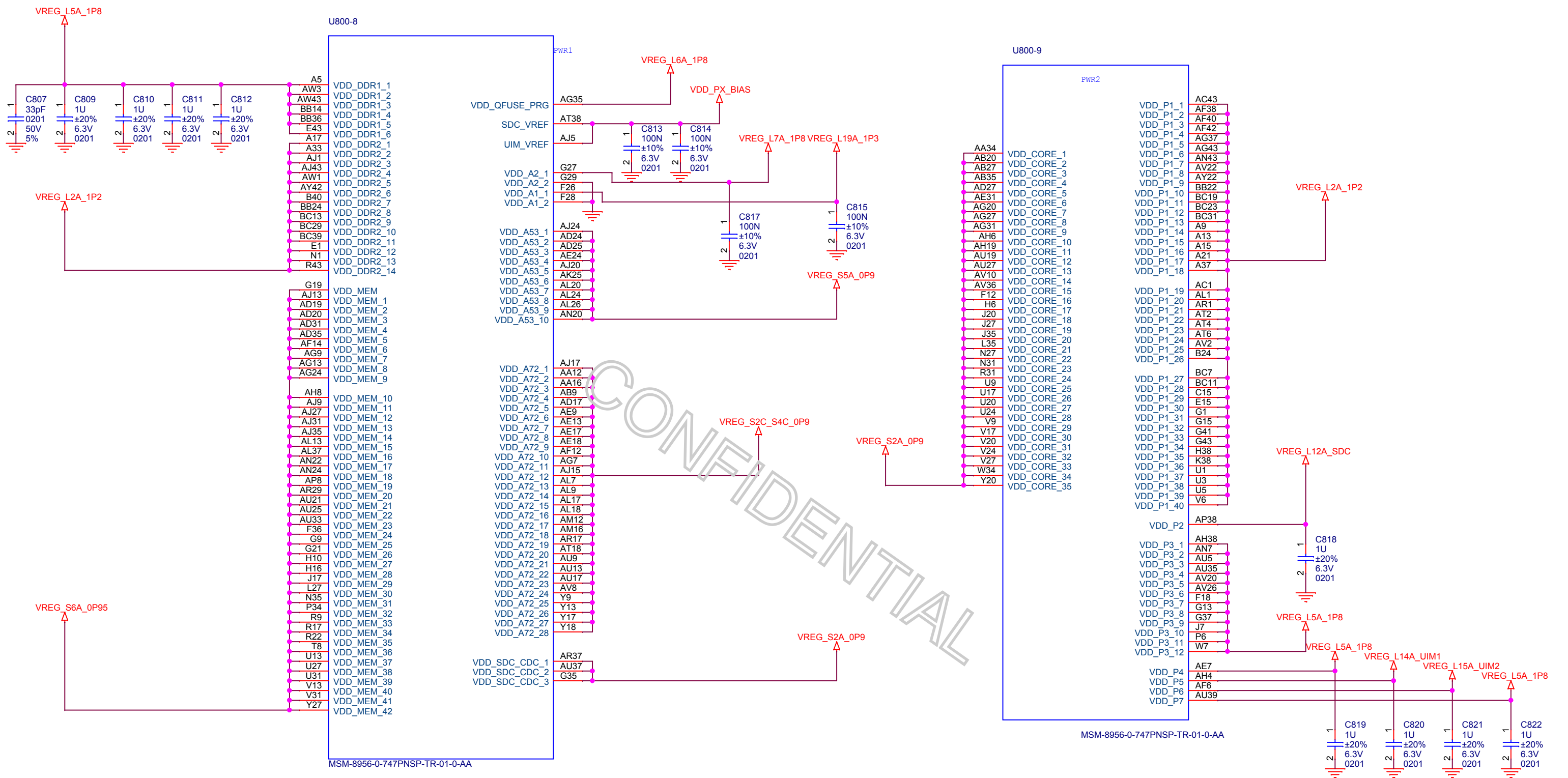

CONFIDENTIAL

Title		
B3		
Size	Document Number	Rev
A3	<Doc>	P0
Date:	Wednesday, February 24, 2016	Sheet 17 of 41

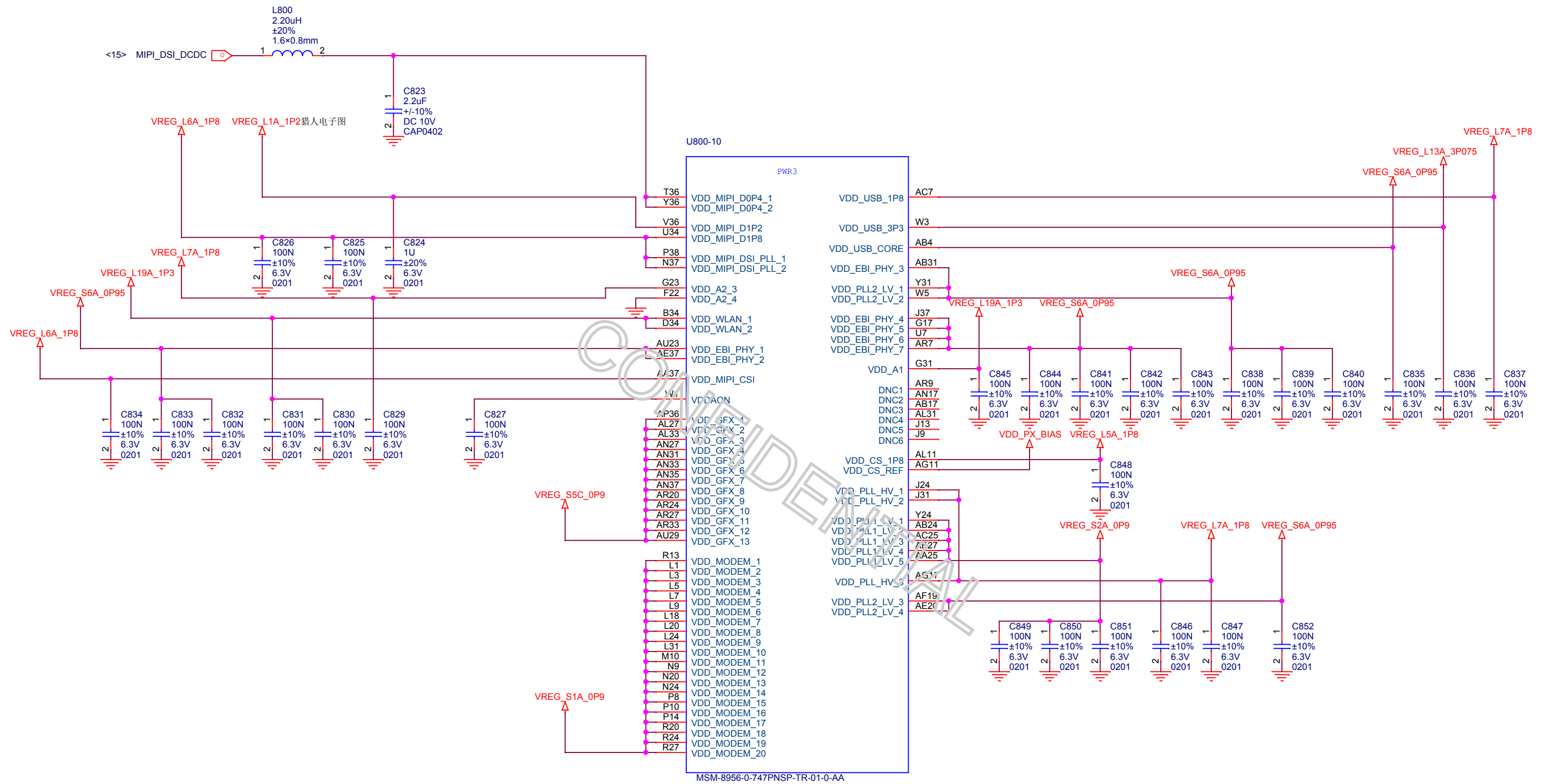

Title		
B3		
Size	Document Number	Rev
A3	<Doc>	P0
Date:	Thursday, January 21, 2016	Sheet 18 of 41

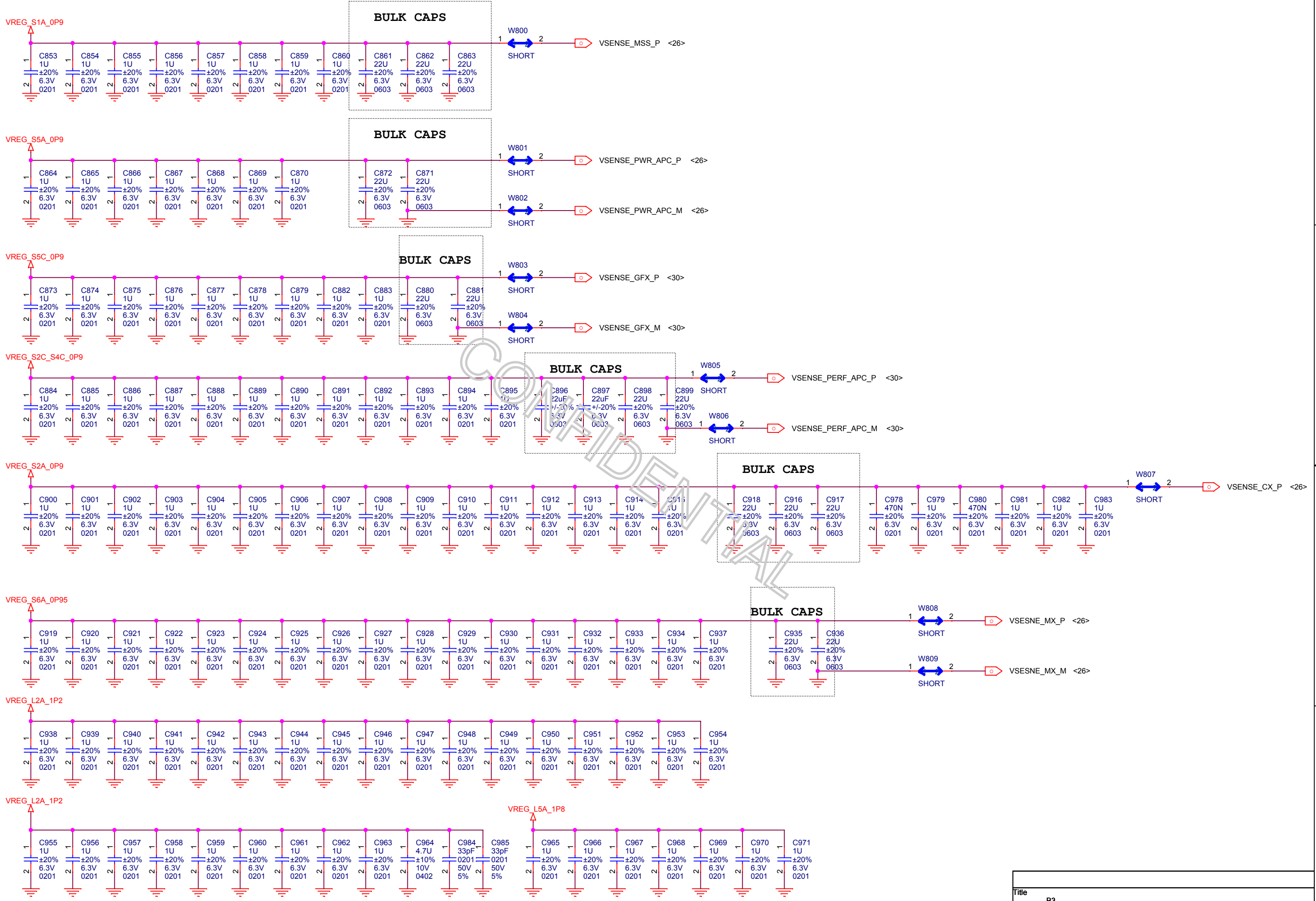

Title		
B3		
Size	Document Number	Rev
A3	<Doc>	P0
Date:	Wednesday, February 24, 2016	Sheet 19 of 41

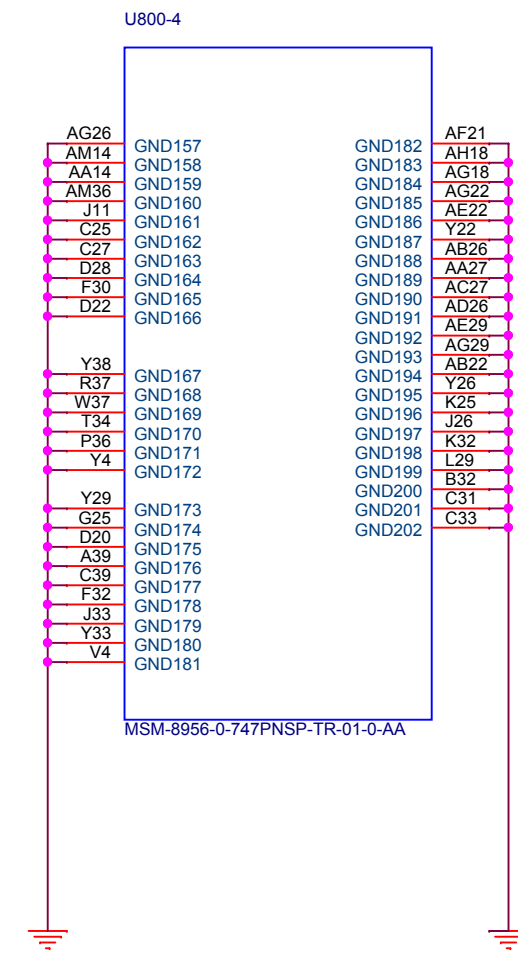
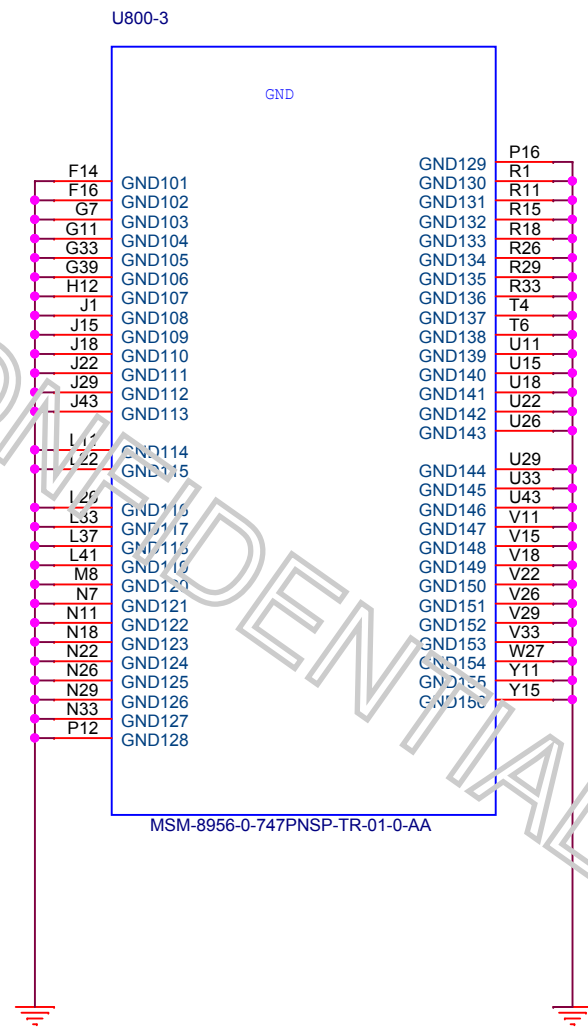
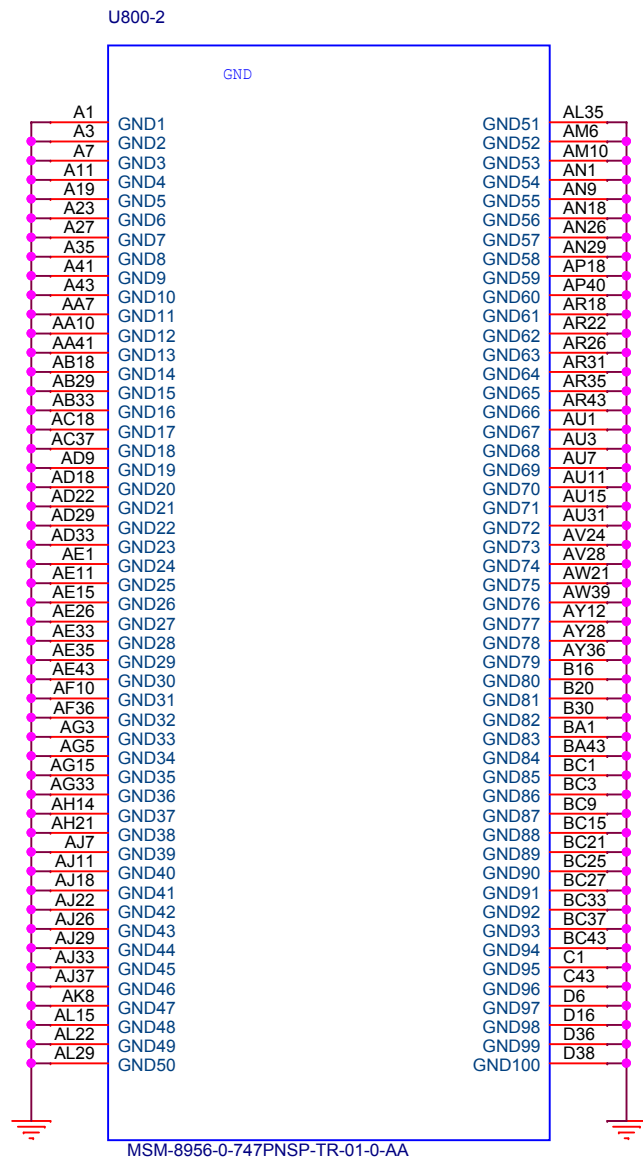

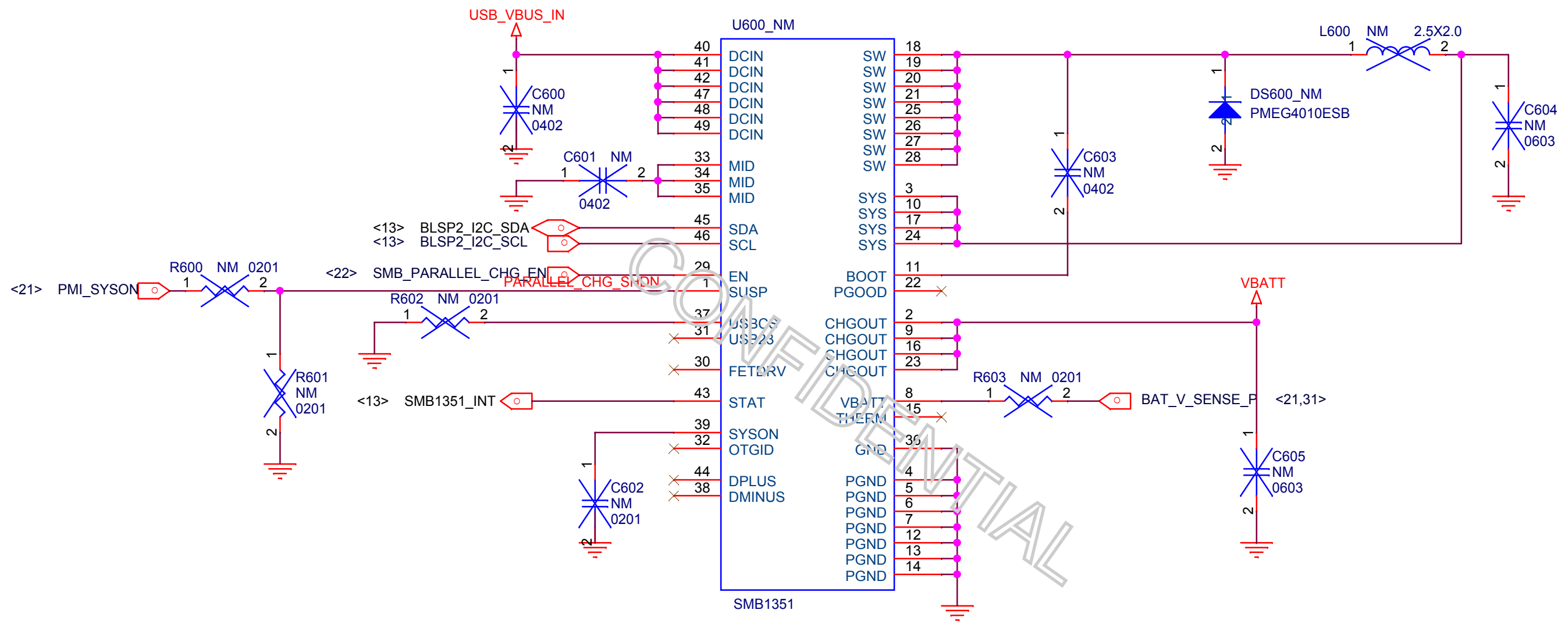

Title		
B3		
Size	Document Number	Rev
A4	<Doc>	P0
Date:	Thursday, January 21, 2016	Sheet 21 of 41

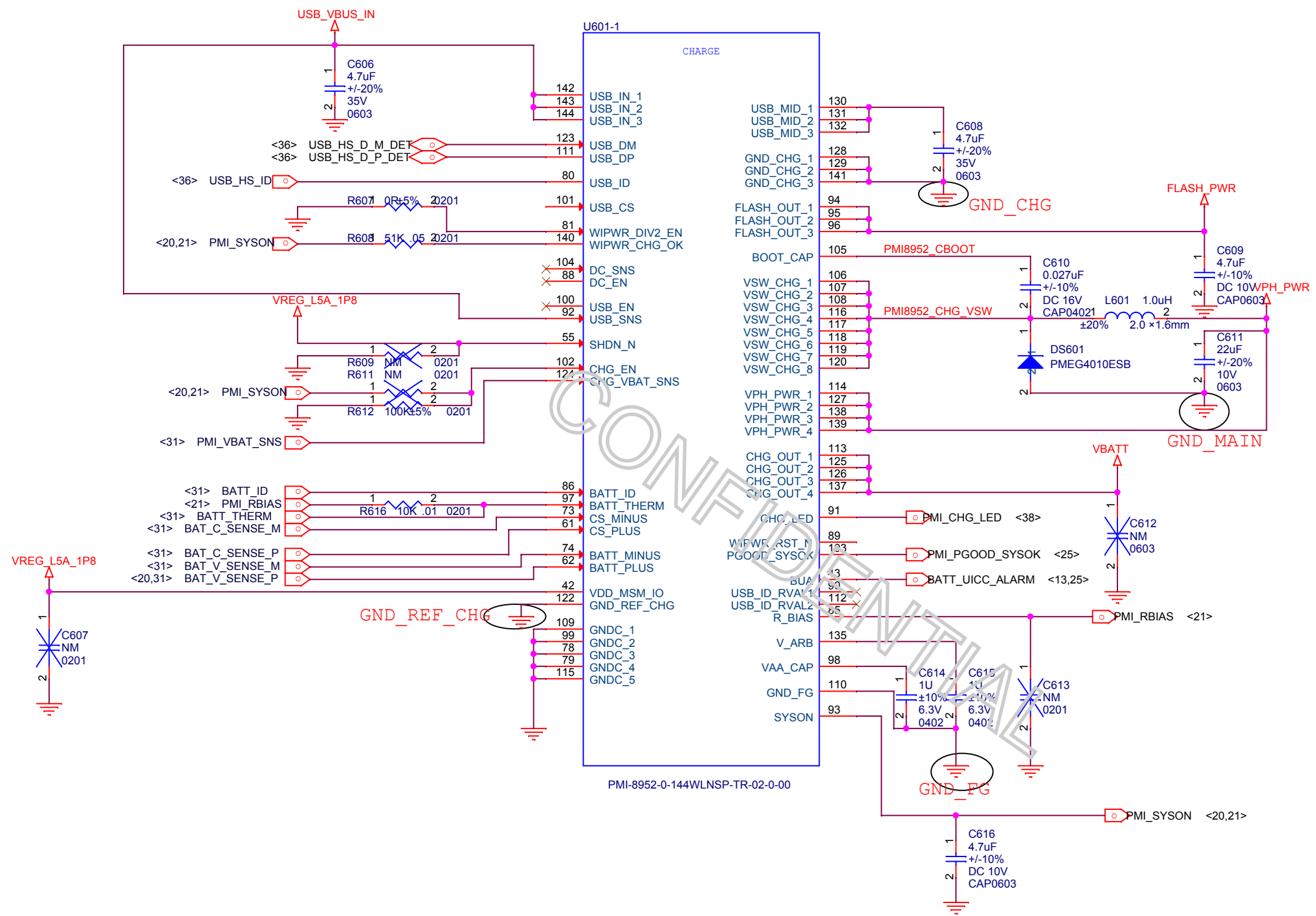

Title		
B3		
Size	Document Number	Rev
A3	<Doc>	P0
Date:	Tuesday, February 23, 2016	Sheet 22 of 41

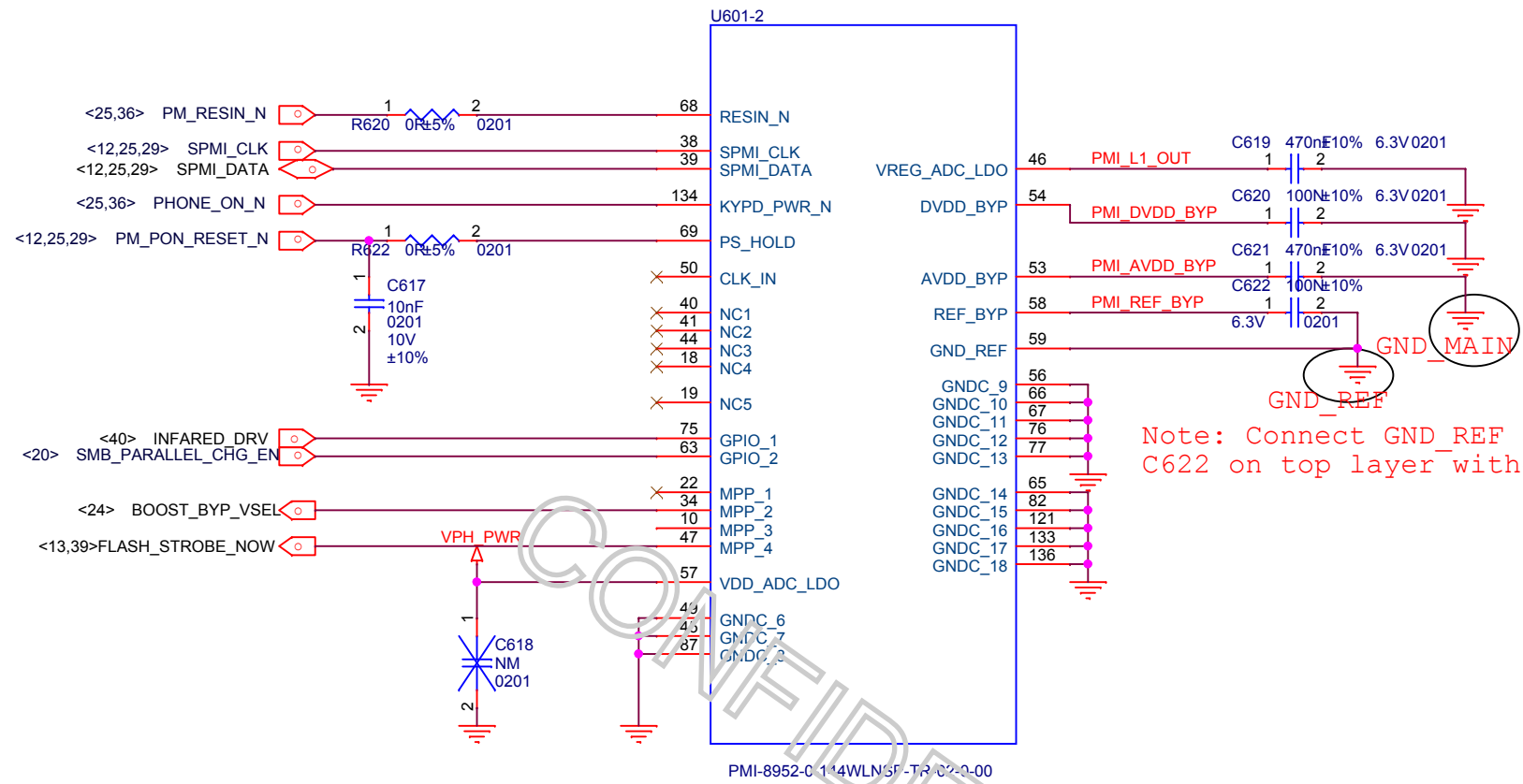

MPP	ADC Input	Analog function
MPP1	Only if NOT using parallel charging	Analog output
MPP2	NO	Current sink
MPP3	NO	Analog output
MPP4	NO	Current sink

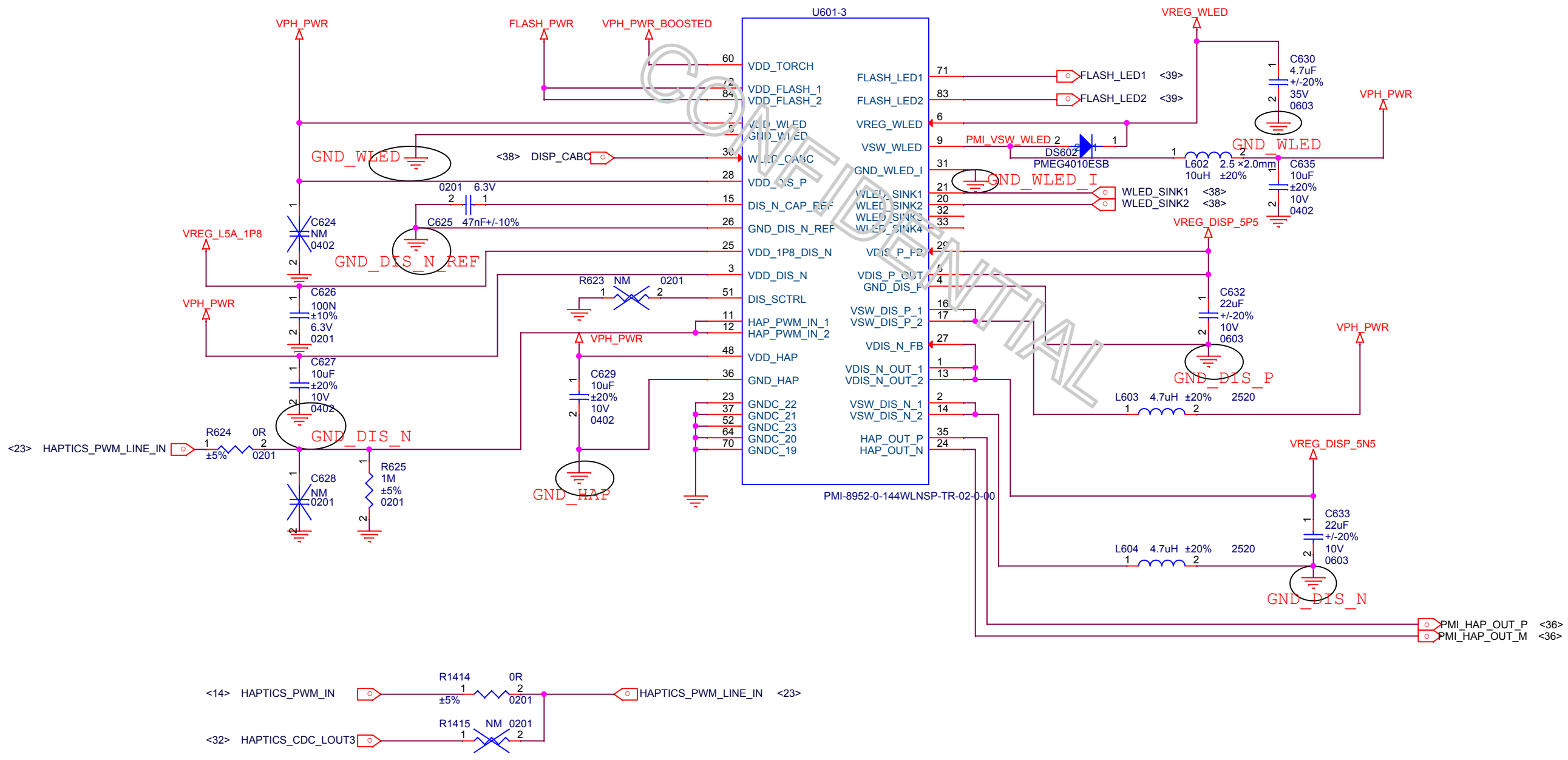

Title		
B3		
Size	Document Number	Rev
A3	<Doc>	P0
Date:	Monday, March 14, 2016	Sheet 24 of 41

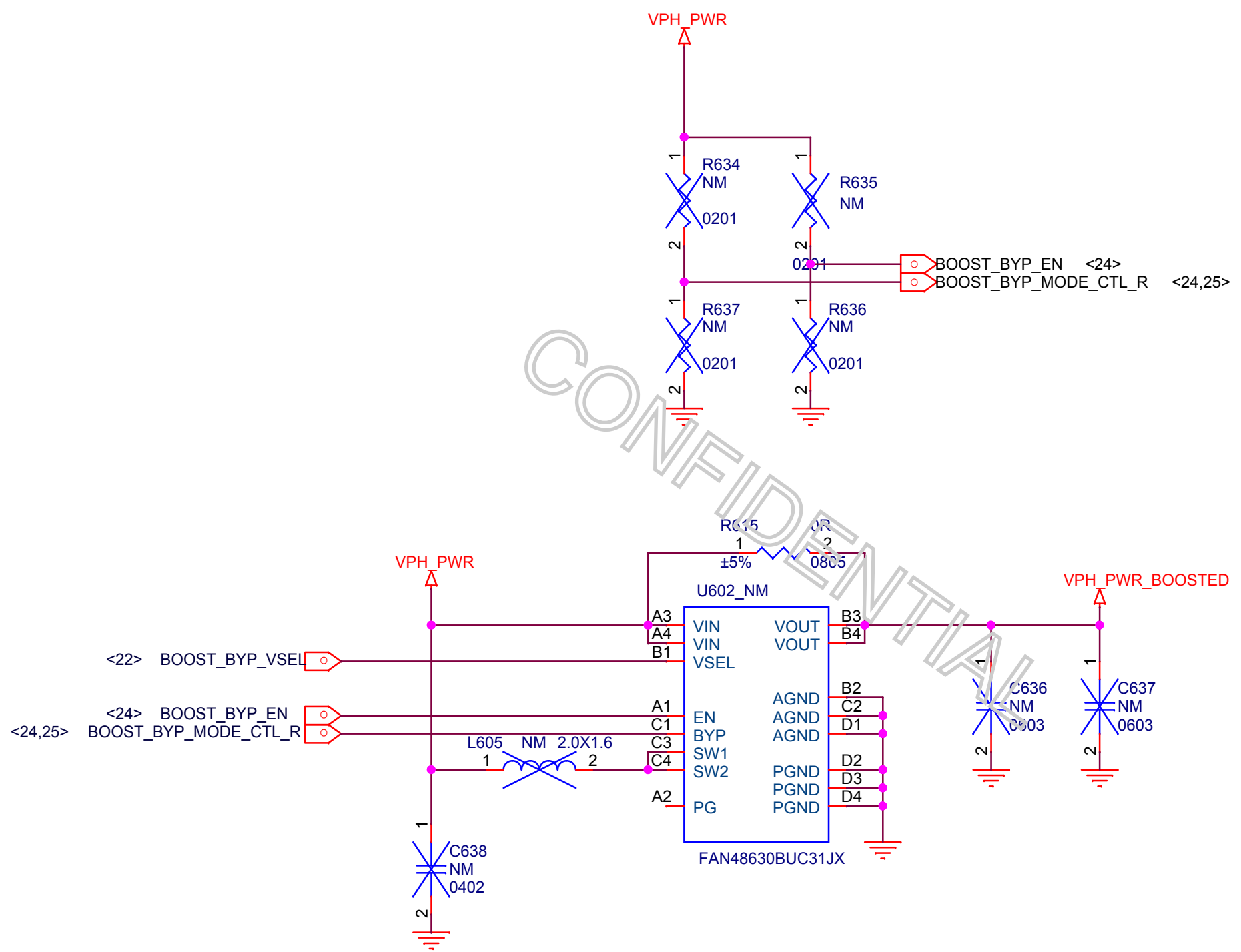

VSEL = 0 --> VOUT = 3.15V
 VSEL = 1 --> VOUT = 3.60V

Title		
B3		
Size	Document Number	Rev
A4	<Doc>	P0
Date:	Thursday, January 21, 2016	Sheet 25 of 41

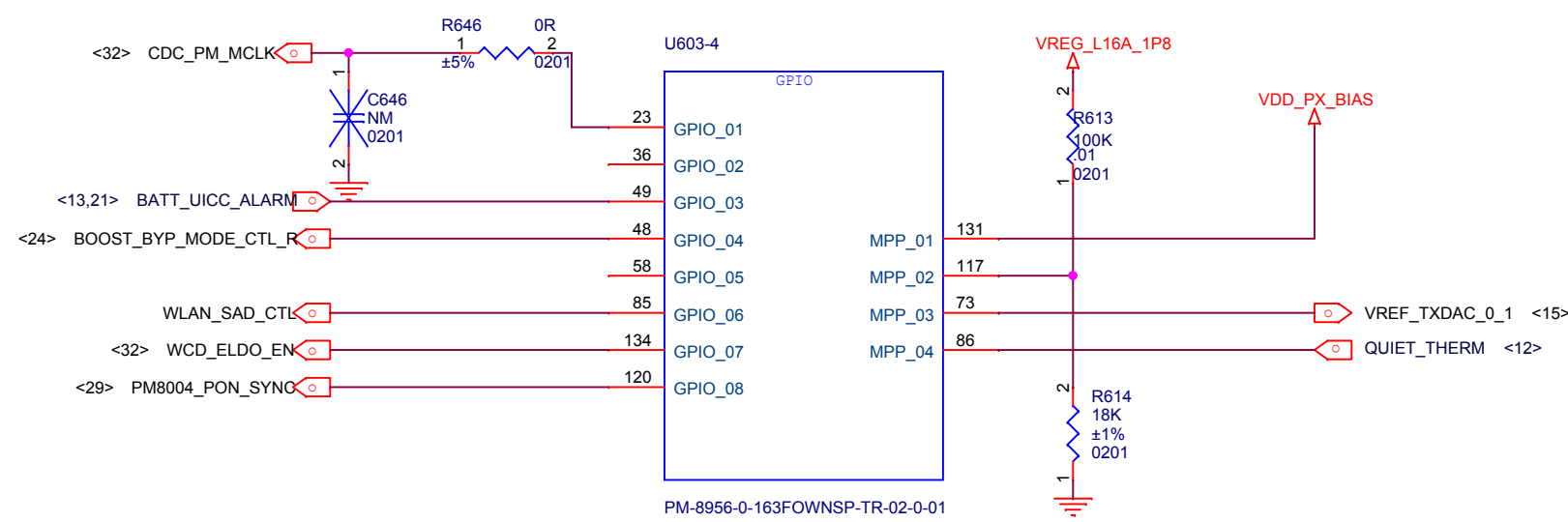
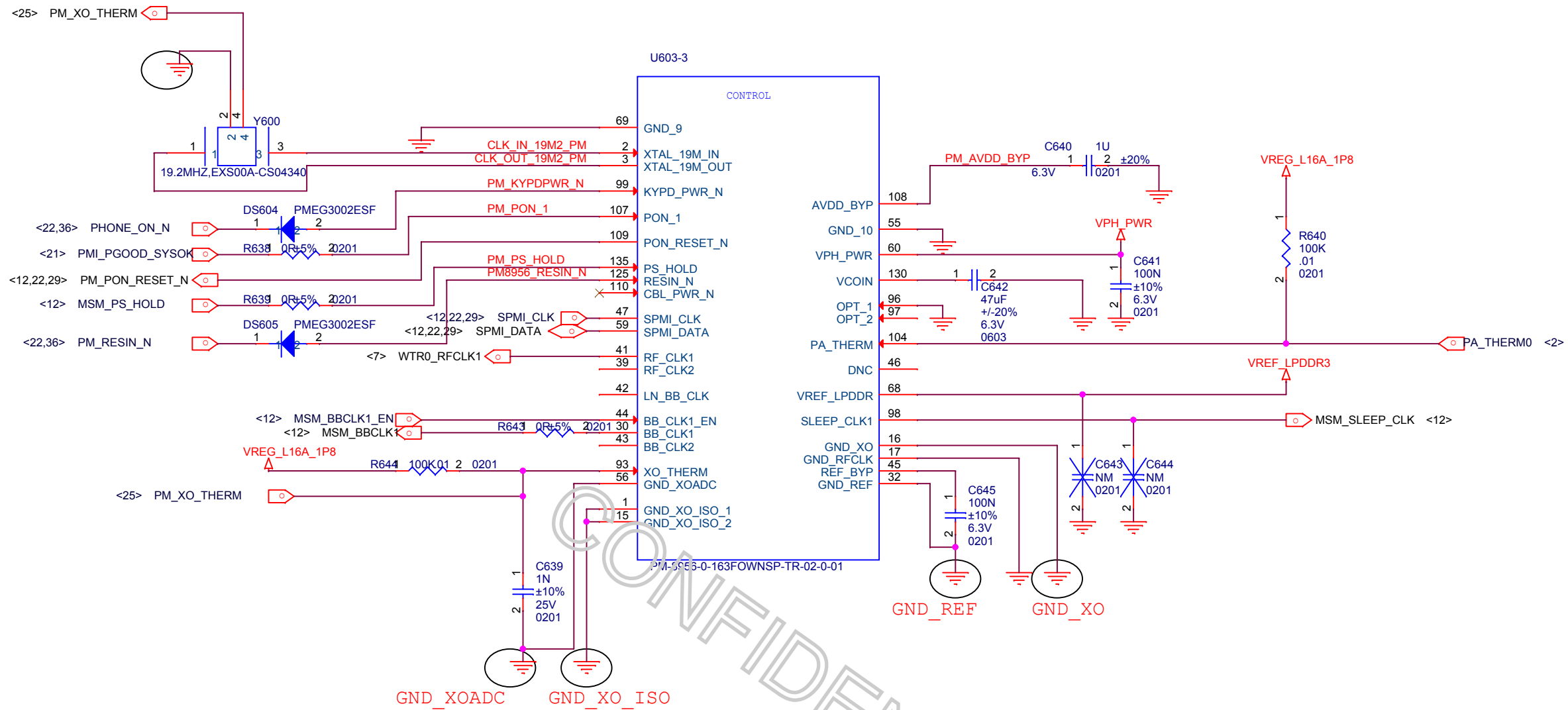

Title		
B3		
Size	Document Number	Rev
A3	<Doc>	P0
Date:	Monday, March 14, 2016	Sheet 26 of 41

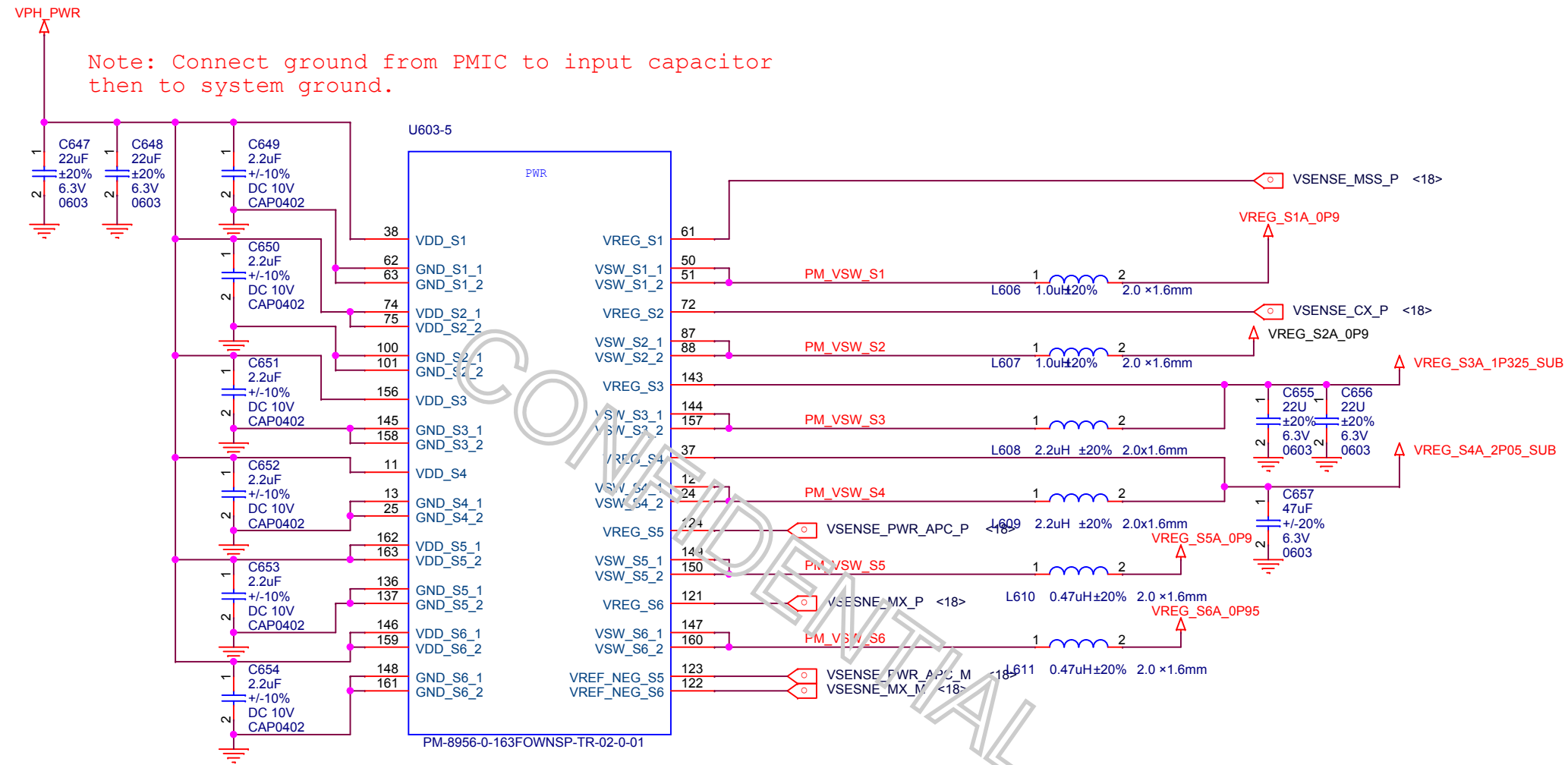

Title		
B3		
Size	Document Number	Rev
A3	<Doc>	P0
Date:	Friday, February 19, 2016	Sheet 27 of 41

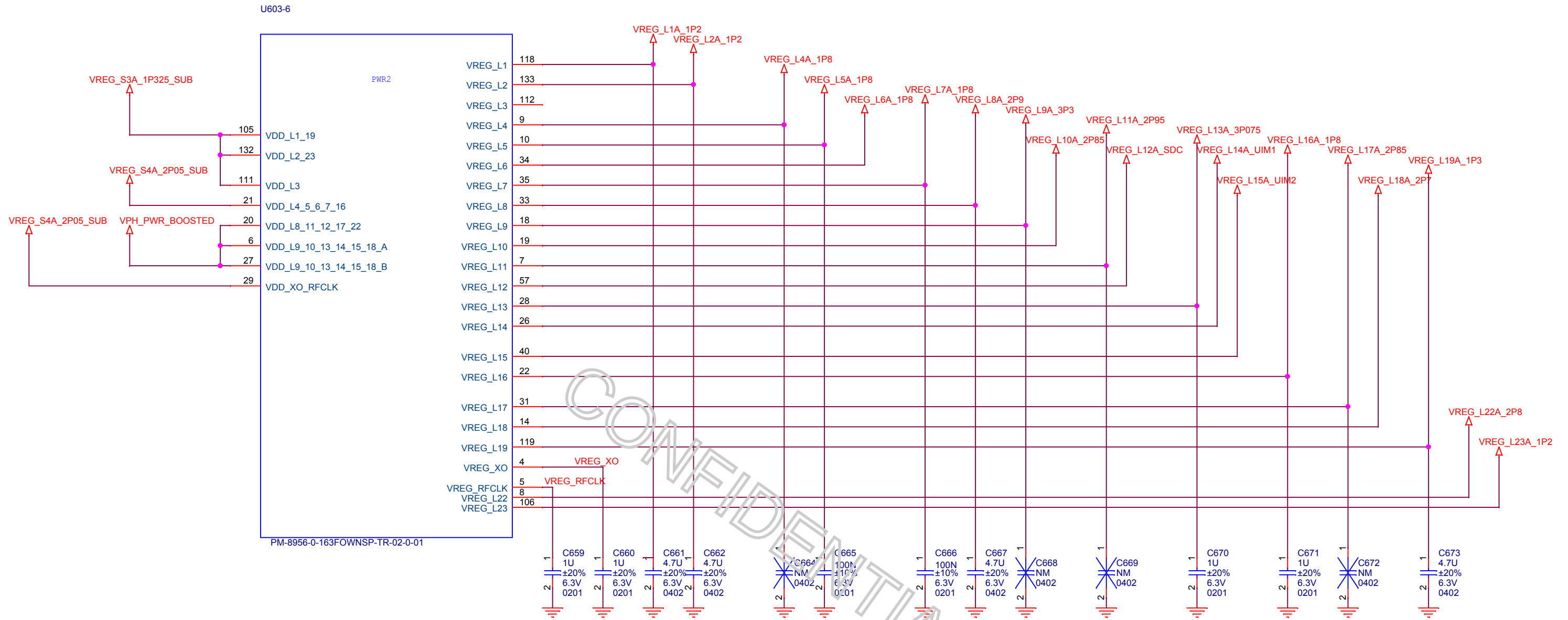

PSEUDO CAPLESS LDOs
 L4*, L6, L8, L9*, L10, L11*, L12, L14, L15, L17*, L18, L22, L23
 Please leave DNI placeholders until this schematic shows otherwise.
 L5, L7, L13, L16 have internal PMIC Loads and require local CAPs.

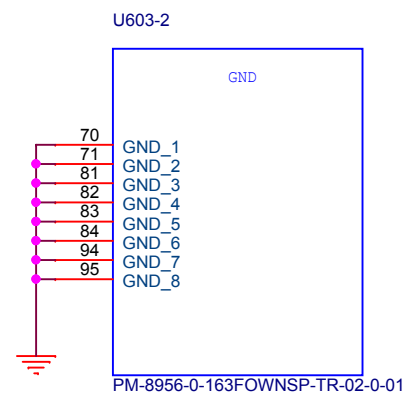

CAD NOTE: Create separate GND islands for PMIC and CODEC GND balls and star route them to GND plane. Remaining are PMIC GND balls.

Title		
B3		
Size	Document Number	Rev
A3	<Doc>	P0
Date:	Thursday, January 21, 2016	Sheet 28 of 41

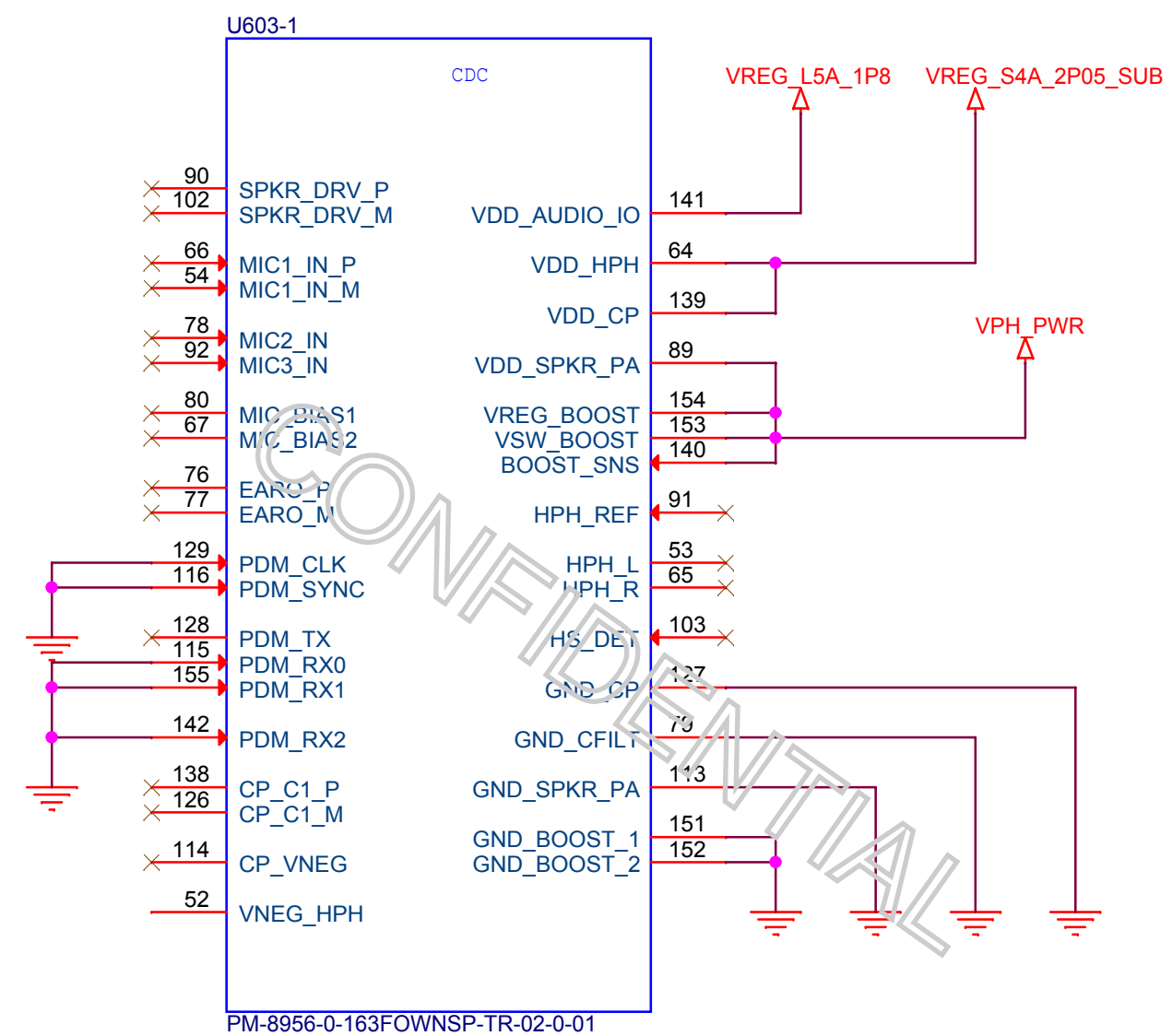

Title		
B3		
Size	Document Number	Rev
A4	<Doc>	P0
Date:	Tuesday, February 23, 2016	Sheet 29 of 41

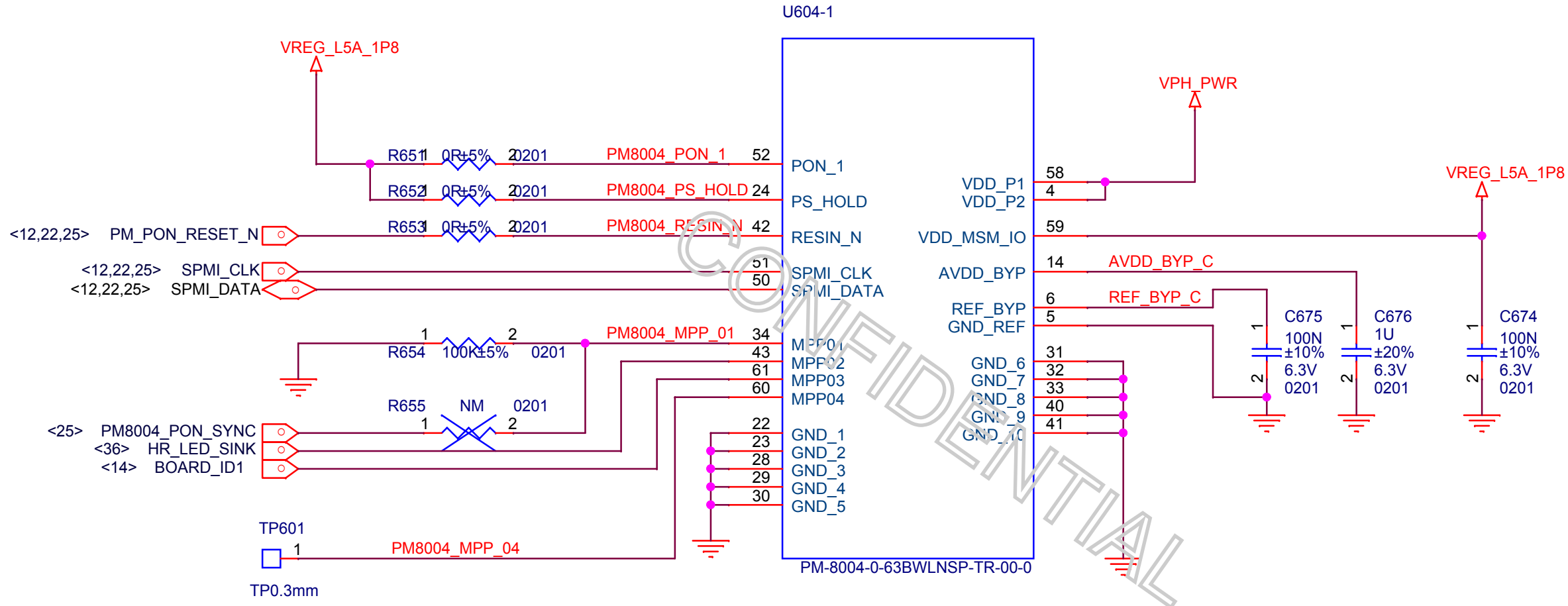

Title		
B3		
Size	Document Number	Rev
A4	<Doc>	P0
Date:	Thursday, January 21, 2016	Sheet 30 of 41

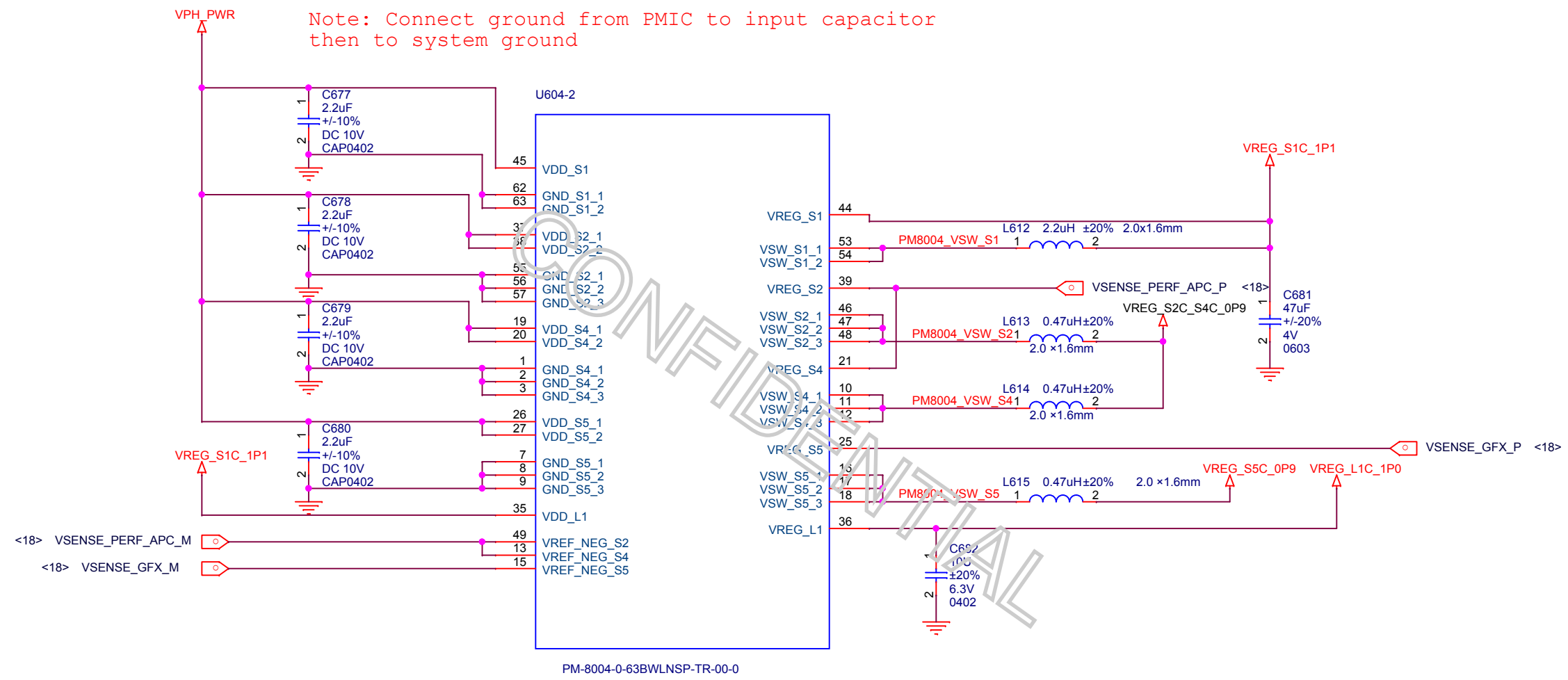

Title		
B3		
Size	Document Number	Rev
A3	<Doc>	P0
Date:	Thursday, January 21, 2016	Sheet 31 of 41

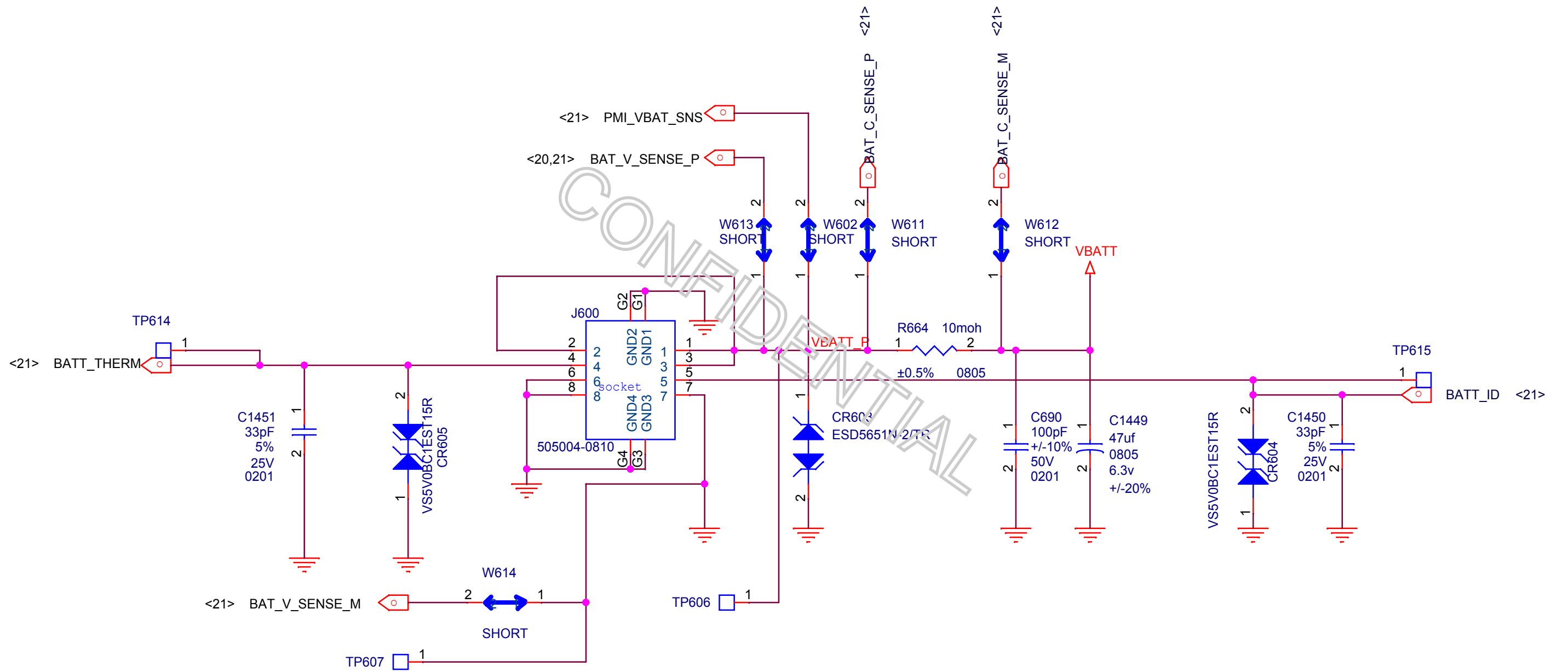

Title		
B3		
Size	Document Number	Rev
A4	<Doc>	P0
Date:	Thursday, January 21, 2016	Sheet 32 of 41

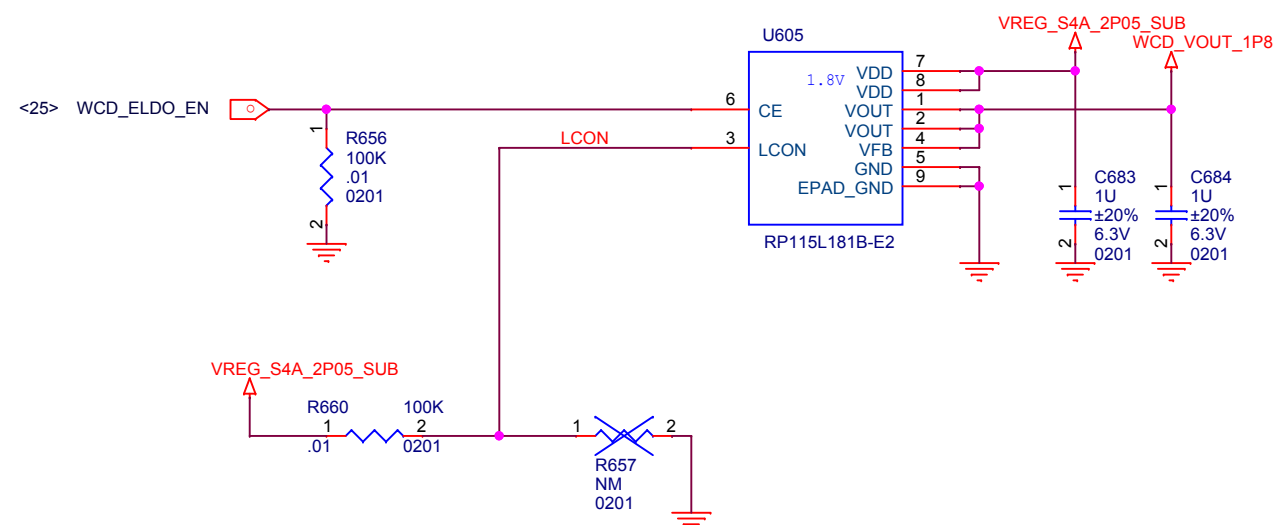
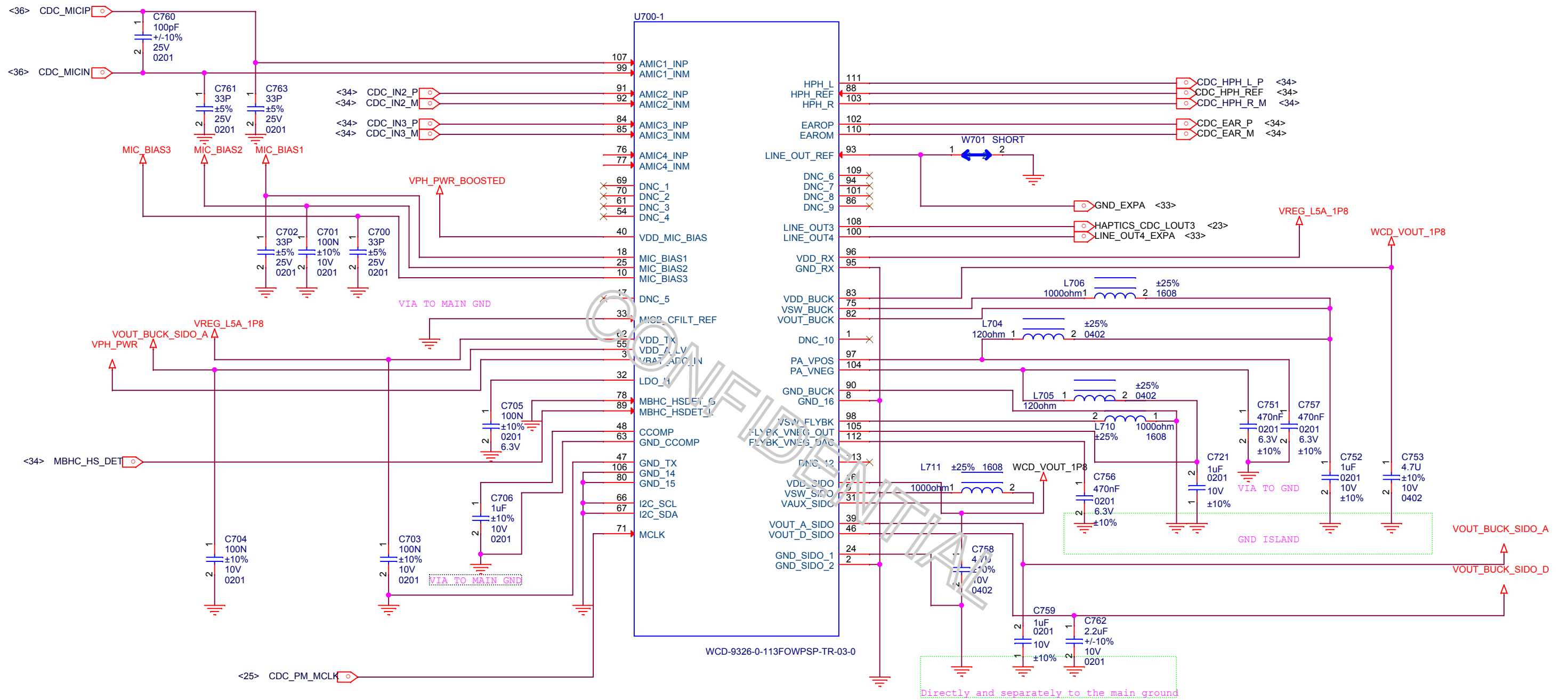

Title		
B3		
Size	Document Number	Rev
A3	<Doc>	P0
Date:	Thursday, January 21, 2016	Sheet 33 of 41

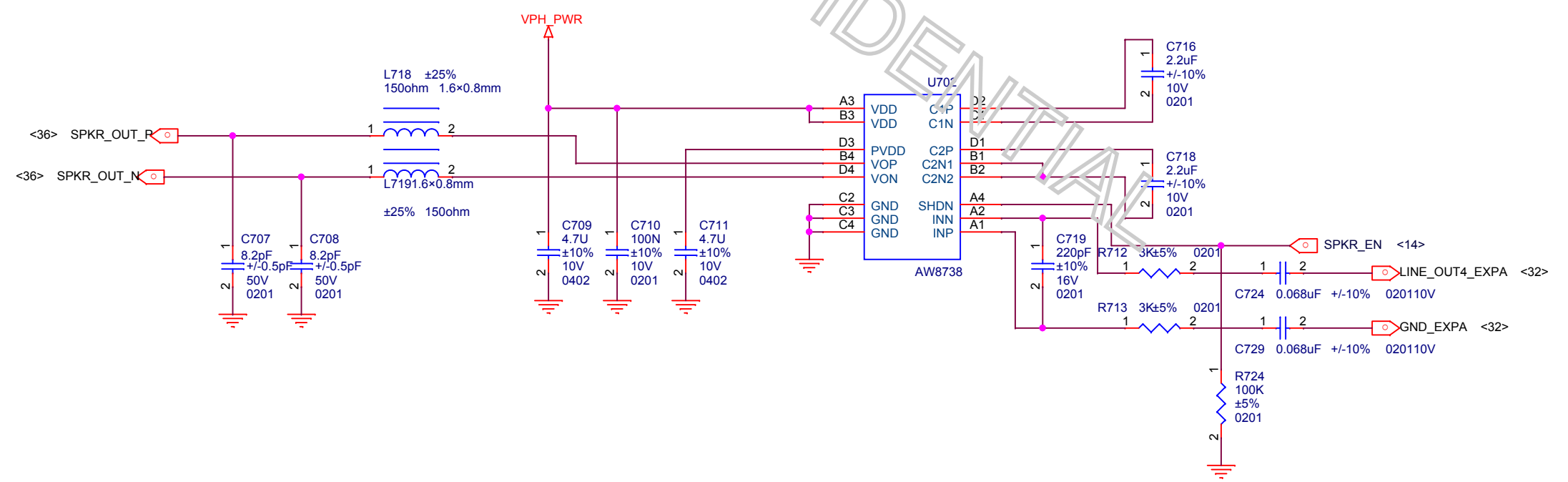
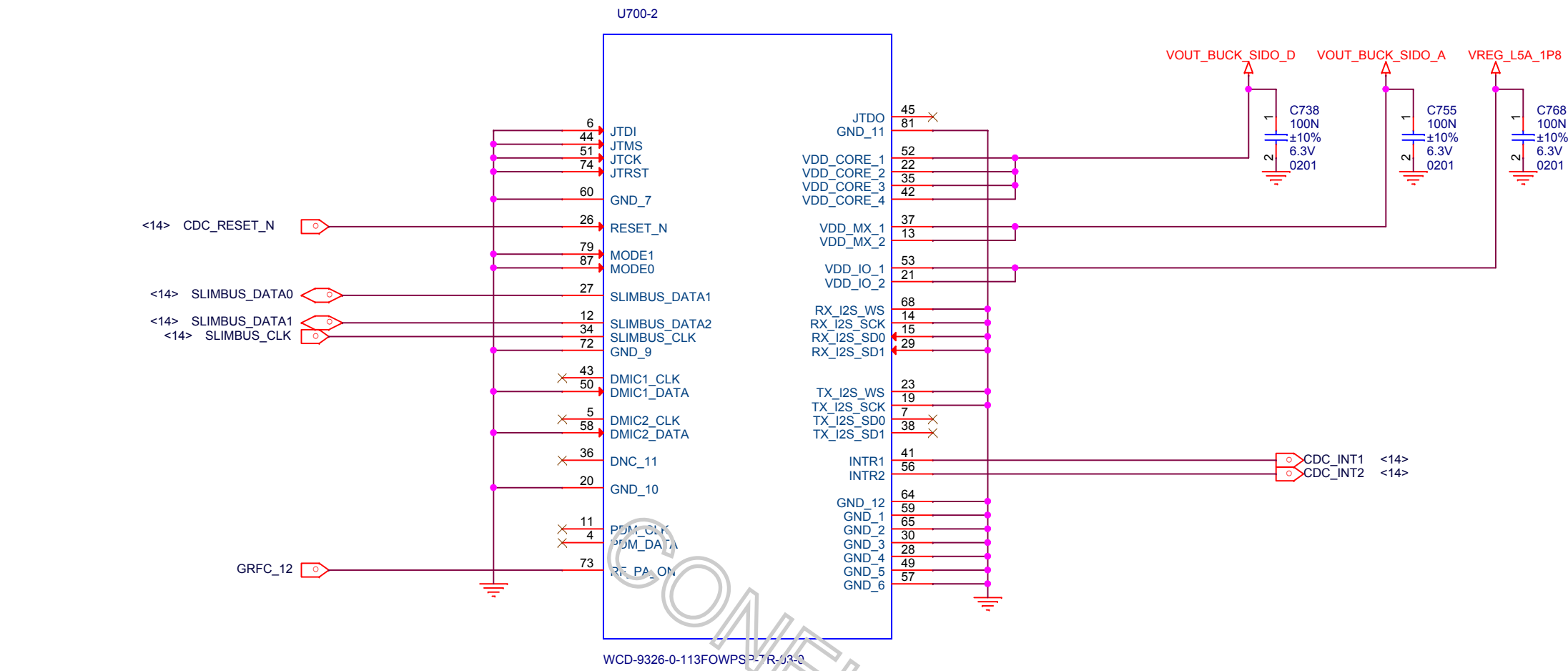

Receiver

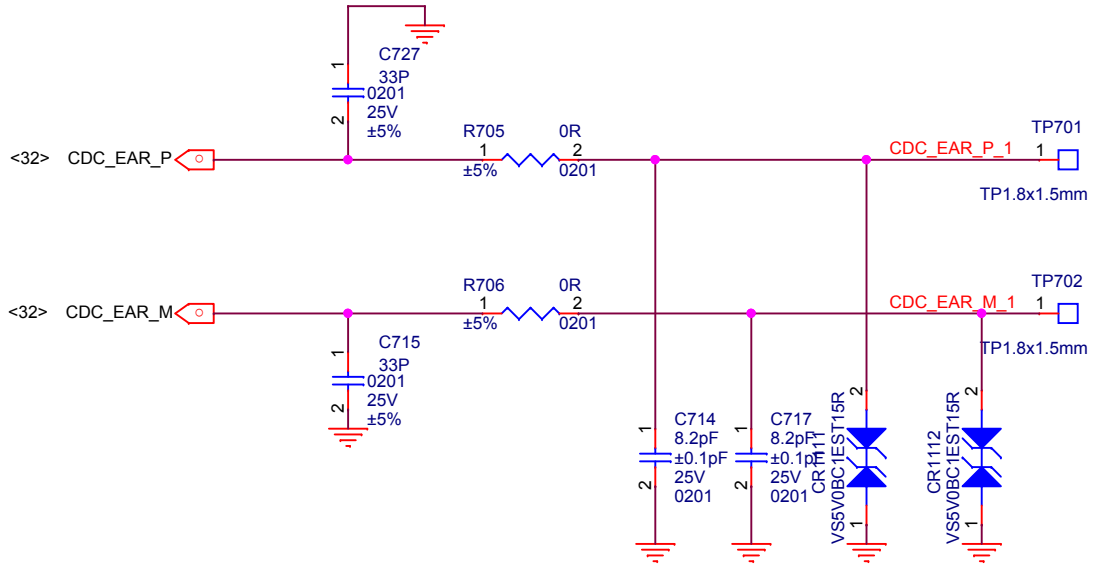

MIC3

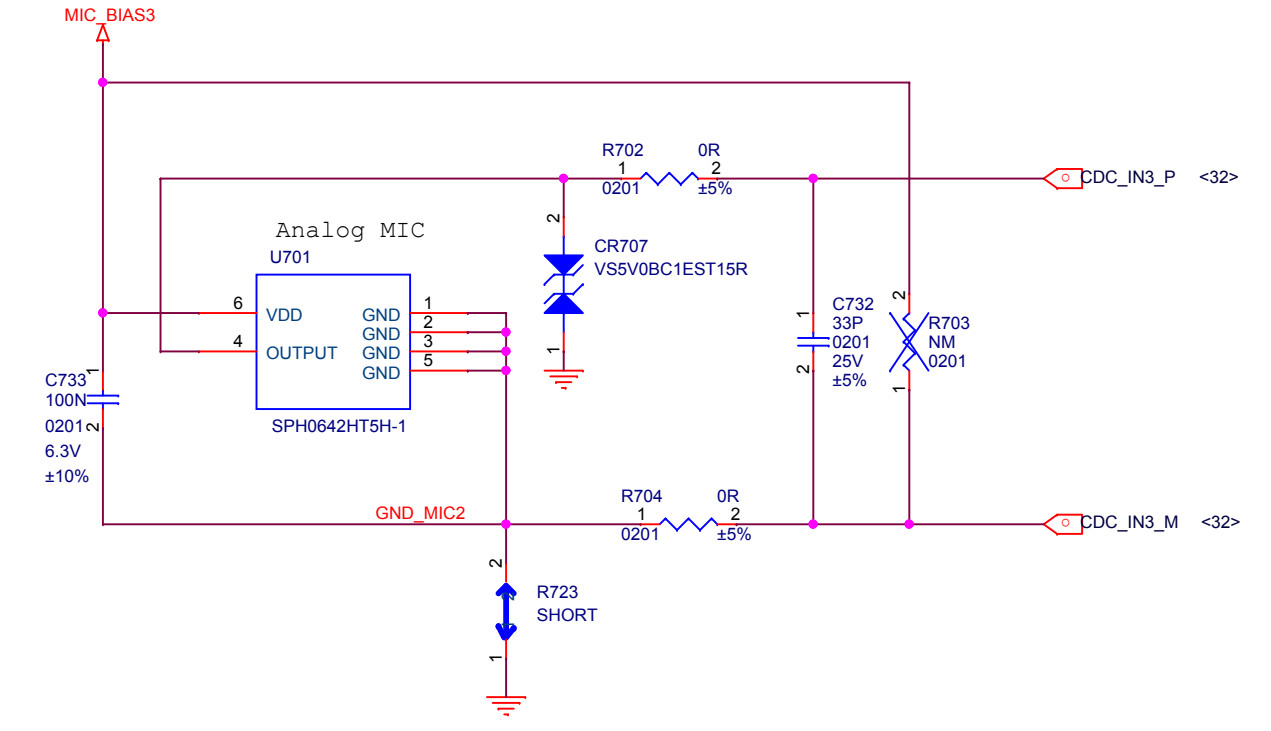

Earphone Audio

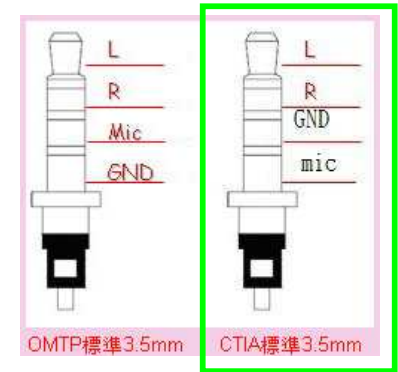
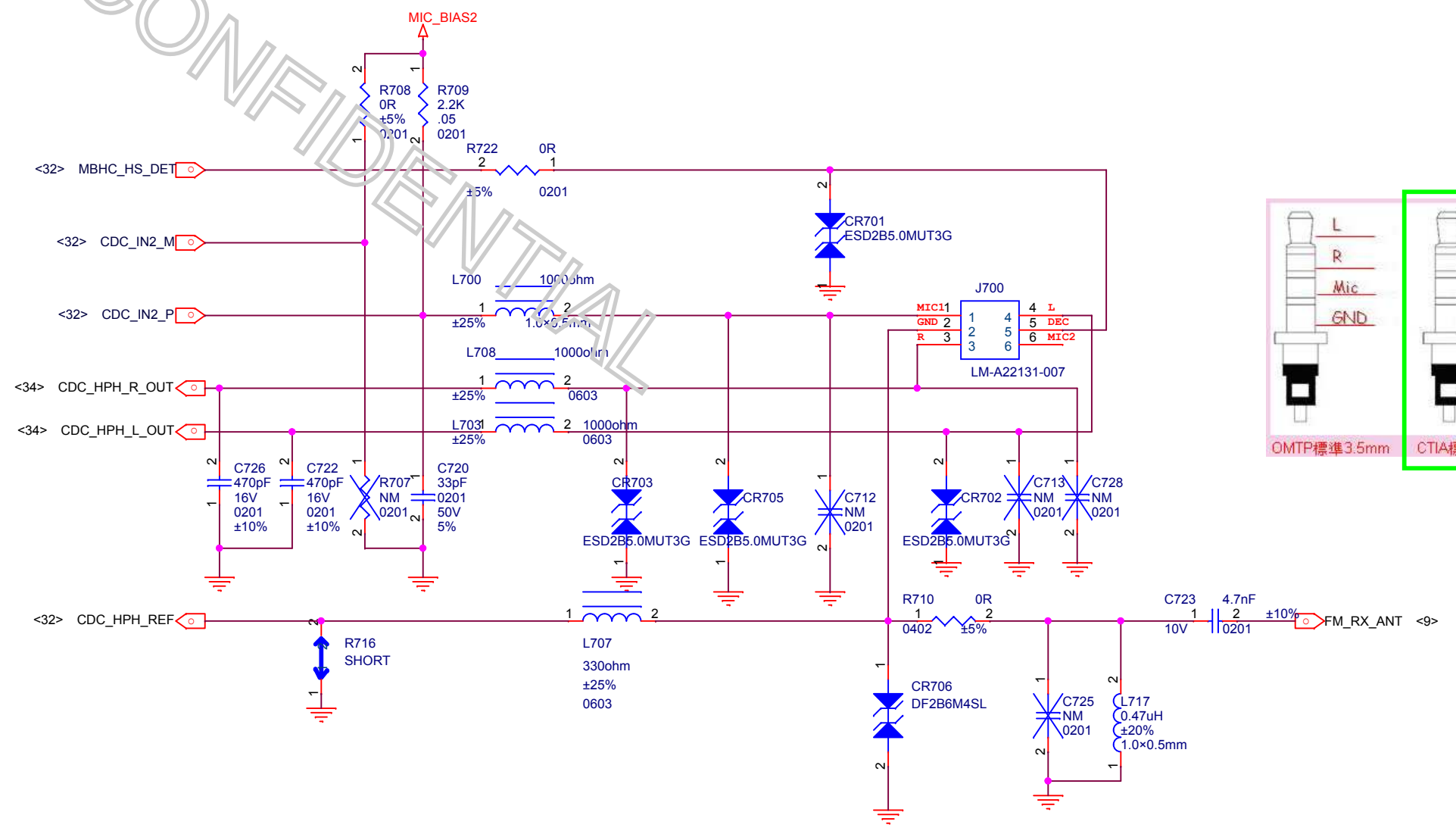
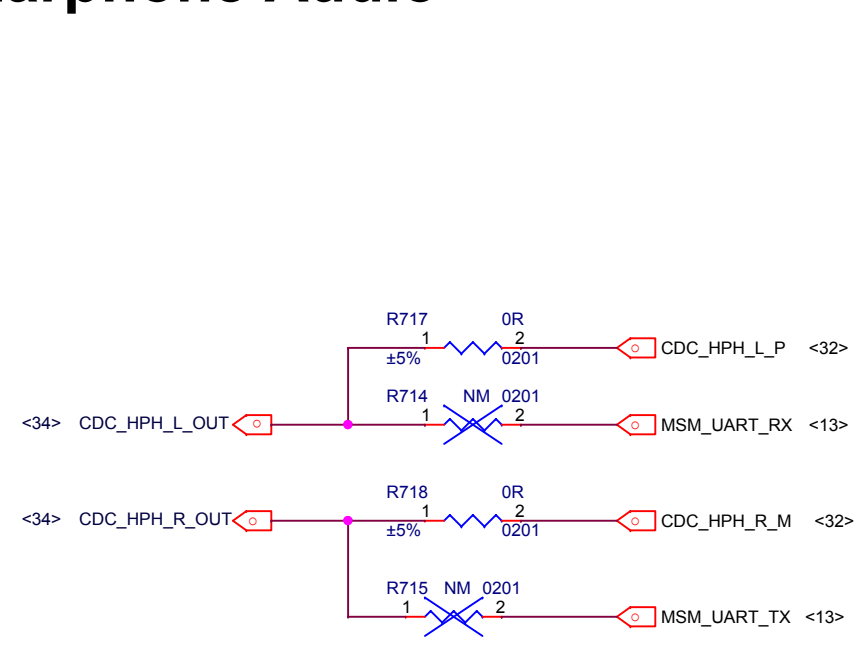

Title		
B3		
Size	Document Number	Rev
A3	<Doc>	P0
Date:	Thursday, February 25, 2016	Sheet 35 of 41

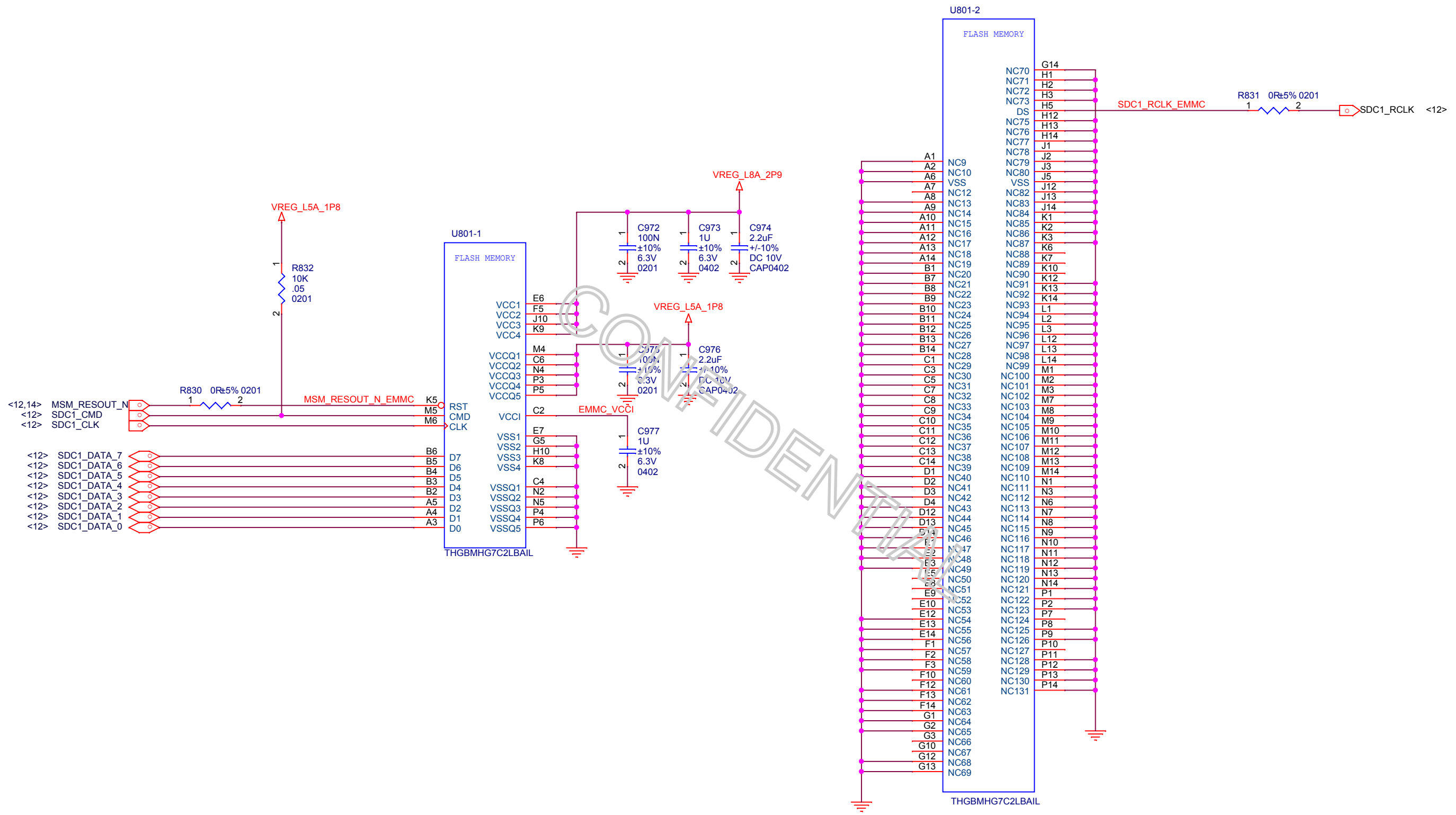

B2B

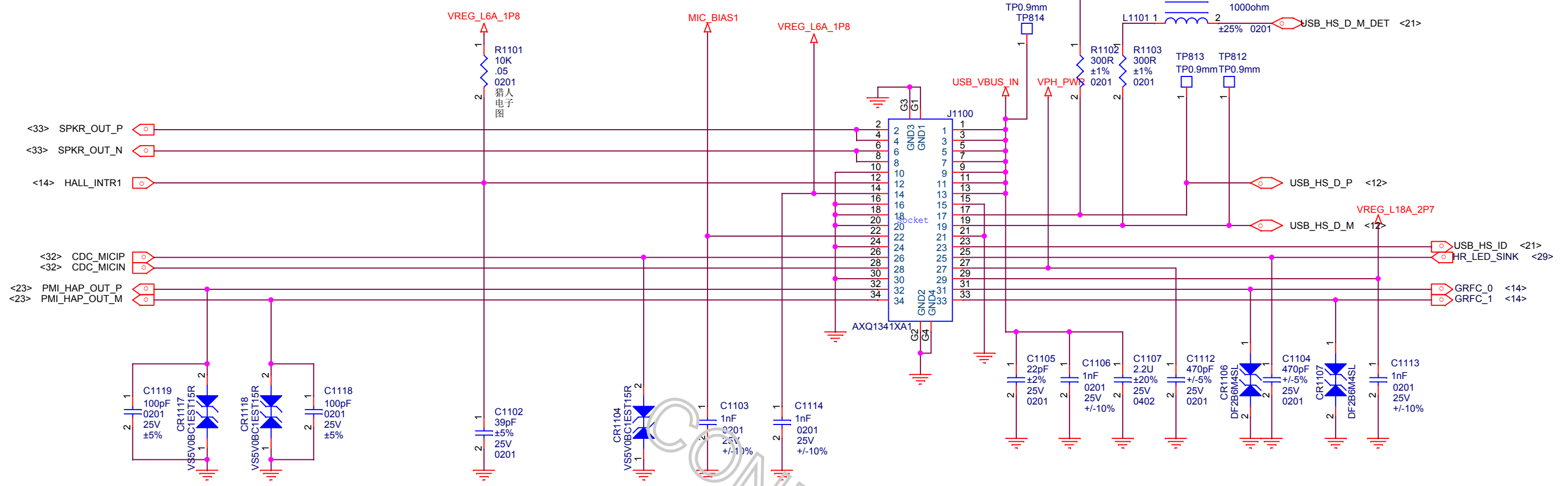

RECEIVER

SIDE KEY

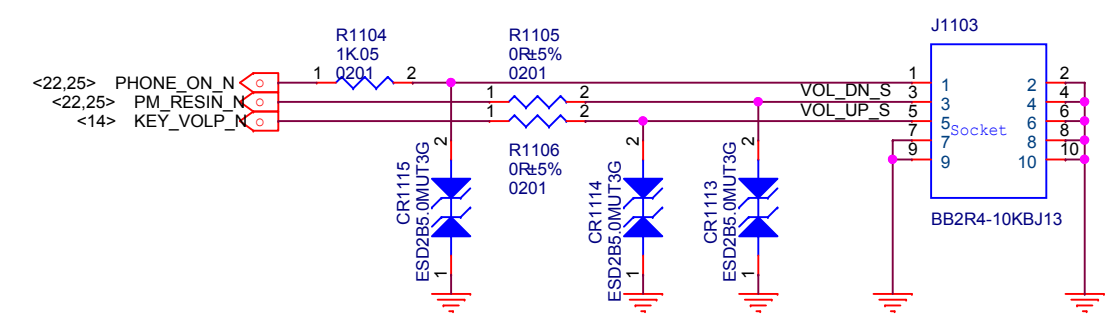

Title			B3
Size	Document Number	Rev	
A3	<Doc>	P0	
Date:	Monday, March 14, 2016	Sheet	37 of 41

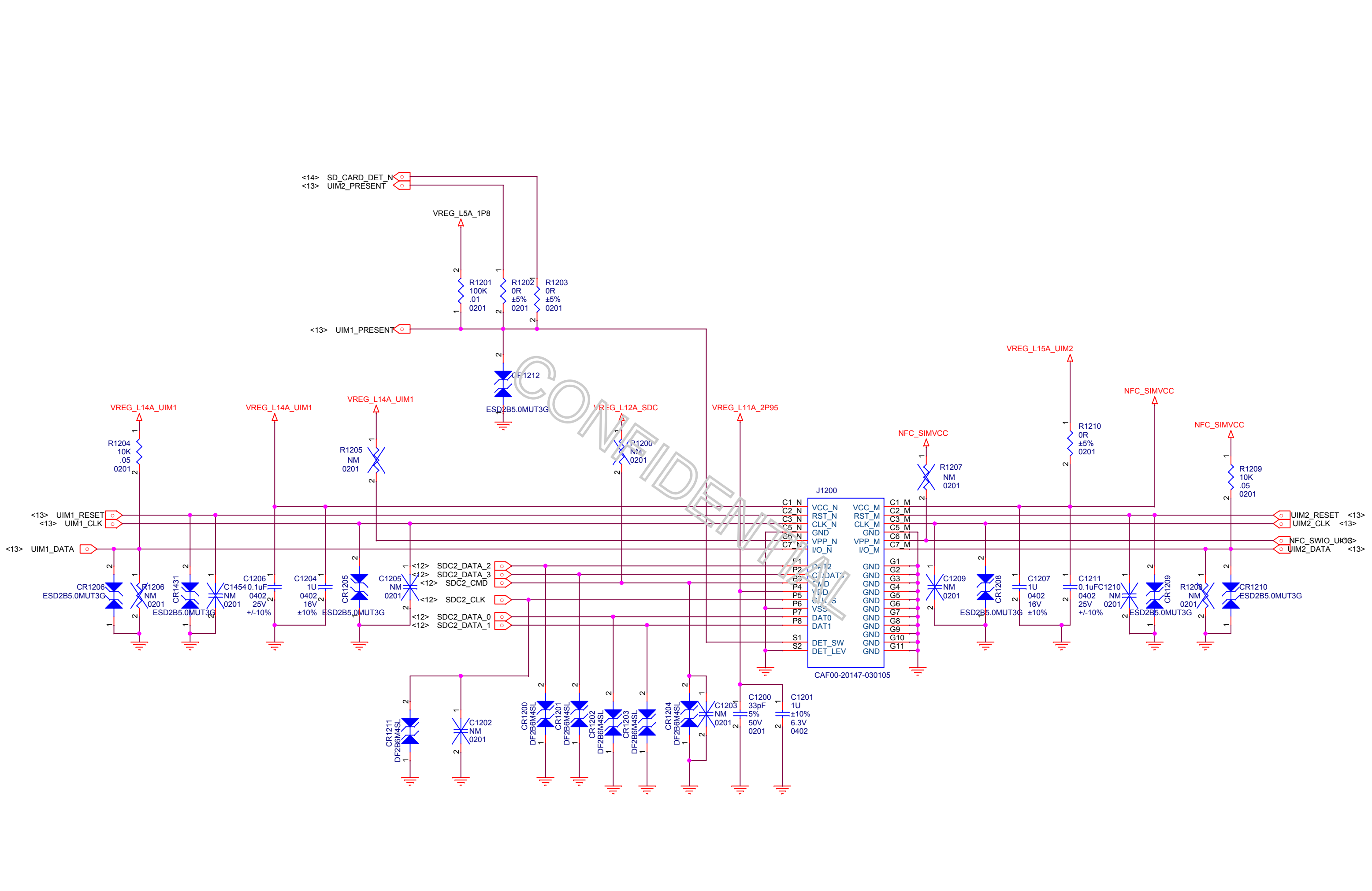

Title		B3
Size	Document Number	Rev
A3	<Doc>	P0
Date:	Thursday, January 21, 2016	Sheet 38 of 41

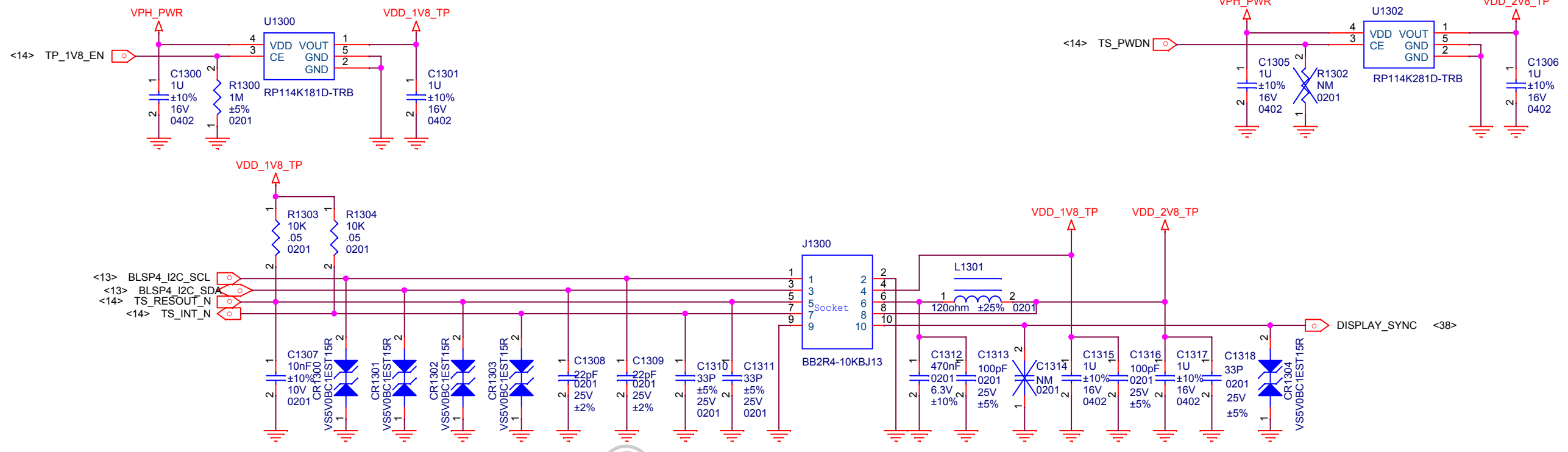

RGB

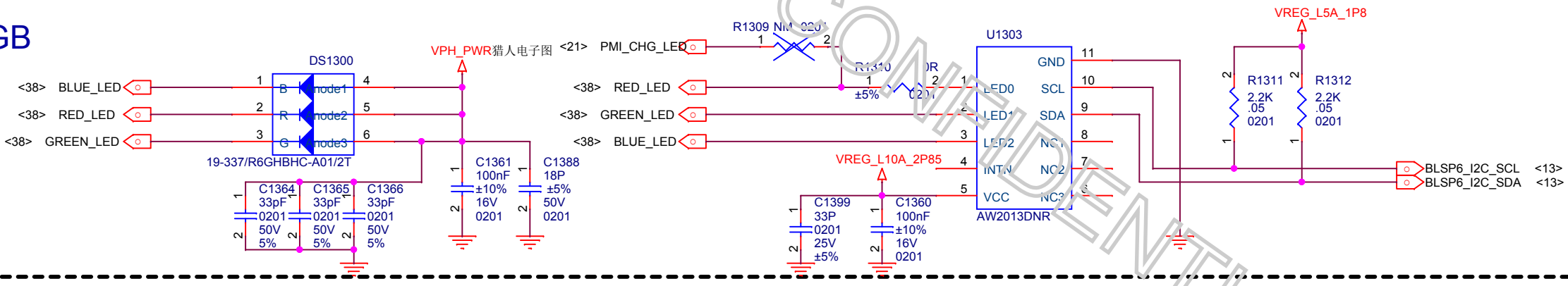

LCD

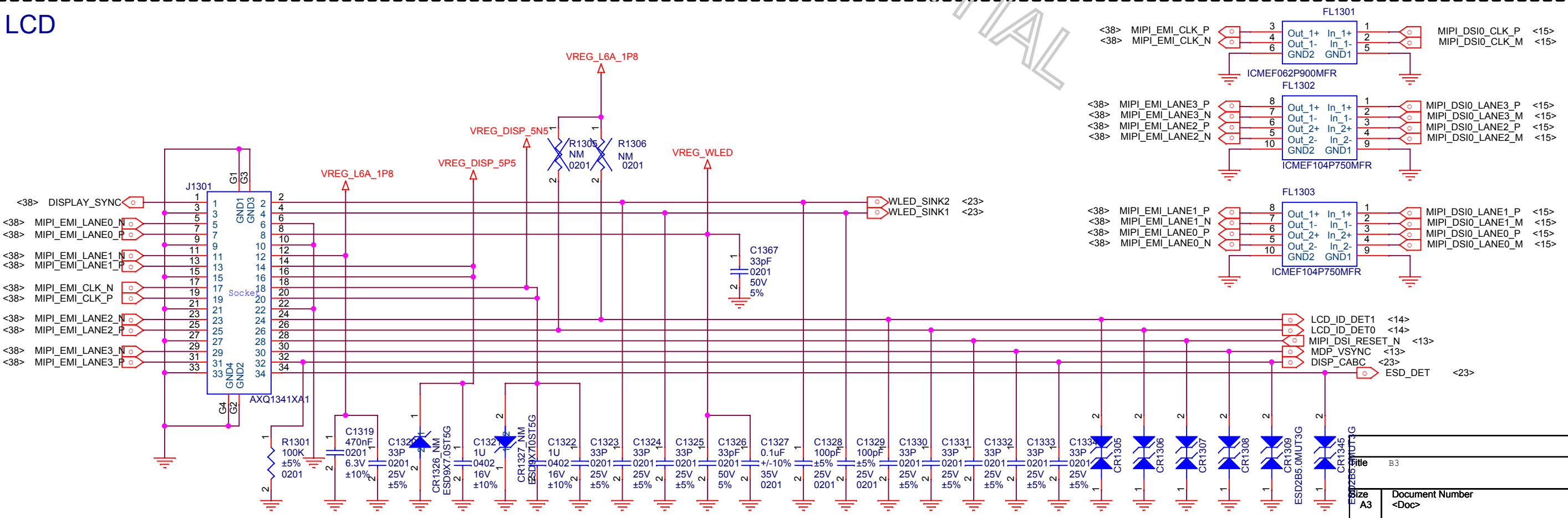

FlashLED

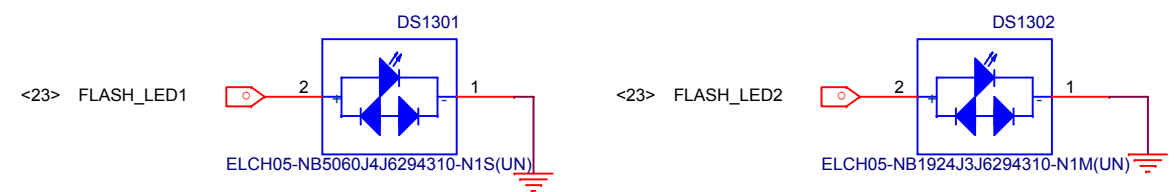

Rear Cam

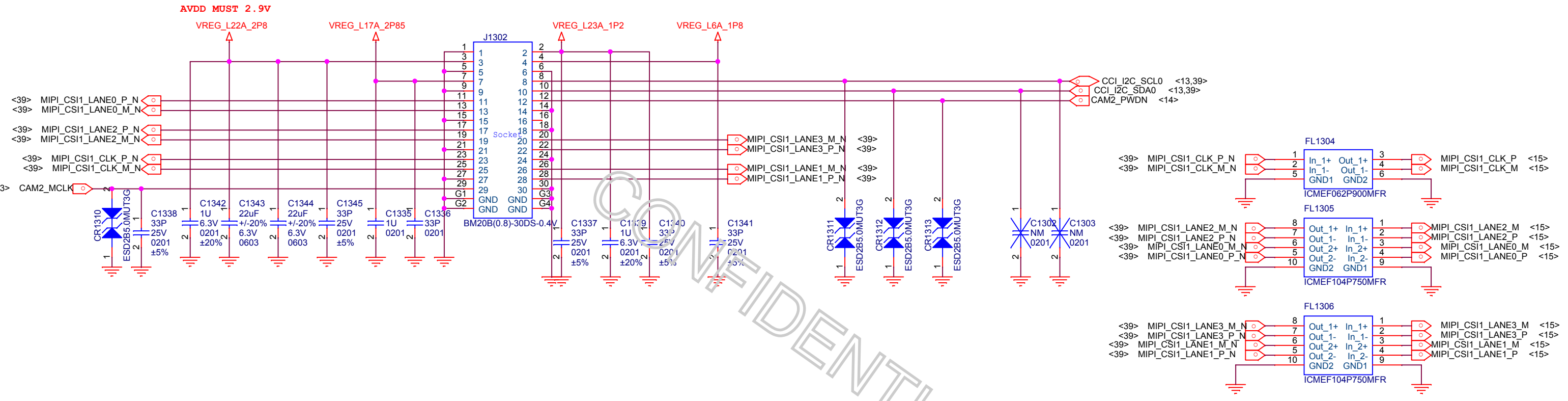

Front Cam

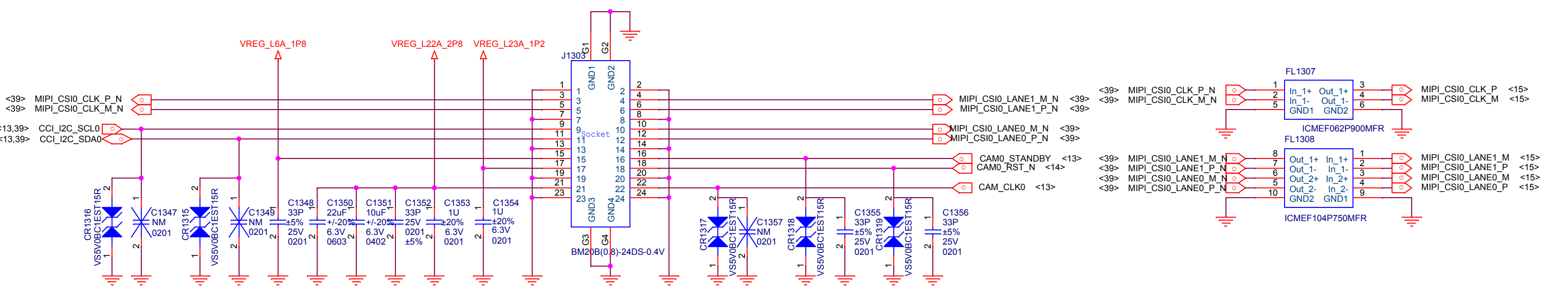

Title		B3
Size	Document Number	Rev P0
Date:	Monday, February 15, 2016	Sheet 40 of 41

G+G

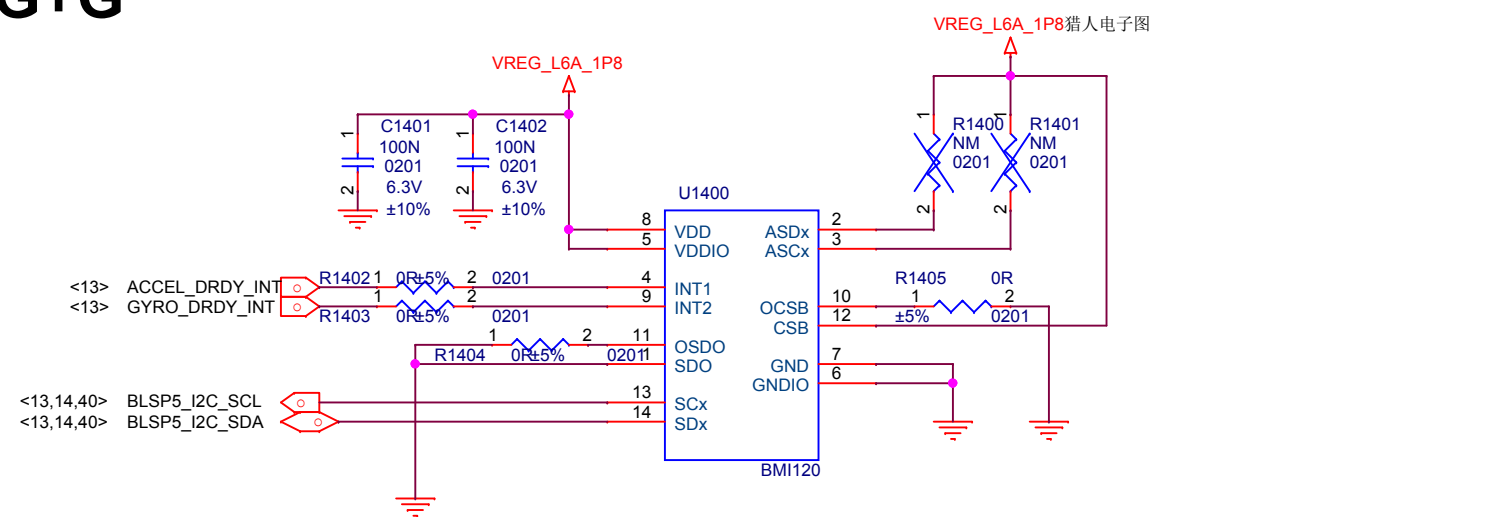

FP

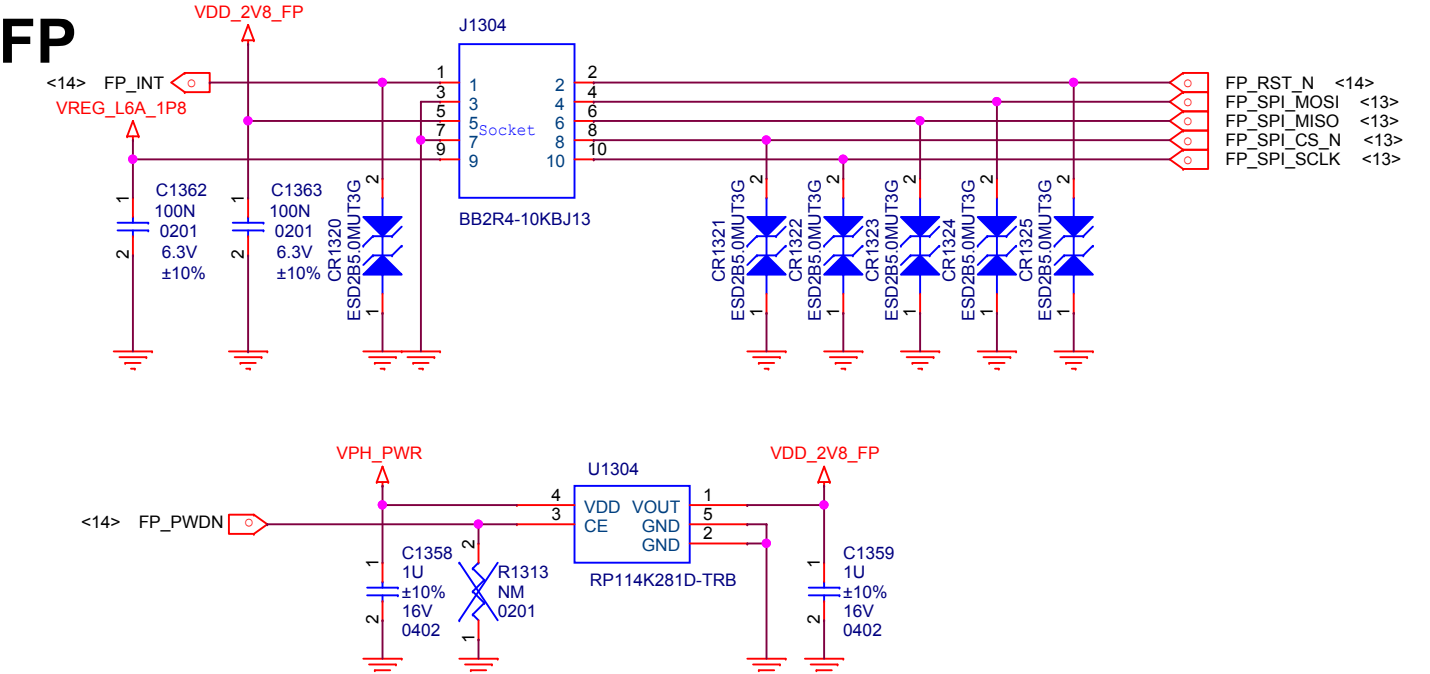

COMPASS

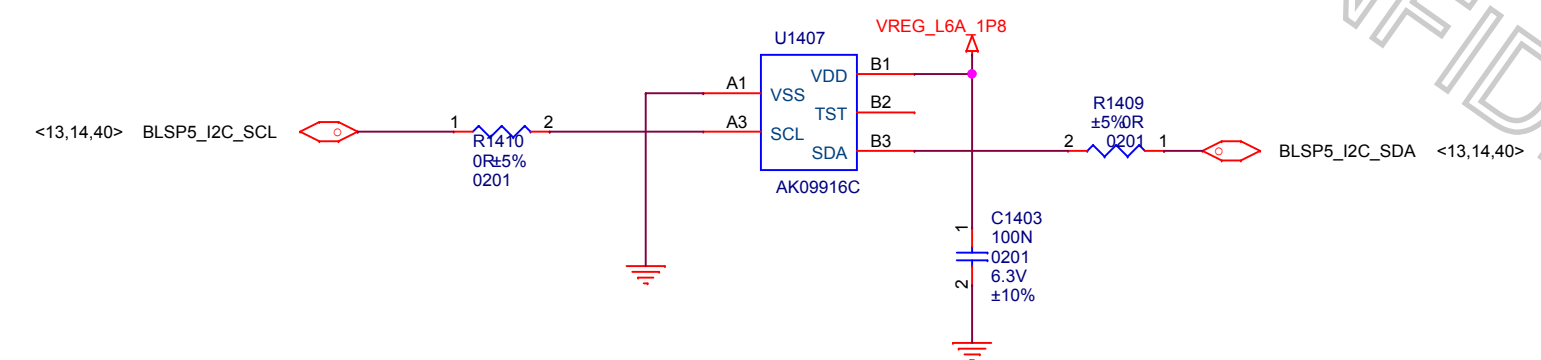

PSENSOR

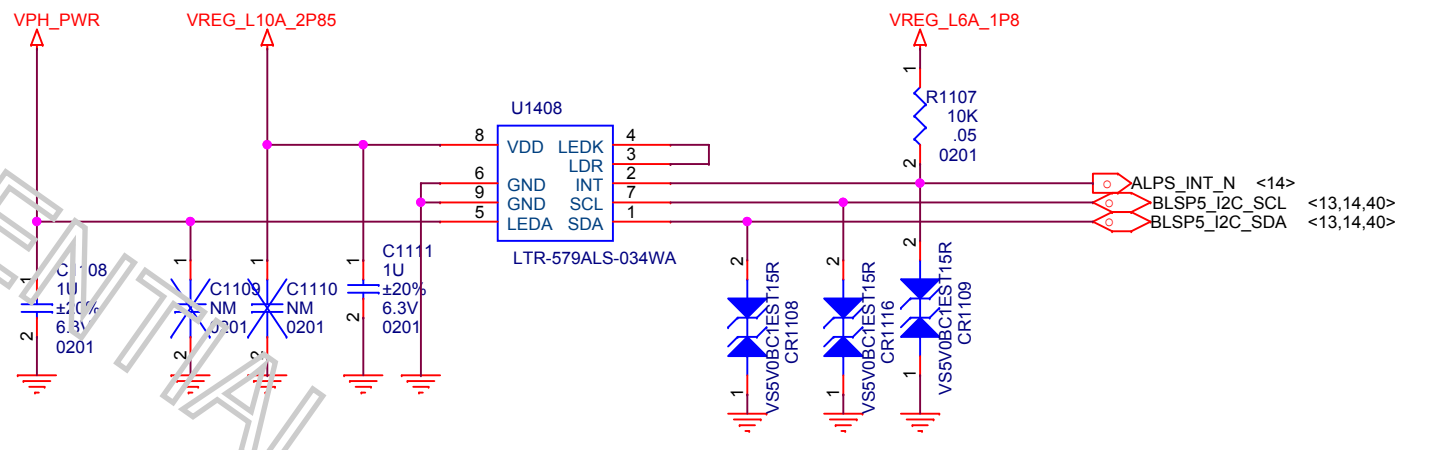

INFARED

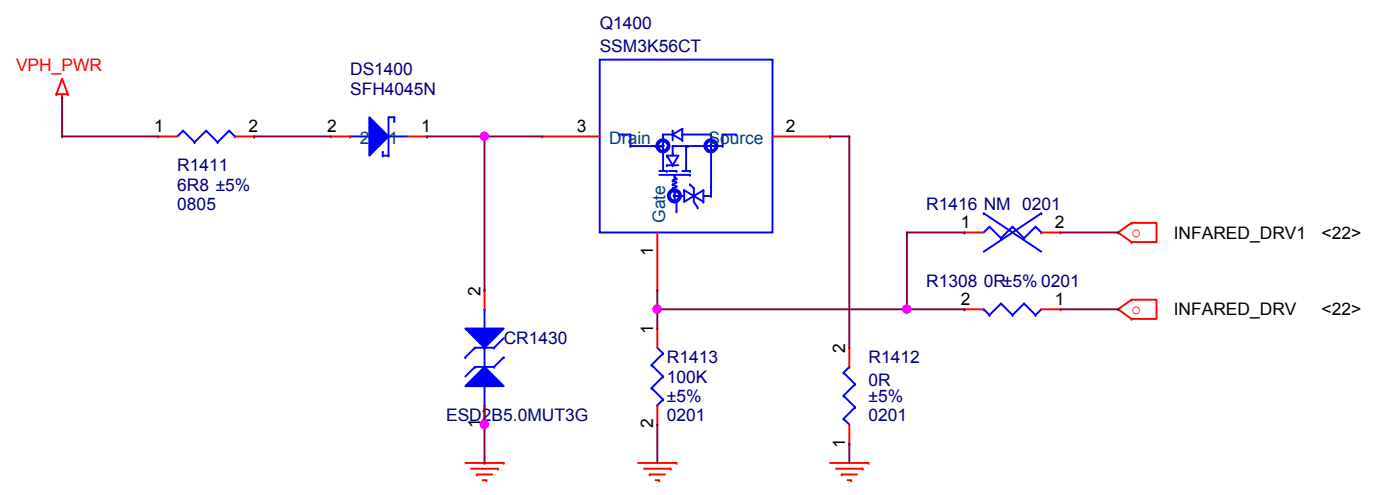

Title B3		
Size A3	Document Number	Rev P0
Date: Thursday, January 21, 2016	Sheet 41 of 41	