

REVISION RECORD			
LT#	ECO NO.	APPROVED	DATE

SDM660 GPIO Configuration For Starlord

GPIO_0	BLSPI_SPL_MOSI_1	GPIO_42	NC	GPIO_84	UIM2_CLK
GPIO_1	BLSPI_SPL_MISO_1	GPIO_43	NC	GPIO_85	UIM2_RESET
GPIO_2	BLSPI_SPL_CS1_N_1	GPIO_44	NC	GPIO_86	UIM2_PRESENT
GPIO_3	BLSPI_SPL_CLK_1	GPIO_45	NC	GPIO_87	UIM1_DATA
GPIO_4	BLSPI_UART_TX_2	GPIO_46	CAM0_RST_N	GPIO_88	UIM1_CLK
GPIO_5	BLSPI_UART_RX_2	GPIO_47	CAM1_RST_N	GPIO_89	UIM1_RESET
GPIO_6	BLSPI_I2C_SDA_2	GPIO_48	CAM2_RST_N	GPIO_90	UIM1_PRESENT
GPIO_7	BLSPI_I2C_SCL_2	GPIO_49	NC	GPIO_91	UIM_BATT_ALARM
GPIO_8	BLSPI_SPL_MOSI_3	GPIO_50	CAM_AVDD_EN	GPIO_92	GRFC_0
GPIO_9	BLSPI_SPL_MISO_3	GPIO_51	CAM_AVDD_EN	GPIO_93	NC
GPIO_10	BLSPI_SPL_CS_N_3	GPIO_52	NC	GPIO_94	NC
GPIO_11	BLSPI_SPL_CLK_3	GPIO_53	LCD0_RESET_N	GPIO_95	NC
GPIO_12	NC	GPIO_54	SD_CARD_DET_N	GPIO_96	WDOG_DISABLE
GPIO_13	NC	GPIO_55	DP_EN_N	GPIO_97	NC
GPIO_14	BLSPI_I2C_SDA_4	GPIO_56	USBC_ORIENTATION	GPIO_98	NC
GPIO_15	BLSPI_I2C_SCL_4	GPIO_57	FORCED_USB_BOOT	GPIO_99	QLINK_REQUEST
GPIO_16	BLSPI_UART_TX_5	GPIO_58	USB_PHY_PS	GPIO_100	QLINK_ENABLE
GPIO_17	BLSPI_UART_RX_5	GPIO_59	MDP_VSYNC_P	GPIO_101	RFFE1_DATA - WTR6955 debug
GPIO_18	BLSPI_UART_CTS_N_5	GPIO_60	NC	GPIO_102	RFFE1_CLK - WTR6955 debug
GPIO_19	BLSPI_UART_RFR_N_5	GPIO_61	NC	GPIO_103	RFFE2_DATA - (42)QFE2101 ch0, (43)QFE4360
GPIO_20	FP_SUB_RESET	GPIO_62	NC	GPIO_104	RFFE2_CLK - (42)QFE2101 ch0, (43)QFE4360
GPIO_21	SMB_STAT	GPIO_63	NC	GPIO_105	NC
GPIO_22	BLSPI_I2C_SDA_6	GPIO_64	NC	GPIO_106	NC
GPIO_23	BLSPI_I2C_SCL_6	GPIO_65	NC	GPIO_107	RFFE4_DATA - (53)QAT3514, (53)QAT3550
GPIO_24	NC	GPIO_66	TS_RESET_N	GPIO_108	RFFE4_CLK - (53)QAT3514, (53)QAT3550
GPIO_25	NC	GPIO_67	TS_INT_N	GPIO_109	RFFE5_DATA
GPIO_26	WSA_SPKR_SD_N_1	GPIO_68	ACC_GYRO_DATA_AVA_INT_N	GPIO_110	RFFE5_CLK
GPIO_27	WSA_SPKR_SD_N_2	GPIO_69	ACC_GYRO_MOT_INT_N	GPIO_111	RFFE6_DATA
GPIO_28	NFC_IRQ	GPIO_70	MAG_INT_N	GPIO_112	RFFE6_CLK
GPIO_29	NFC_EN	GPIO_71	ALSP_INT_N	GPIO_113	NC
GPIO_30	NFC_DWL_REQ	GPIO_72	FP_INT_N_1	SSC_0	LPL_SPL_1_CS1_N
GPIO_31	NFC_ESE_PWR_REQ	GPIO_73	NC	SSC_1	LPL_PWR_EN
GPIO_32	CAM_MCLK0	GPIO_74	NC	SSC_2	LPL_I2C_3_SDA
GPIO_33	CAM_MCLK1	GPIO_75	NC	SSC_3	LPL_I2C_3_SCL
GPIO_34	CAM_MCLK2	GPIO_76	NC	SSC_4	LPL_SPL_2_CS_N
GPIO_35		GPIO_77	AUDIO_USBC_EN2_N	SSC_5	LPL_SPL_2_CLK
GPIO_36	CCI_I2C_SDA0	GPIO_78	WMSS_RESETN	SSC_6	LPL_SPL_2_MOSI
GPIO_37	CCI_I2C_SCL0	GPIO_79	PWM_CNTRL	SSC_7	LPL_SPL_2_MISO
GPIO_38	CCI_I2C_SDA1	GPIO_80	AUDIO_USBC_EN1	SSC_8	LPL_SPL_1_CS_N
GPIO_39	CCI_I2C_SCL1	GPIO_81	MSS_LTE_COXM_TXD	SSC_9	LPL_SPL_1_CS_N
GPIO_40	NC	GPIO_82	MSS_LTE_COXM_RXD	SSC_10	LPL_SPL_1_MOSI
GPIO_41	FL_STROBE_TRIG	GPIO_83	UIM2_DATA	SSC_11	LPL_SPL_1_MISO

SSC_12	LPL_UART_1_TX
SSC_13	LPL_UART_1_RX
SSC_14	NC
SSC_15	NC
SSC_16	NC
SSC_17	NC
SSC_18	WCD_SDM_MCLK
SSC_19	LPL_AUD_SB_CLK
SSC_20	LPL_AUD_SB_DATA0
SSC_21	LPL_AUD_SB_DATA1
SSC_22	LPL_AUD_CDC_INT1
SSC_23	LPL_AUD_CDC_INT2
SSC_24	LPL_AUD_CDC_RSTN
SSC_25	NC
SSC_26	NC
SSC_27	NC
SSC_29	NC
SSC_30	LPL_QCA_SB_CLK
SSC_31	LPL_QCA_SB_DATA0

GROOT GPIO Configuration For Starlord

GPIO_1	OPTION1	GPIO_8	SLB
GPIO_2	DIV_CLK2	GPIO_9	uUSB_TYPEC
GPIO_3	DIV_CLK1	GPIO_10	WCSS_VCTRL
GPIO_4	NFC_CLK_REQ	GPIO_11	HOMEKEY_FP_PM_INT
GPIO_5	WLAN_SW_CTRL	GPIO_12	WIPWR_MODE
GPIO_6	SLP_CLK	GPIO_13	PM_A_GPIO_13
GPIO_7	UIM_BATT_ALARM		

DRAX GPIO Configuration For Starlord

GPIO_1	OPTION2	GPIO_8	SD_CARD_DET_N
GPIO_2	LPL_PWR_EN	GPIO_9	WCSS_VCTRL
GPIO_3	FRONT_CAM_DVDD_EN	GPIO_10	SLB
GPIO_4	REAR_CAM_DVDD_EN	GPIO_11	LP4x_CTRL
GPIO_5	NC	GPIO_12	LP4x_MODE
GPIO_6	FP_VDD_EN		
GPIO_7	KEY_VOL_UP_N		

COMPANY: <Company Name>

TITLE: <Title>

DRAWN: <Drawn By>	DATE: <Drawn Date>	CODR:	SIZE:	DRAWING NO:	REV:
CHECKED: <Checked By>	DATE: <Checked Date>				
QUALITY CONTROL: <QC By>	DATE: <QC Date>	<Code>	A0	<Drawing Number>	<Revision>
RELEASED: <Released By>	DATE: <Release Date>	SCALE: <Scale>		SHEET 13	21

REVISION RECORD			
LT#	ECO NO.	APPROVER	DATE

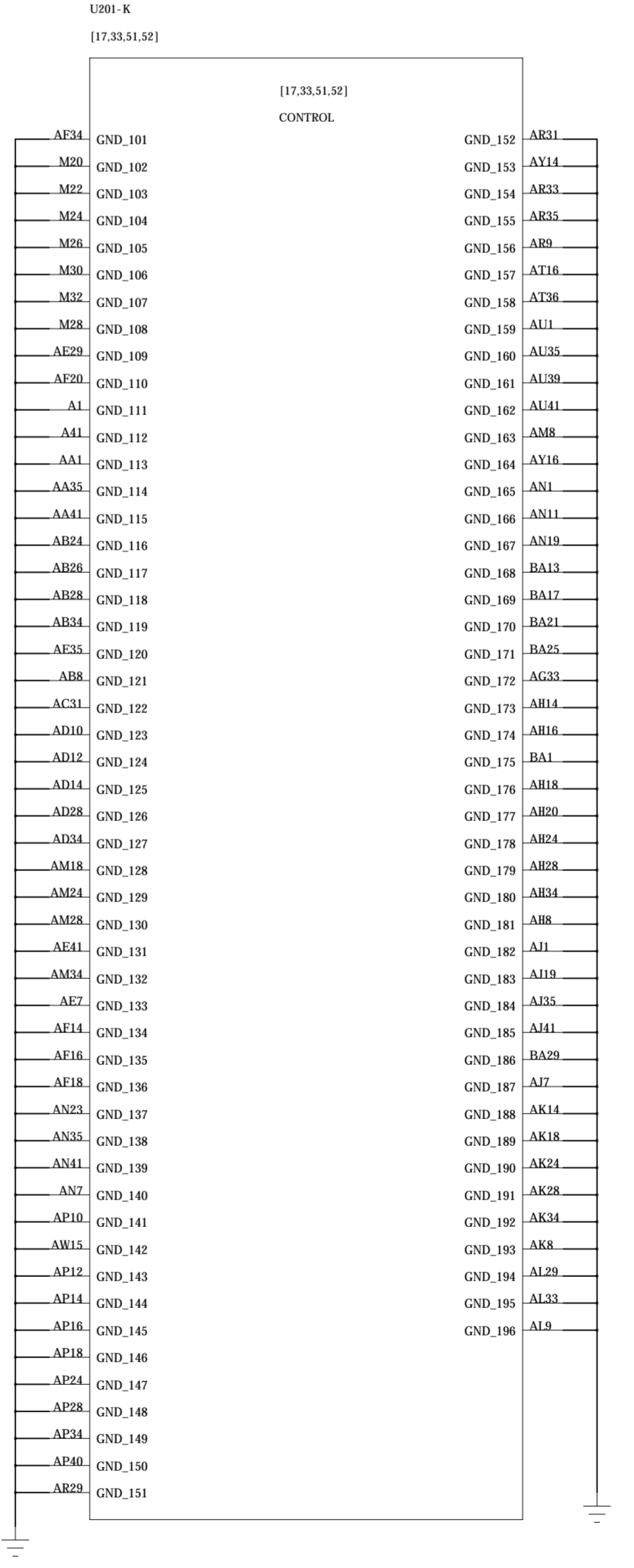
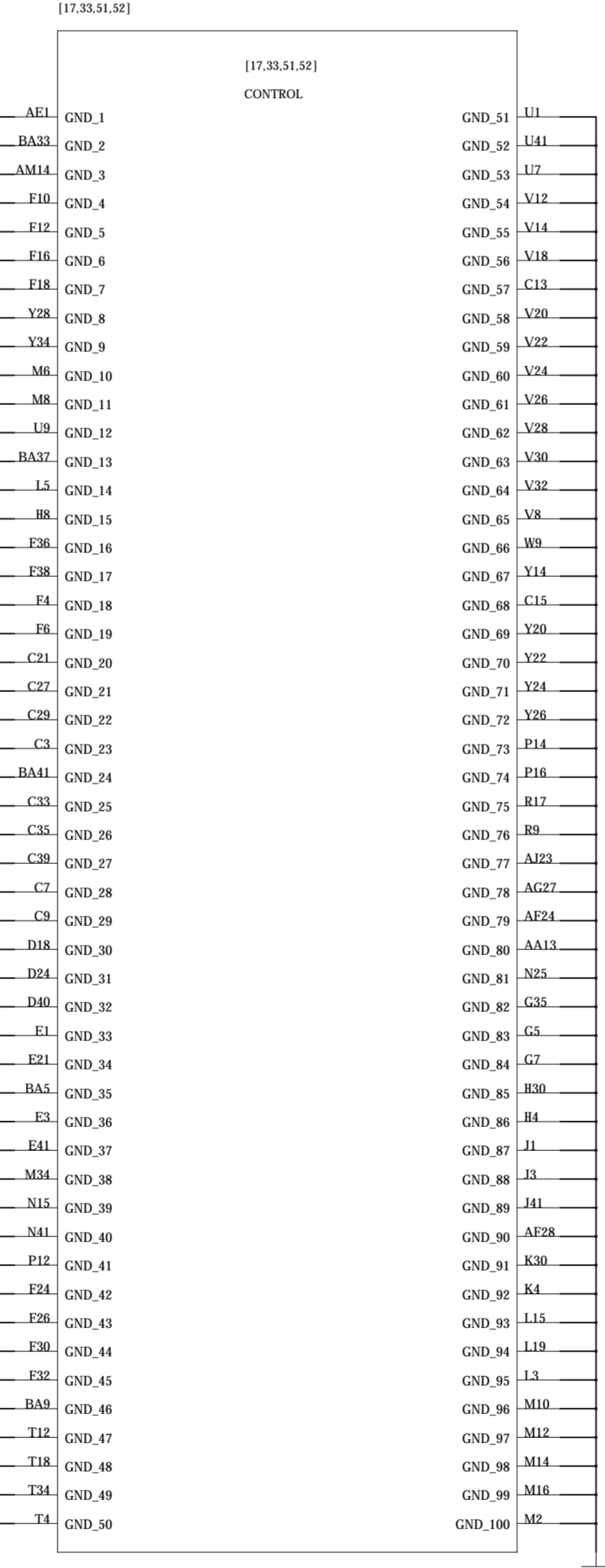
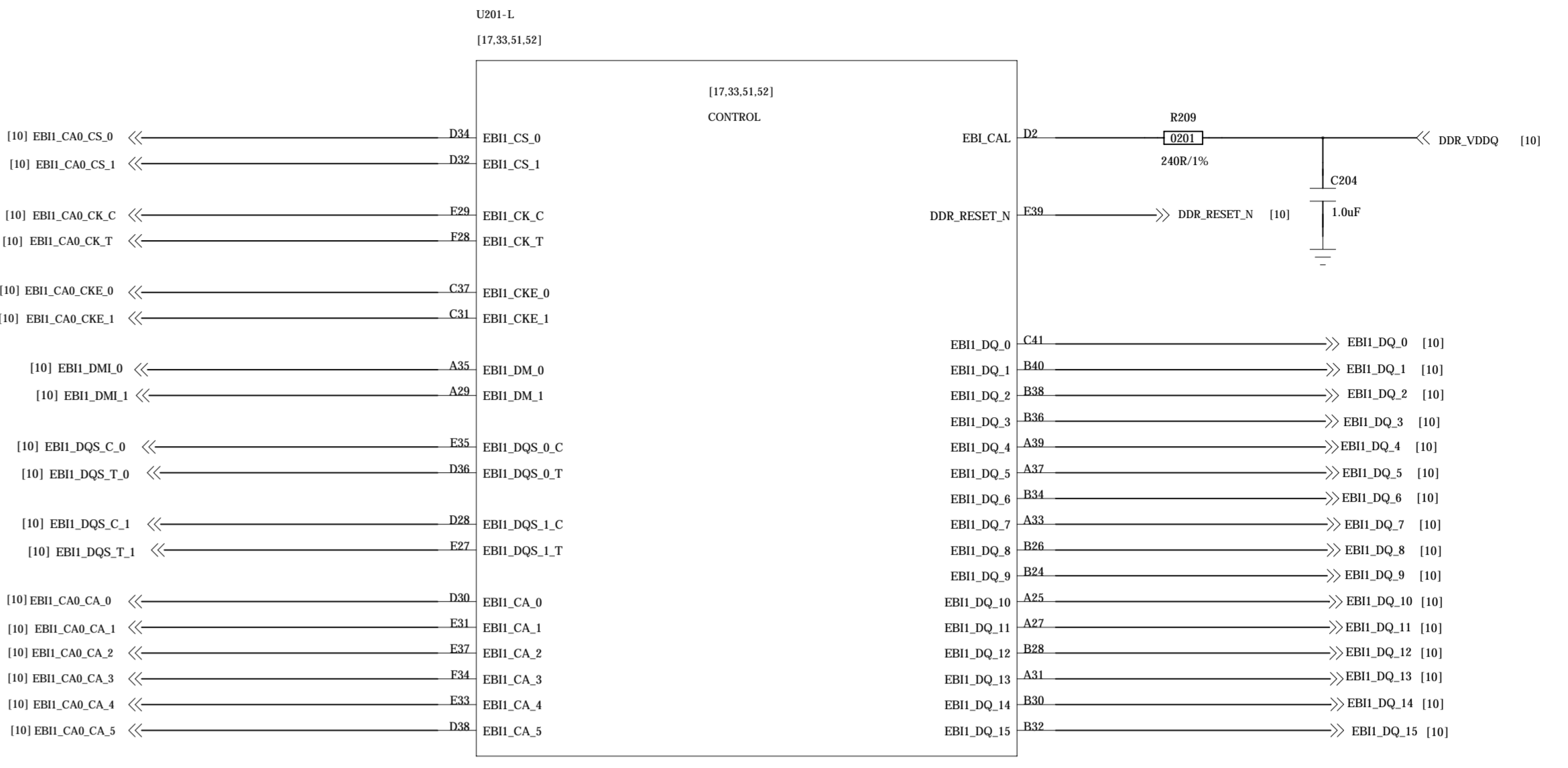
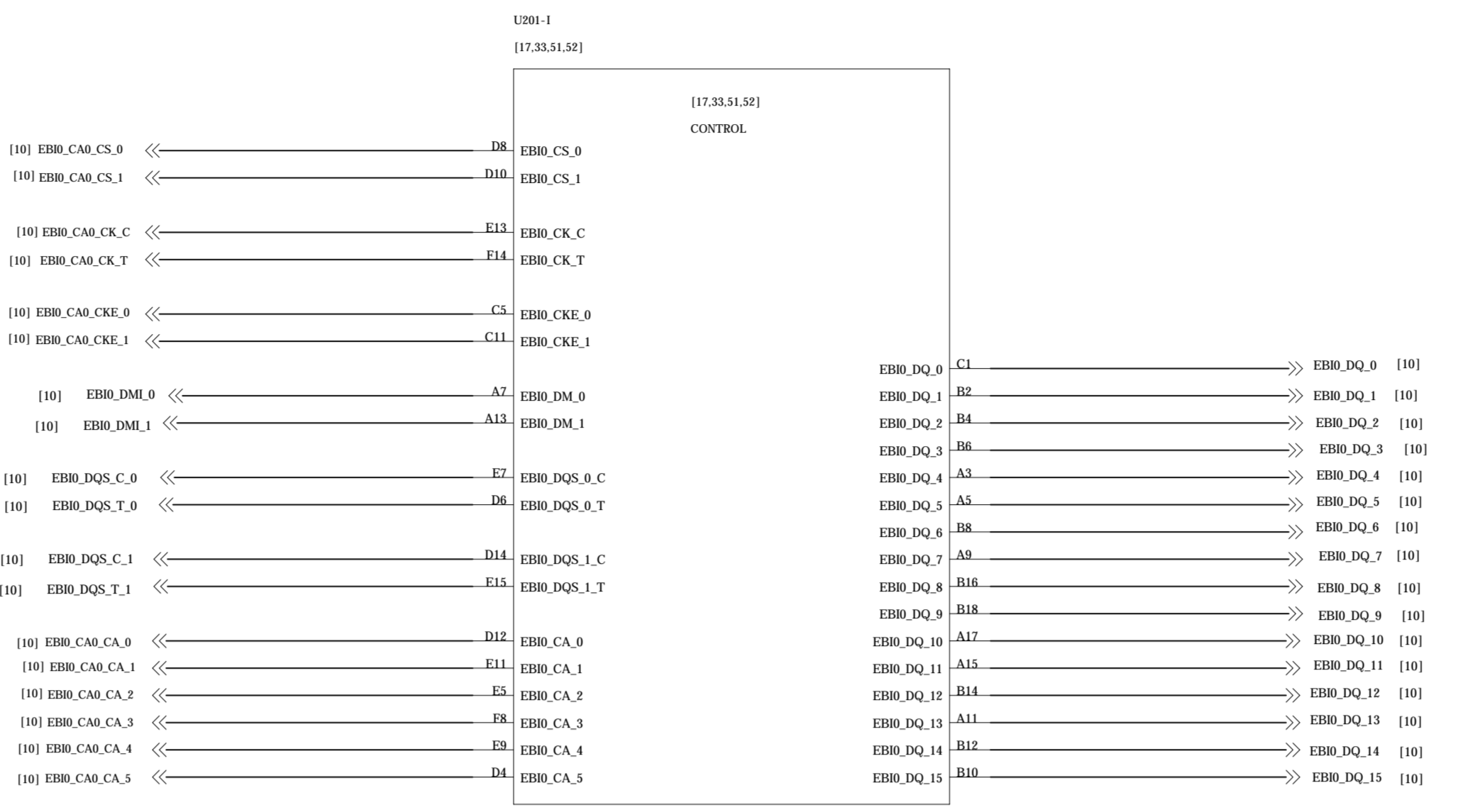
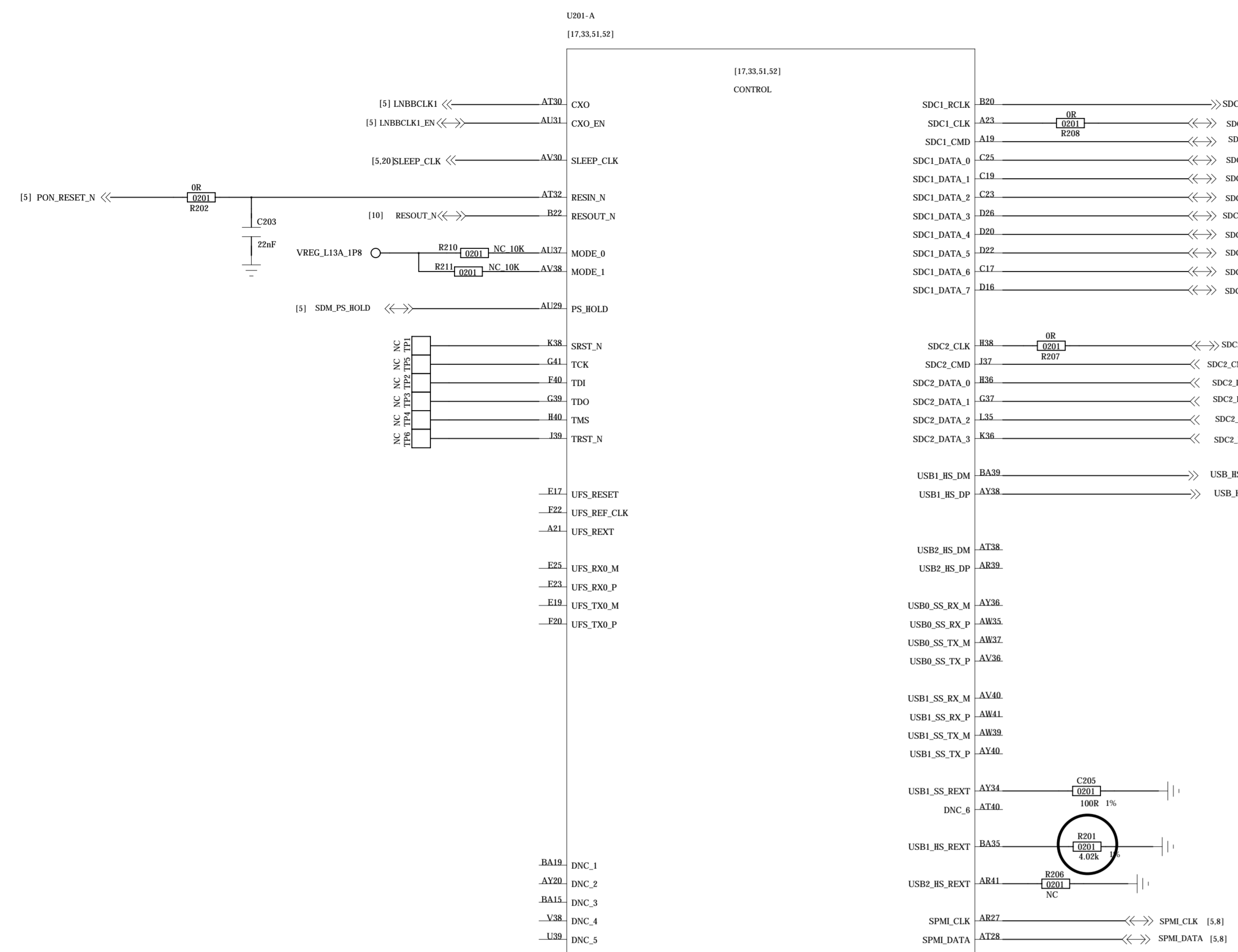

COMPANY: <Company Name>				
TITLE: <Title>				
DRAWN: <Drawn By>	DATE: <Drawn Date>	CODE: <Code>	SIZE: A0	DRAWING NO: <Drawing Number><Revision>
CHECKED: <Checked By>	DATE: <Checked Date>	SCALE: <Scale>	SHEET: 2 of 21	REV: <Revision>
QUALITY CONTROL: <QC By>	DATE: <QC Date>	RELEASED: <Released By>		

REVISION RECORD			
LTW	ECO NO.	APPROVED	DATE

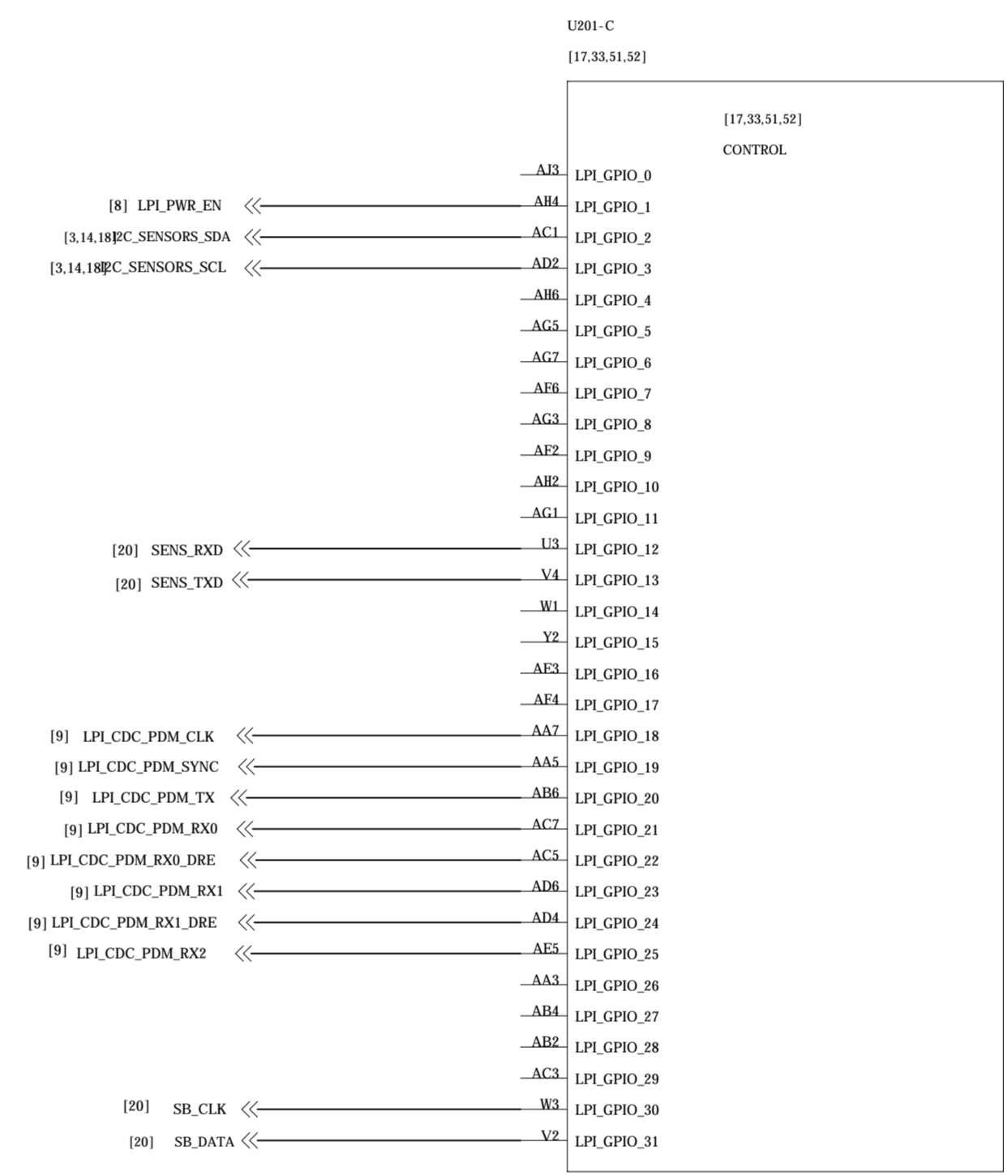
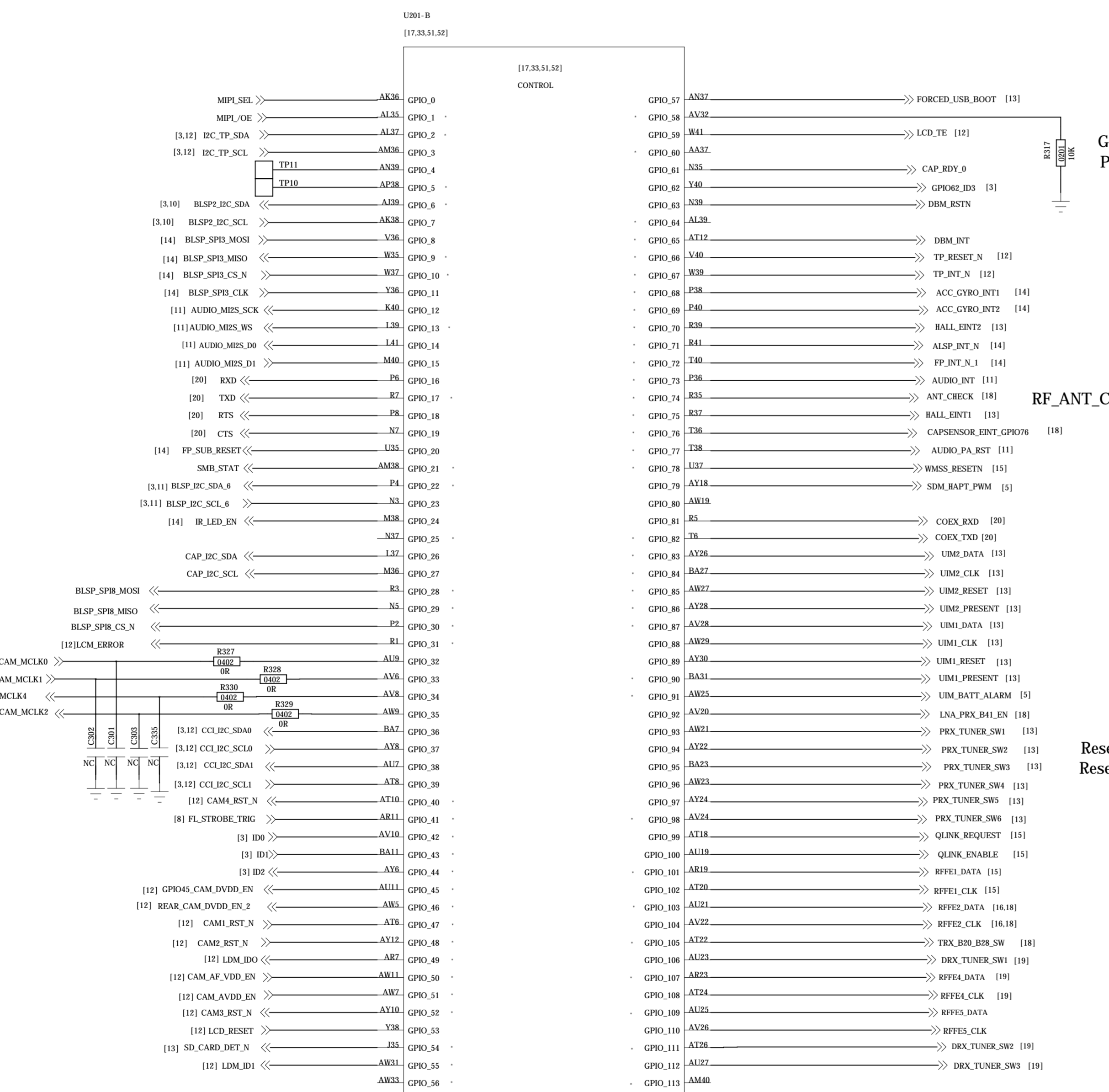
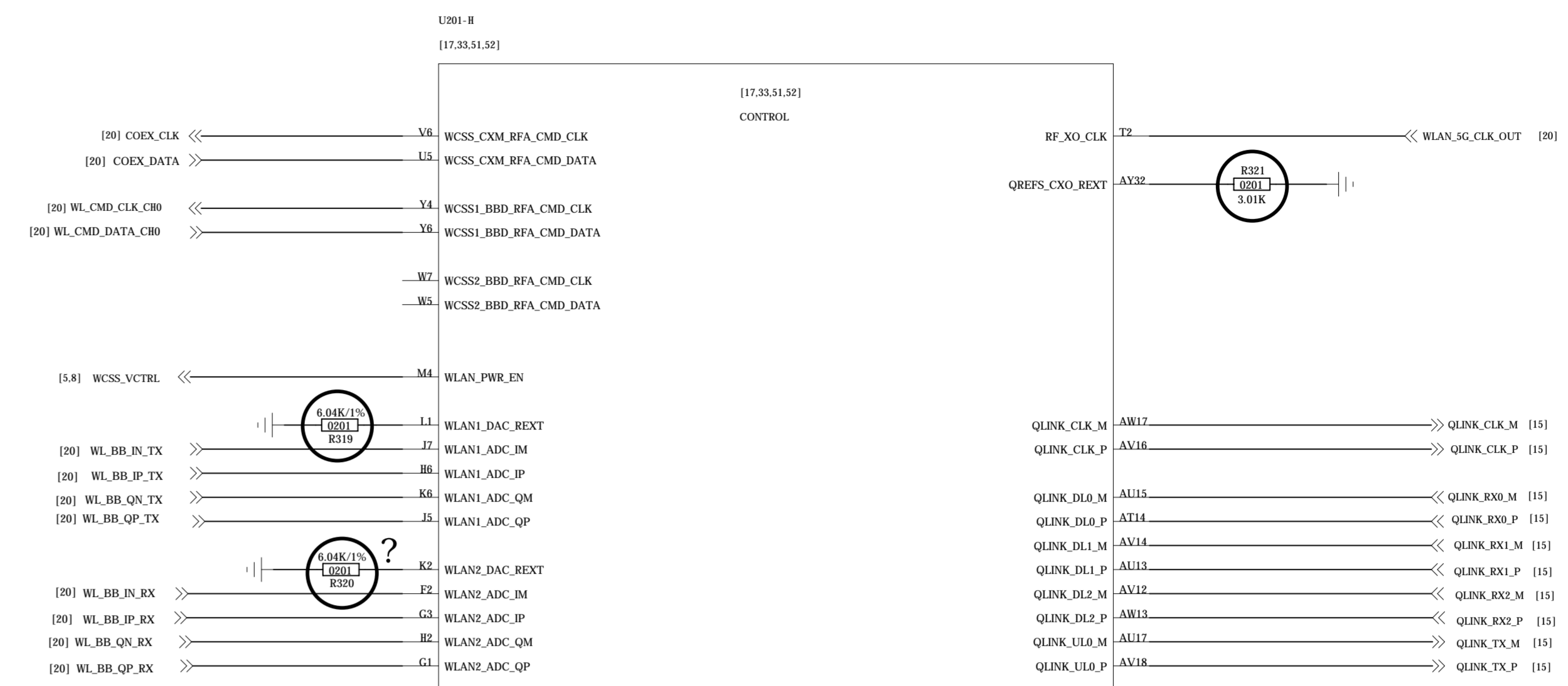
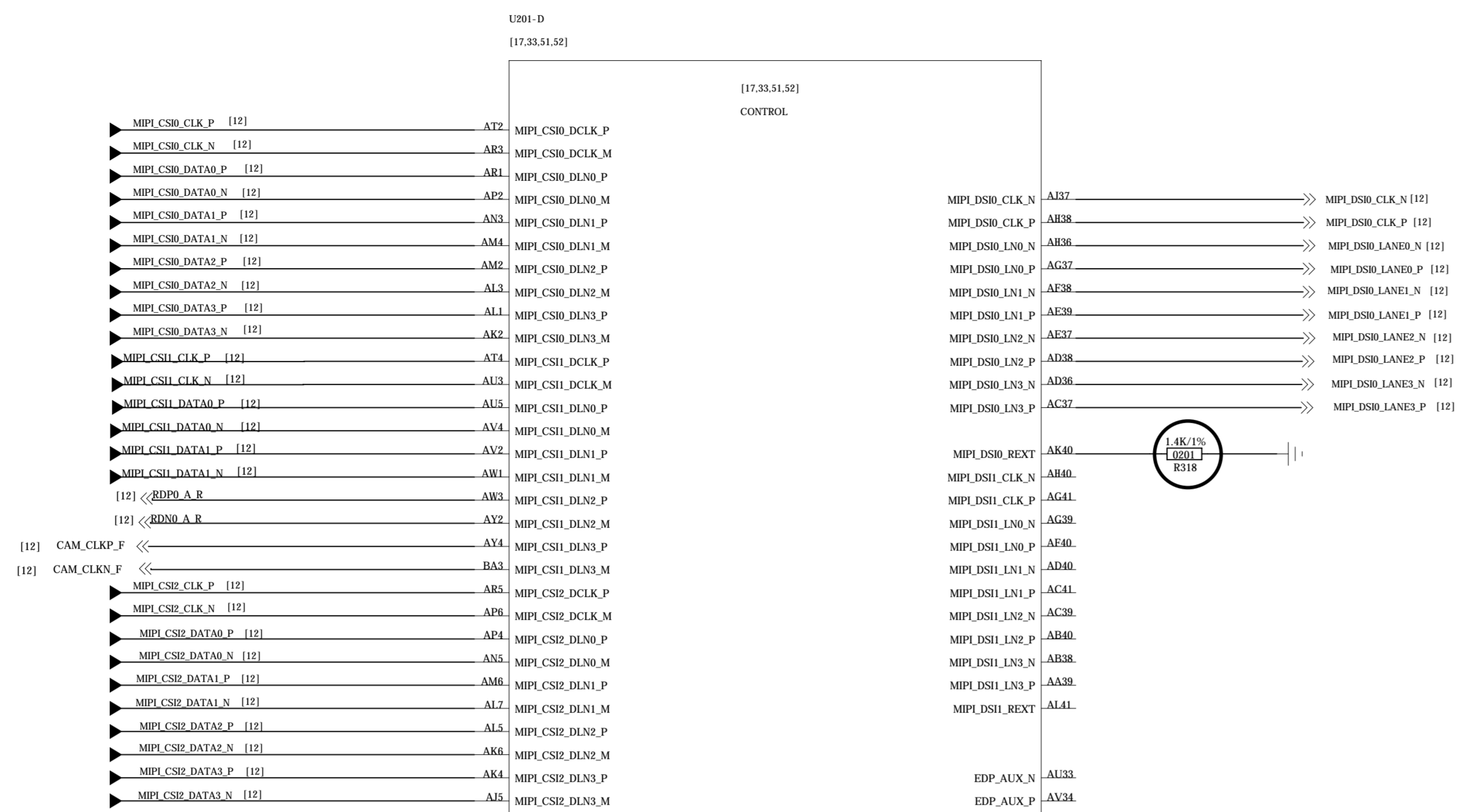

GPIO58 GND for uUSB.
PM660 39 pin for Type C

RF_ANT_CHECK

Reserved for main antenna tuner
Reserved for diversity antenna tuner

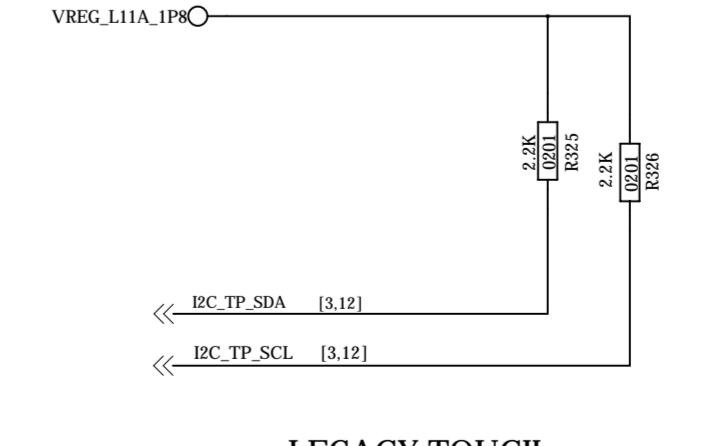
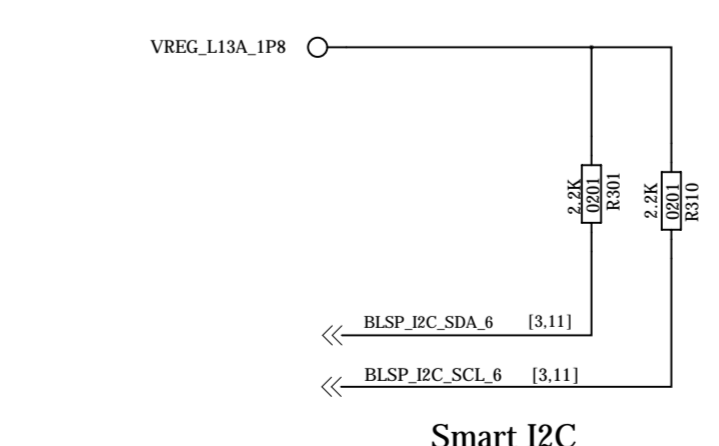
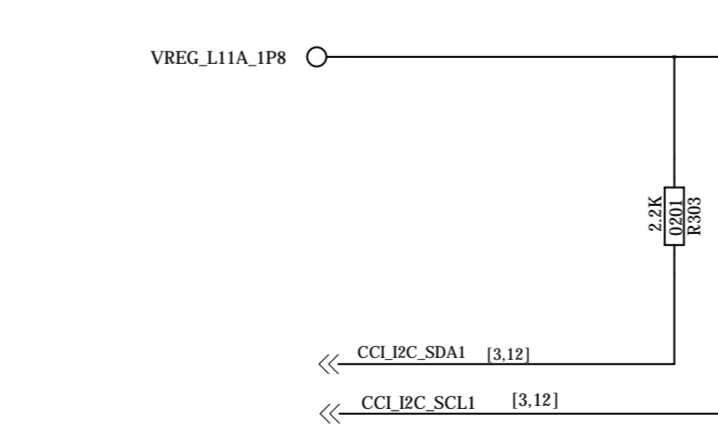
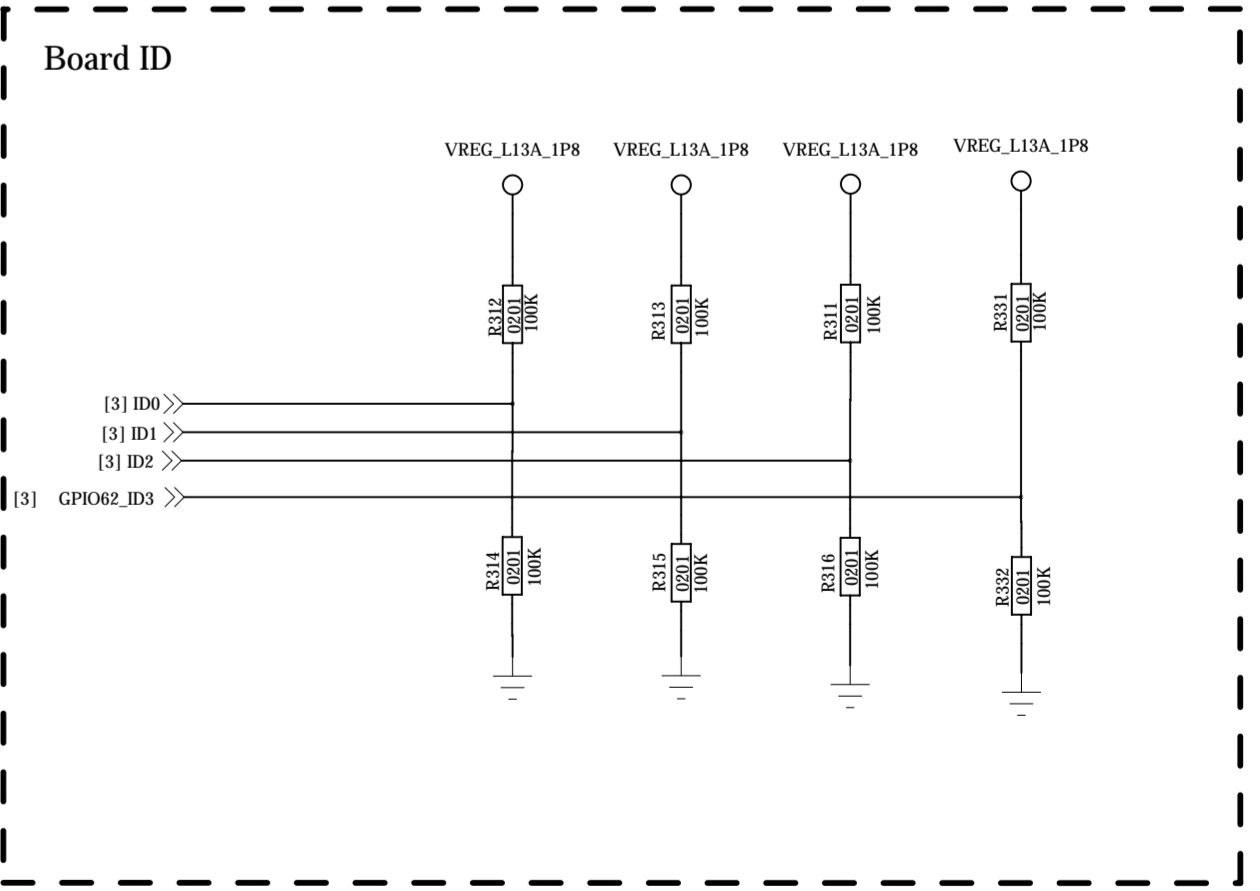
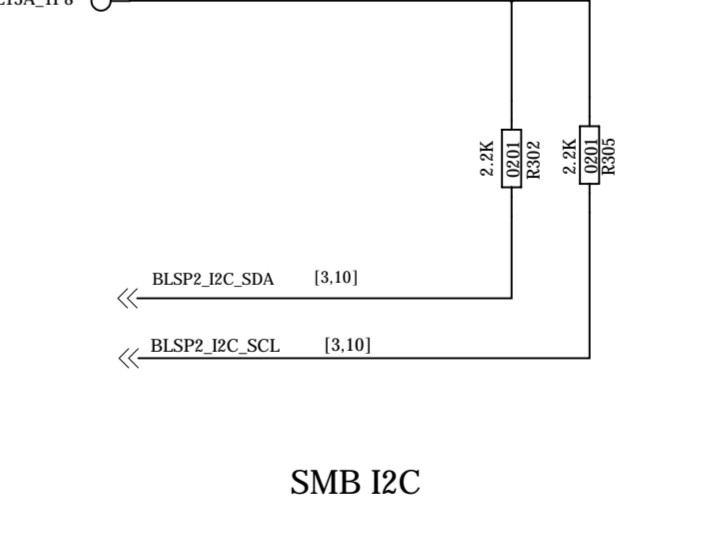
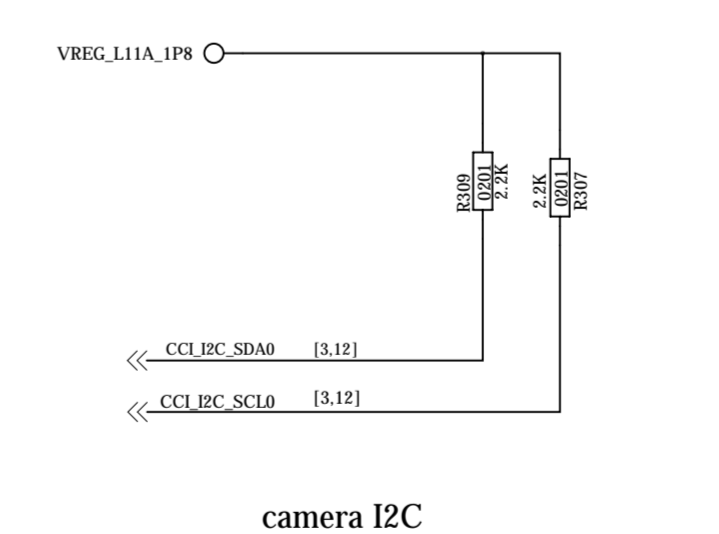
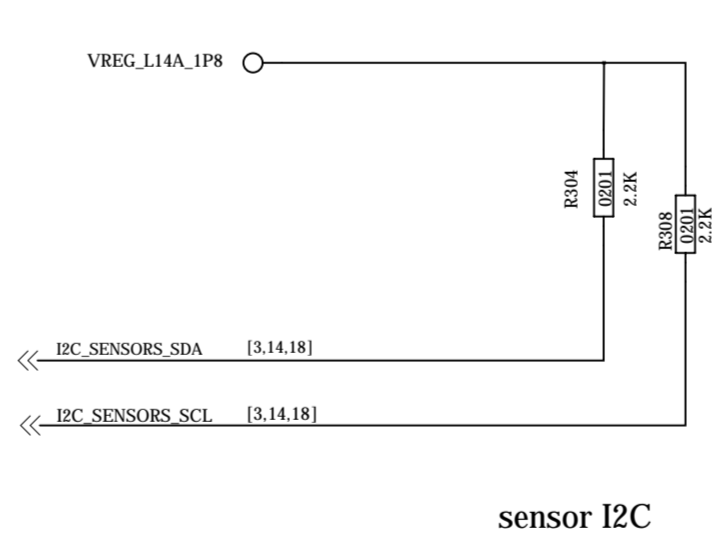

COMPANY: <Company Name>			
TITLE: <Title>			
CODE	SIZE	DRAWING NO	REV.
<Code>	A0	<Drawing Number>	<Revision>
SCALE: <Scale>		SHEET: 3 of 21	

DRAWN	<Drawn By>	DATE	<Drawn Date>
CHECKED	<Checked By>	DATE	<Checked Date>
QUALITY CONTROL	<QC By>	DATE	<QC Date>
RELEASED	<Released By>	DATE	<Release Date>

REVISION RECORD			
LTN	ECO NO.	APPROVED	DATE

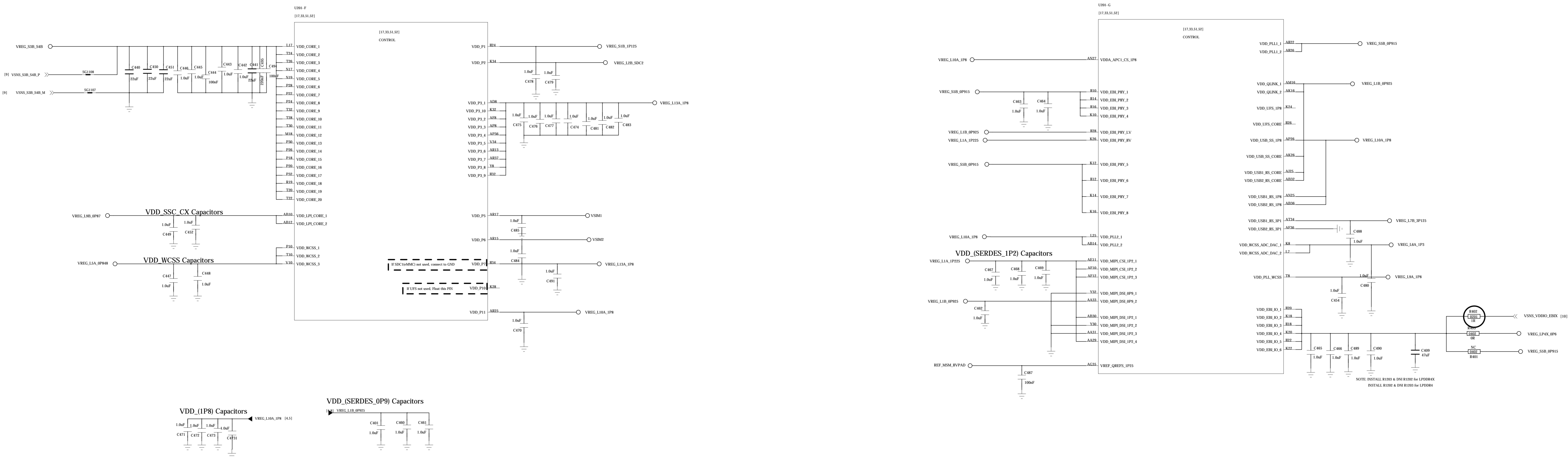
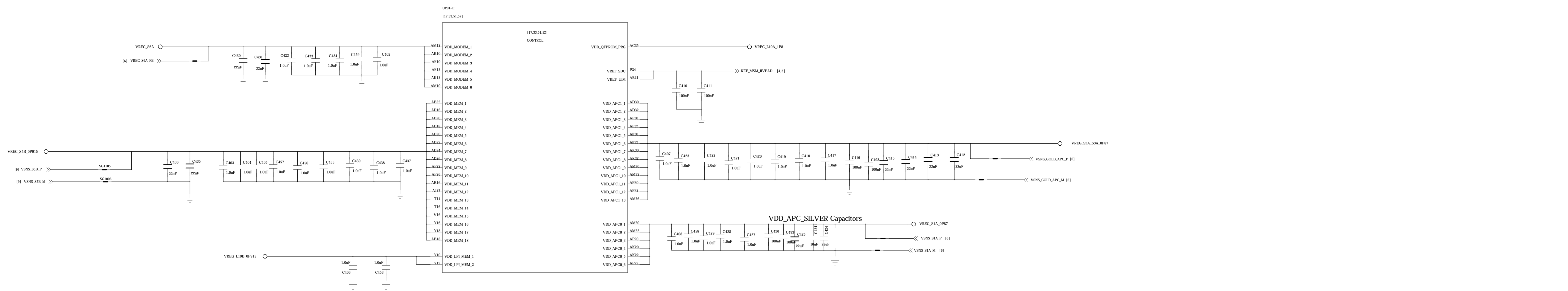

COMPANY: <Company Name>			
TITLE: <Title>			
DRAWN: <Drawn By>	DATED: <Drawn Date>	CODE: <Code>	SIZE: A0
CHECKED: <Checked By>	DATED: <Checked Date>	DRAWING NO: <Drawing Number>	REV: <Revision>
QUALITY CONTROL: <QC By>	DATED: <QC Date>	SCALE: <Scale>	
RELEASED: <Released By>	DATED: <Release Date>	SHEET: 4 OF 21	

REVISION RECORD			
LTR	REV. NO.	APPROVED	DATE

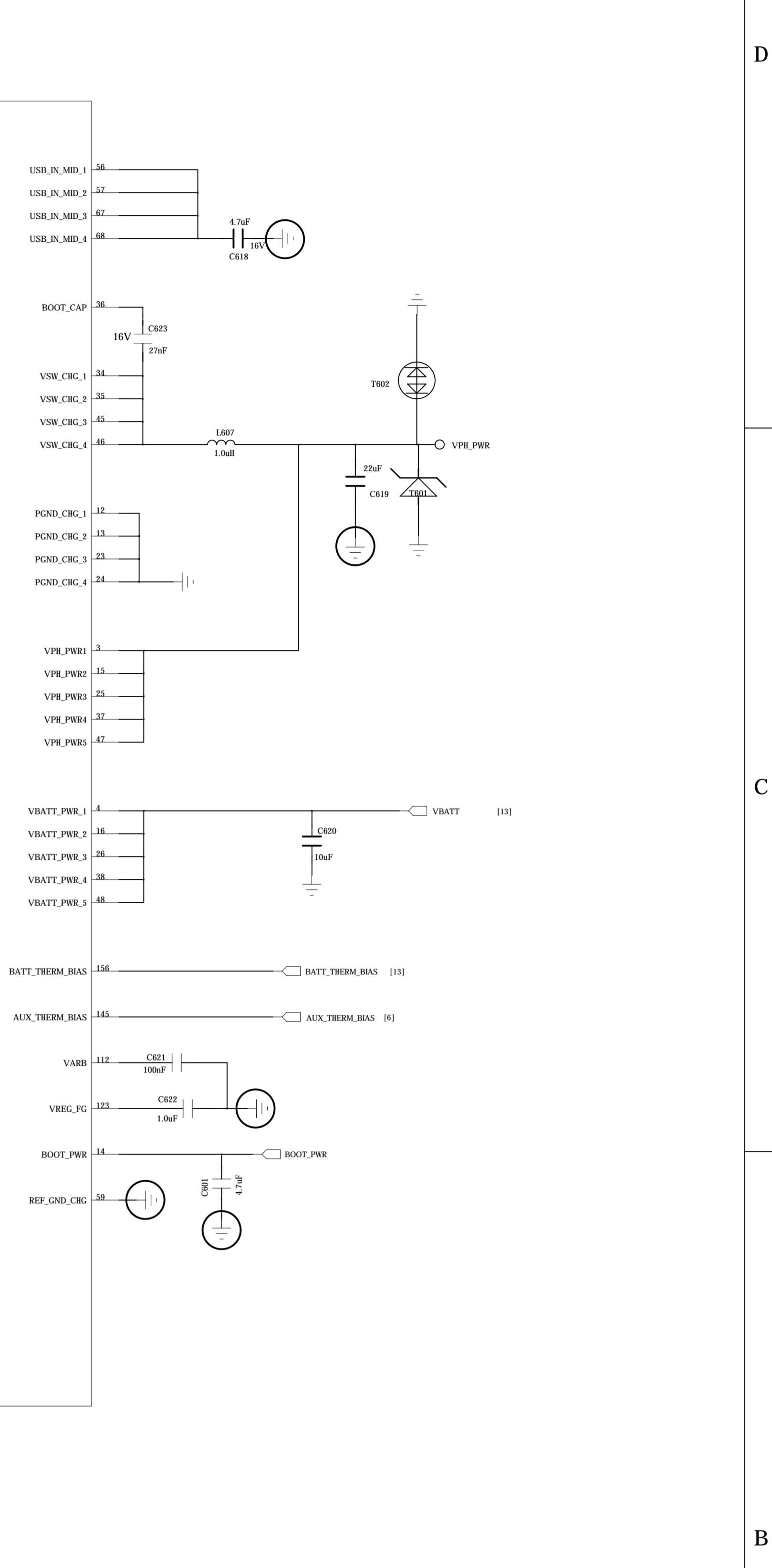
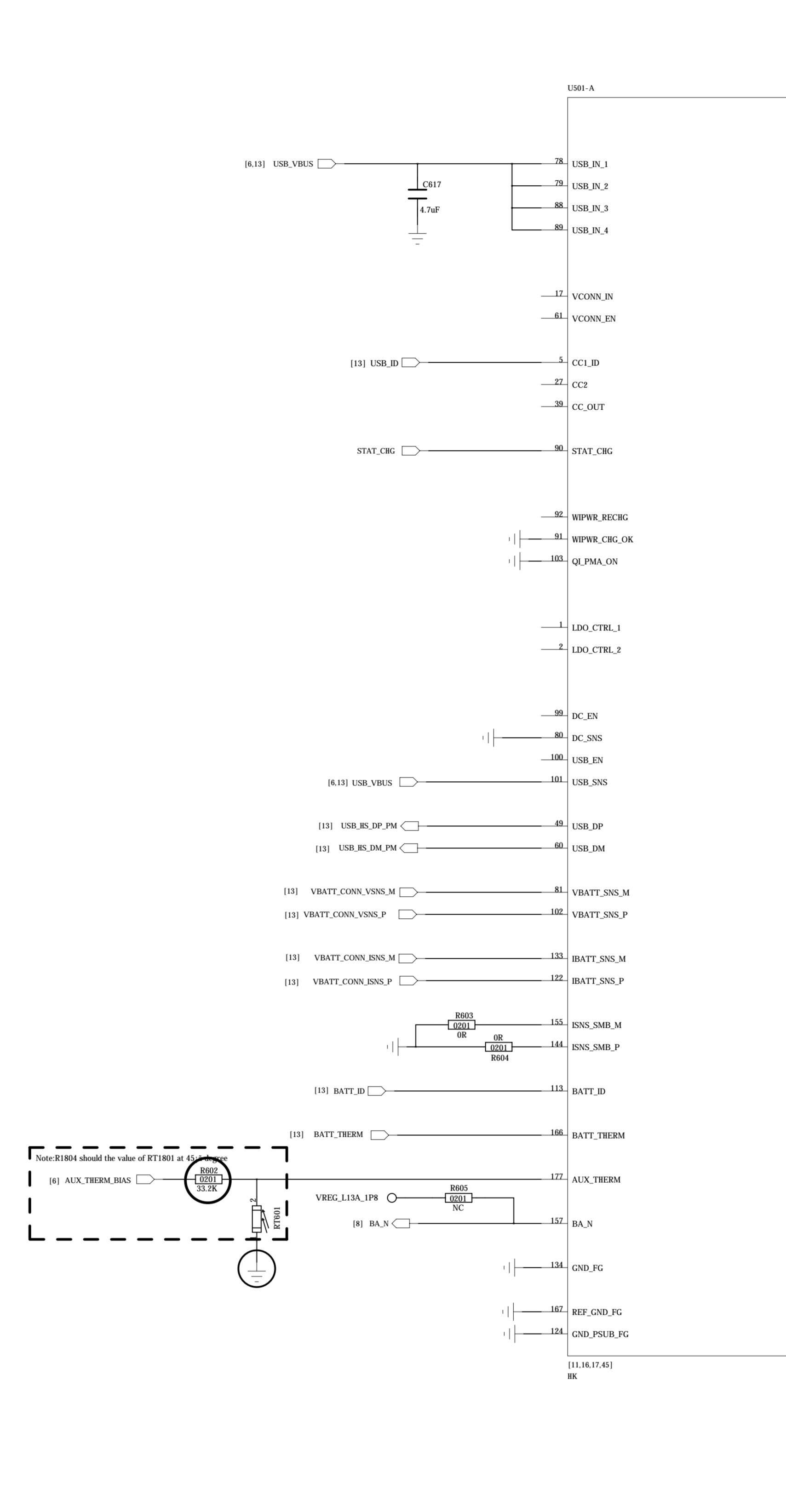
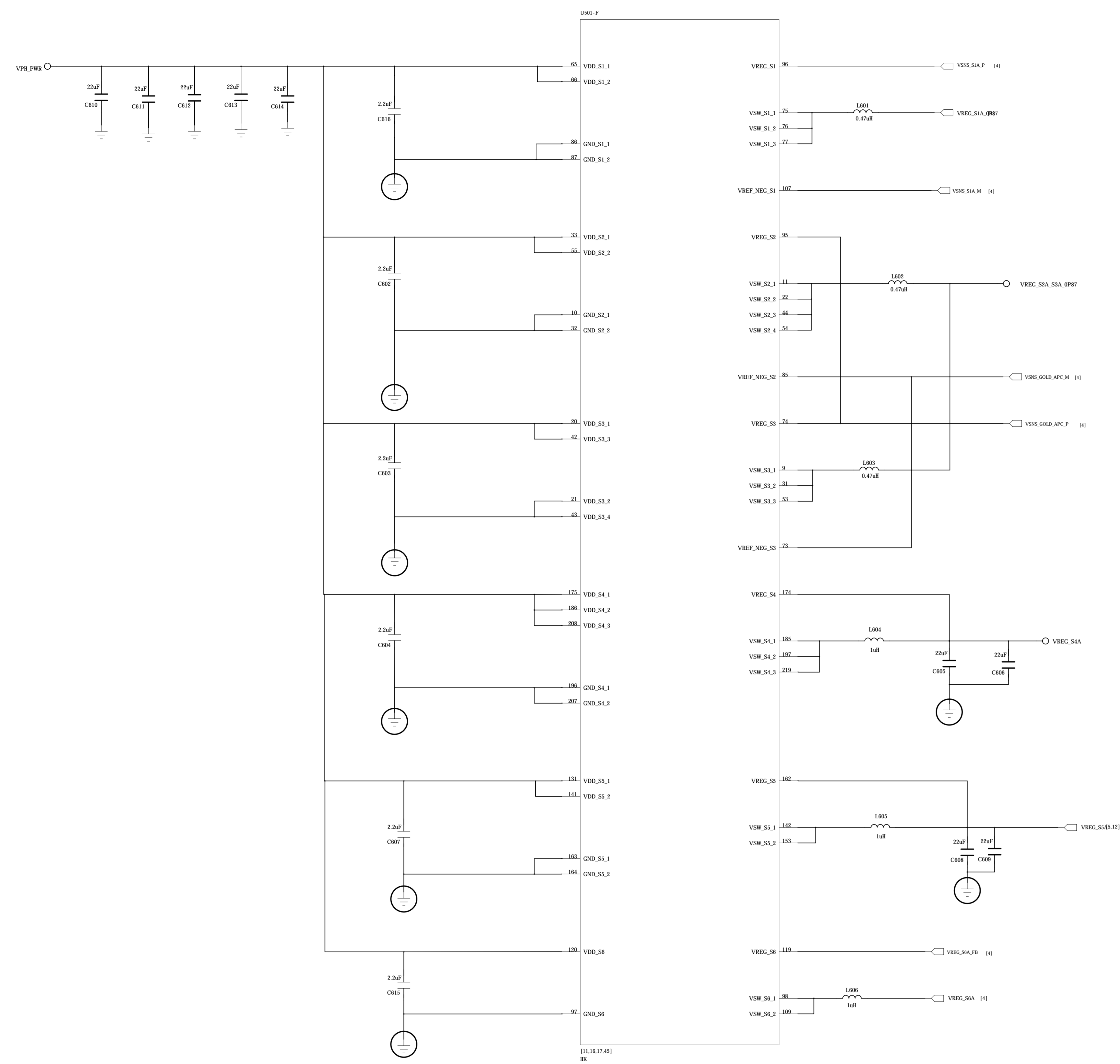

Note: R104 should be the value of R104 in the schematic.

COMPANY: <Company Name>			
TITLE: <Title>			
DATE: <Drawn Date>	DATE: <Checked Date>	CODE: <Code>	SIZE: A0
DRAWN: <Drawn By>	CHECKED: <Checked By>	QUALITY CONTROL: <QC By>	RELEASED: <Released By>
DATE: <Drawn Date>	DATE: <Checked Date>	DATE: <QC Date>	DATE: <Release Date>
DRAWING NO: <Drawing Number>		REV: <Revision>	
SCALE: <Scale>		SHEET: 6 of 21	

6

5

4

3

2

1

REVISION RECORD			
LT#	ECO NO.	APPROVED	DATE

D

D

C

C

B

B

A

A



DRAWN: <Drawn By>		DATE: <Drawn Date>		COMPANY: <Company Name>			
CHECKED: <Checked By>		DATE: <Checked Date>		TITLE: <Title>			
QUALITY CONTROL: <QC By>		DATE: <QC Date>		CODE: <Code>	SIZE: A0	DRAWING NO: <Drawing Number>	REV: <Revision>
RELEASED: <Released By>		DATE: <Release Date>		SCALE: <Scale>		SHEET 7 of 21	

REVISION RECORD			
LT#	REV. NO.	APPROVED:	DATE:

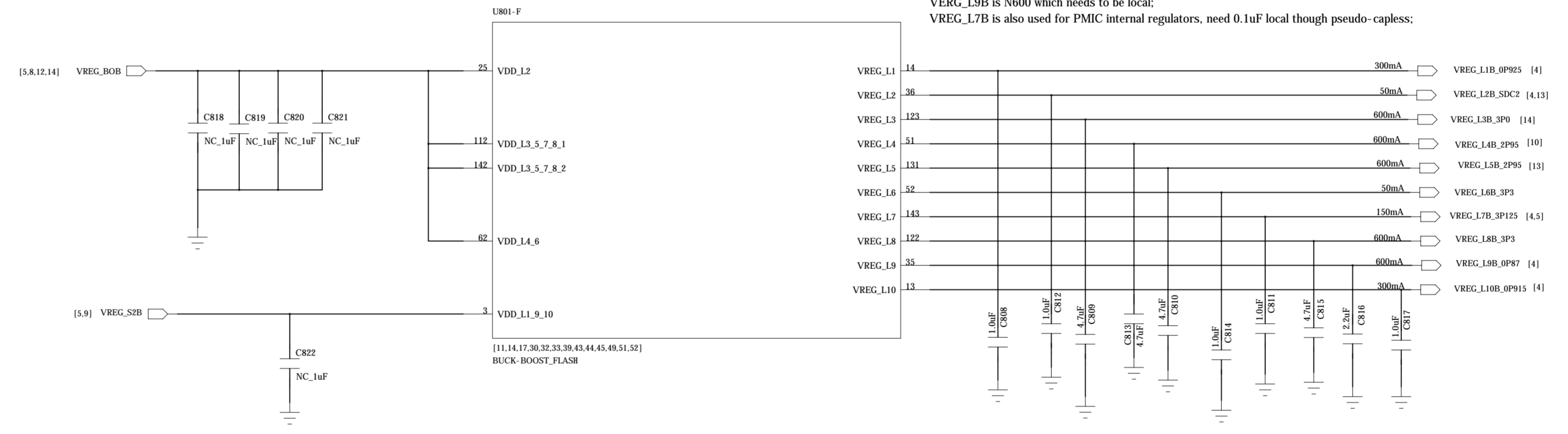
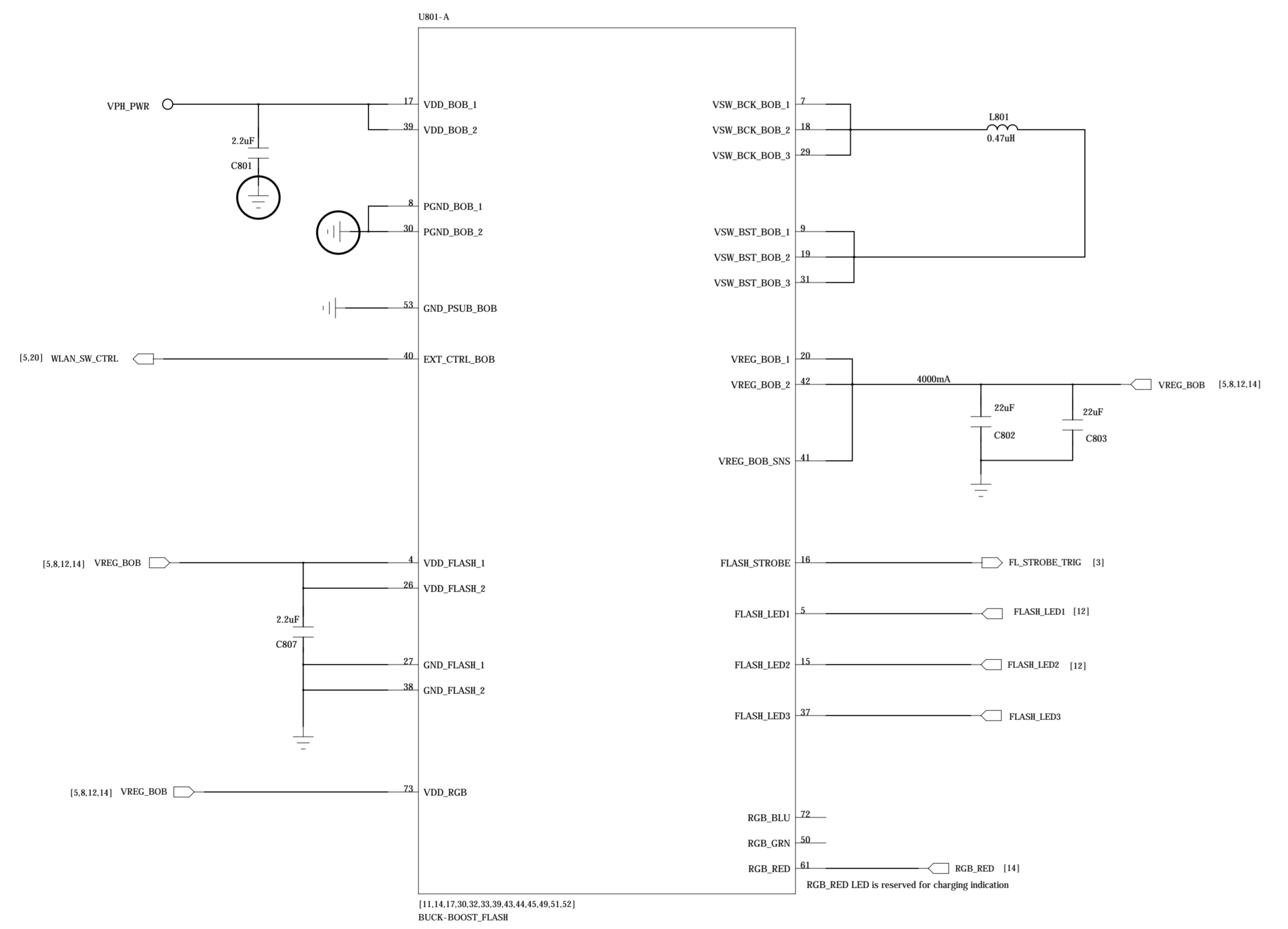
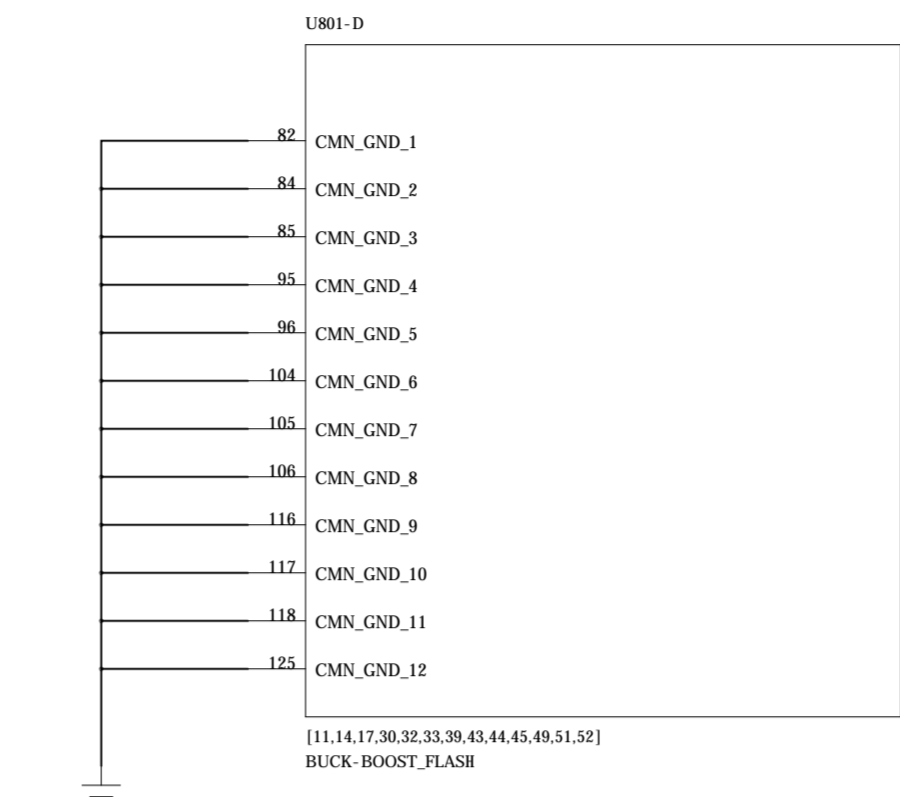
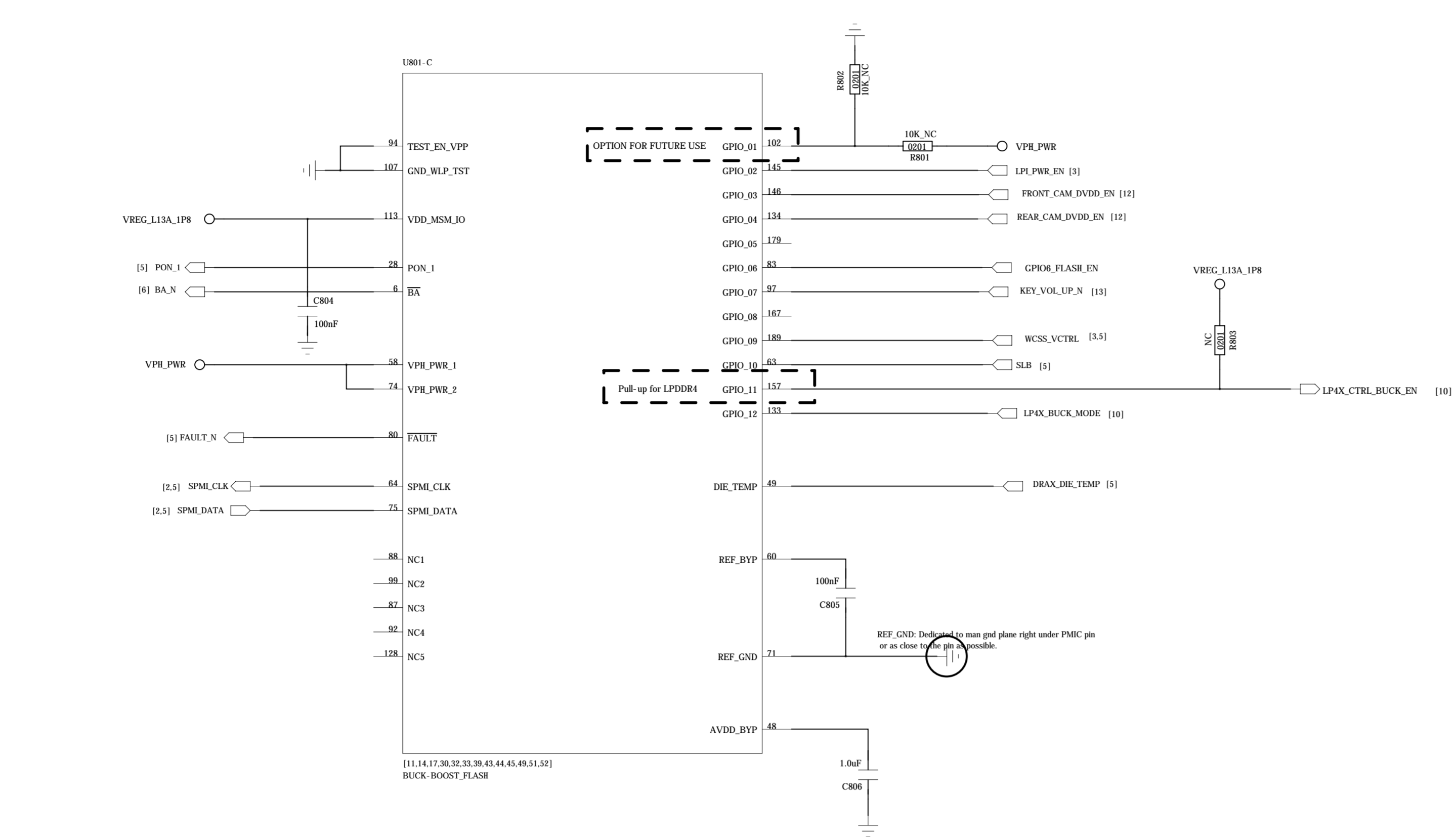

P-type are pseudo-capacitors, cap can be at load.
 Regulators used internal to PMIC need cap at PMIC.
 N-type - N300 need cap at PMIC.
 VREG_1,9B is N300 which needs to be local.
 VREG_1,11B is also used for PMIC internal regulators, need 0.1uF local though pseudo-capacitors.

COMPANY: <Company Name>	
TITLE: <Title>	
DATE: <Drawn Date>	DATE: <Checked Date>
DRAWN: <Drawn By>	CHECKED: <Checked By>
DATE: <QC Date>	DATE: <Release Date>
RELEASED: <Released By>	DATE: <Release Date>
CODE: <Code>	SIZE: A0
DRAWING NO: <Drawing Number>	
REV: <Revision>	
SCALE: <Scale>	
SHEET 8 of 21	

REVISION RECORD			
LT#	ECO NO.	APPROVED	DATE

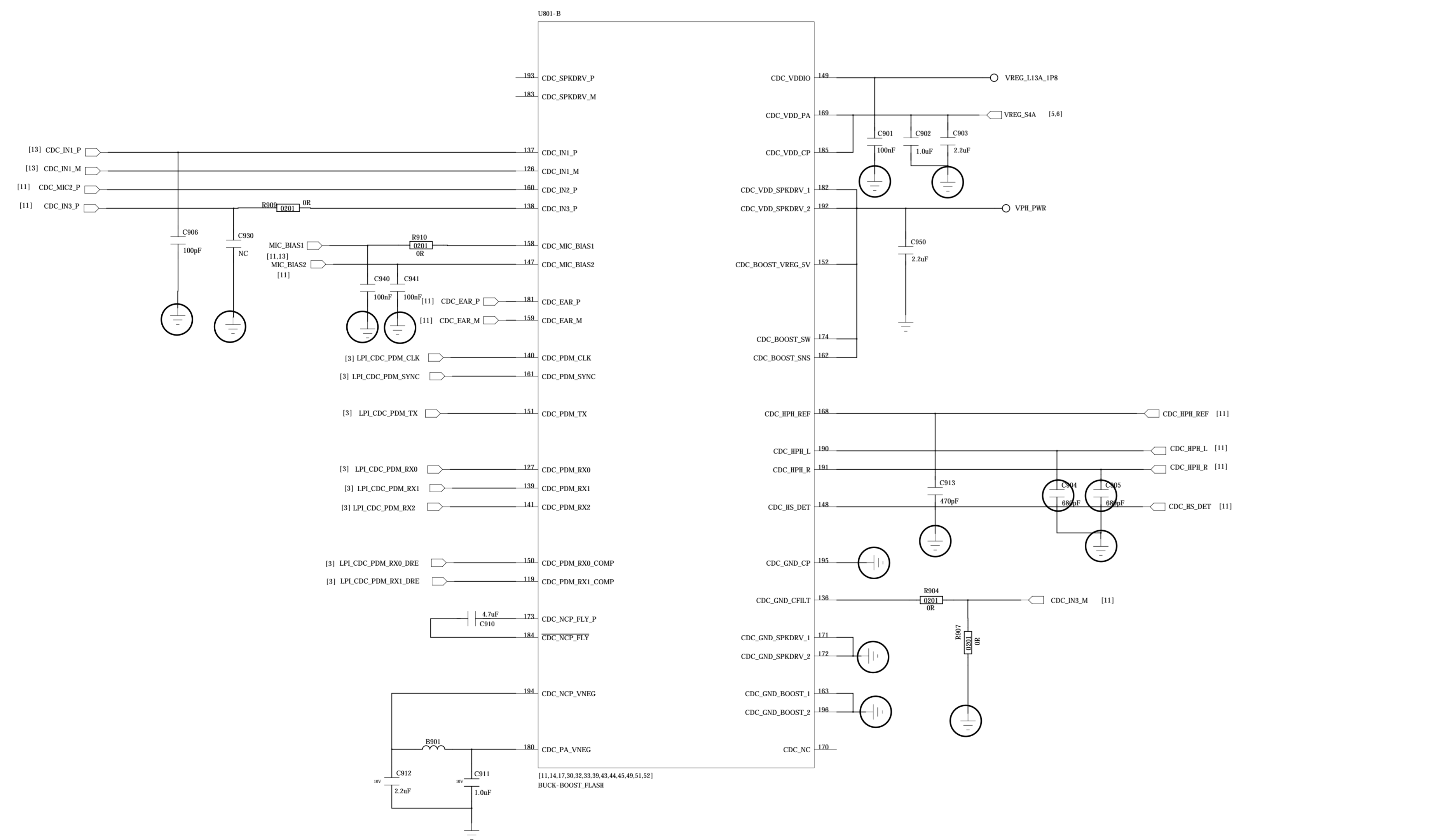
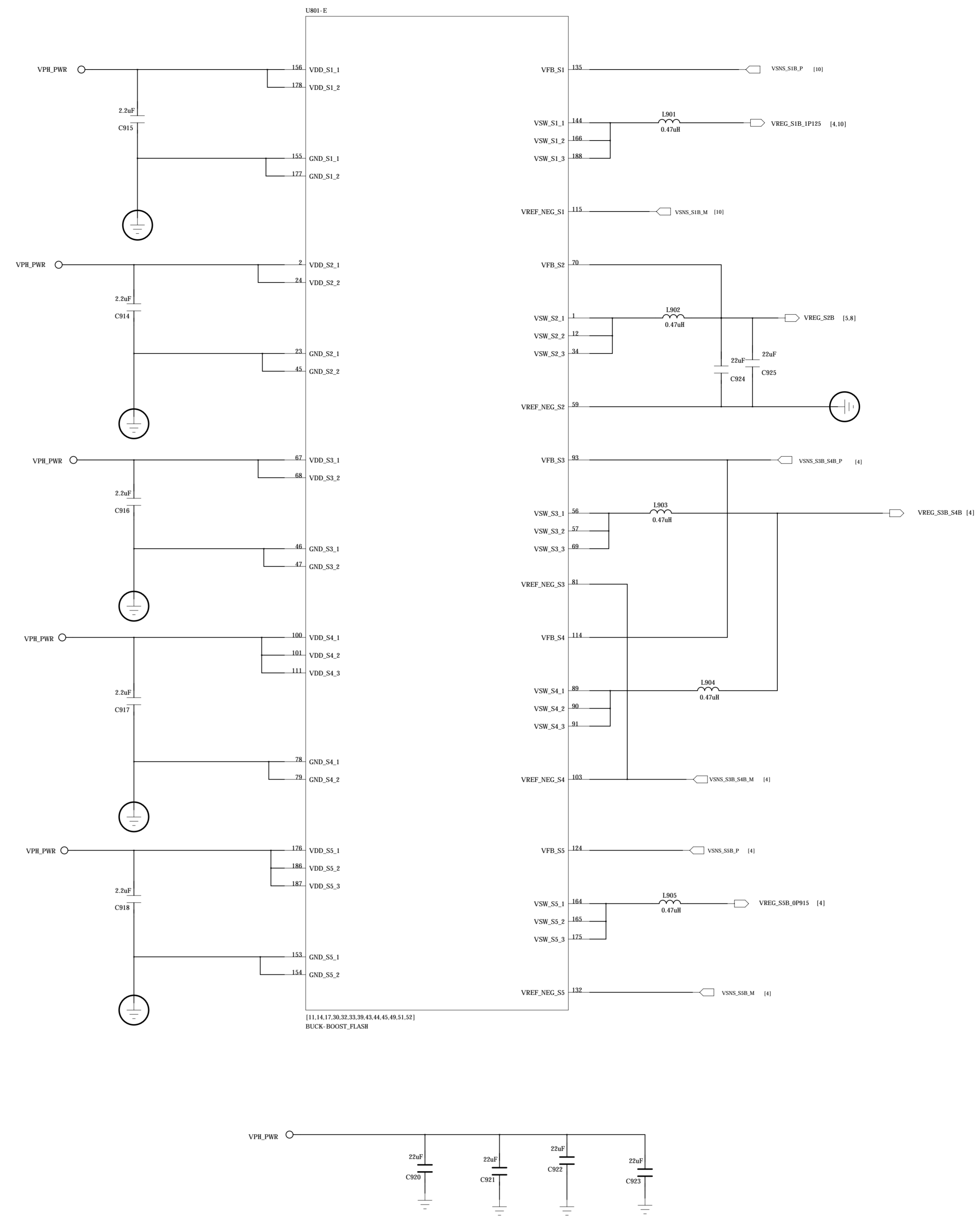
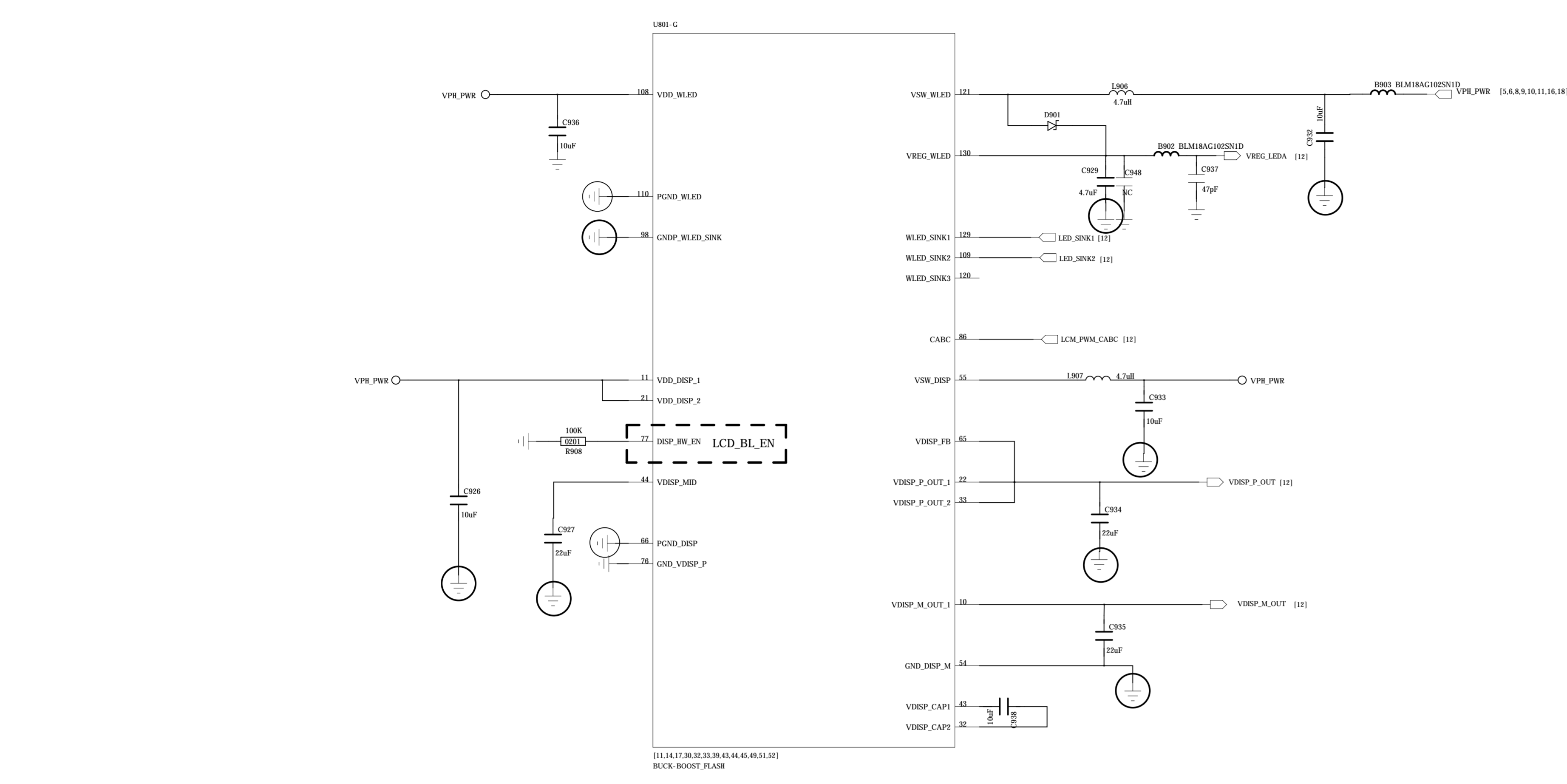

DRAWN: <Drawn By>		DATE: <Drawn Date>	
CHECKED: <Checked By>		DATE: <Checked Date>	
QUALITY CONTROL: <QC By>		DATE: <QC Date>	
RELEASED: <Released By>		DATE: <Release Date>	
COMPANY: <Company Name>		TITLE: <Title>	
CODE: <Code>	SIZE: A0	DRAWING NO: <Drawing Number>	REV: <Revision>
SCALE: <Scale>		SHEET: 9/6 21	

REVISION RECORD			
LT#	ECO NO.	APPROVED	DATE

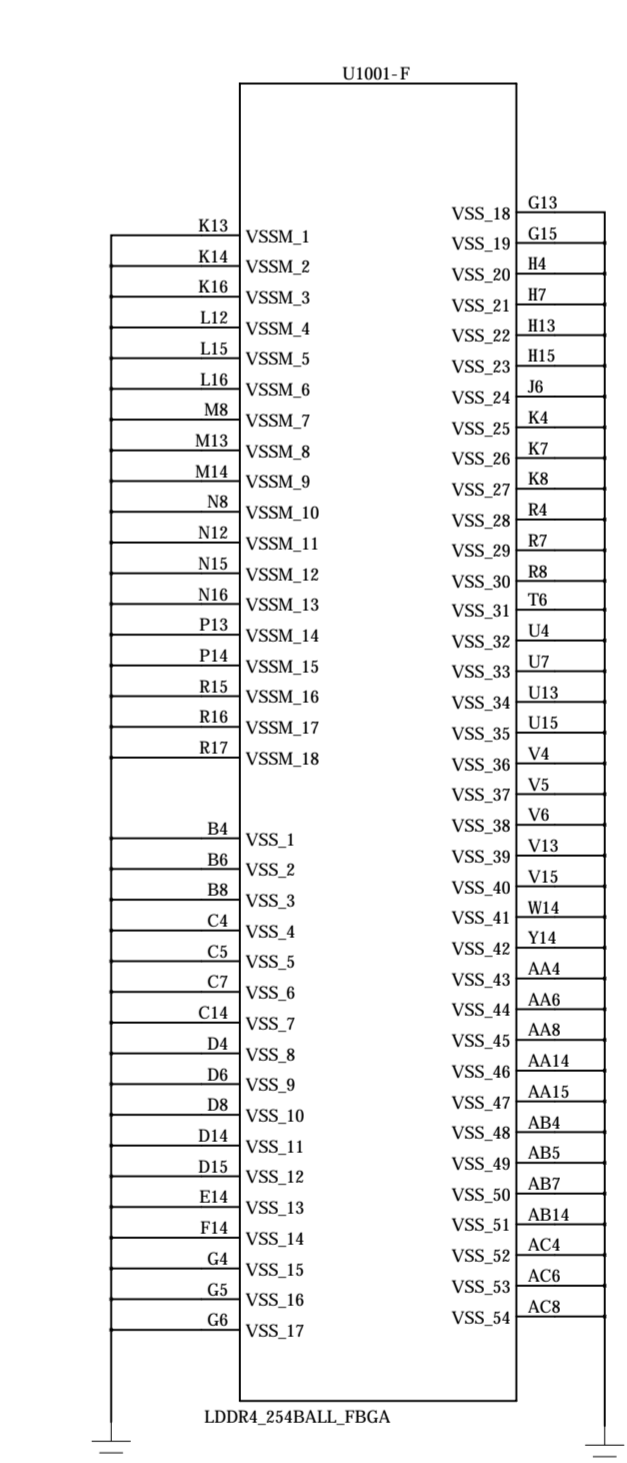
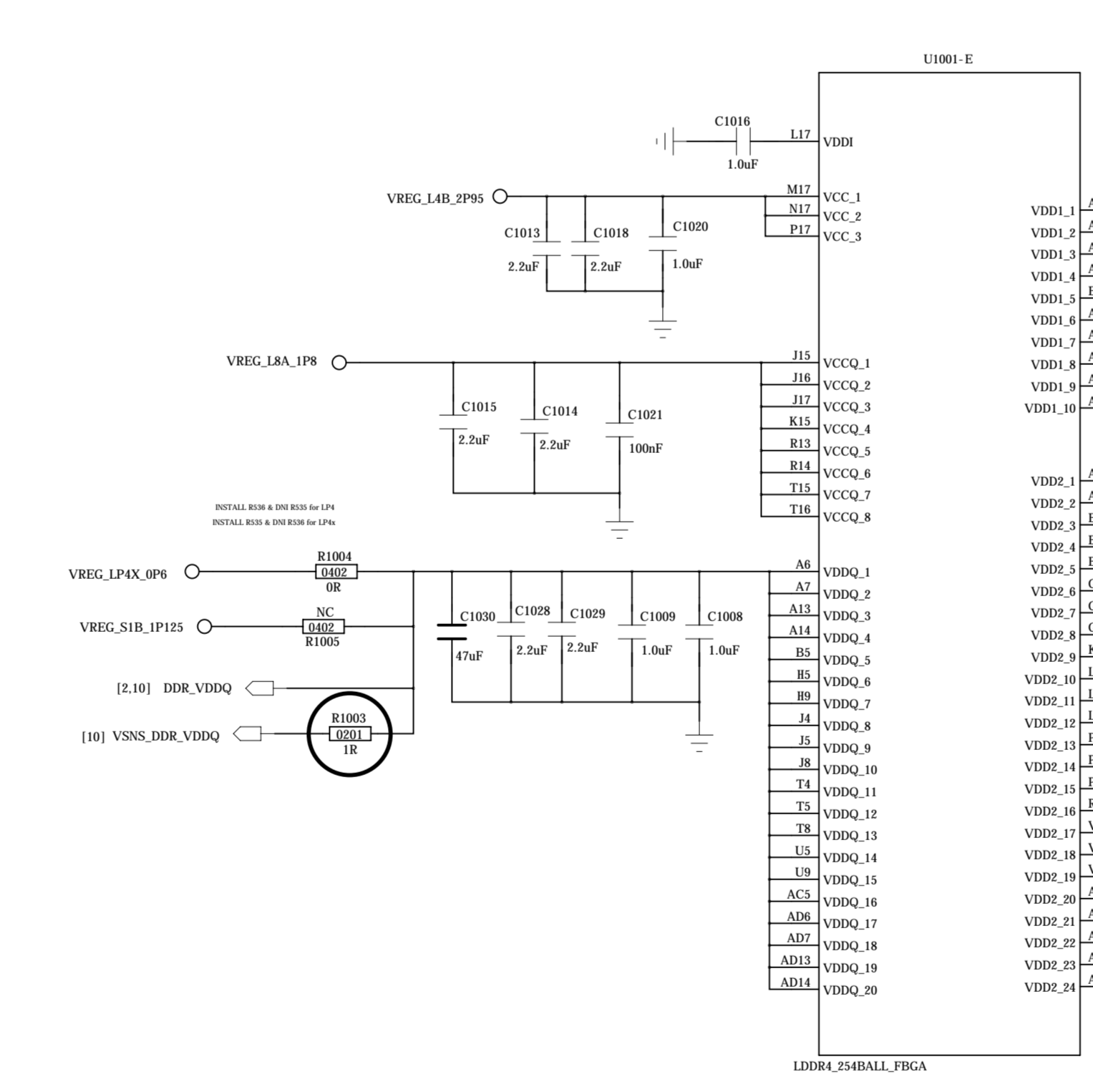
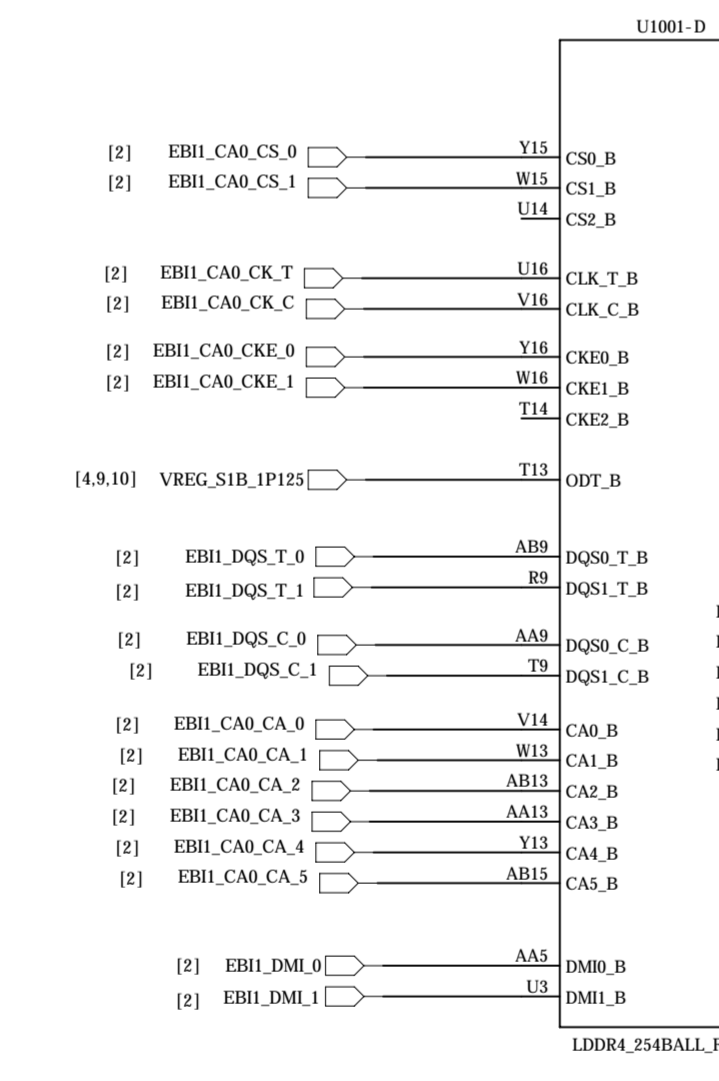
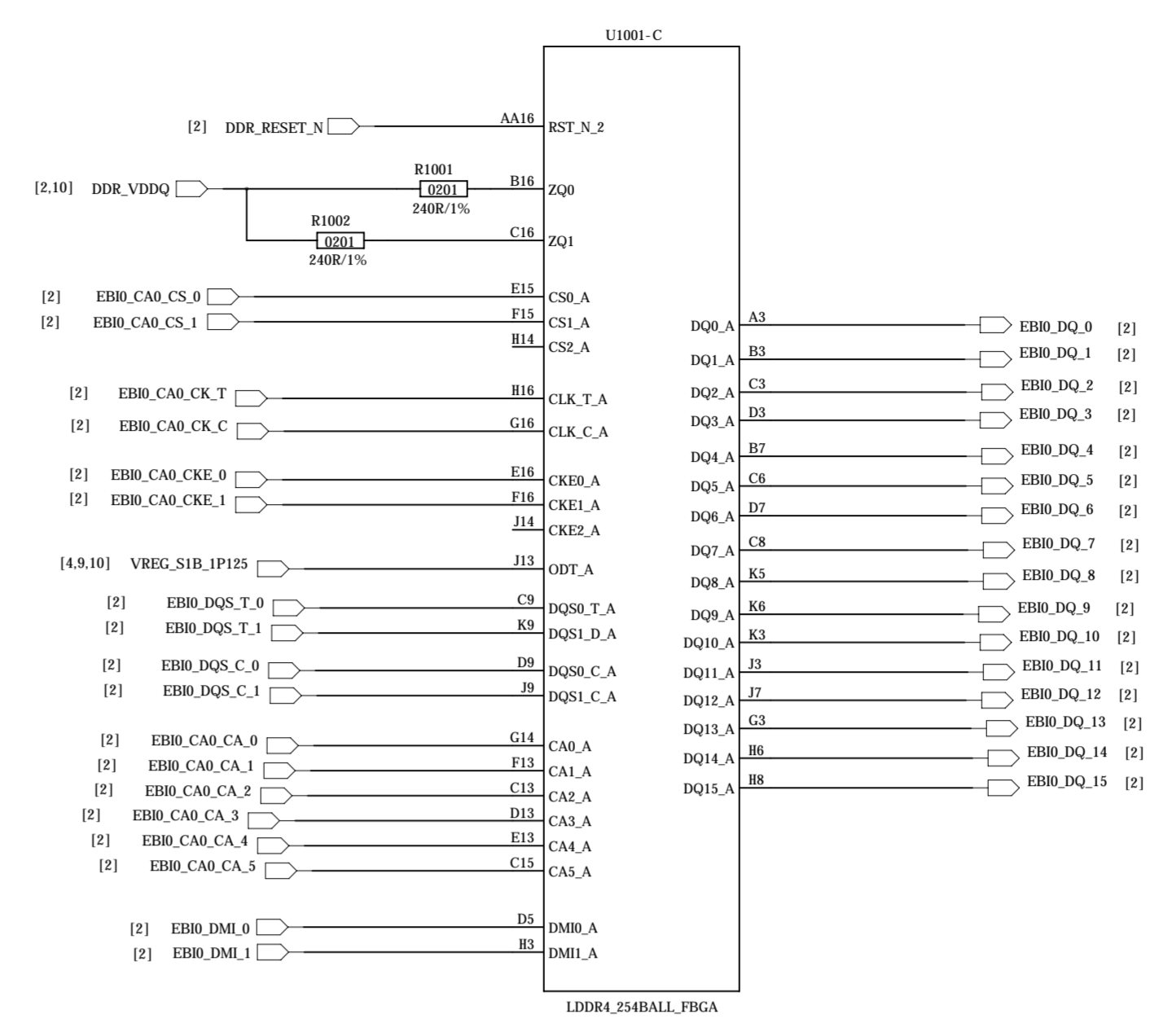
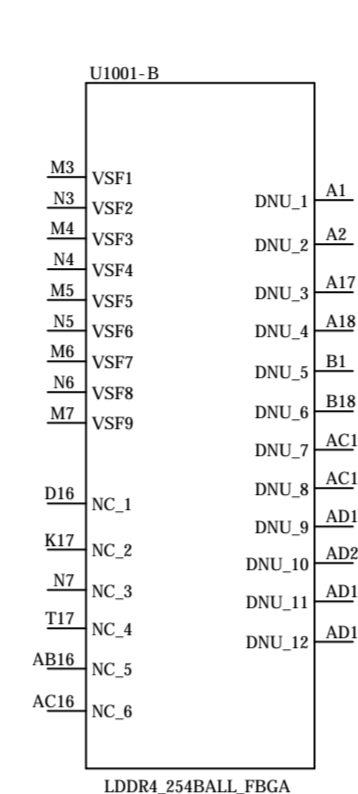
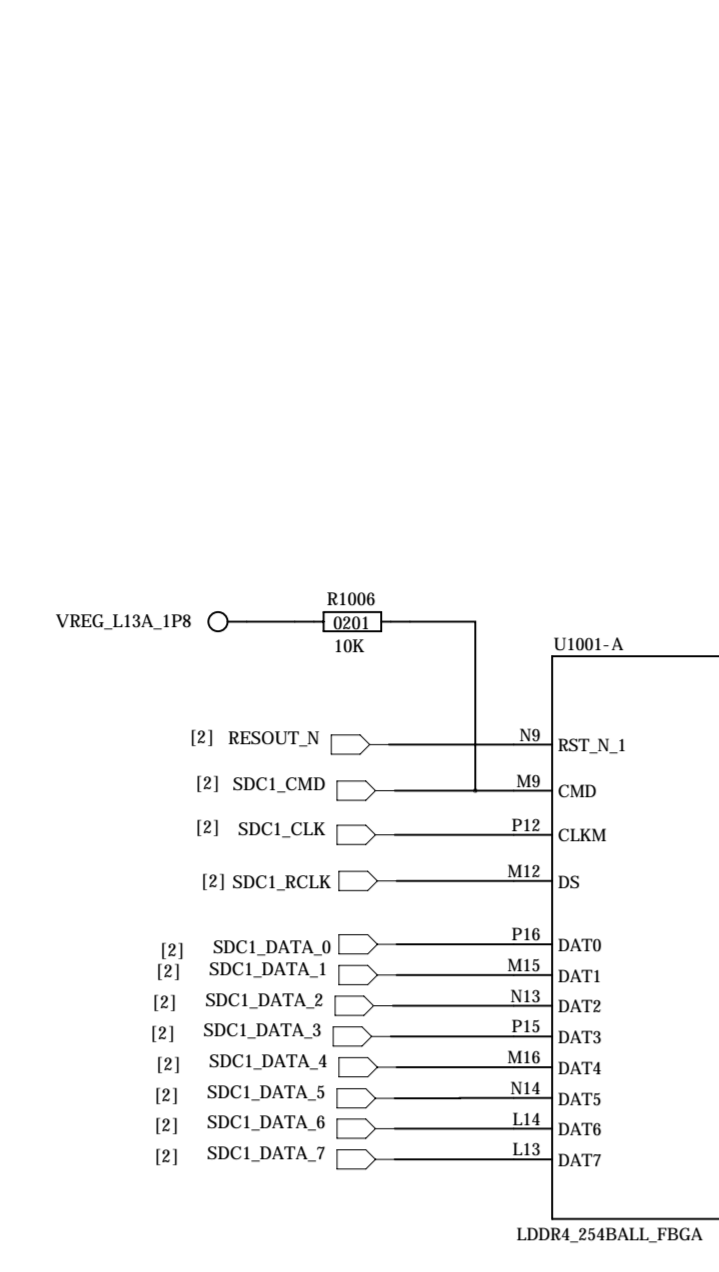

Buck for VDRAM
FANS5326 / Buck I2C address: 0X60 (Write:0xC0, Read:0xC1)

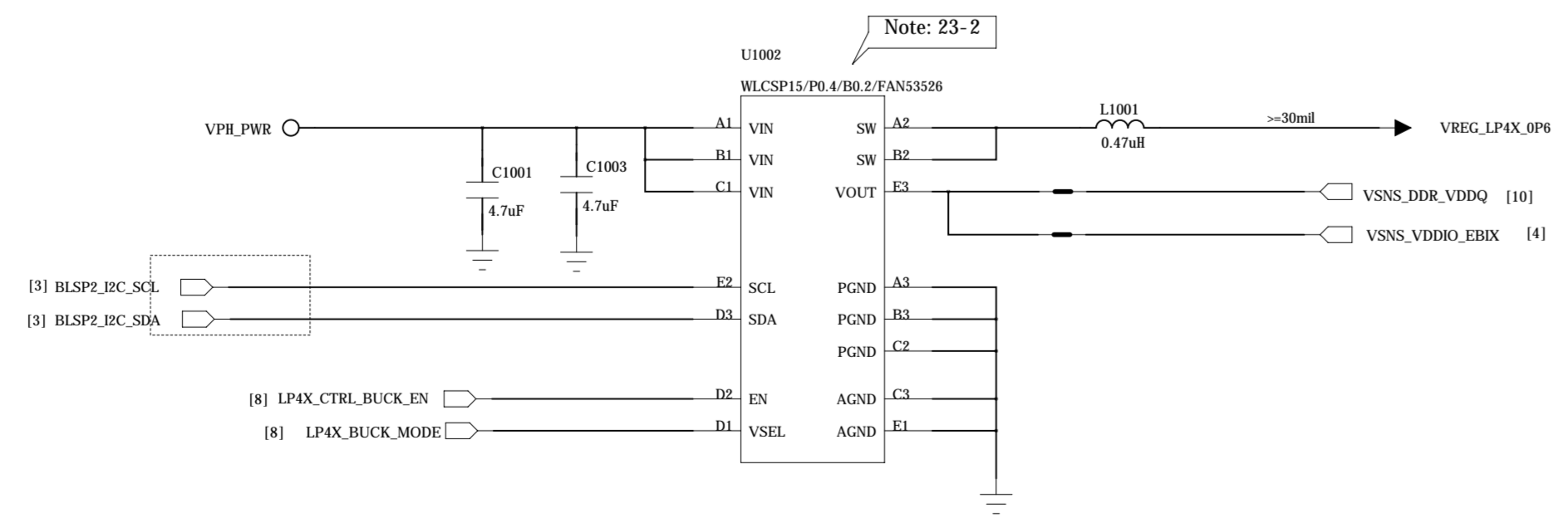

COMPANY: <Company Name>			
TITLE: <Title>			
DATE: <Drawn Date>	DATE: <Checked Date>	CODE: <Code>	SIZE: A0
DRAWN: <Drawn By>	CHECKED: <Checked By>	QUALITY CONTROL: <QC Date>	SCALE: <Scale>
RELEASED: <Released By>	DATE: <Release Date>	DRAWING NO: <Drawing Number> <Revision>	
SHEET 10		21	

REVISION RECORD			
LT#	REV NO	APPROVED	DATE

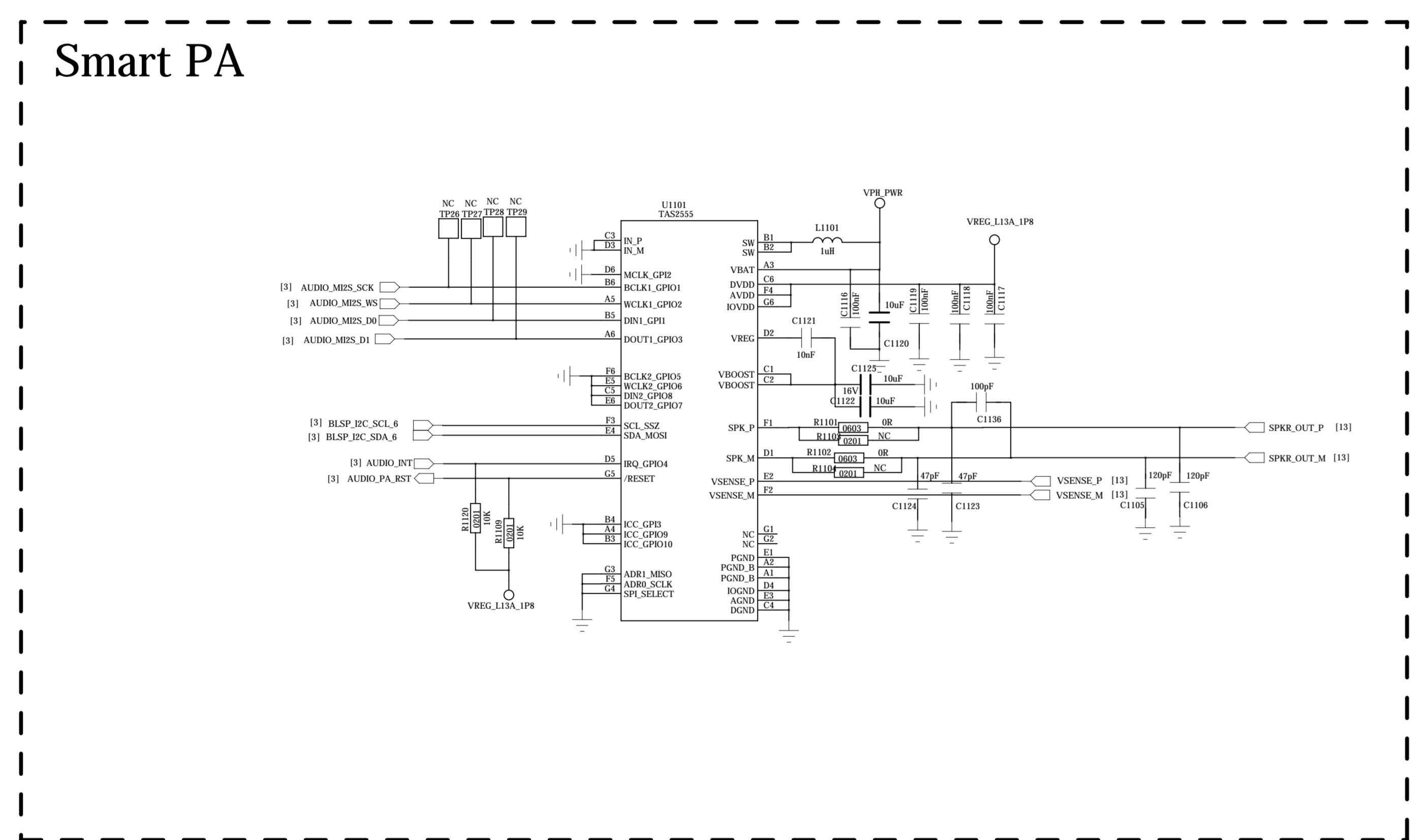
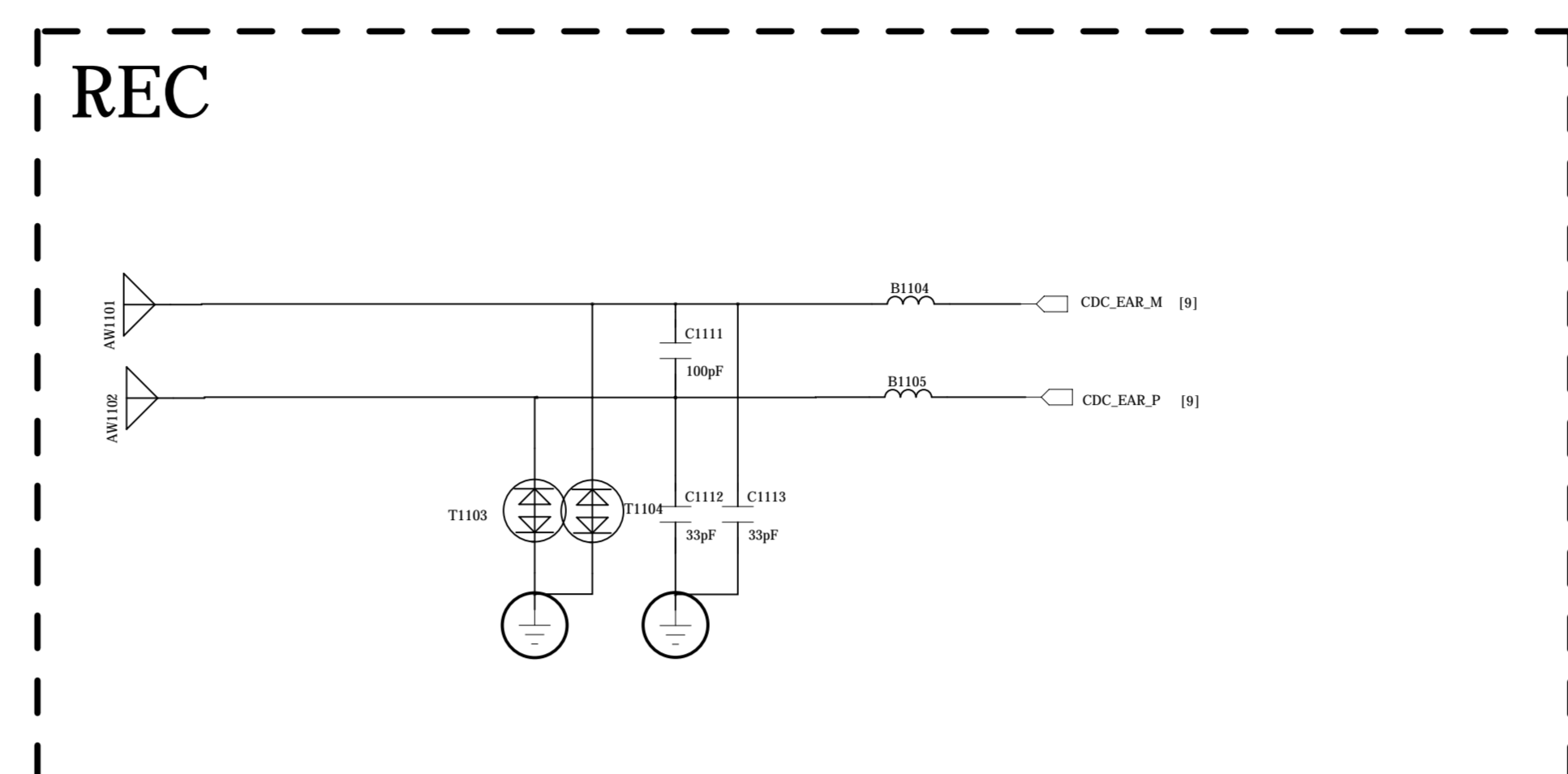
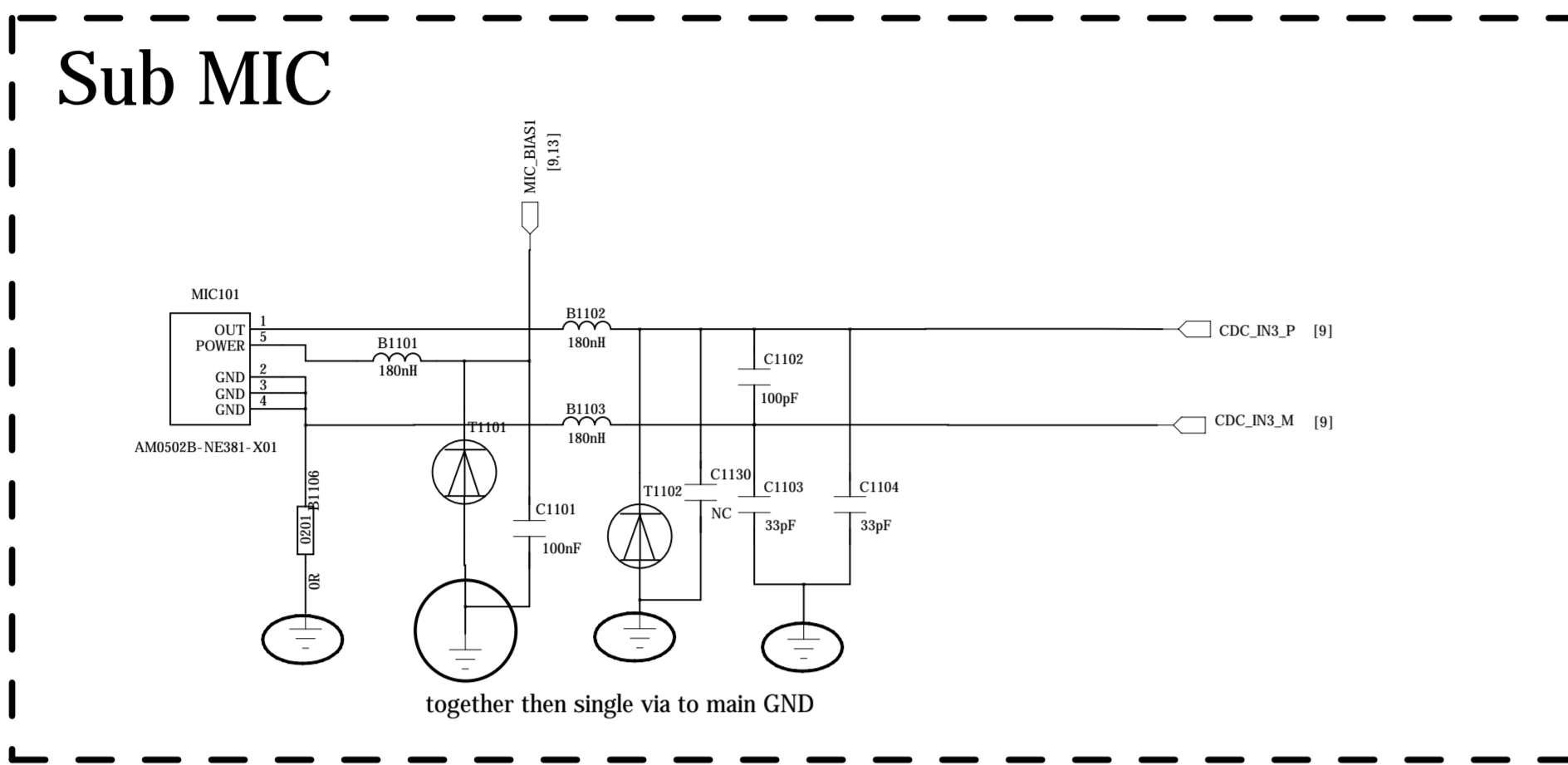

Earphone Audio

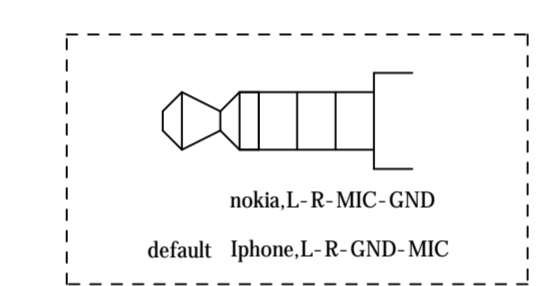

Note: Ferrite beads and their corresponding bypass capacitors on CDC_IPH_L_P, CDC_IPH_L_M and CDC_IPH_REF are needed to reduce noise generated by audio/FM concurrency

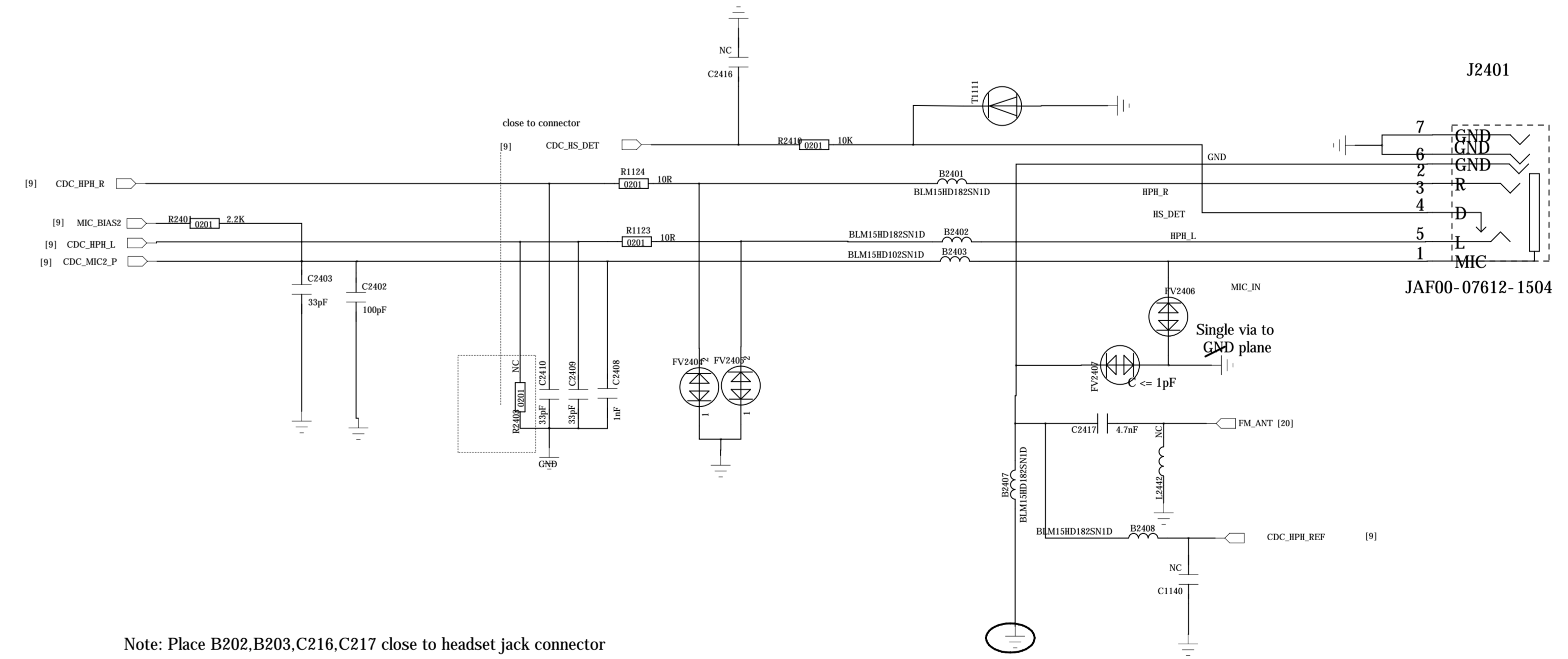

Note: Place B202, B203, C216, C217 close to headset jack connector
Note: For Cable detection



COMPANY: <Company Name>			
TITLE: <Title>			
DRAWN: <Drawn By>	DATE: <Drawn Date>	CODE: <Code>	SIZE: A0
CHECKED: <Checked By>	DATE: <Checked Date>	DRAWING NO: <Drawing Number><Revision>	
QUALITY CONTROL: <QC By>	DATE: <QC Date>	SCALE: <Scale>	SHEET 11 21
RELEASED: <Released By>	DATE: <Release Date>		

REVISION RECORD			
LT#	ECO NO.	APPROVED:	DATE:

Main Camera A

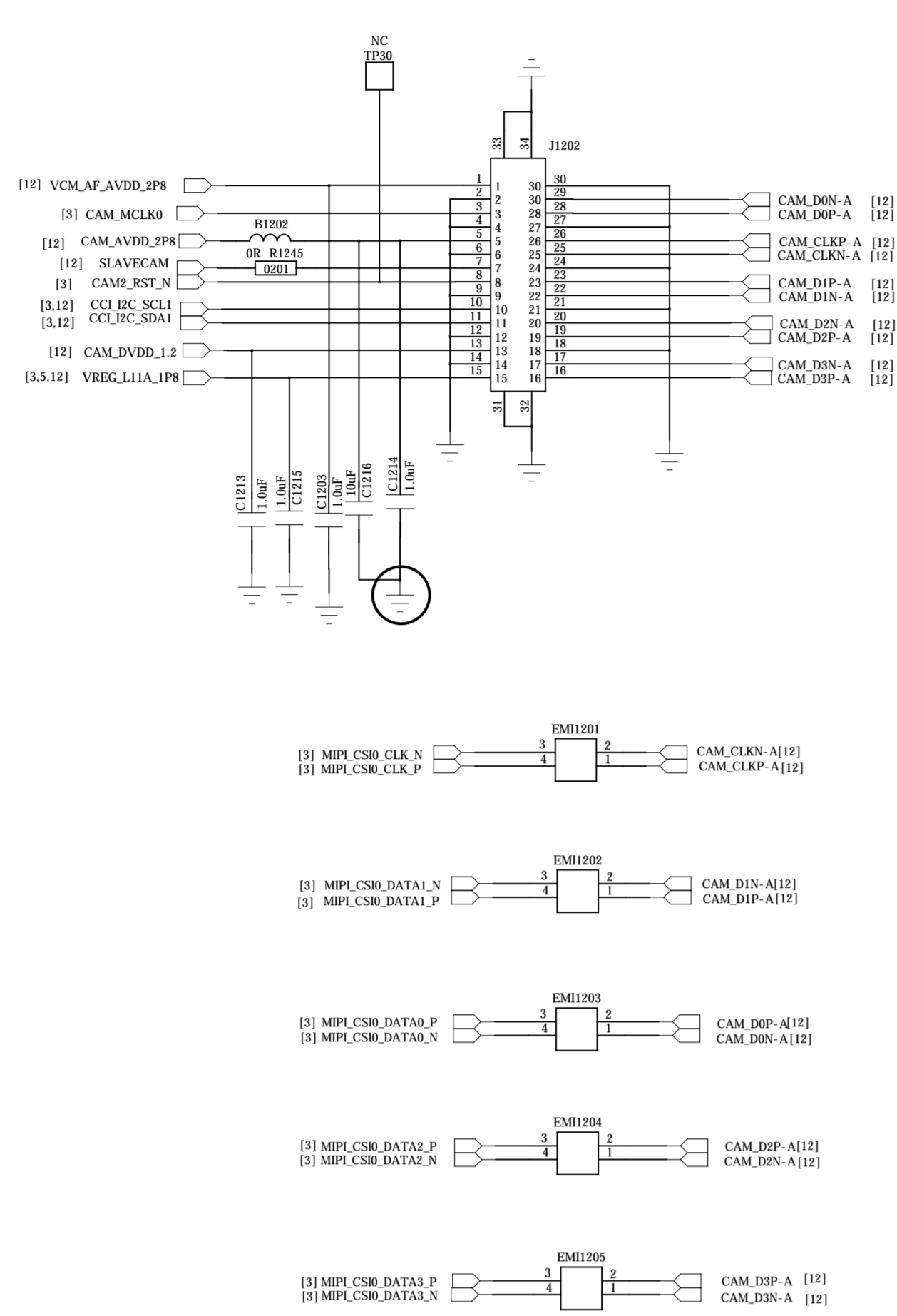

Main Camera B

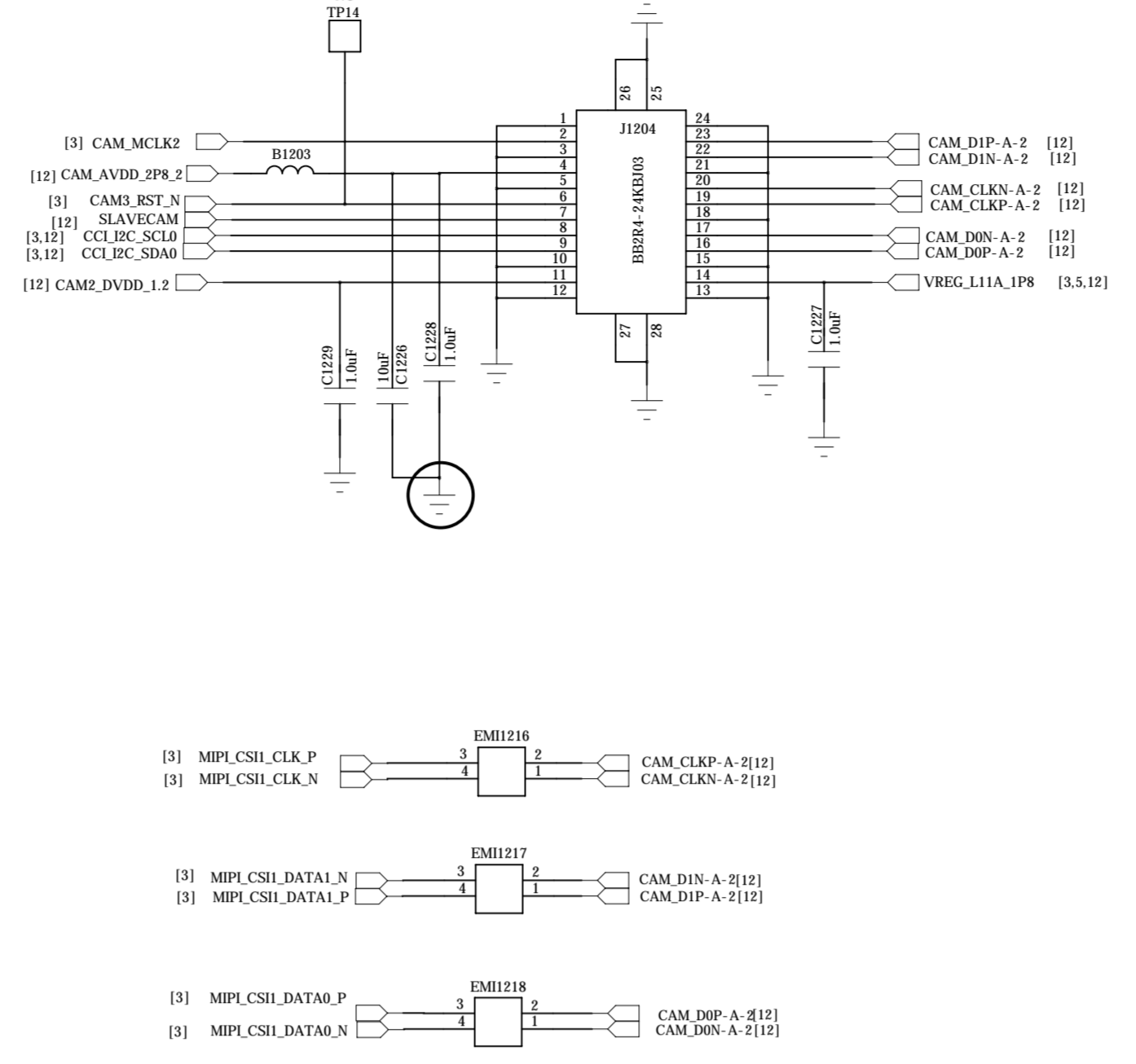

LCM

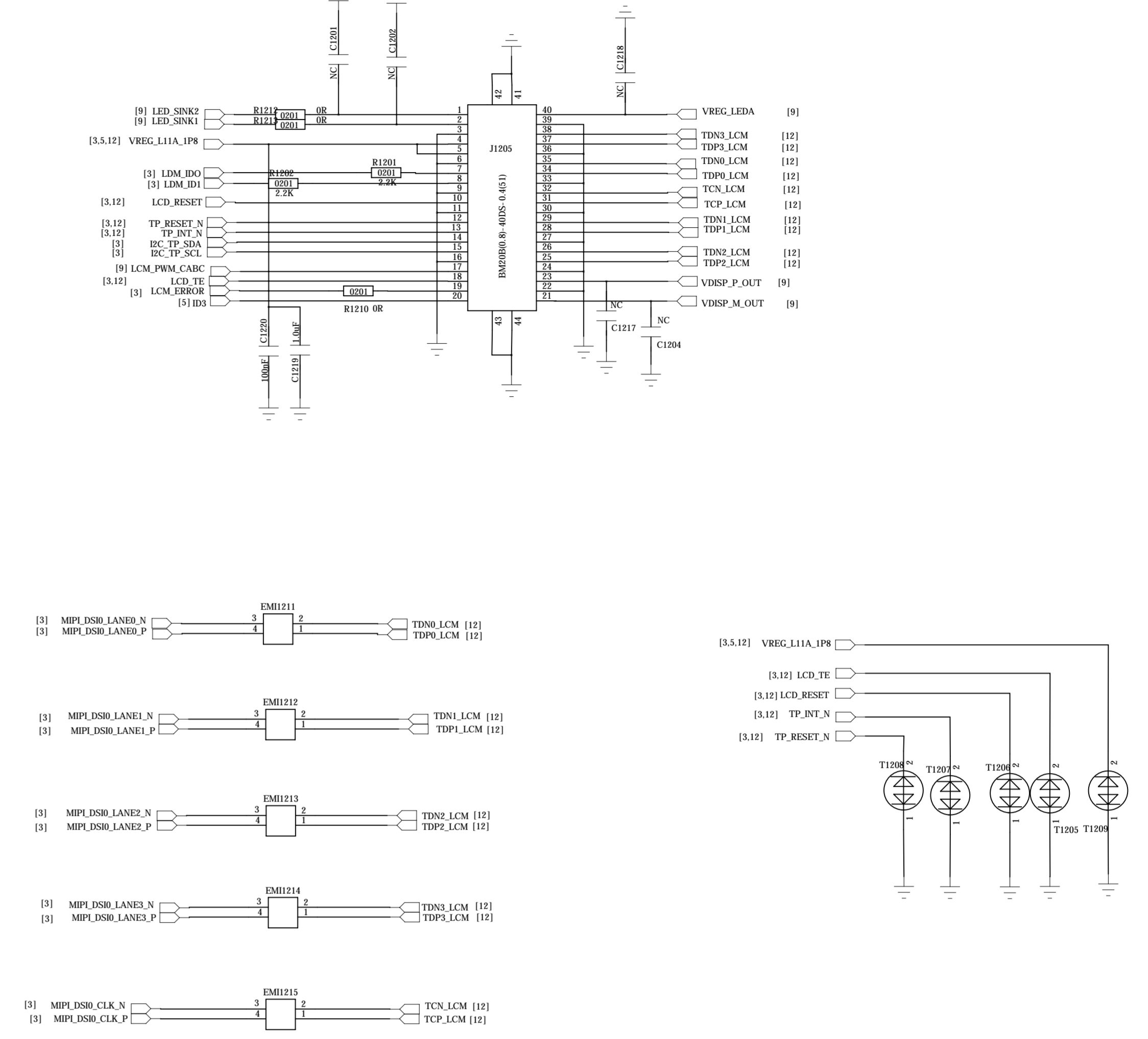

Front Camera_A

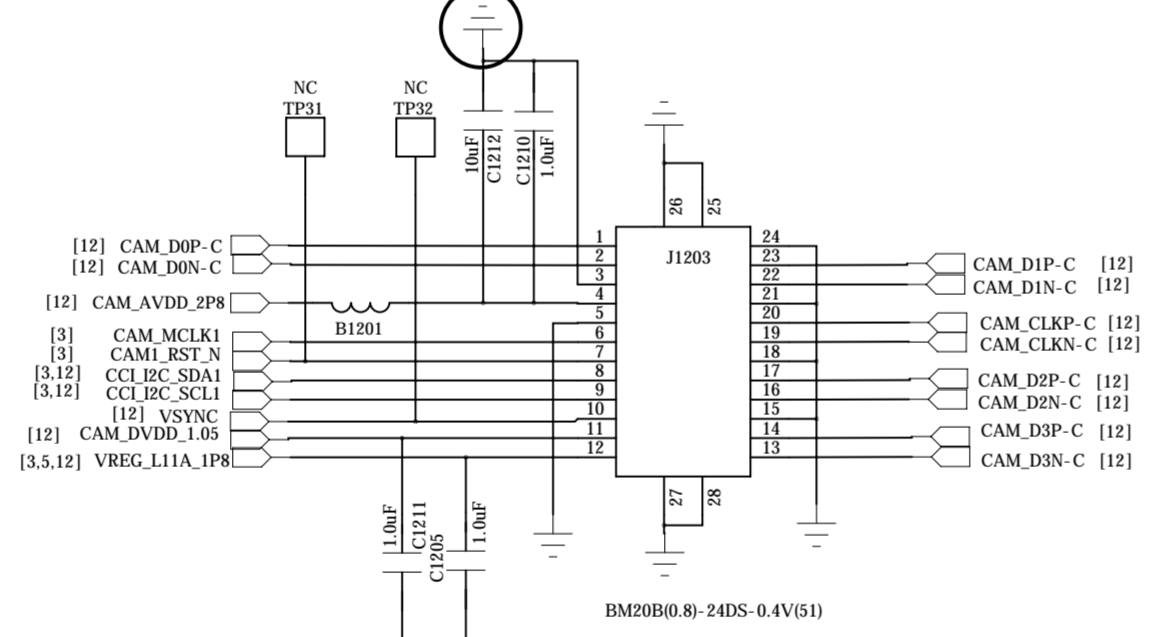
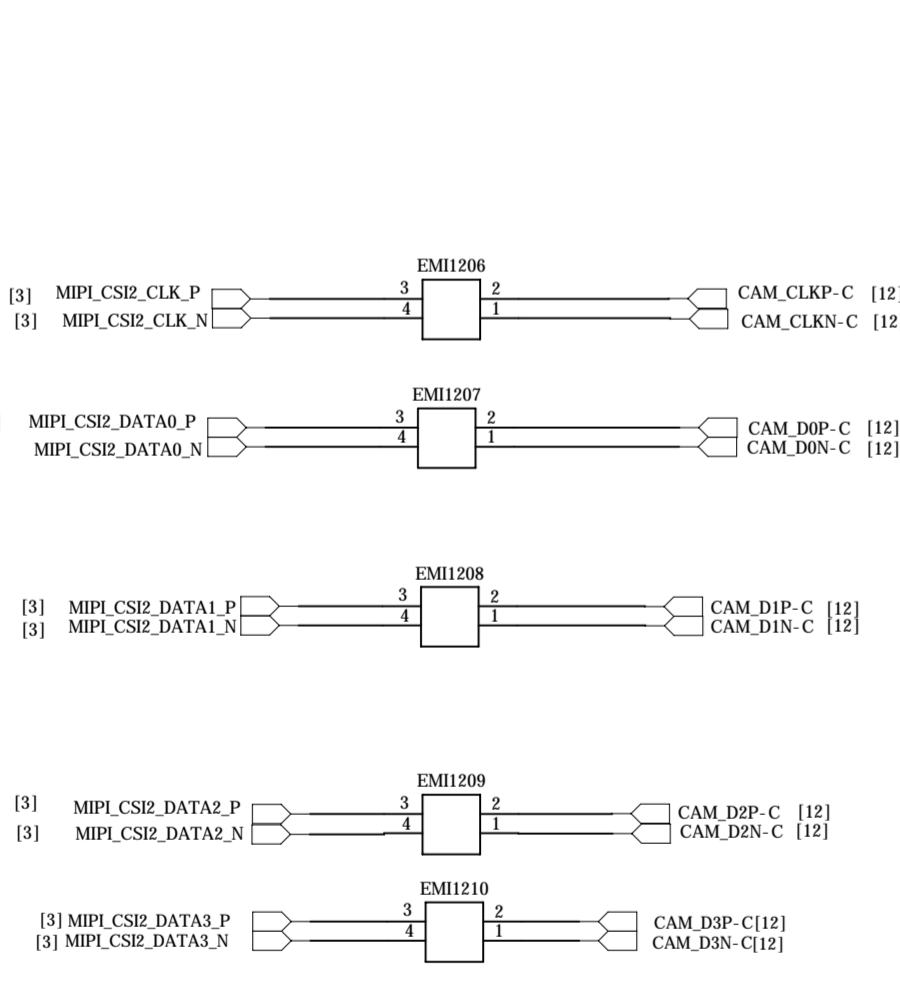

Front Camera_B

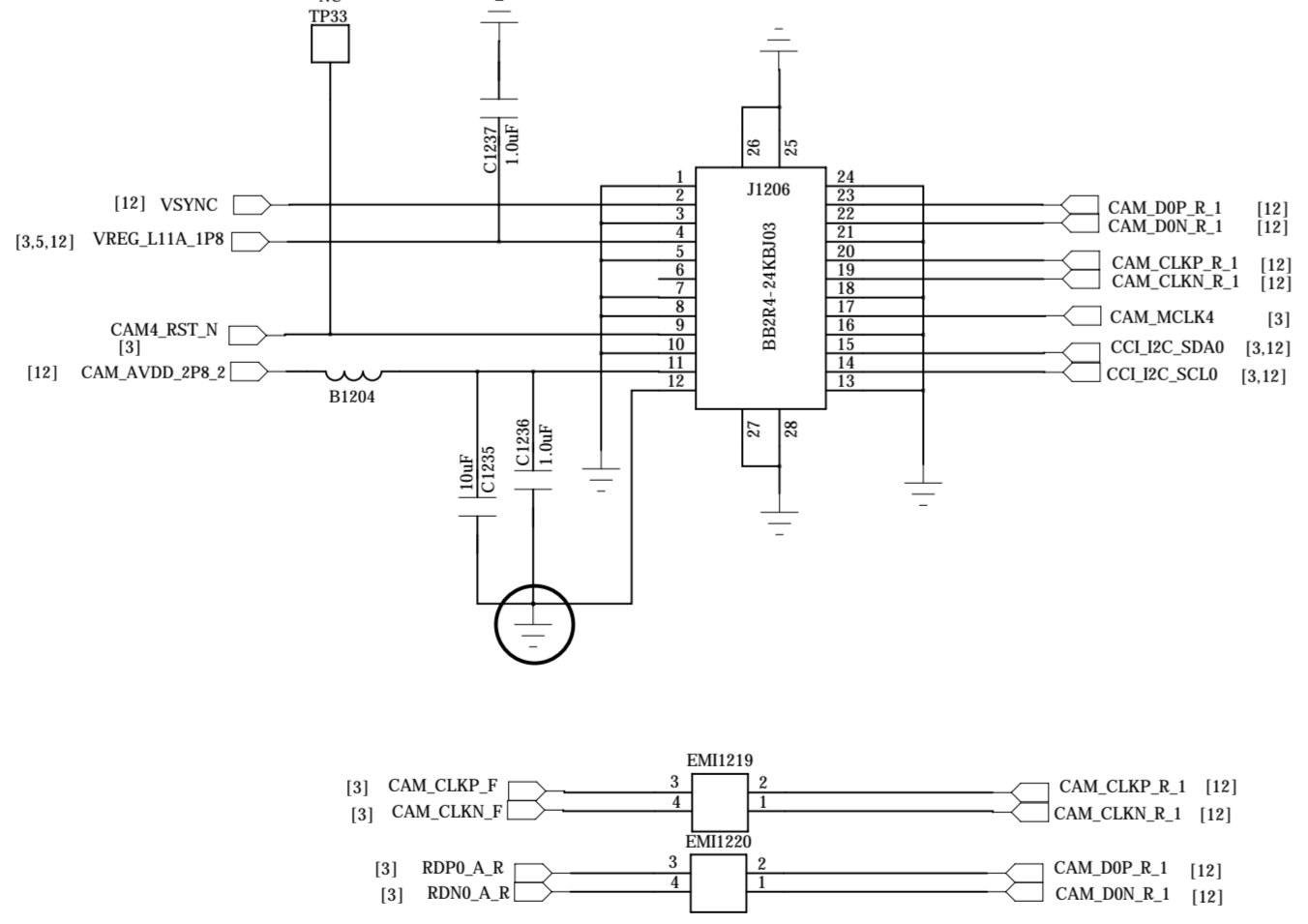
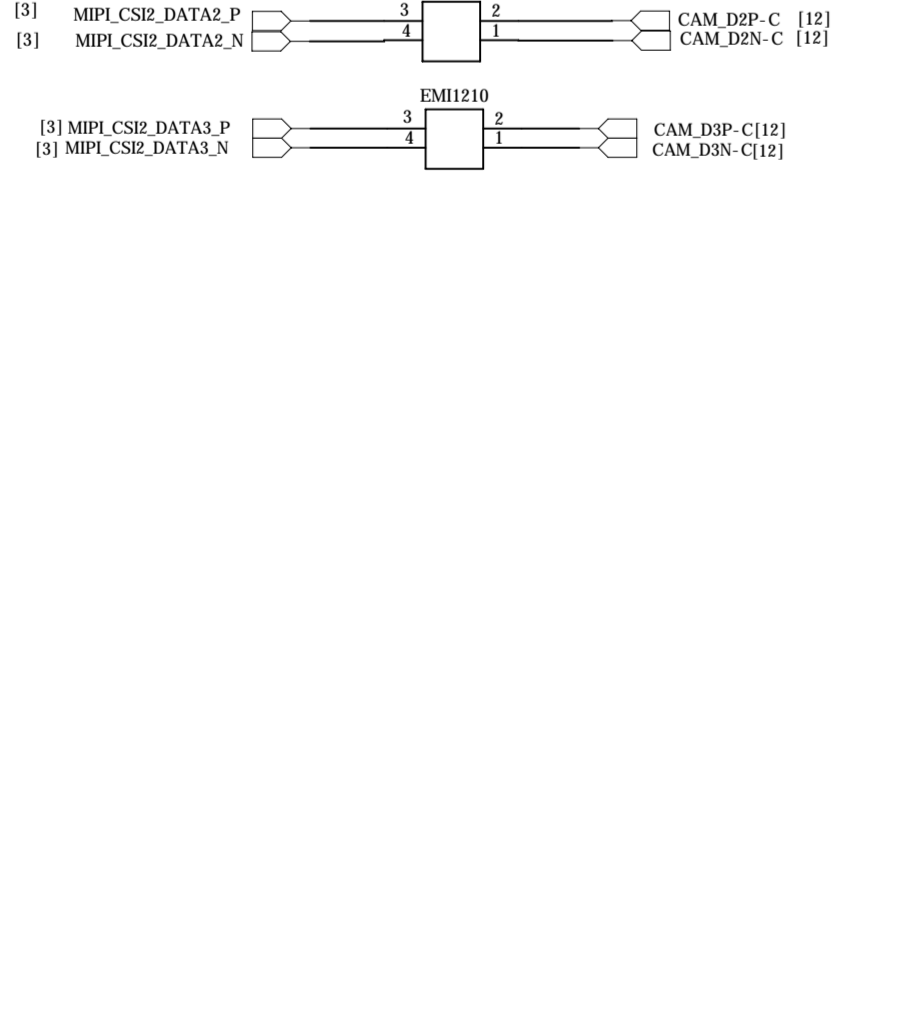

Camera Power

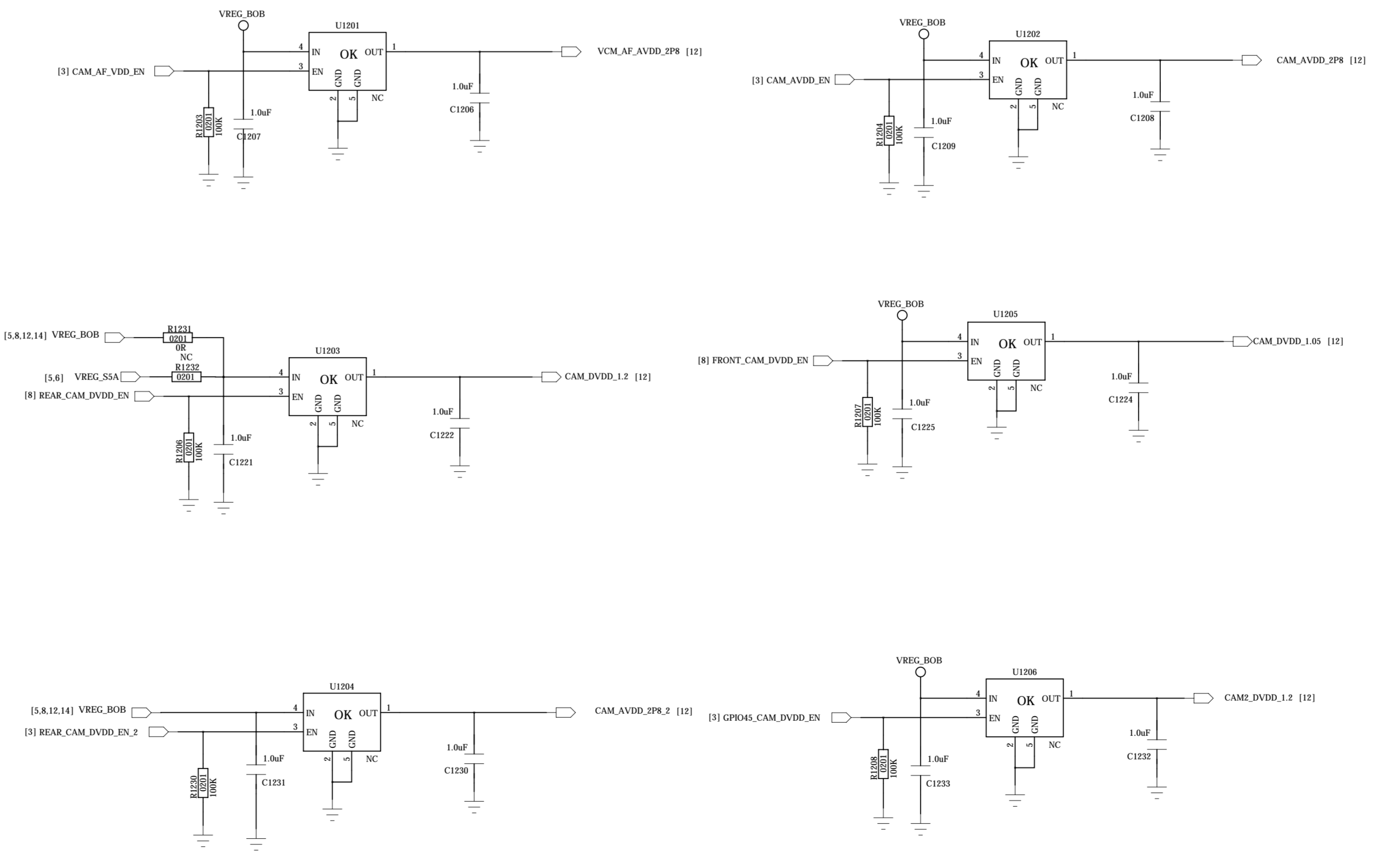

Flash Light

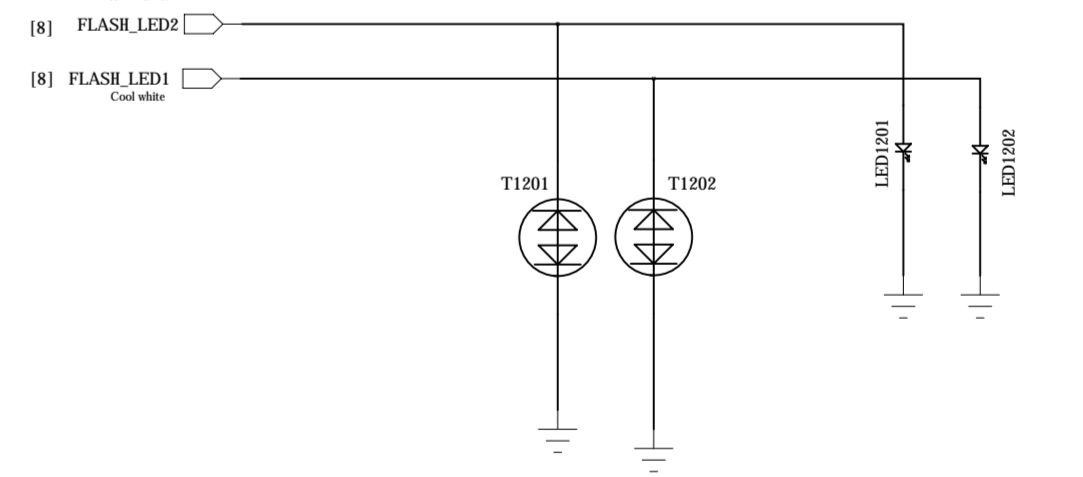

Schematic design notice of "63_PERI_CAMERA_KEYPAD" page.

Note 62-1: The VCC of I2C_0 is pulled to "VCM_AF_PMU".

Note 62-2: I2C control interface of front camera (with AF) must be assigned to I2C-2 bus when PIP/VIV feature be supported.

Note 62-3: Reserve a capacitor (27pF) on camera's MCLK and shunt it to GND to prevent GPS de-sense.

COMPANY: <Company Name>		TITLE: <Title>	
DATE: <Drawn Date>	DATE: <Checked Date>	CODE: <Code>	SIZE: A0
CHECKED: <Checked By>	DATE: <QC Date>	DRAWING NO: <Drawing Number>	
QUALITY CONTROL: <QC By>	DATE: <Release Date>	REV: <Revision>	
RELEASED: <Release By>	SCALE: <Scale>	SHEET 12 21	

REVISION RECORD			
LYR	ECO NO.	APPROVED	DATE

Battery Connector

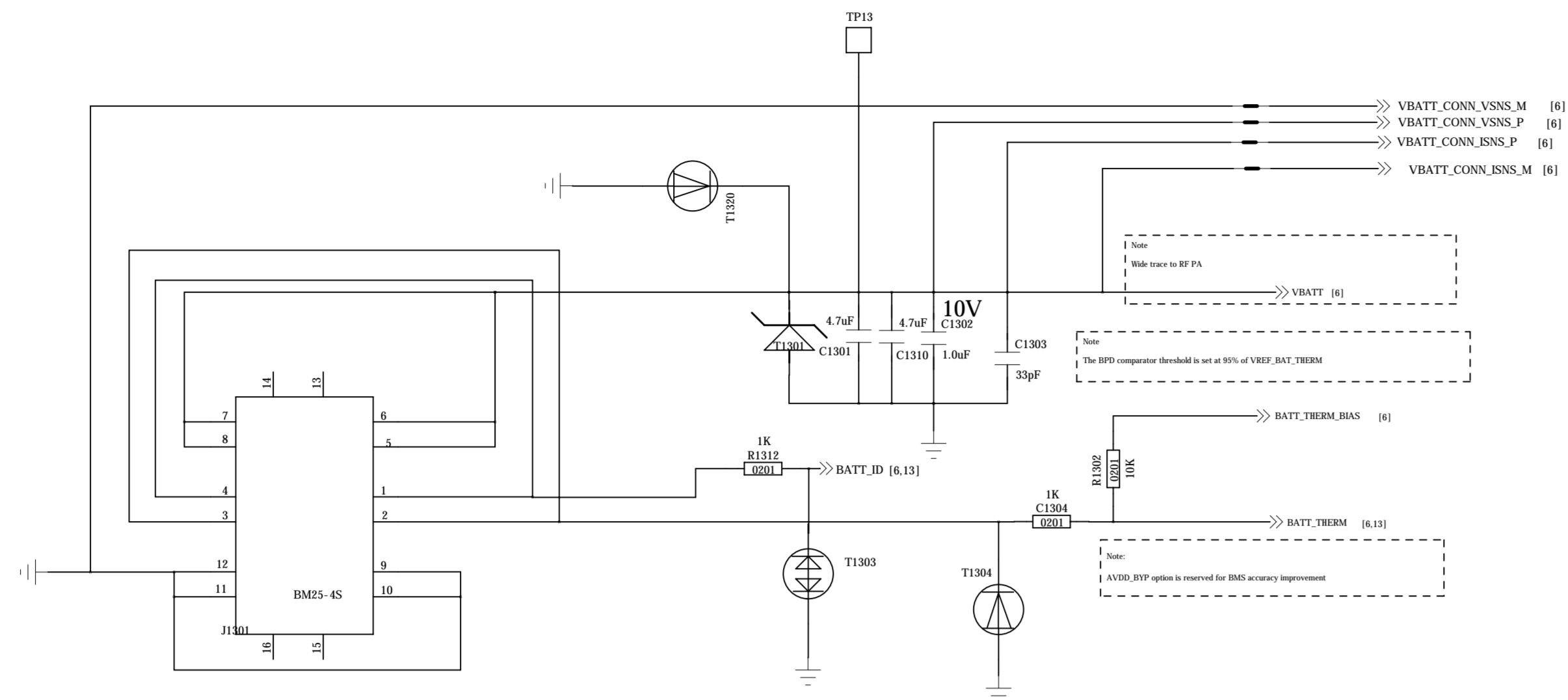

Note:
Battery ID resistor value require 20K-150K.

SUB_FPC

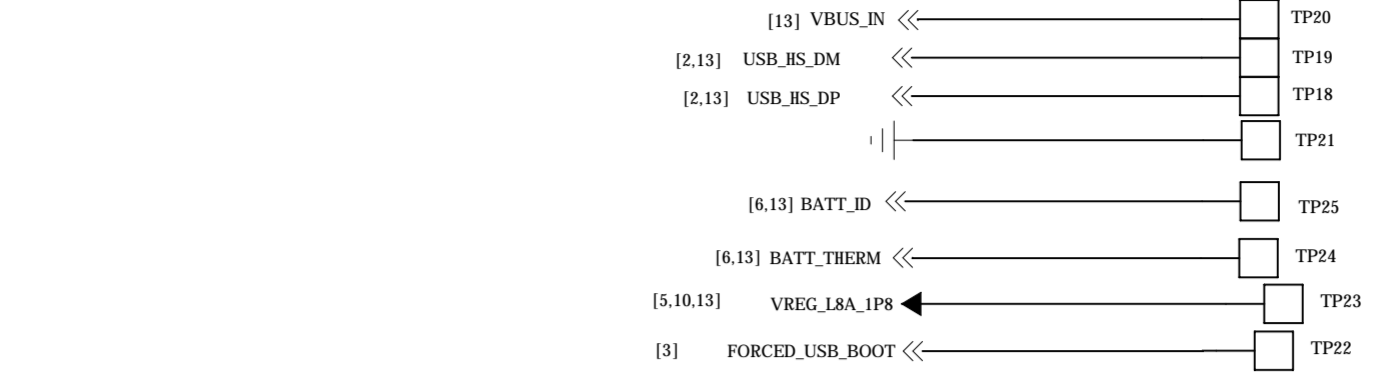
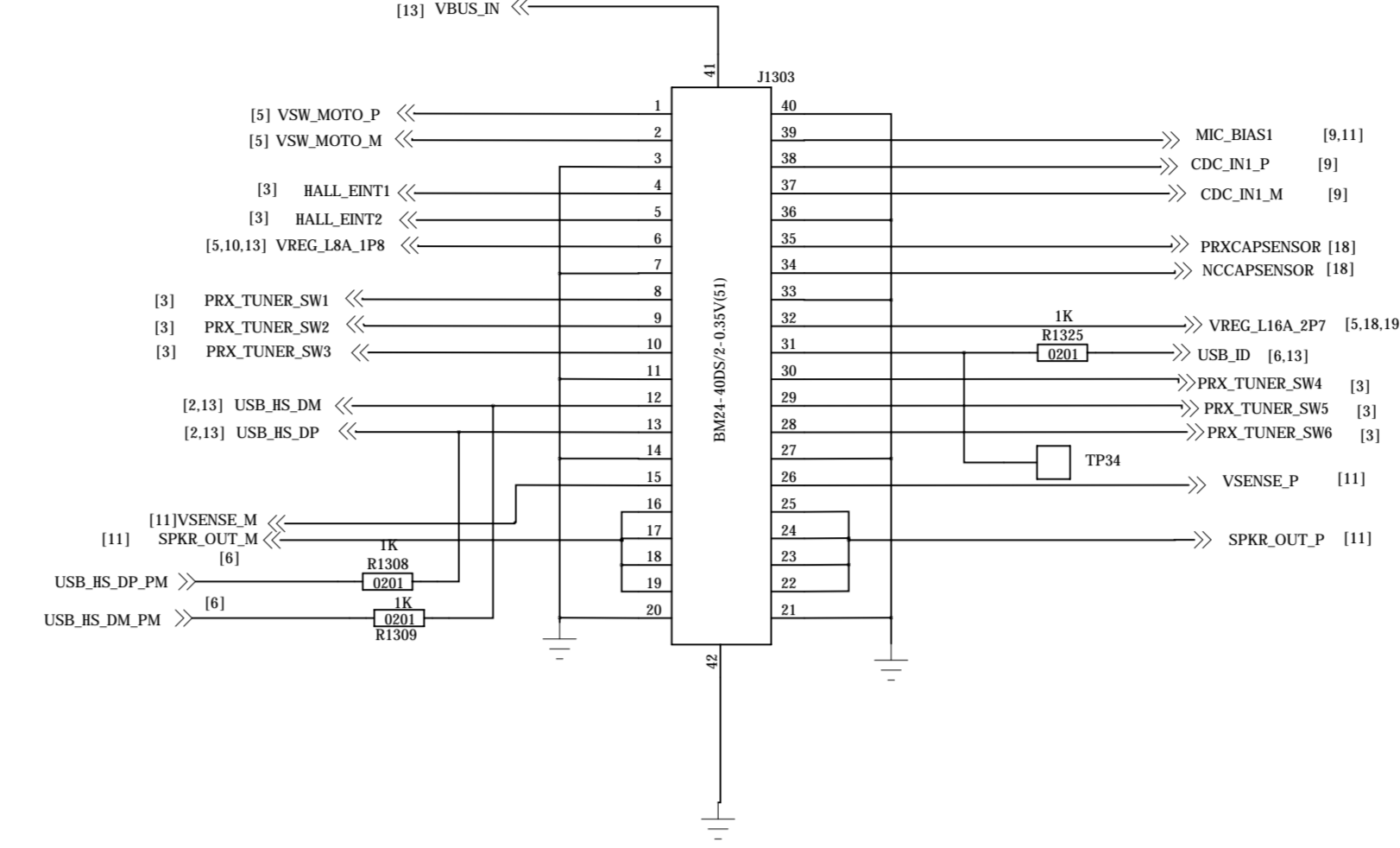

OVP

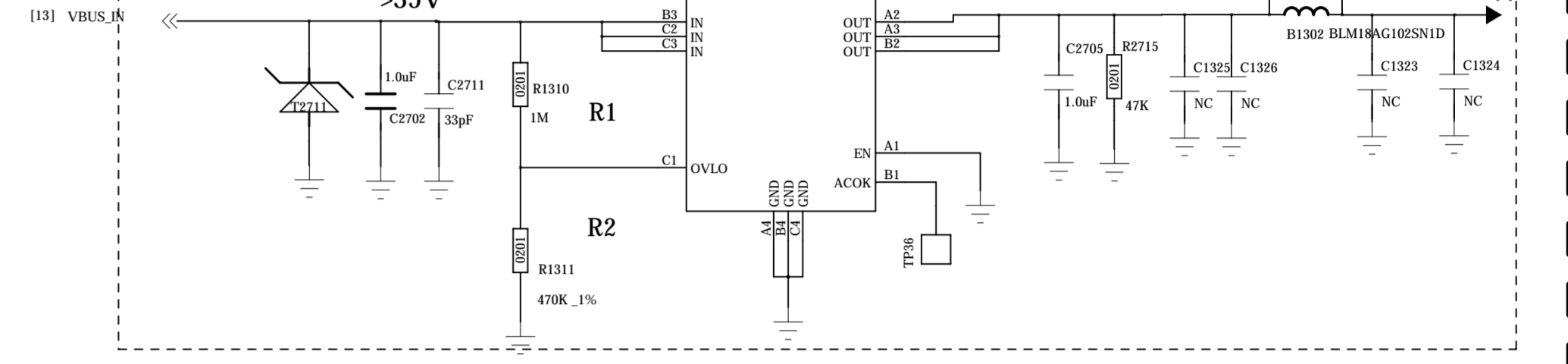

SIM&SD

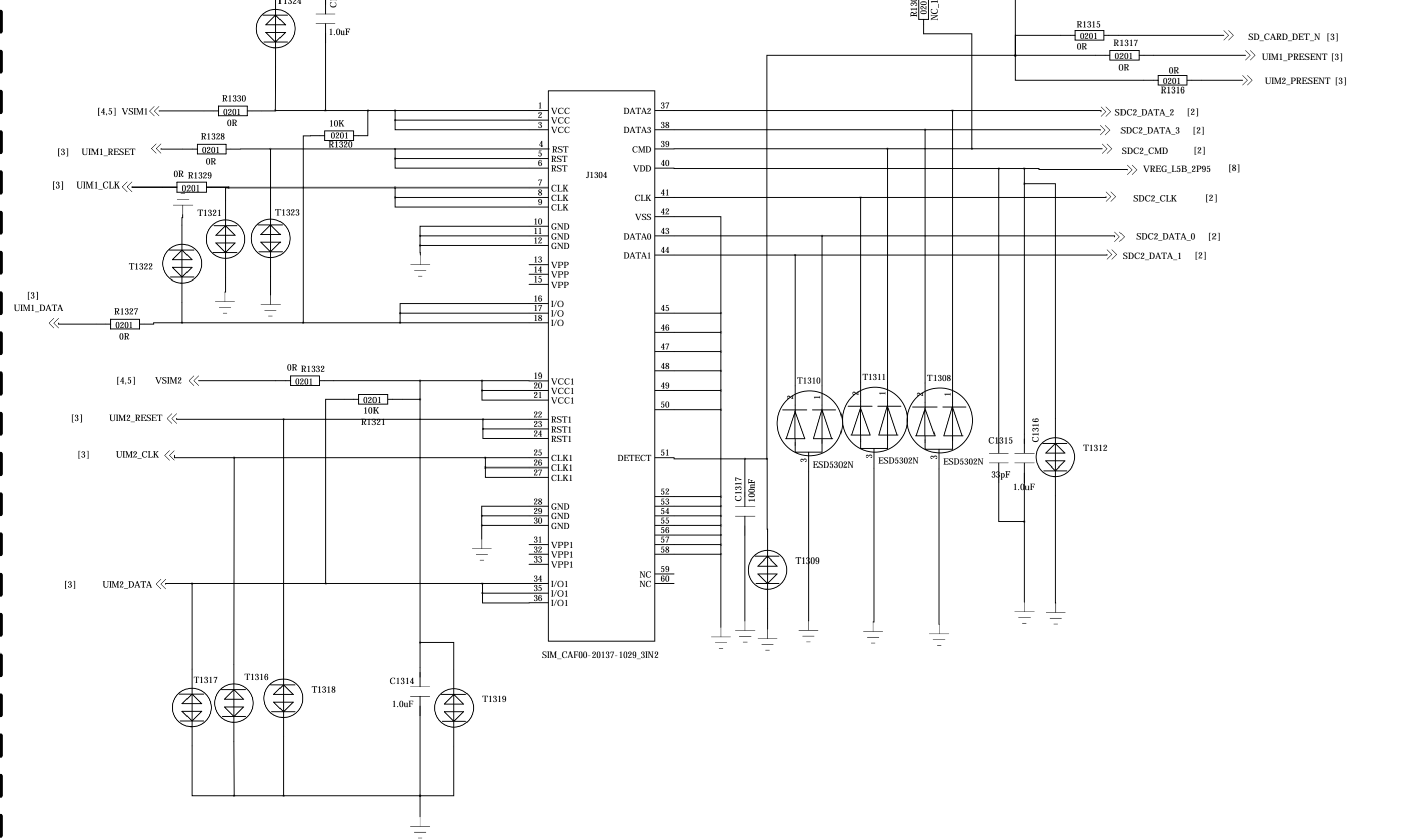

Sider Key

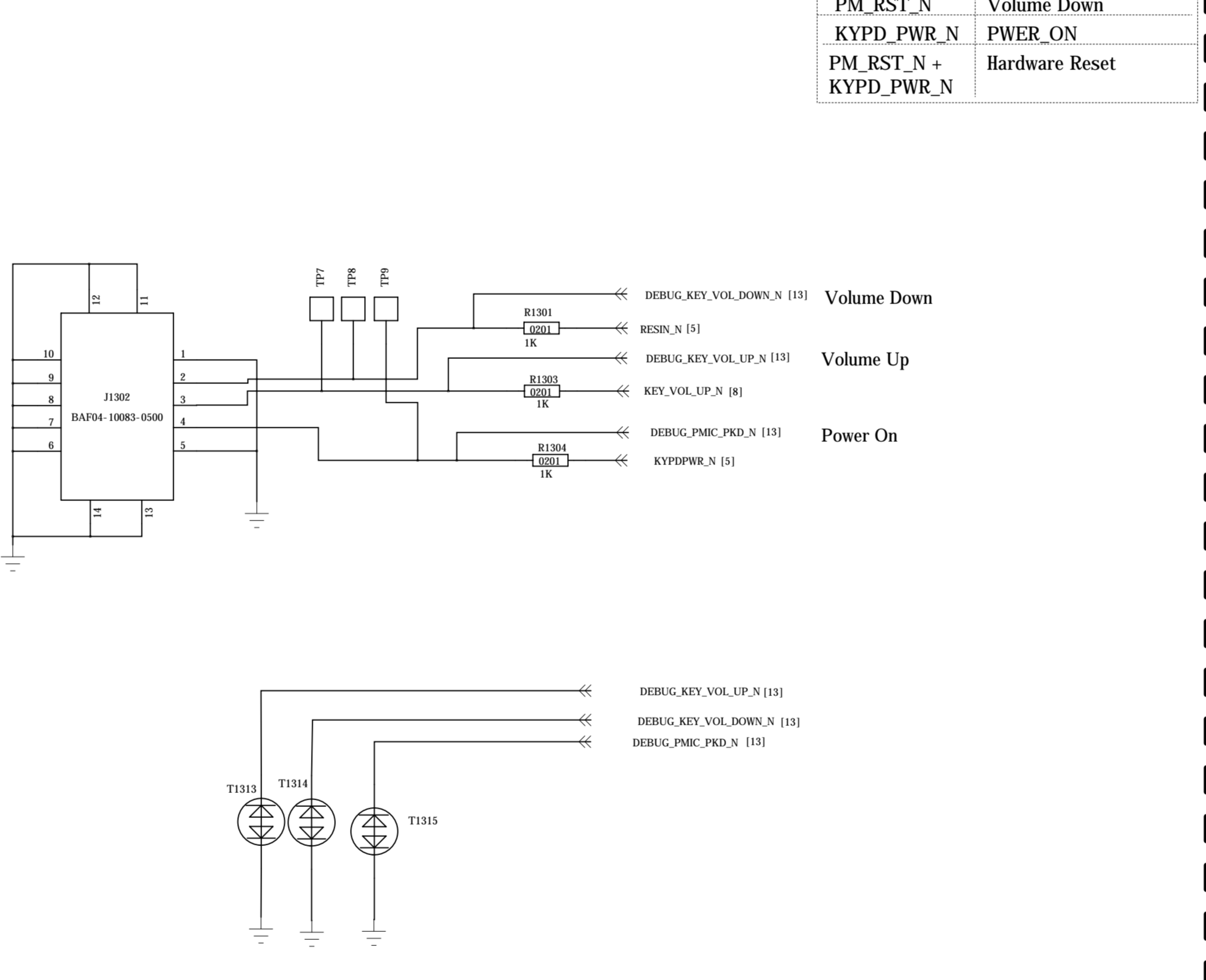

Signal	Description
KPSNS0	Volume Up
PM_RST_N	Volume Down
KYPD_PWR_N	POWER_ON
PM_RST_N + KYPD_PWR_N	Hardware Reset

SUB_LED

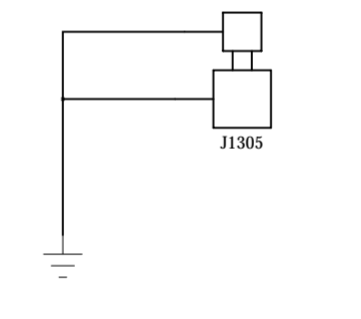

COMPANY: <Company Name>		TITLE: <Title>	
DRAWN: <Drawn By>	DATE: <Drawn Date>	CODE: <Code>	SIZE: A0
CHECKED: <Checked By>	DATE: <Checked Date>	DRAWING NO: <Drawing Number>	
QUALITY CONTROL: <QC By>	DATE: <QC Date>	REV: <Revision>	
RELEASED: <Released By>	DATE: <Release Date>	SCALE: <Scale>	SHEET: 18 / 21

REVISION RECORD			
LT#	REV. NO.	APPROVED:	DATE:

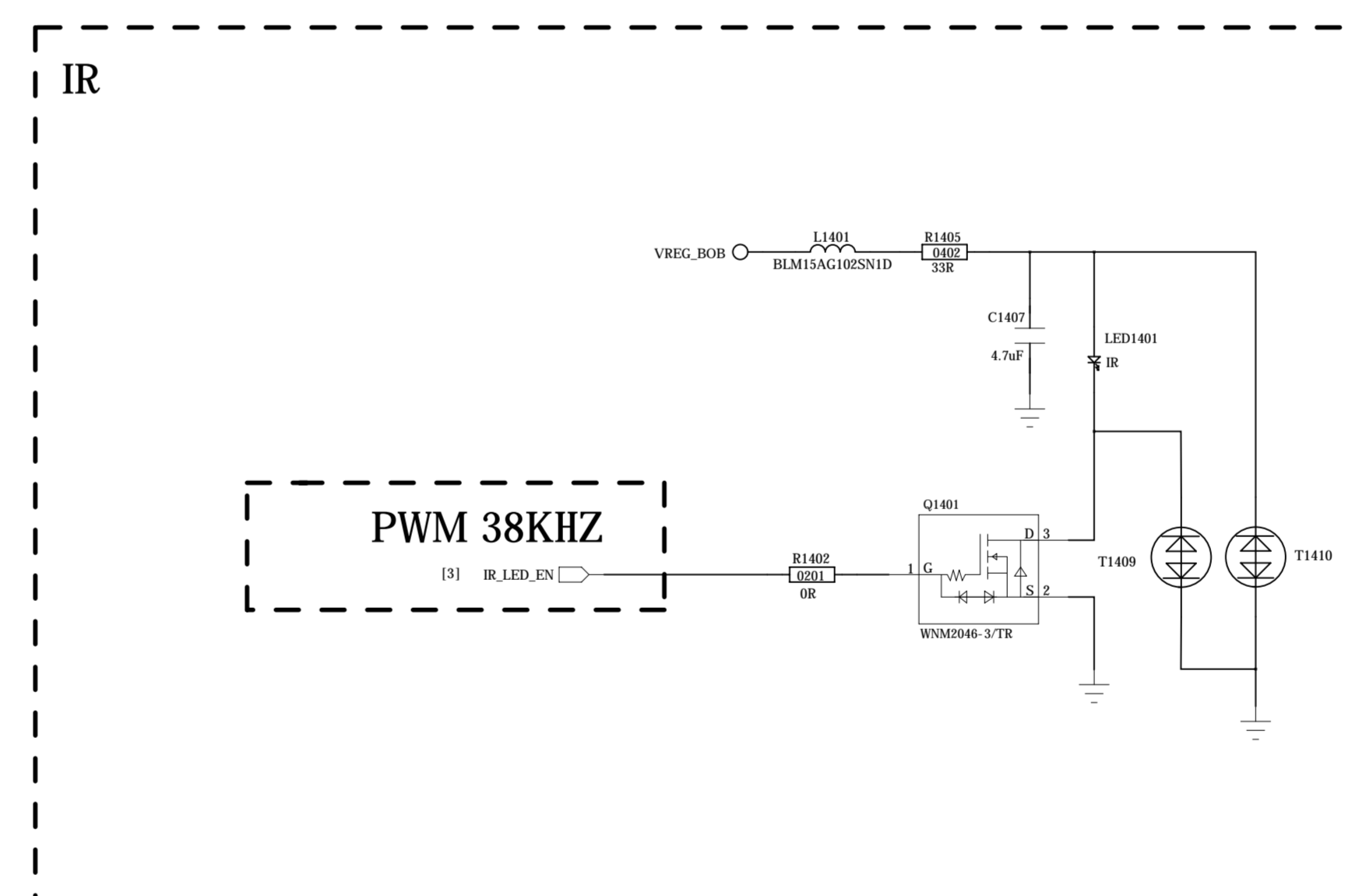
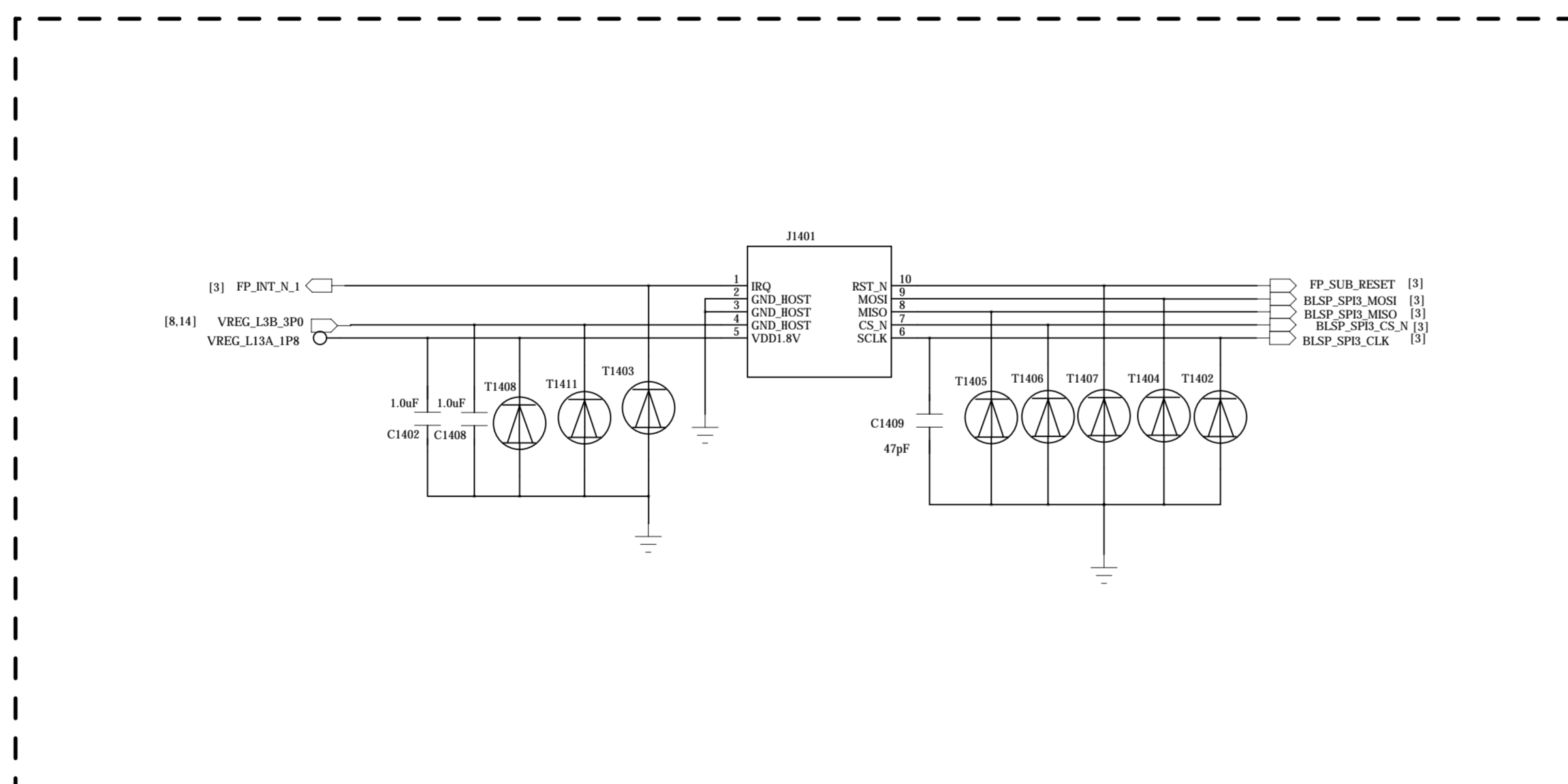
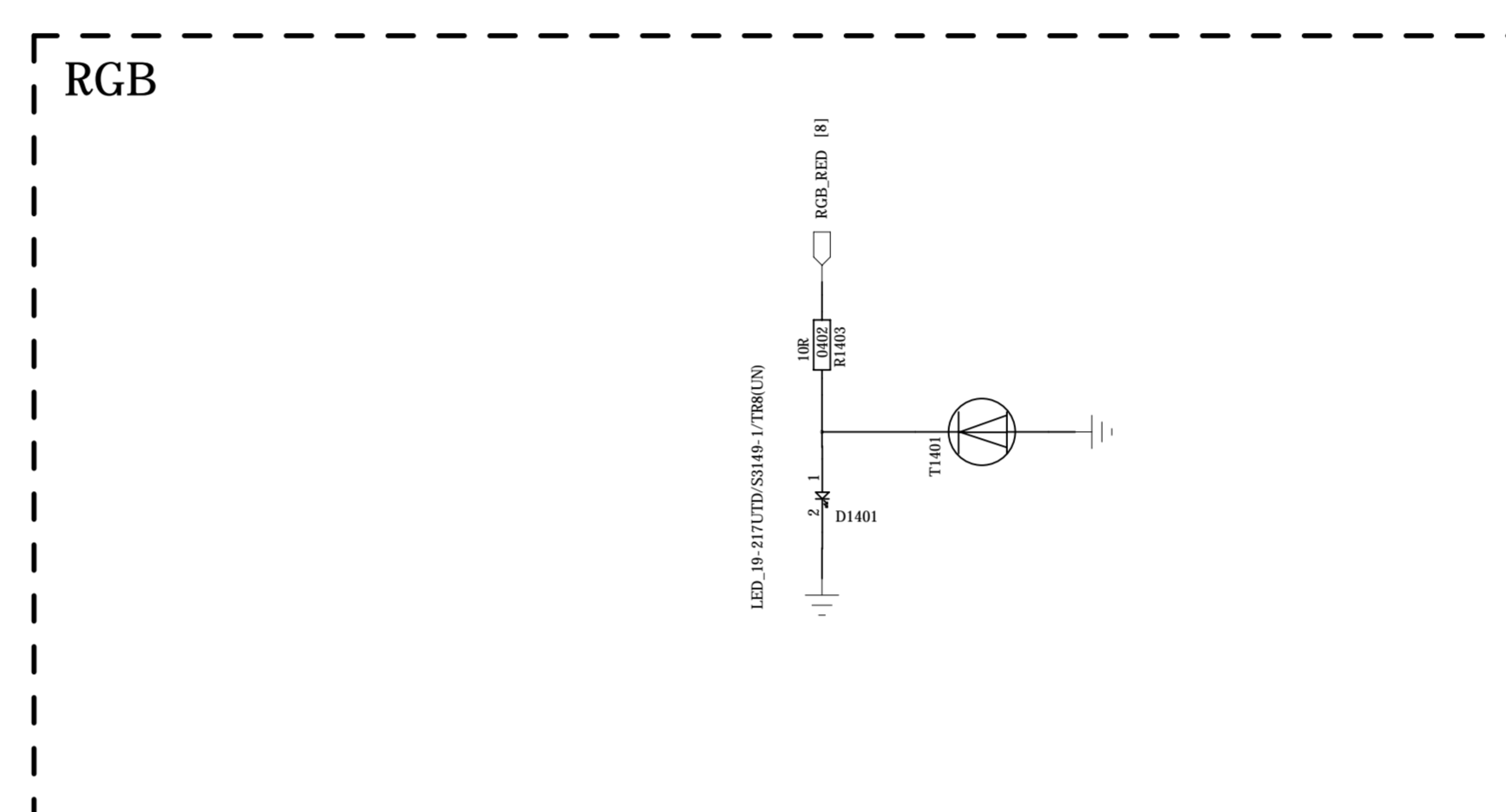
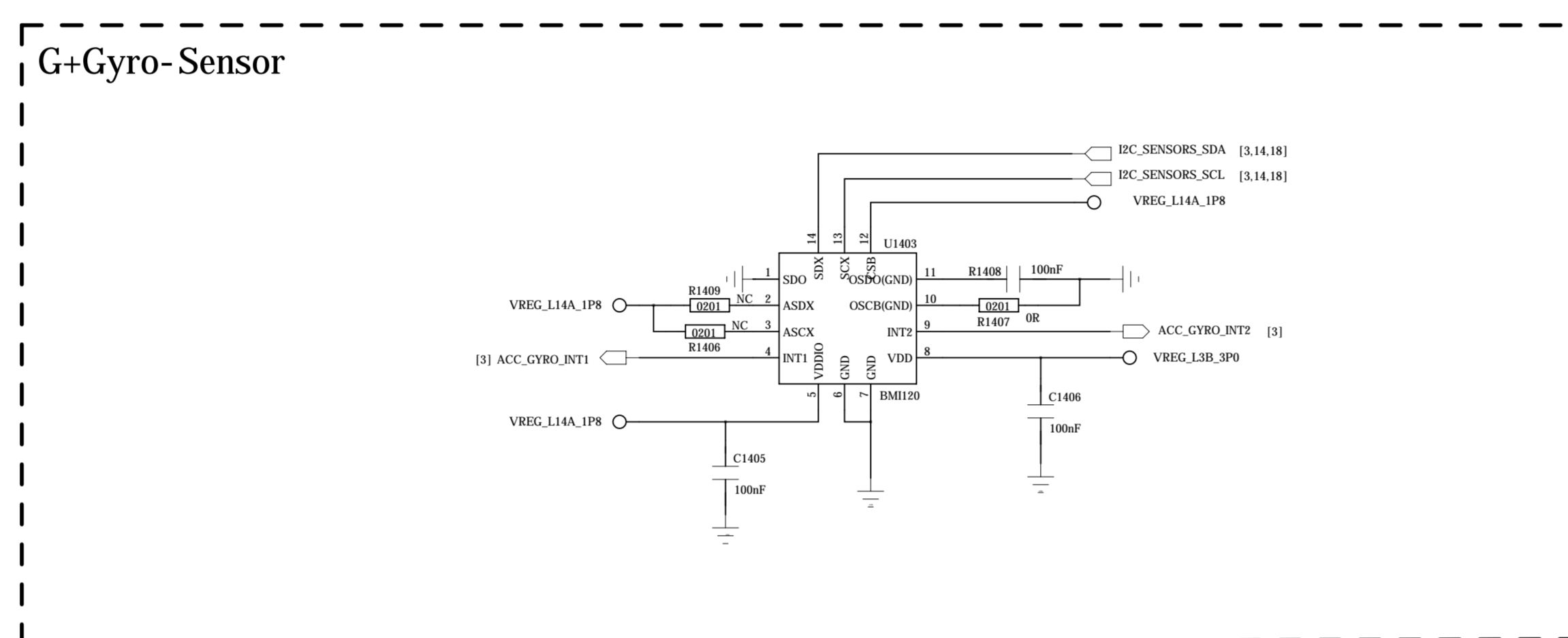
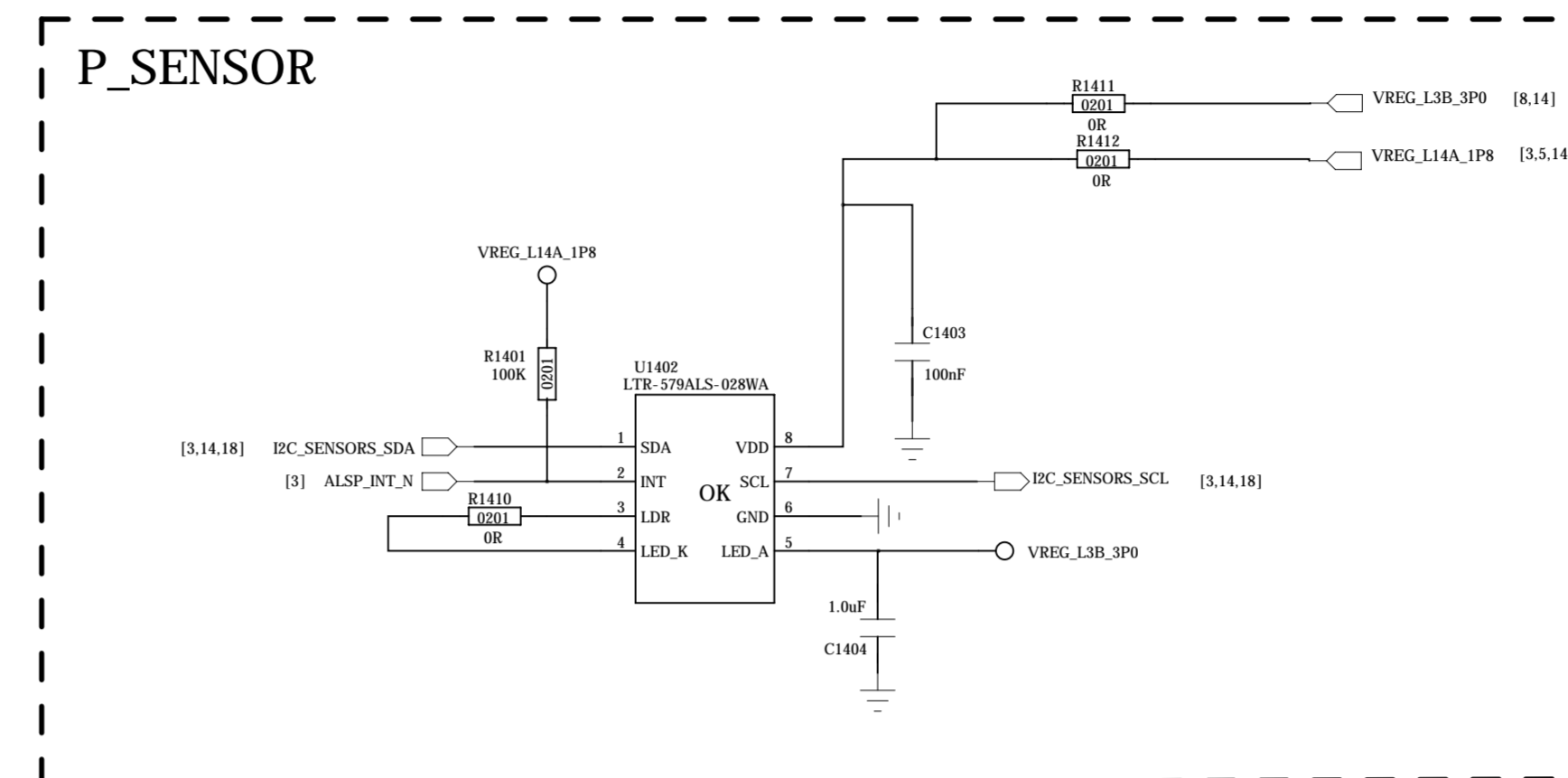
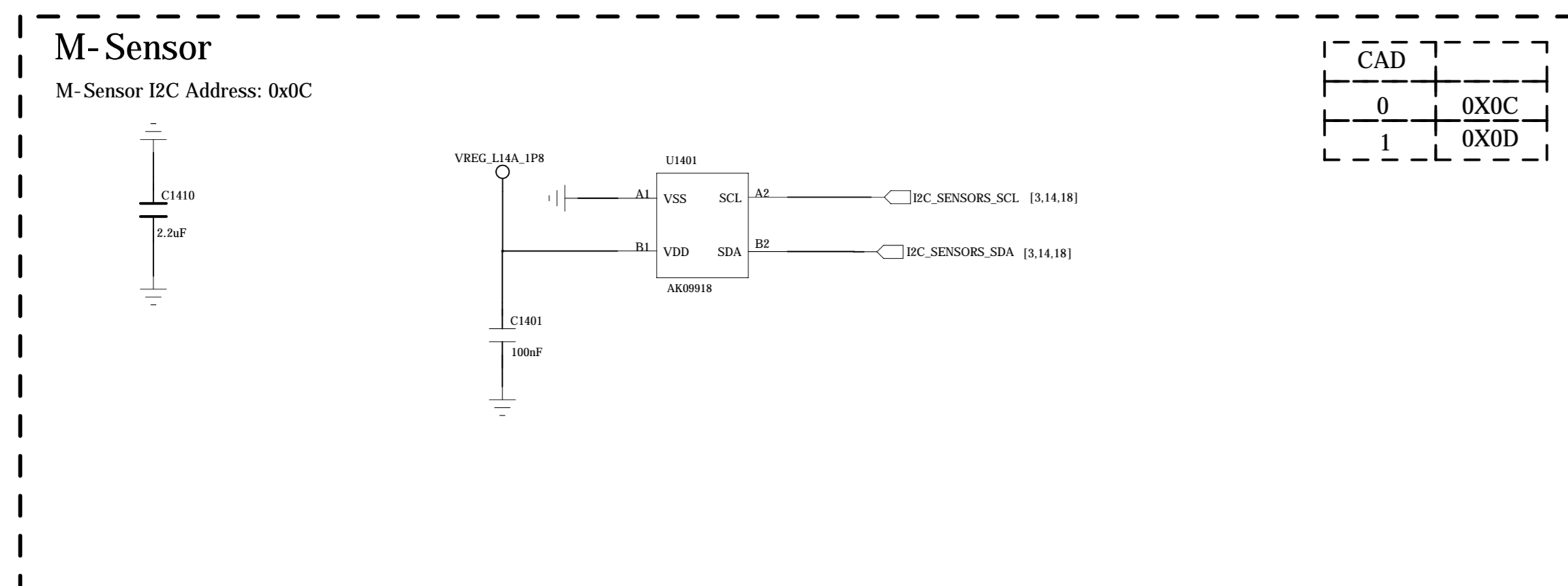

DRAWN: <Drawn By>		DATE: <Drawn Date>		COMPANY: <Company Name>			
CHECKED: <Checked By>		DATE: <Checked Date>		TITLE: <Title>			
QUALITY CONTROL: <QC By>		DATE: <QC Date>		CODE: <Code>	SIZE: A0	DRAWING NO: <Drawing Number>	REV: <Revision>
RELEASED: <Released By>		DATE: <Release Date>		SCALE: <Scale>		SHEET 14 21	

REVISION RECORD			
LT#	ECO NO.	APPROVED	DATE

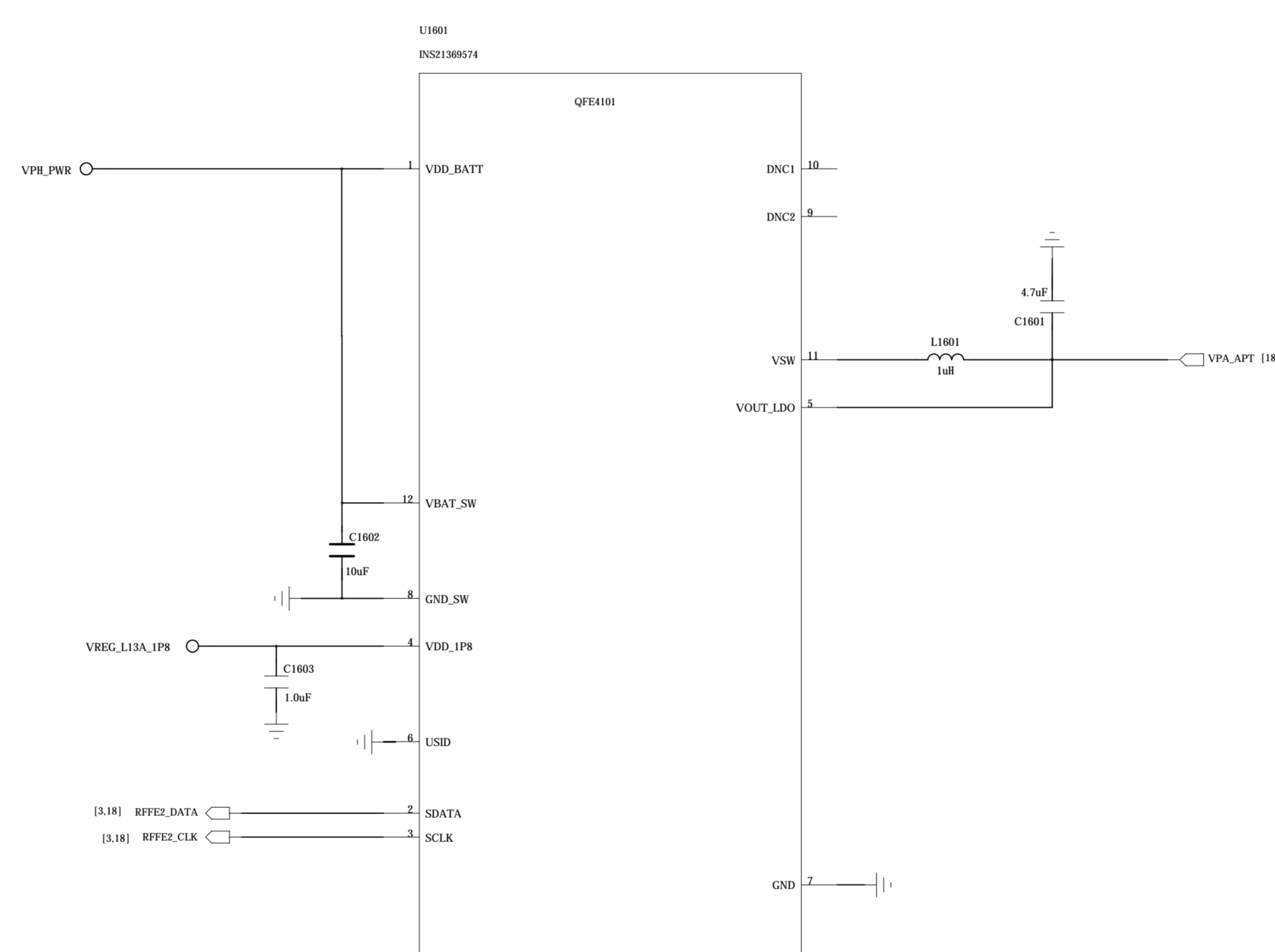

DRAWN: <Drawn By>		DATE: <Drawn Date>		COMPANY: <Company Name>			
CHECKED: <Checked By>		DATE: <Checked Date>		TITLE: <Title>			
QUALITY CONTROL: <QC By>		DATE: <QC Date>		CODE: <Code>	SIZE: A0	DRAWING NO: <Drawing Number>	REV: <Revision>
RELEASED: <Released By>		DATE: <Release Date>		SCALE: <Scale>		SHEET 10 21	

REVISION RECORD			
LT#	REV NO	APPROVED	DATE

TRX_B7

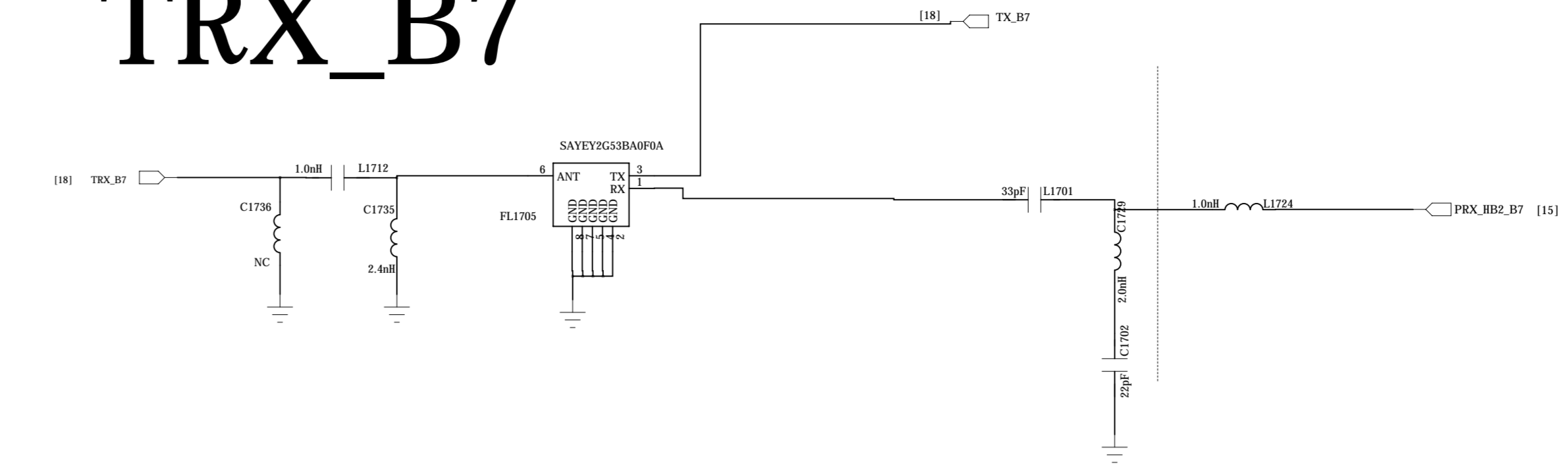

TRX_B1

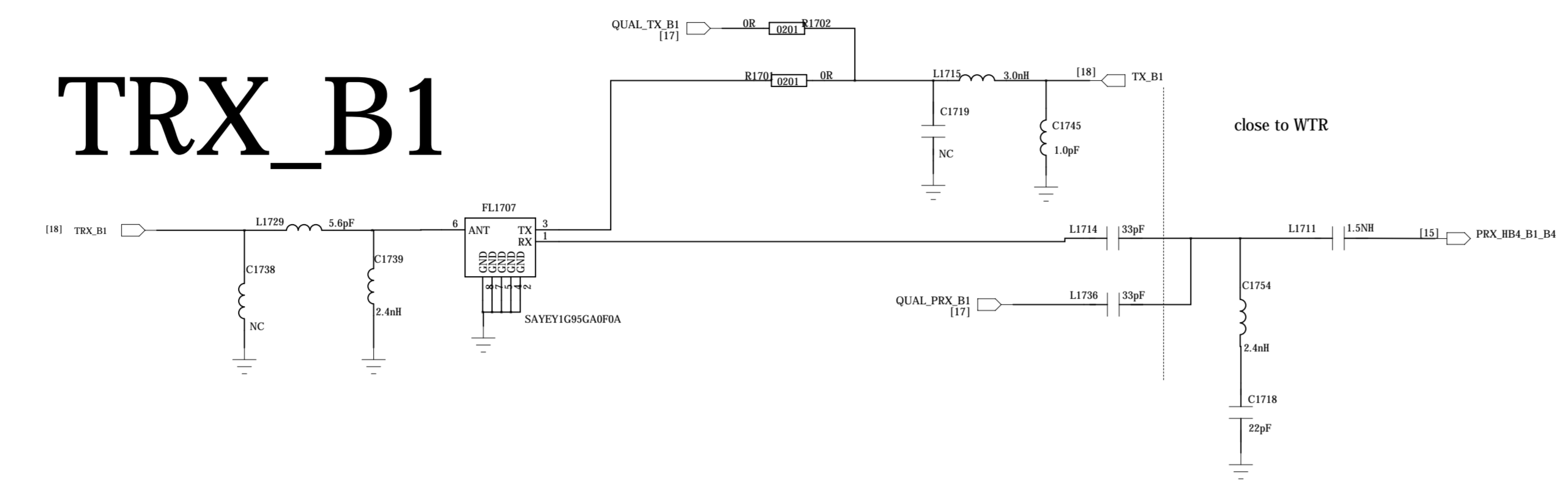

TRX_B8

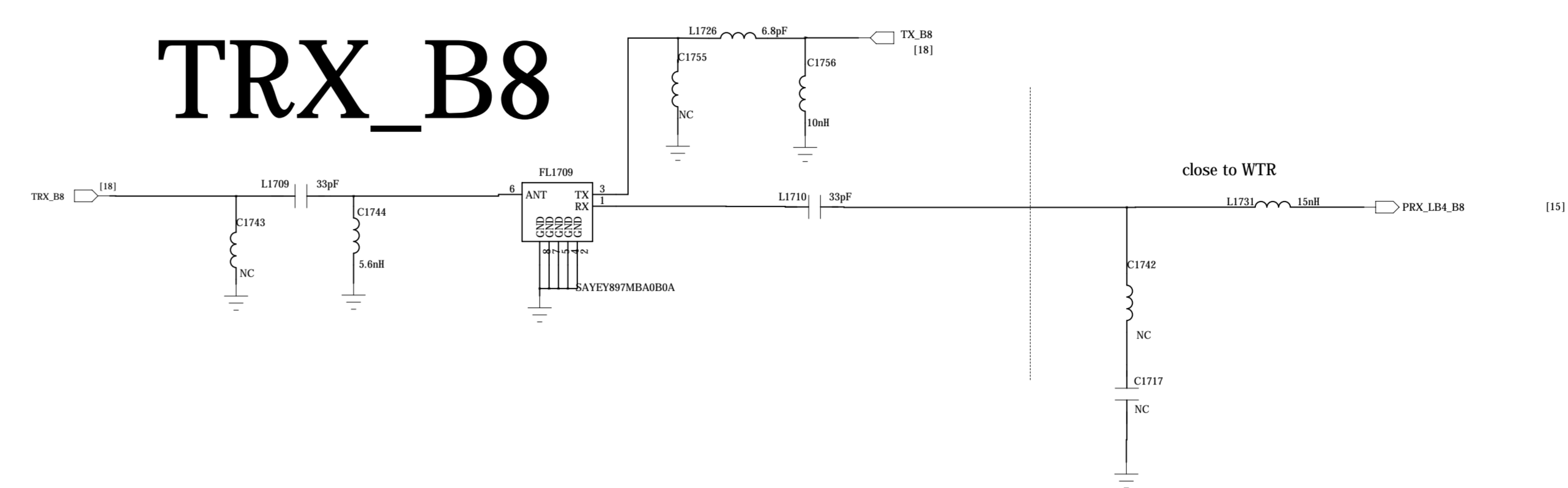

RF1630	
MODE	VC1
RFIN--RF1	0
RFIN--RF2	1

TRX_B1_B3_B4

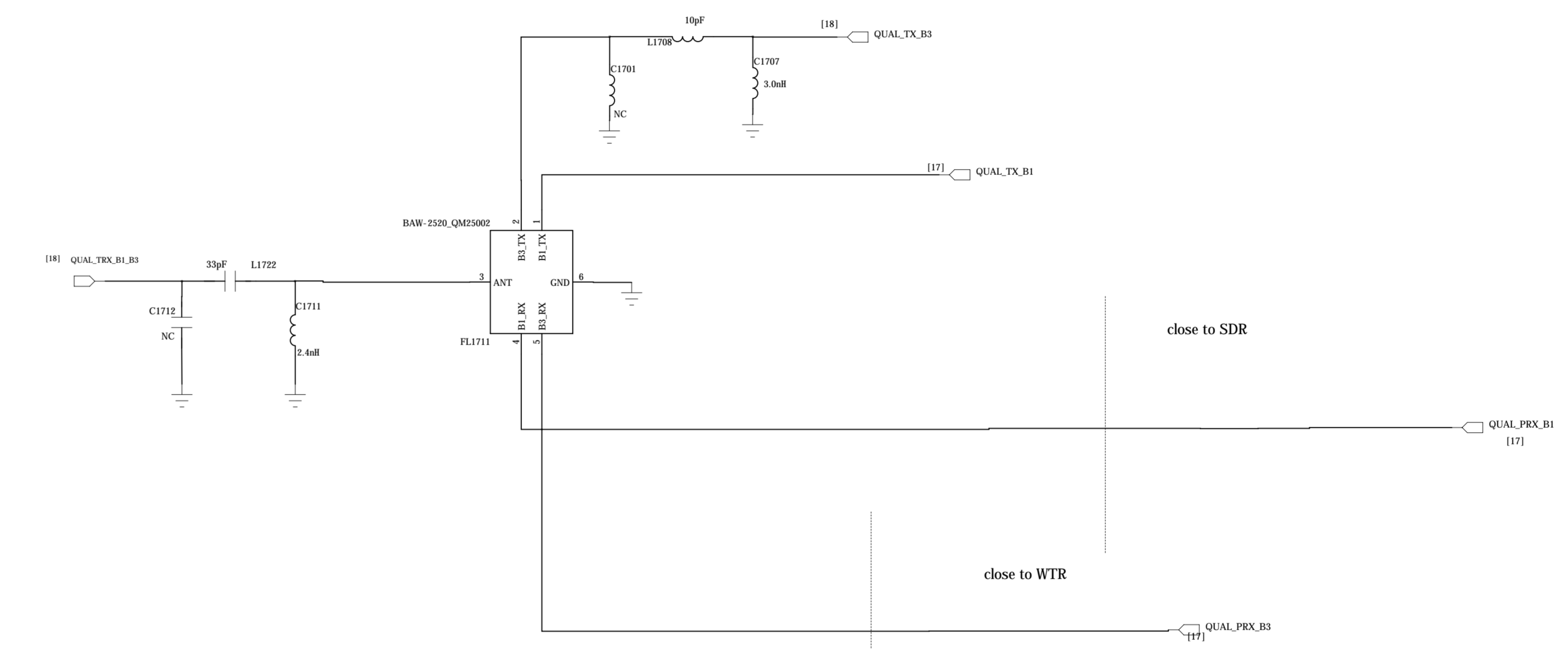

TRX_B2

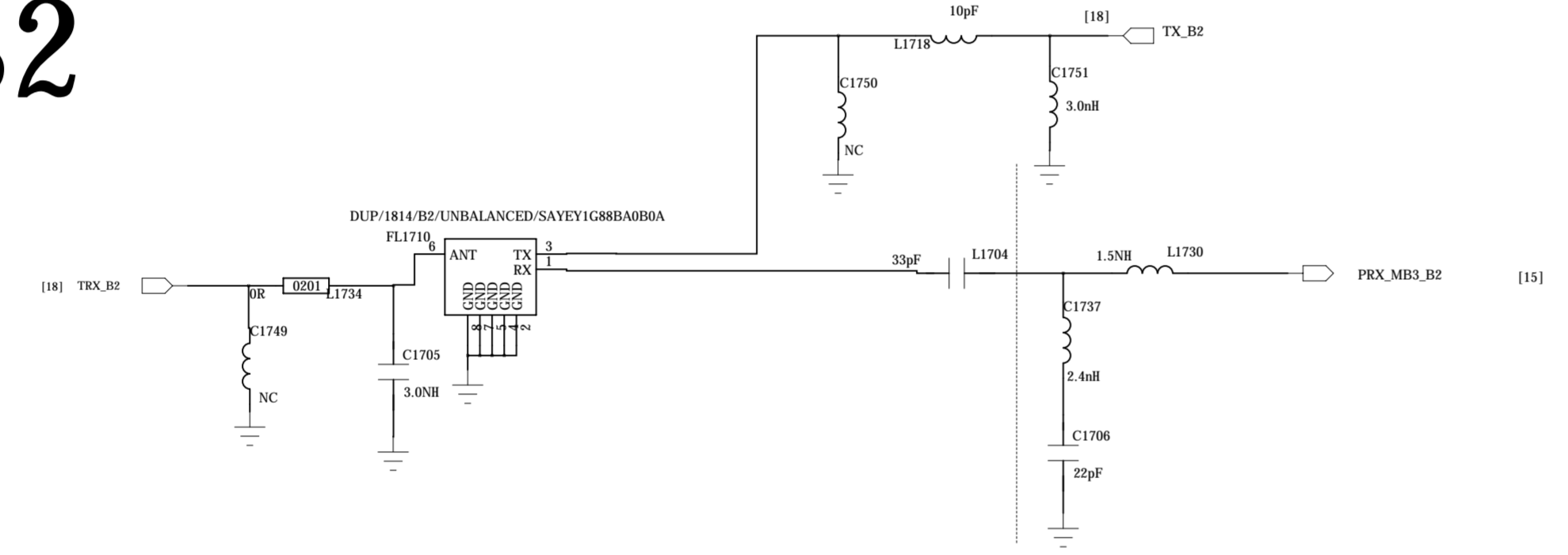

TRX_B3

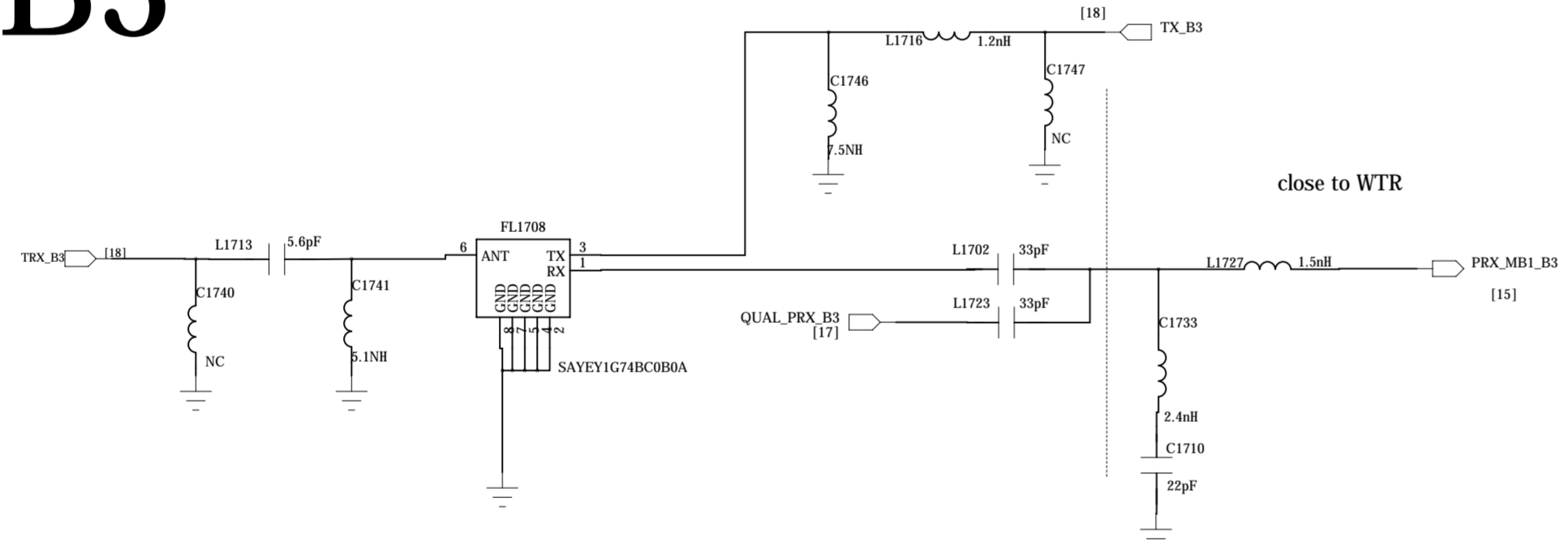

TRX_TDS_B34_B39

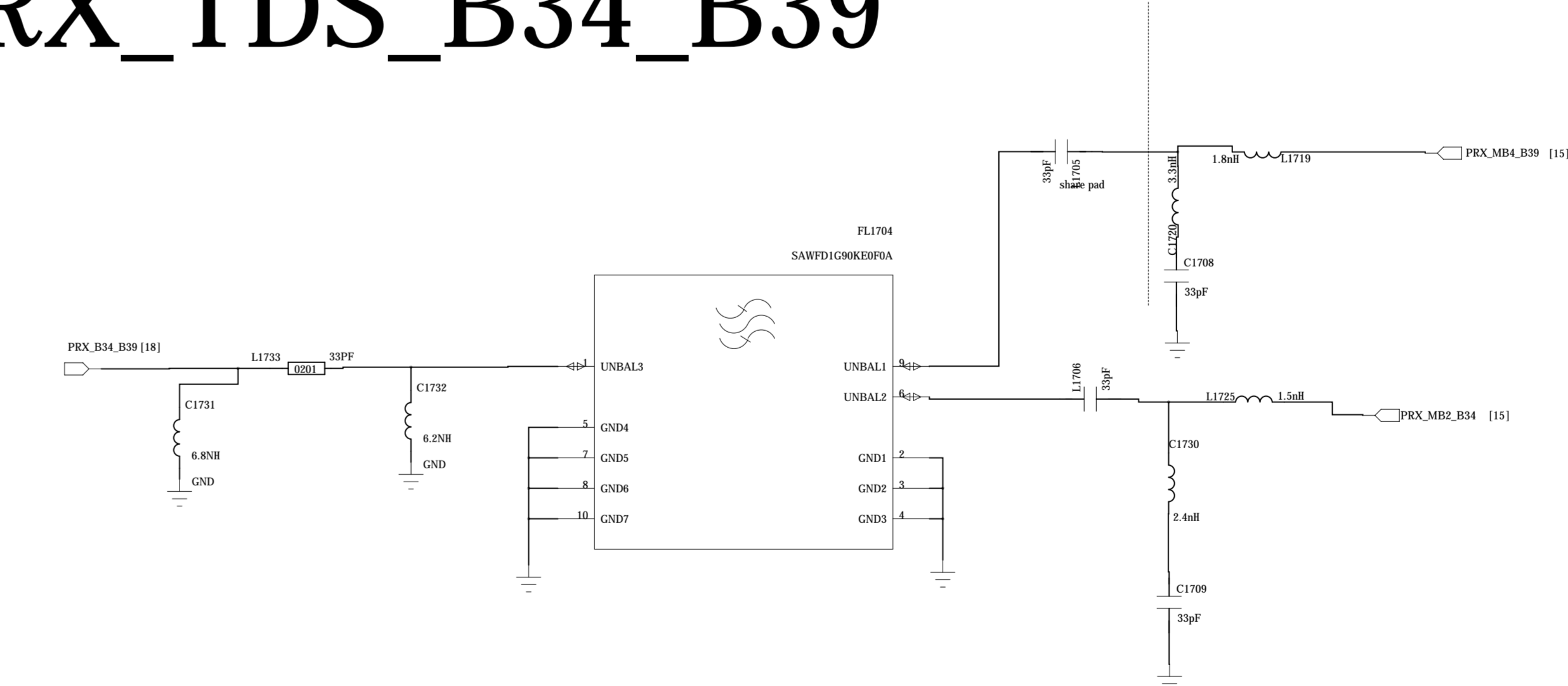

TRX_B5

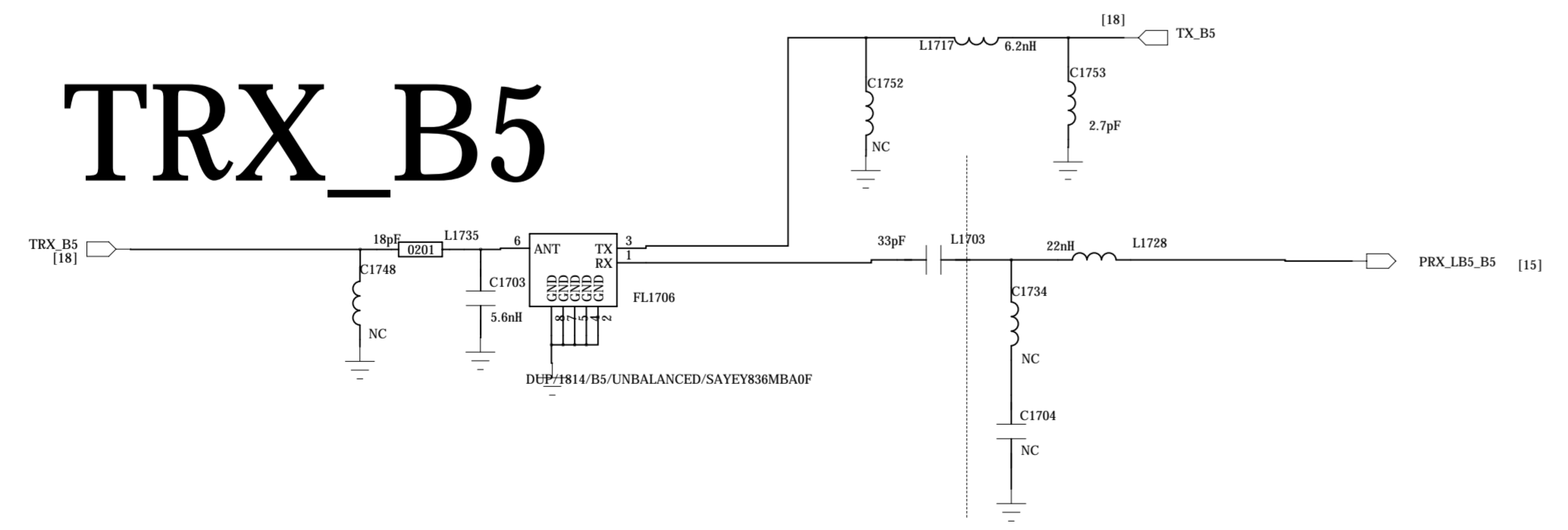

TRX_B28A

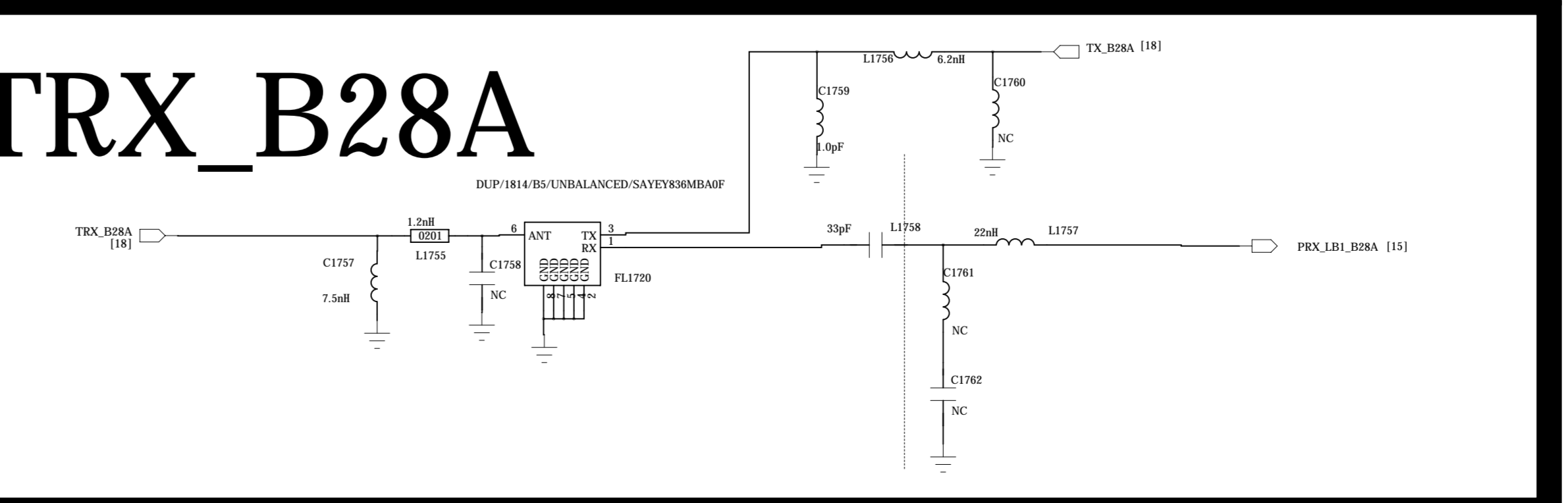

TRX_B20/B28B Shared with B34_39_RX

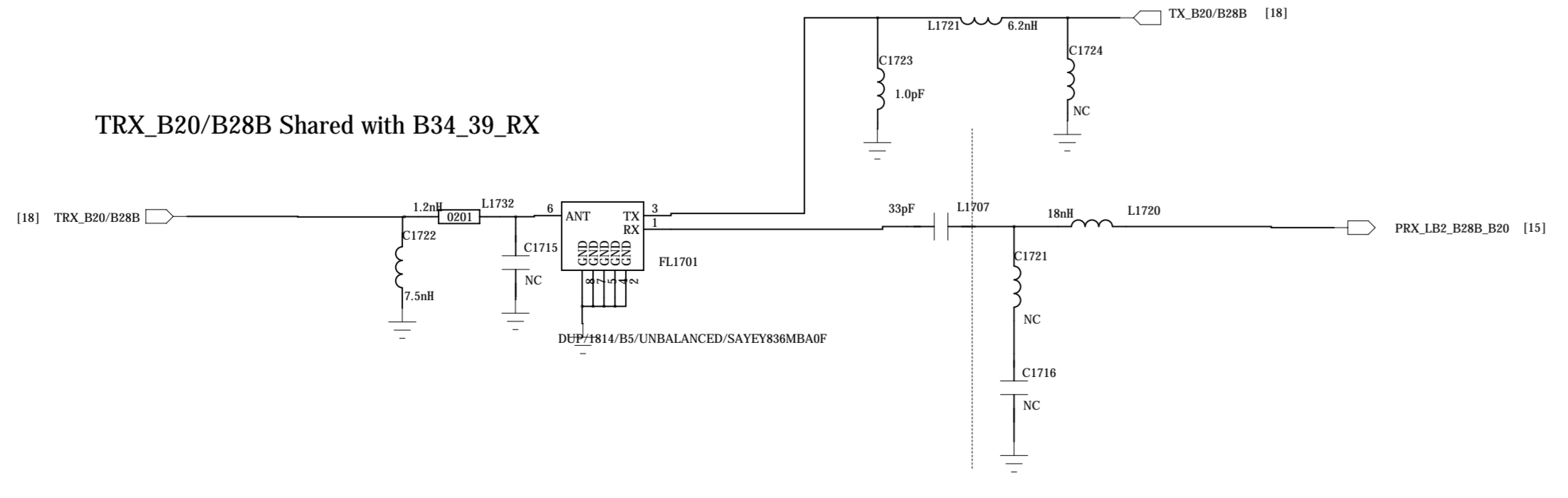

DRAWN: <Drawn By>		DATED: <Drawn Date>		COMPANY: <Company Name>	
CHECKED: <Checked By>		DATED: <Checked Date>		TITLE: <Title>	
QUALITY CONTROL: <QC By>		DATED: <QC Date>		CODE: <Code>	SIZE: A0
RELEASED: <Released By>		DATED: <Release Date>		DRAWING NO: <Drawing Number>	
		SCALE: <Scale>		REV: <Revision>	
				SHEET 10 21	

REVISION RECORD			
REV	ECO NO.	APPROVED	DATE

If walsin, R61, R62 should be NC

D

C

B

A

SAR Sensor

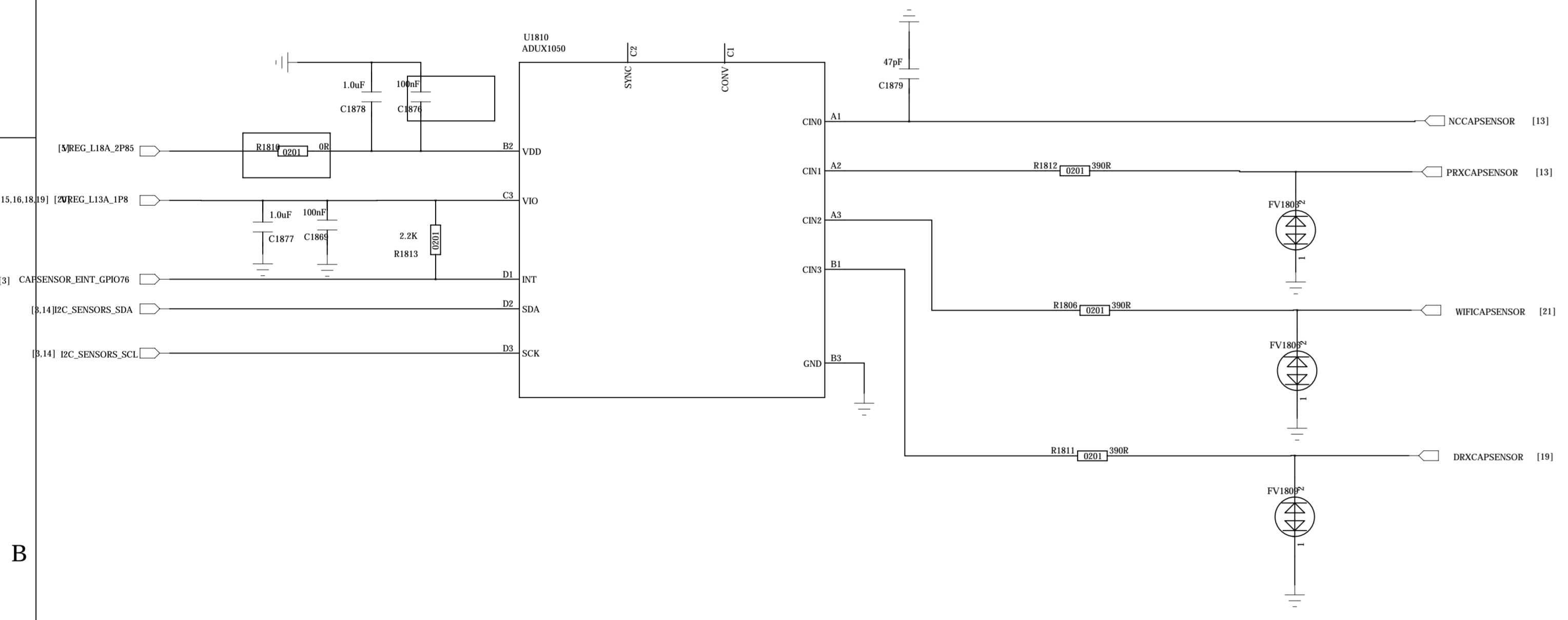

delete C1840

Add TVS!Ü

Changed this pin supplied by APT when SKY or VPH when Qorvo

IF no use LPF
IF use LPF $L1825=0R+C1836=3.9nH+L1821=1.2nH+SAW+NC+1.2nH+NC$

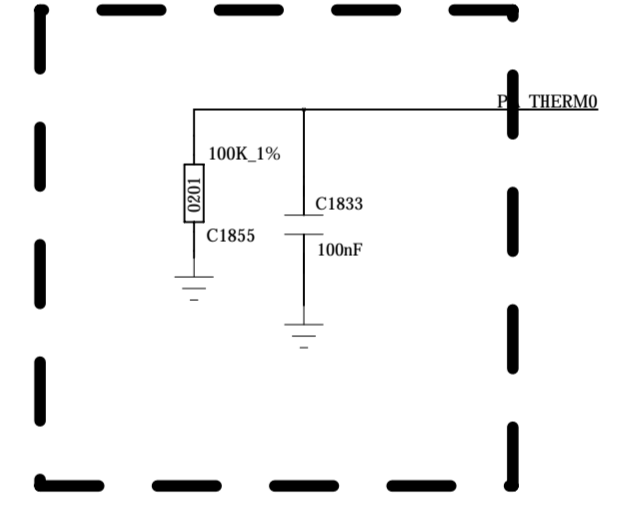
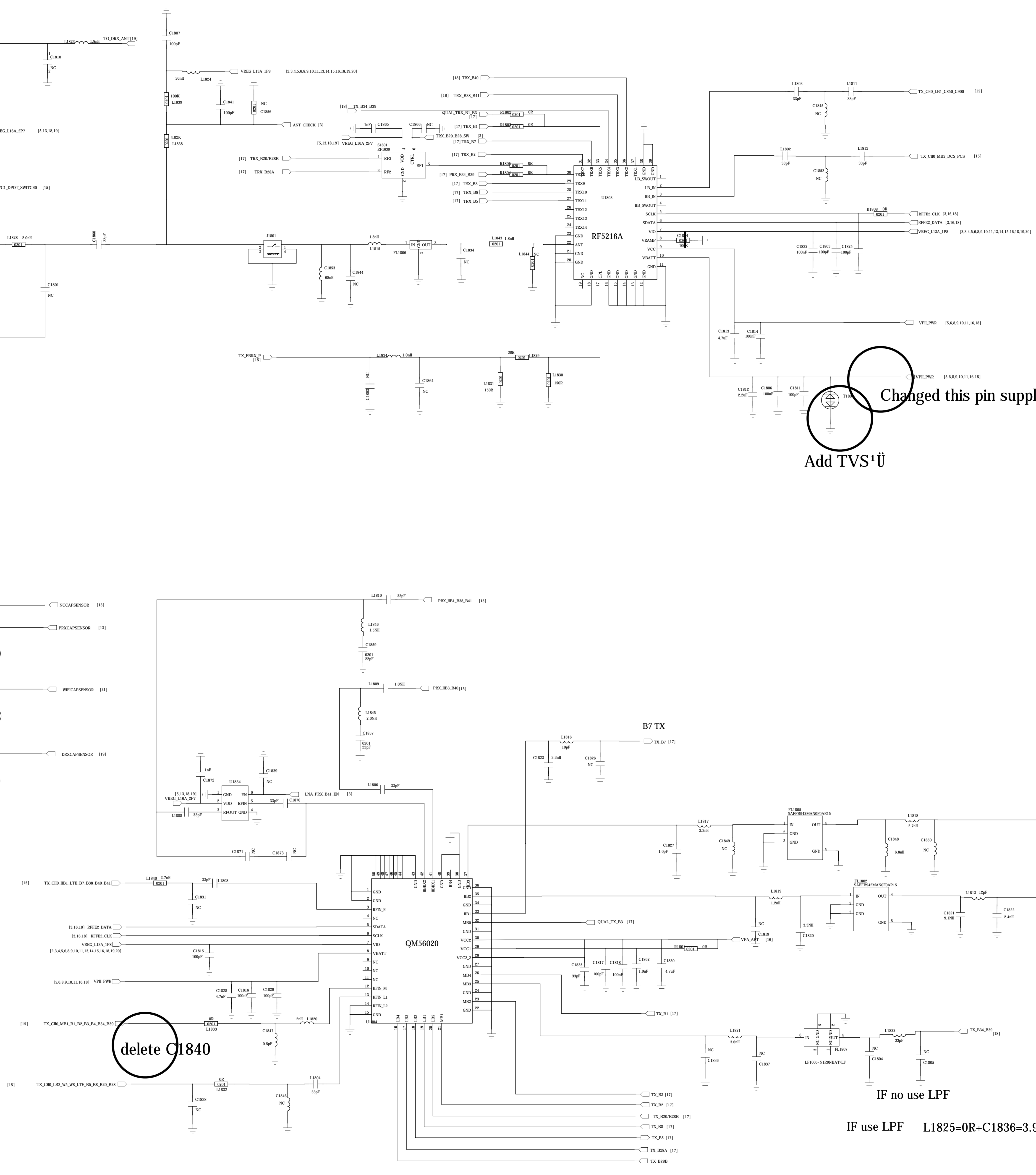

COMPANY: <Company Name>			
TITLE: <Title>			
DRAWN: <Drawn By>	DATE: <Drawn Date>		
CHECKED: <Checked By>	DATE: <Checked Date>	CODE: <Code>	REV: <Revision>
QUALITY CONTROL: <QC By>	DATE: <QC Date>	SIZE: A0	DRAWING NO: <Drawing Number>
RELEASED: <Released By>	DATE: <Release Date>	SCALE: <Scale>	SHEET: 18 / 21

REVISION RECORD			
LT#	REV NO.	APPROVED	DATE

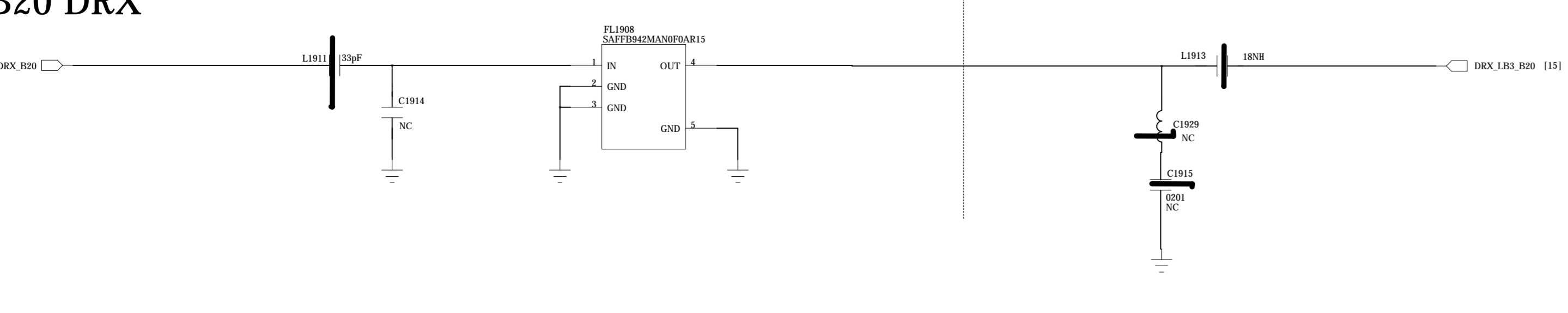
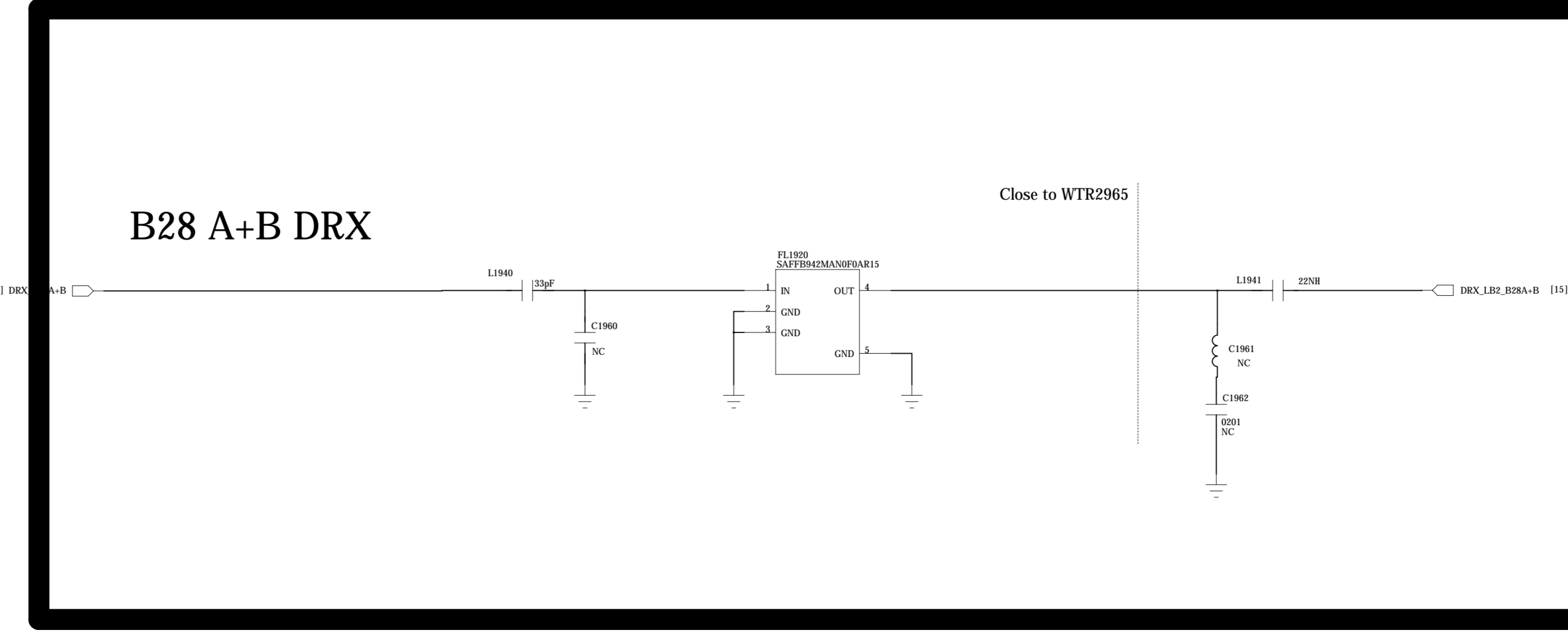
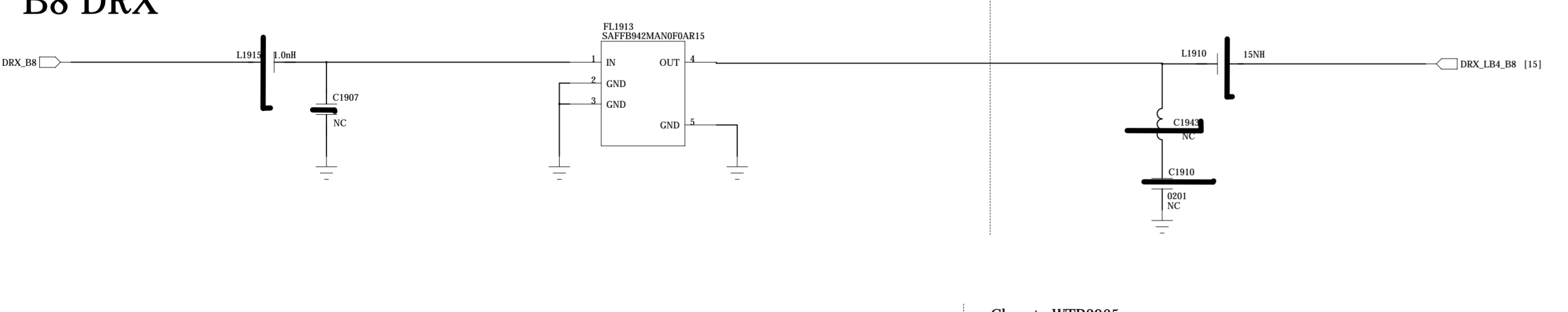
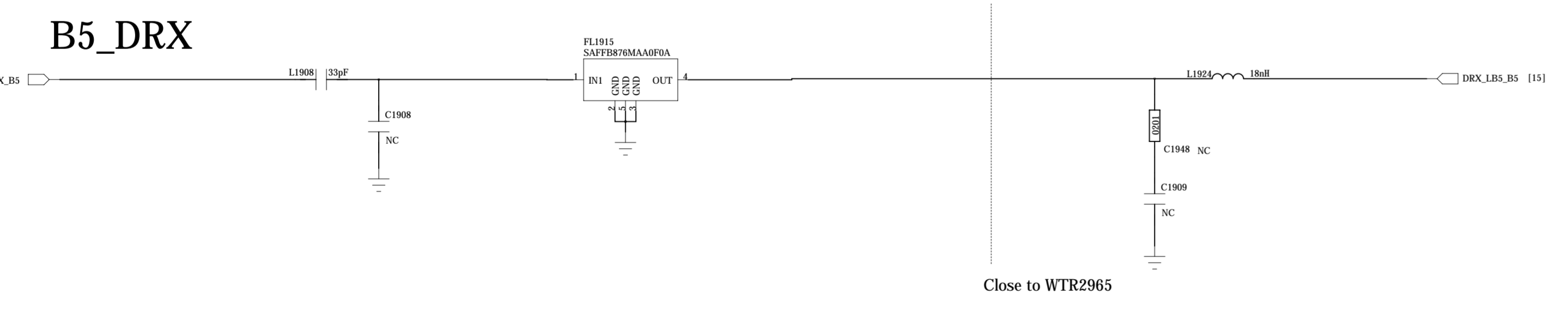
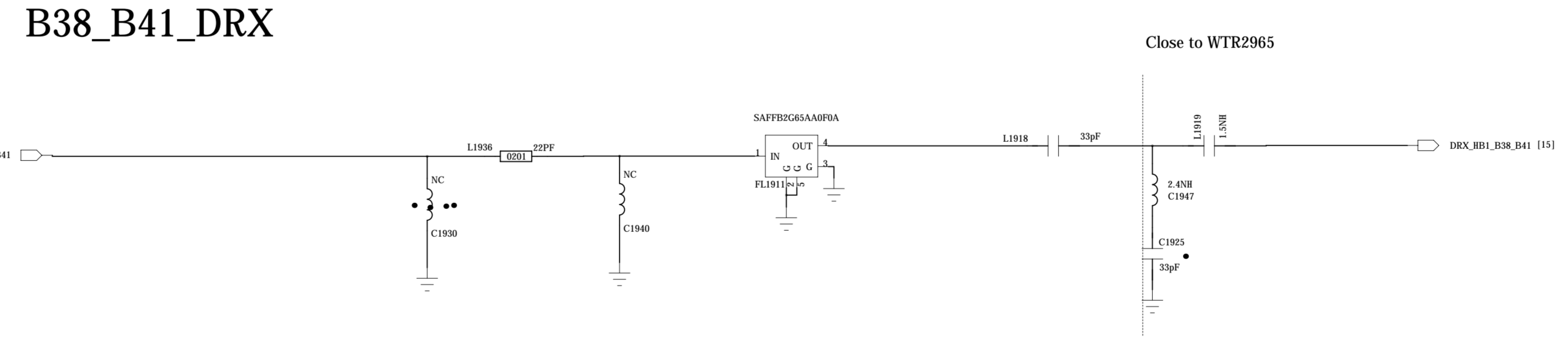
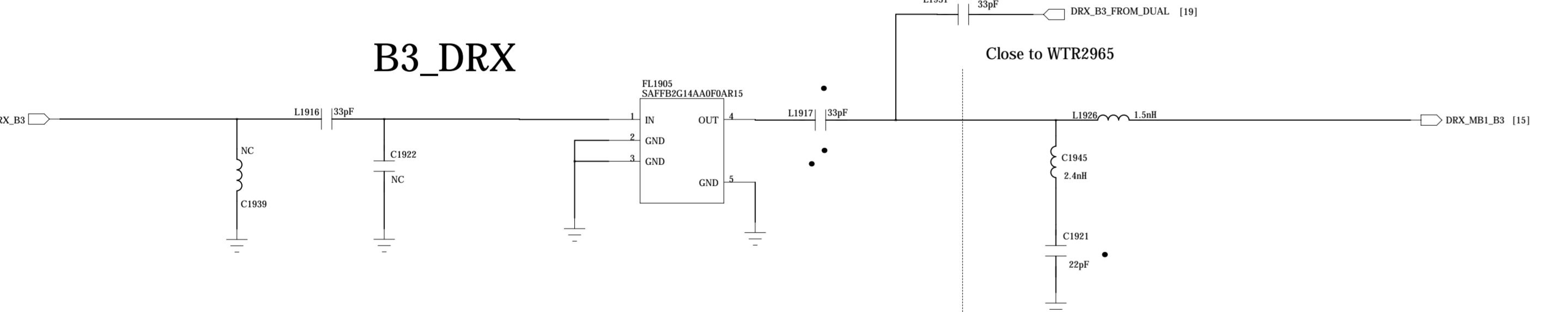
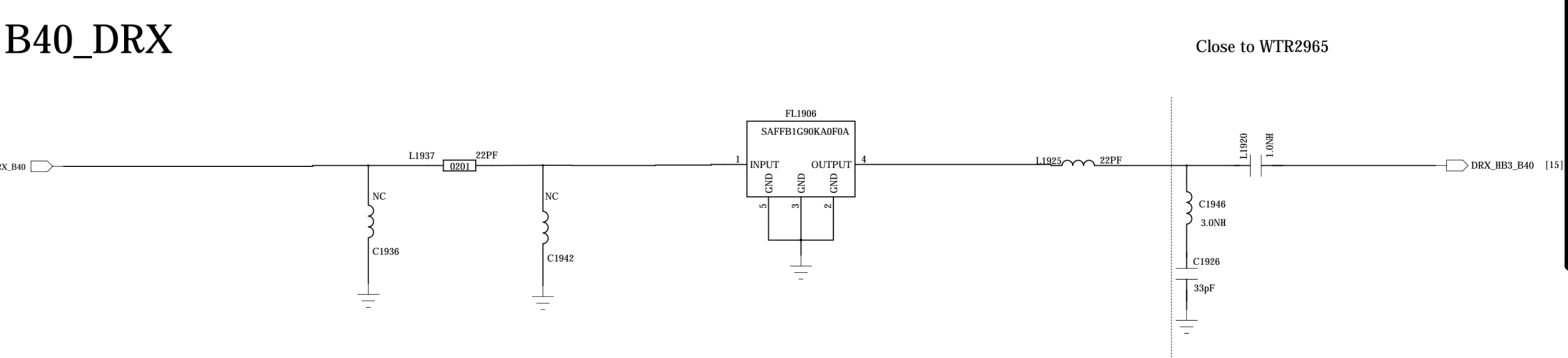
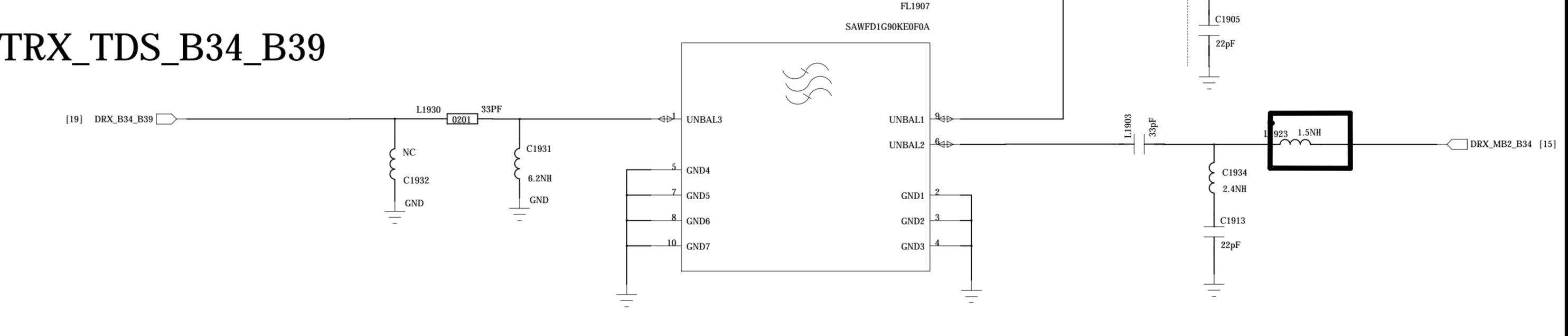
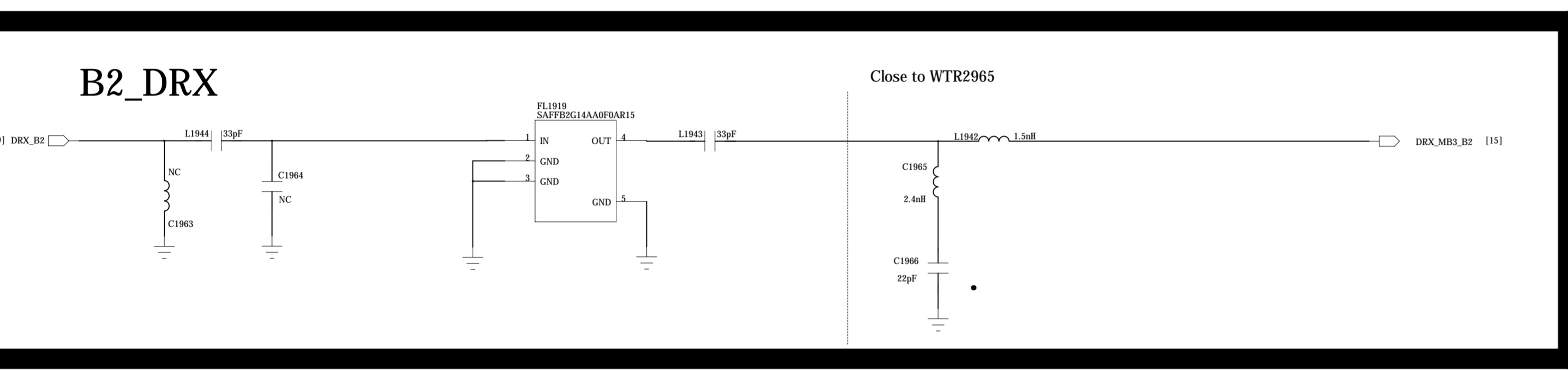
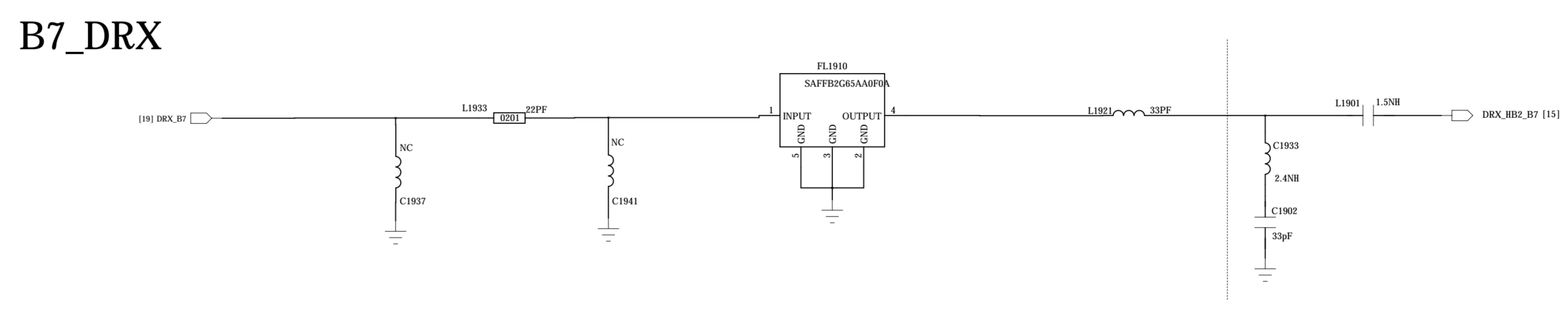
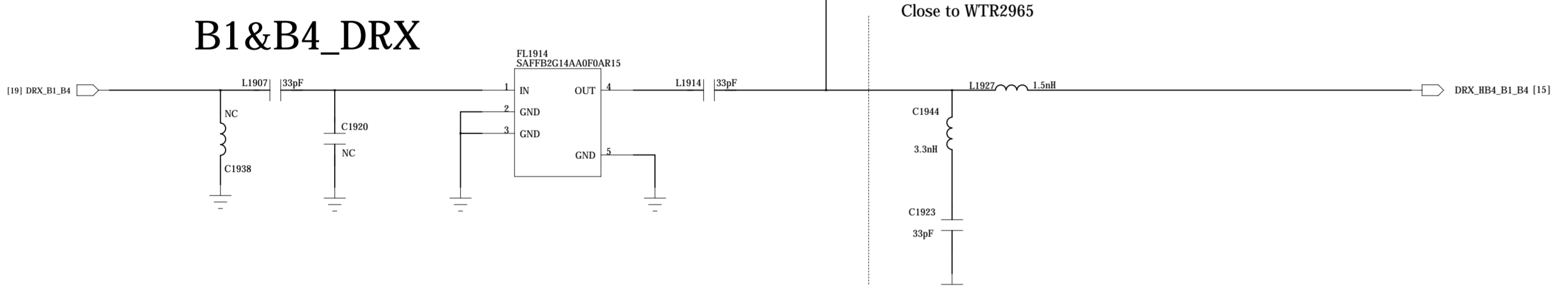
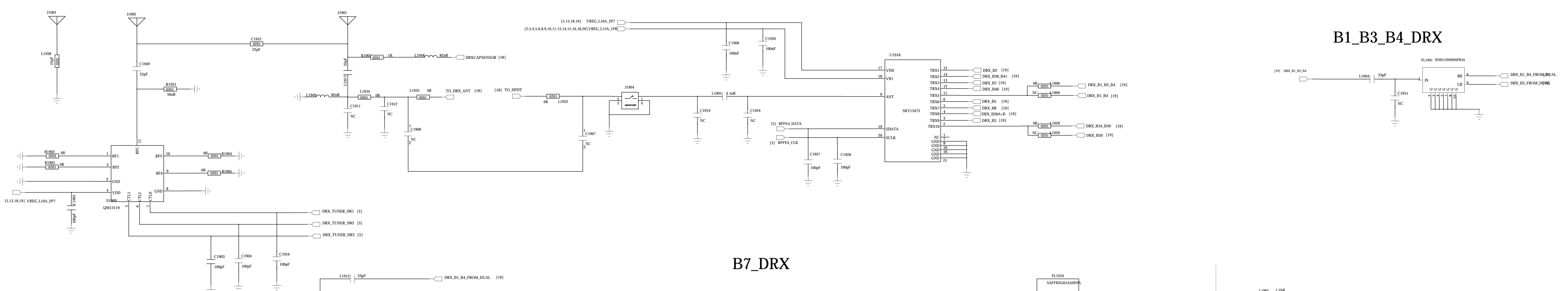

DRAWN: <Drawn By>		DATE: <Drawn Date>		COMPANY: <Company Name>	
CHECKED: <Checked By>		DATE: <Checked Date>		TITLE: <Title>	
QUALITY CONTROL: <QC By>		DATE: <QC Date>		CODE: <Code>	SIZE: A0
RELEASED: <Released By>		DATE: <Release Date>		DRAWING NO: <Drawing Number>	
SCALE: <Scale>		SHEET: 19		21	

